

IF IN DOUBT ASK!!

| G2840/1/2 SINGLE PAN FRYER - FITMENTS | | |
|---------------------------------------|------------|---|
| PART No. | SPARES No. | DESCRIPTION |
| 1A | 535770000 | OUTER FLUE PANEL - FOR WIRE HANGING RAIL - PRE DEC 2004 |
| 1B | 535870019 | FLUE ASSEMBLY - FOR TWO PIECE HANGING RAIL - PRE FEB 2006 - SUPPLY 1Z |
| 1C | 535770114 | FLUE ASSEMBLY - FOR ONE PIECE HANGING RAIL |
| 1Z | 535770117 | FLUE ASSEMBLY - 1C + 3C |
| 2 | 535770001 | FLUE HOLE PLUG |
| 3A | 535770002 | BASKET HANGING RAIL - WIRE - PRE DEC 2004 |
| 3B | 535770096 | BASKET HANGING RAIL - TWO PIECE - PRE FEB 2006 |
| 3C | 535770115 | BASKET HANGING RAIL - ONE PIECE |
| 4 | 535770003 | HOB & PAN ASSEMBLY |
| 5A | 535770004 | PAN LID - DISCONTINUED - NOW AS 5B |
| 5B | 535780000 | PAN LID |
| 6A | 535770005 | BASKET - LIPT MODELS ONLY |
| 6B | 535770089 | BASKET - STANDARD |
| 7 | 535770006 | FISH PLATE |
| 8 | 535770011 | DRAIN VALVE ASSEMBLY |
| 9 | 535770012 | DRAIN OUTLET PIPE |
| 10 | 535770013 | DRAIN HANDLE SPACER |
| 11 | 535770014 | DRAIN HANDLE C/W SLEEVE |
| 12 | 535770015 | DRAIN HANDLE SLEEVE |
| 13A | 535770048 | FLUE RISER - ONE PIECE - DISCONTINUED - NOW AS 13B |
| 13B | 535870015 | FLUE RISER - TWO PIECE |
| 14 | 535770049 | FLUE RISER GASKET |
| 15 | 535770088 | DRAIN PROD |
| 16 | 535770100 | HANGER SCREW |
| 17 | 535870020 | FLUE OUTER BACK |

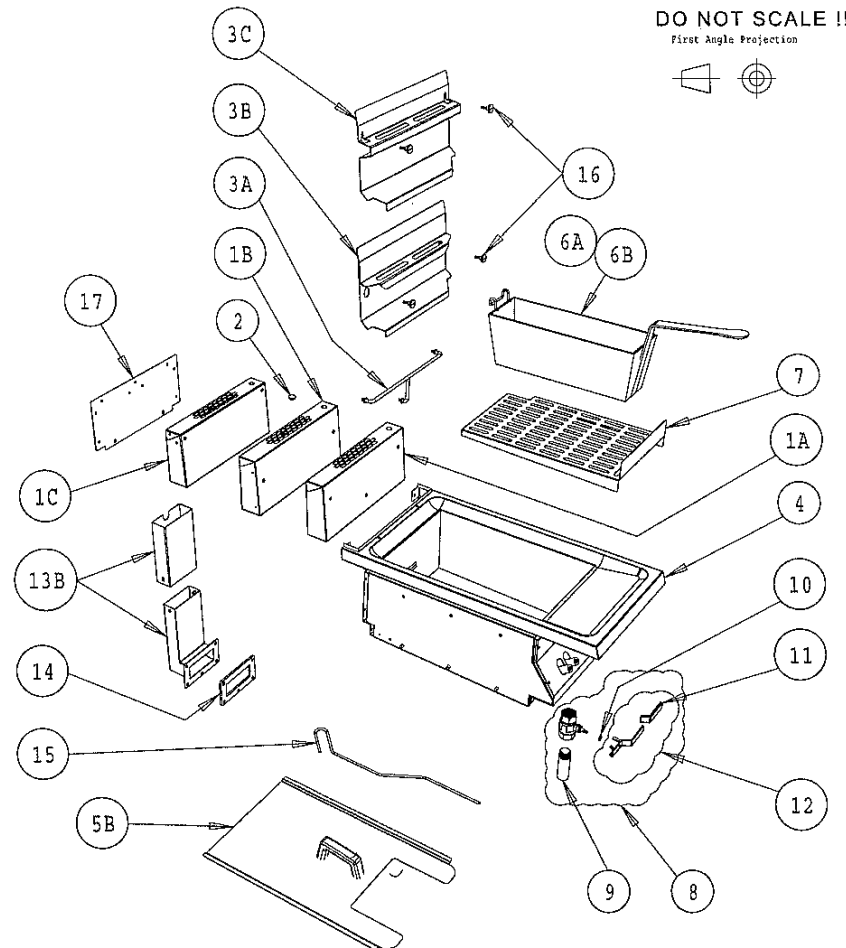

All Dimensions in millimetres, Tolerance- Linear $\pm 0.5mm$ Angular $\pm 0.5^\circ$ (or as stated)

| | | | | | | |
|---|--------|-------------------------|------------|----------|----------|------|
| C | | SPARES ISSUED - ISSUE C | | S. BROWN | 09/12/05 | |
| B | 5168 | BASKET MODIFIED | | G. SMITH | 26/07/04 | |
| A | 977/14 | PRODUCTION ISSUE | | G. SMITH | 18/02/04 | |
| G | Issue | Mod No. | Alteration | Zone | Drawn by | Date |



No reproduction or publication of this drawing may be made and no article may be manufactured or assembled in accordance with this drawing without prior written consent. The copyright is the property of any contract relating to this drawing. Rights reserved under the Copyright Act 1956 as amended by the Design Copyright Act 1988.

This part is common to the following units

UNCONTROLLED

| | | | | |
|---------|----------|----------------|----------------------------|-------|
| Drawn | G. SMITH | Product | G2840/1/2 SINGLE PAN FRYER | |
| Date | 18/02/04 | Title | SPARES - FITMENTS | |
| Scale | N. T. S. | Material | | |
| Bin No. | | Finish | | |
| | | Kraus No. | T111391 | |
| | | Drawing Number | AD42328 | Issue |
| | | | | C |

Falcon Foodservice Equipment. Wallace View Hillfoots Road Stirling Scotland

1 2 3 4 5 6 7 8

IF IN DOUBT ASK!!

DO NOT SCALE !!
First Angle Projection

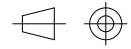

| G2840/1/2 SINGLE PAN FRYER - OIL CONTAINER COVER | | |
|--|------------|-------------------------------|
| PART No. | SPARES No. | DESCRIPTION |
| 1 | 535770022 | OIL CONTAINER COVER ASSEMBLY |
| 2 | 535770023 | DRAIN HANDLE LOCK |
| 3 | 535770024 | OIL COVER HOLE PLUG |
| 4 | 535770025 | IGNITER ACCESS COVER ASSEMBLY |

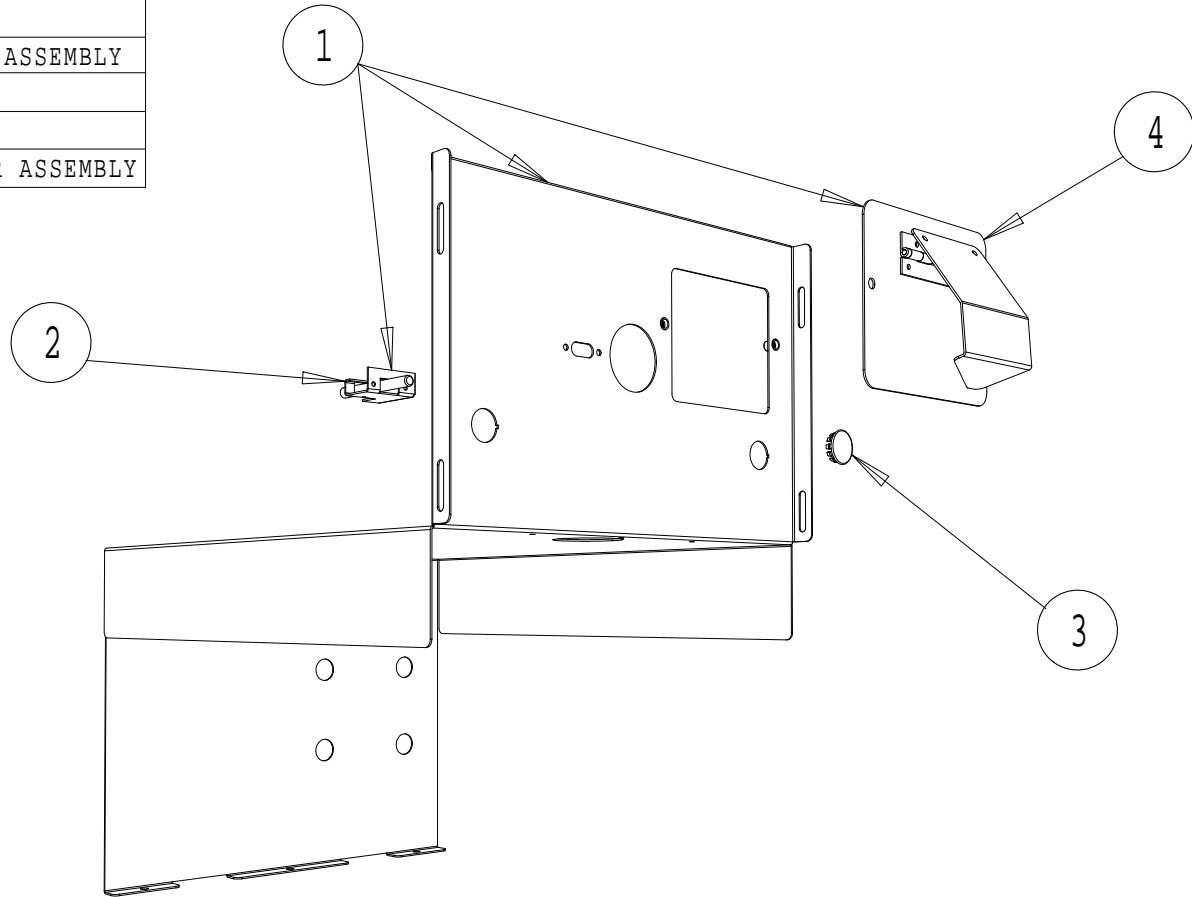

All Dimensions in millimetres, Tolerance- Linear $\pm 0.5\text{mm}$ Angular $\pm 0.5^\circ$ (or as stated)

| | | | | | | |
|---|--------|-------------------------|------------|----------|----------|------|
| | | | | | | |
| B | | SPARES ISSUED - ISSUE B | | S. BROWN | 07/12/05 | |
| A | 977/14 | PRODUCTION ISSUE | | G. SMITH | 17/02/04 | |
| G | Issue | Mod No. | Alteration | Zone | Drawn by | Date |

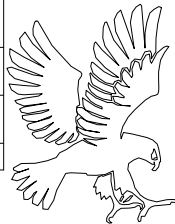

| | | | | |
|---------|----------|----------------|------------------------------|-------|
| Drawn | G. SMITH | Product | G2840/1/2 SINGLE PAN FRYER | |
| Date | 17/02/04 | Title | SPARES - OIL CONTAINER COVER | |
| Scale | N.T.S. | | | |
| Matl. | _____ | Drawing Number | | Issue |
| No. off | _____ | Finish | | |
| Bin No. | | Kraus No. | T111388 | |
| | | | AD42325 | B |

No reproduction or publication of this drawing may be made and no article may be manufactured or assembled in accordance with this drawing without prior written consent. This prohibition is a condition of any contract relating to this drawing. Rights reserved under the Copyright Act 1956 as amended by the Design Copyright Act 1988.

UNCONTROLLED

Falcon Foodservice Equipment. Wallace View Hillfoots Road Stirling Scotland

IF IN DOUBT ASK!!

DO NOT SCALE !!
First Angle Projection

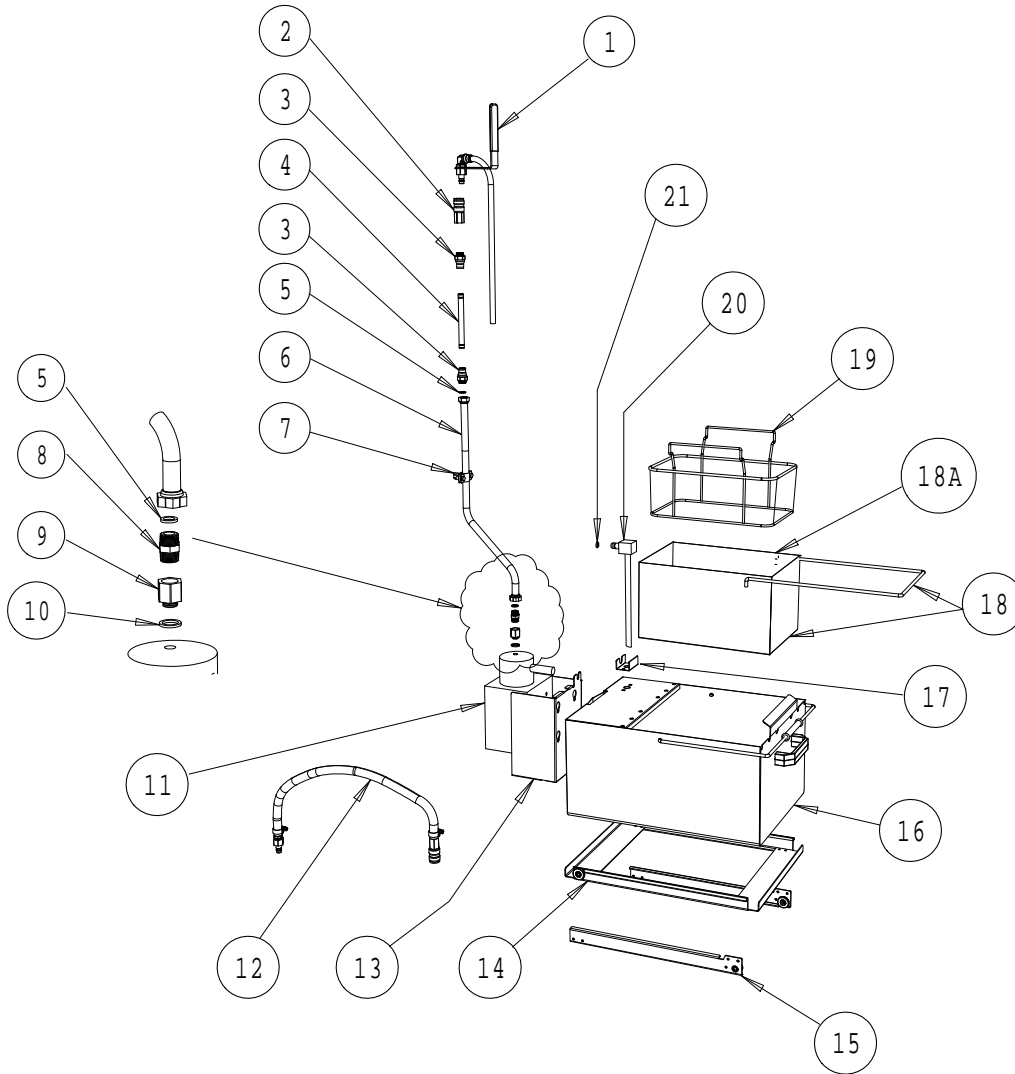

| No. | DESCRIPTION | SPARES No. |
|-----|---|------------|
| 01 | OIL DELIVERY HOSE | 535870010 |
| 02 | EXTERNAL QUICK RELEASE CONNECTION | 535770085 |
| 03 | INTERNAL QUICK RELEASE FITTING | 535770084 |
| 04 | STAINLESS STEEL RIDGID PIPE | 535770110 |
| 05 | COPPER WASHER \varnothing 15.0mm | 737401239 |
| 06 | STAINLESS STEEL FLEXIBLE PIPE C/W WASHERS | 535770111 |
| 07 | PIPE CLAMP | 535770112 |
| 08 | DOUBLE MALE NIPPLE 3/8" 8mm | 535770113 |
| 09 | INCREASER MALE TO FEMALE C/W 'O' RING | 737401233 |
| 10 | COPPER WASHER \varnothing 8.5mm | 737401245 |
| 11 | FILTRATION PUMP C/W SCREWS | 535770077 |
| 12 | RED EXTENSION HOSE | 535770087 |
| 13 | FILTRATION PUMP MOUNTING BRACKET | 535770074 |
| 14 | OIL RETENTION CRADLE | 535770028 |
| 15 | OIL RETENTION RUNNERS | 535770026 |
| 16 | OIL RETENTION BUCKET C/W SPLASHGUARD | 535770095 |
| 17 | OIL SUCTION PIPE BRACKET | 535770075 |
| 18 | MICRO FILTER ASSEMBLY | 535770030 |
| 18A | MICRO FILTER | 535770120 |
| 19 | STRAINER BASKET | 535770032 |
| 20 | OIL SUCTION PIPE | 535770076 |
| 21 | OIL SUCTION PIPE 'O'-RING | 739400997 |

All Dimensions in millimetres, Tolerance- Linear ± 0.5 mm Angular $\pm 0.5^\circ$ (or as stated)

| | | | | | |
|----------------------------------|-------|---------|---------------------------|----------|----------|
| Drawing Number BD42331 | | | | | |
| | C | | SPARES ISSUED - ISSUE C | S. BROWN | 12/12/05 |
| | B | 5162 | OIL RETURN SYSTEM AMENDED | G. SMITH | 07/07/04 |
| | A | 977/14 | PRODUCTION ISSUE | G. SMITH | 10/12/04 |
| | Issue | Mod No. | Alteration | Zone | Drawn by |

No reproduction or publication of this drawing may be made and no article may be manufactured or assembled in accordance with this drawing without prior written consent. This prohibition is a term of any contract relating to this drawing. Rights reserved under the Copyright Act 1956 as amended by the Design Copyright Act 1988.

This part is common to the following units

UNCONTROLLED



| | | | | |
|---------|----------|----------------|----------------------------|-------|
| Drawn | G. SMITH | Product | G2840/1/2 SINGLE PAN FRYER | |
| Date | 18/02/04 | Title | SPARES - OIL FILTRATION | |
| Scale | N.T.S. | Drawing Number | BD42331 | Issue |
| Matl. | _____ | | | C |
| No. off | _____ | Finish | _____ | |
| Bin No. | _____ | Kraus No. | T111393 | |

IF IN DOUBT ASK!!

DO NOT SCALE !!

First Angle Projection



| G2840/1/2 SINGLE PAN FRYER - OUTER PANELS | | |
|---|------------|---|
| Part No. | Spares No. | Description |
| 1 | 535770010 | FALCON BADGE |
| 2 | 535770016 | DOOR HINGE |
| 3 | 535770017 | DOOR ASSEMBLY |
| 4 | 535770018 | RH OUTER SIDE PANEL |
| 5 | 535770019 | LH OUTER SIDE PANEL |
| 6 | 535770020 | ADJUSTABLE FOOT (1 OFF) |
| 7 | 535770021 | CASTOR (1 OFF) |
| 8 | 535770045 | REMOVABLE OUTER BACK (NO BASKET LIFT) |
| 9 | 535770046 | GAS INLET PIPE ASSEMBLY |
| 10 | 535770047 | PRESSURE TEST NIPPLE |
| 11 | 535780001 | REMOVABLE OUTER BACK (WITH BASKET LIFT) |

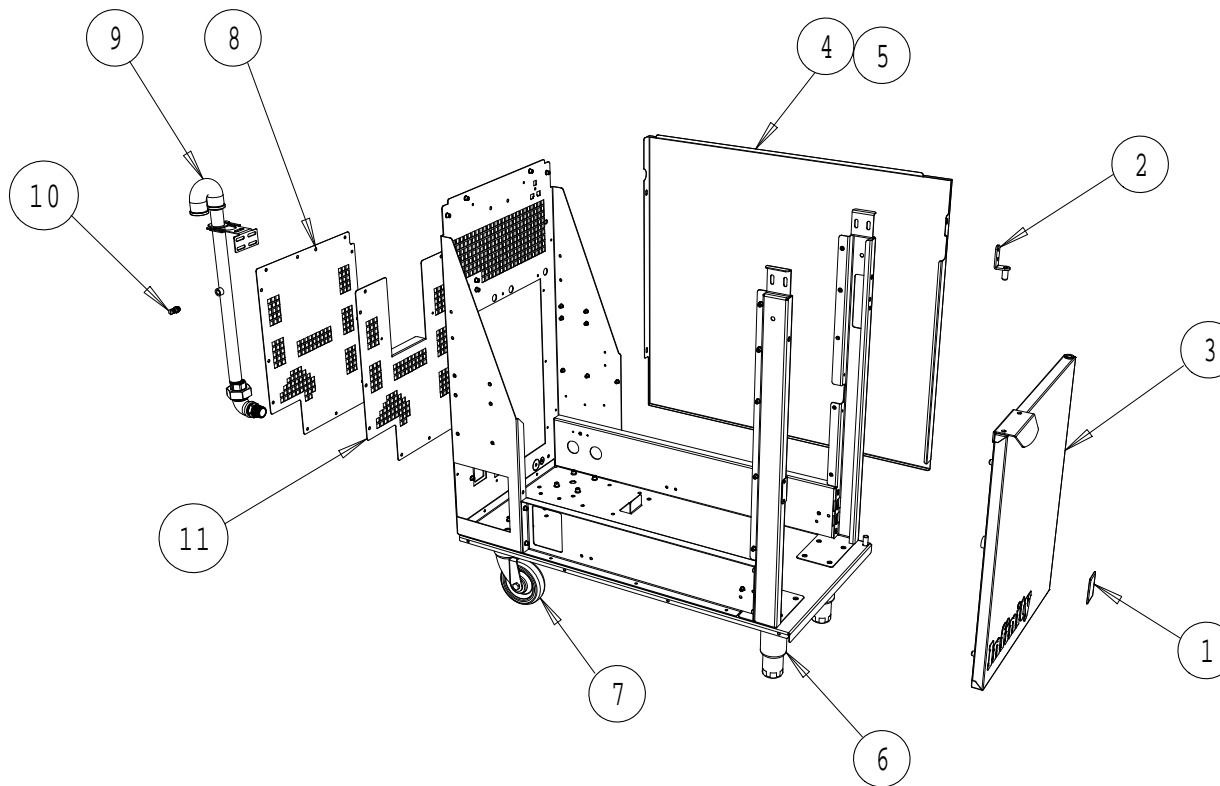

All Dimensions in millimetres, Tolerance- Linear $\pm 0.5\text{mm}$ Angular $\pm 0.5^\circ$ (or as stated)

| | | | | | | |
|----------------|--|------------|------------------------|----------|-------------------|--|
| Drawing Number | BD42329 | | | | | |
| | <p style="text-align: center;">No reproduction or publication of this drawing may be made and no article may be manufactured or assembled in accordance with this drawing without prior written consent. This prohibition is a term of any contract relating to this drawing. Rights reserved under the Copyright Act 1956 as amended by the Design Copyright Act 1988.</p> <p style="text-align: center;">This part is common to the following units</p> <p style="text-align: center;">-----</p> | | | | | |
| | B | | SPARES ISSUE - ISSUE B | | G. BROWN 12/12/05 | |
| | A | | PRODUCTION ISSUE | | G. SMITH 18/02/04 | |
| Issue | Mod No. | Alteration | Zone | Drawn by | Date | |

©



| | | | | | | |
|---------|----------|----------------|----------------------------|--|-------|---|
| Drawn | G. SMITH | Product | G2840/1/2 SINGLE PAN FRYER | | | |
| Date | 18/02/04 | Title | SPARES - OUTER PANELS | | | |
| Scale | N.T.S. | Drawing Number | BD42329 | | Issue | B |
| Matl. | | Kraus No. | T111392 | | | |
| No. off | | | | | | |
| Bin No. | | | | | | |

UNCONTROLLED

IF IN DOUBT ASK!!

DO NOT SCALE !!

First Angle Projection

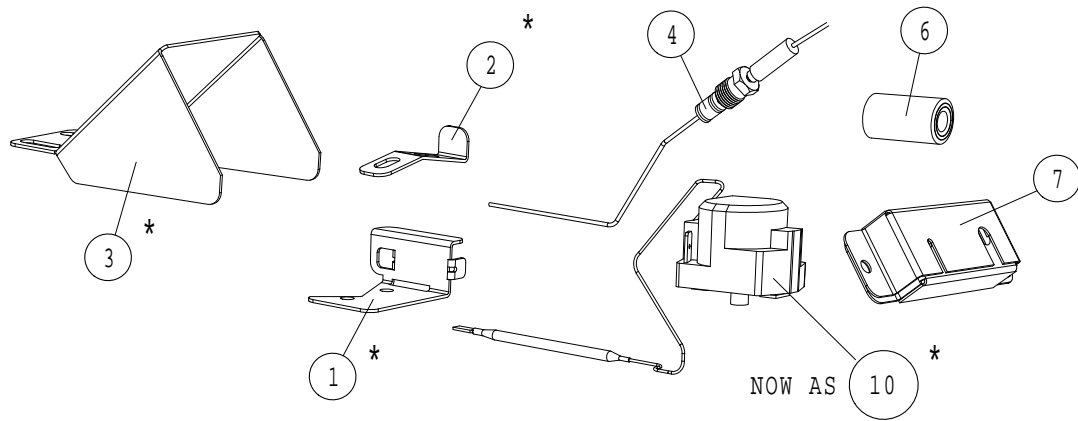
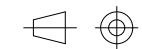

PRE - SEPTEMBER 2004

G2840/1/2 SINGLE PAN FRYER - CONTROLS

| Part No. | Spares No. | Description |
|----------|------------|--------------------------------|
| 1 | 535770007 | Phial Guard Mounting Bracket* |
| 2 | 535770008 | Phial Guard Retaining Bracket* |
| 3 | 535770009 | Phial Guard* |
| 4 | 535770069 | Thermocouple |
| 5 | ————— | Discontinued |
| 6 | 535770071 | Ferrite Bead |
| 7 | 535770072 | Boss Insulation Assembly |
| 8 | 535770098 | Phial Guard |
| 9 | 535770099 | Phial Clamp Plate |
| 10 | 535770070 | Safety Limit Device |

POST- SEPTEMBER 2004

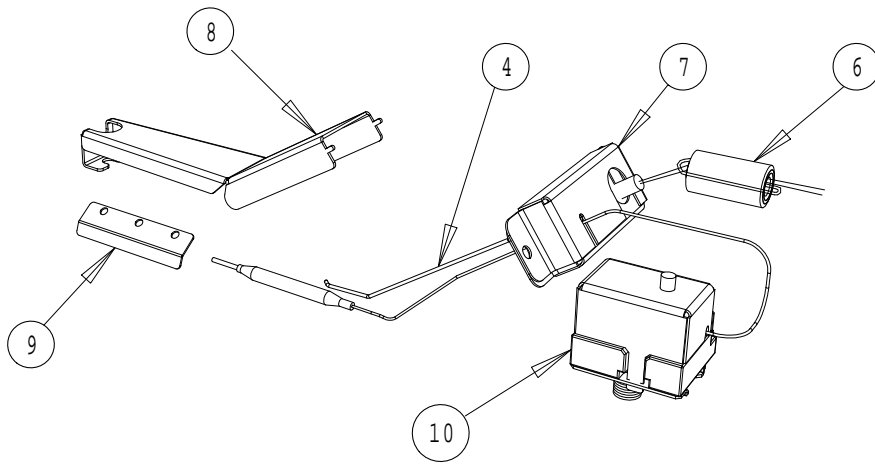

* PRE - SEPTEMBER 2004

All Dimensions in millimetres, Tolerance- Linear ±0.5mm Angular ±0.5° (or as stated)

| | | | | | | |
|---|--------|-------------------------|------------|----------|----------|------|
| B | | SPARES ISSUED - ISSUE B | | S. BROWN | 07/12/05 | |
| A | 977/14 | PRODUCTION ISSUE | | G. SMITH | 17/02/04 | |
| G | Issue | Mod No. | Alteration | Zone | Drawn by | Date |



This part is common to the following units

© No reproduction or publication of this drawing may be made and no article may be manufactured or assembled in accordance with this drawing without prior written consent. This prohibition is a condition of any contract relating to this drawing. Rights reserved under the Copyright Act 1956 as amended by the Design Copyright Act 1988.

UNCONTROLLED

| | | | | |
|---------|----------|----------------|----------------------------|-------|
| Drawn | G. SMITH | Product | G2840/1/2 SINGLE PAN FRYER | |
| Date | 17/02/04 | Title | SPARES - CONTROLS | |
| Scale | N.T.S. | | | |
| Matl. | ————— | Drawing Number | AD42326 | Issue |
| No. off | ————— | Finish | | B |
| Bin No. | ————— | Kraus No. | T111389 | |

IF IN DOUBT ASK!!

DO NOT SCALE !!

First Angle Projection

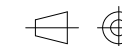

* PRE - JUNE 2005

| G2840/1/2 SINGLE PAN FRYER - ELECTRICS | | |
|--|------------|-------------------------------------|
| Part No. | Spares No. | Description |
| 1 | 535770061 | MAINS CABLE C/E PLUG |
| 2 | 535770062 | MAINS CABLE CORD GRIP |
| 3 | 535770063 | SOFT START MOUNTING PLATE |
| 4 | 535770064 | STAND OFF (1 OFF) |
| 5 | 535770065 | REAR ELECTRICS COVER PLATE |
| 6 | 535770066 | MAINS TERMINAL BLOCK |
| 7 | 535770067 | RELAY * |
| 8 | 535770068 | MOMENTARY SWITCH (1 OFF) |
| 9 | 535770107 | EBM FAN SPEED CONTROLLER PCB |
| 10 | 535770044 | HONEYWELL SOFT START BOARD PCB 230V |
| 11 | 535770116 | TRANSFORMER 230V TO 24V |
| 12 | 535870005 | HONEYWELL SOFT START BOARD PCB 24V |
| 13 | 535870022 | SOFT START TO EBM CONVERSION KIT |

NOW AS 13

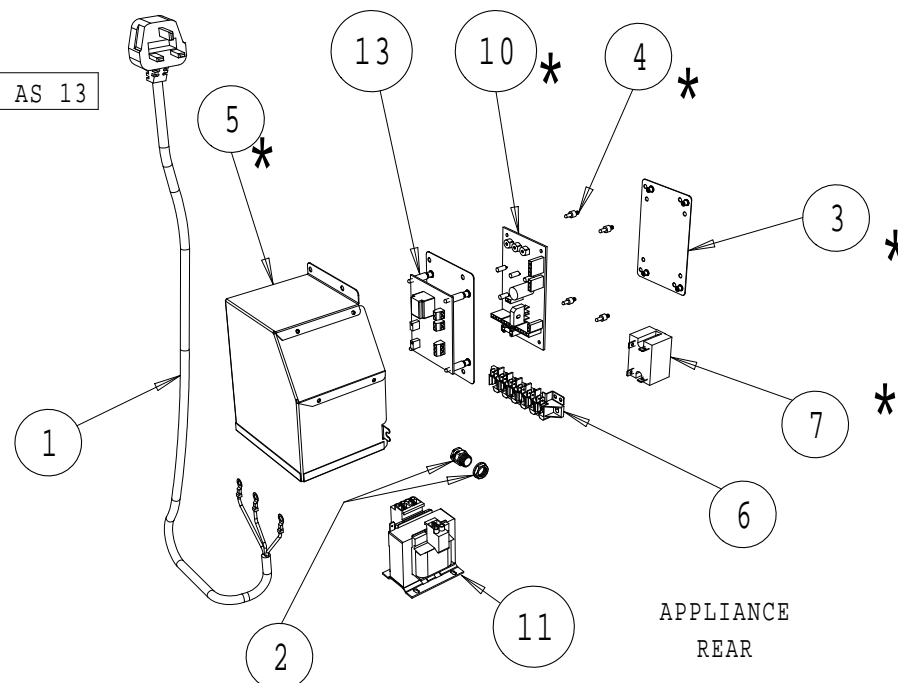
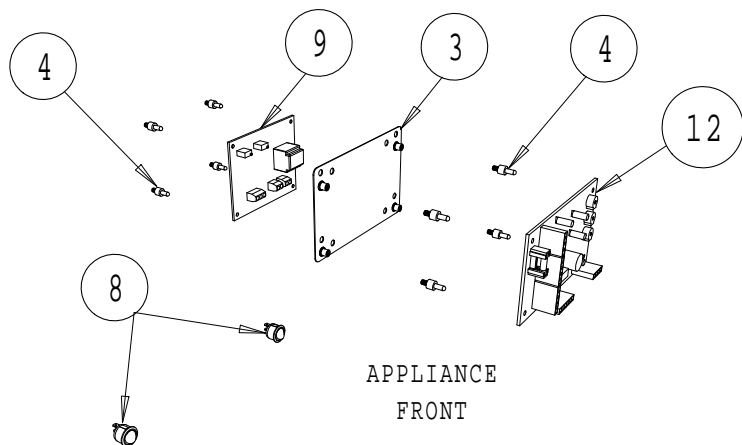

All Dimensions in millimetres, Tolerance- Linear ±0.5mm Angular ±0.5° (or as stated)

| | | | | | | |
|---|--------|-------------------------|------------|----------|----------|------|
| B | | SPARES ISSUED - ISSUE B | | S. BROWN | 09/12/05 | |
| A | 977/14 | PRODUCTION ISSUE | | G. SMITH | 17/02/04 | |
| G | Issue | Mod No. | Alteration | Zone | Drawn by | Date |



| | | | | |
|---------|----------|-----------|----------------------------|----------------|
| Drawn | G. SMITH | Product | G2840/1/2 SINGLE PAN FRYER | |
| Date | 17/02/04 | Title | SPARES - ELECTRICS | |
| Scale | N.T.S. | Matl. | _____ | Drawing Number |
| No. off | _____ | Finish | _____ | Issue |
| Bin No. | _____ | Kraus No. | T111390 | AD42327 |
| | | | | B |

© No reproduction or publication of this drawing may be made and no article may be manufactured or assembled in accordance with this drawing without prior written consent. This prohibition is a condition of any contract relating to this drawing. Rights reserved under the Copyright Act 1956 as amended by the Design Copyright Act 1988.

This part is common to the following units

UNCONTROLLED

Falcon Foodservice Equipment. Wallace View Hillfoots Road Stirling Scotland

IF IN DOUBT ASK!!

DO NOT SCALE !!
First Angle Projection

G2841/2 SINGLE PAN FRYER - BASKET LIFT

| Part No. | Spares No. | Description |
|----------|------------|-------------------|
| 1 | 535780008 | Basket Lift Motor |
| 2 | 535780009 | Basket Lift |
| 3 | 535780011 | Basket Lift Cover |
| 4 | 535780013 | Basket Lift Guide |

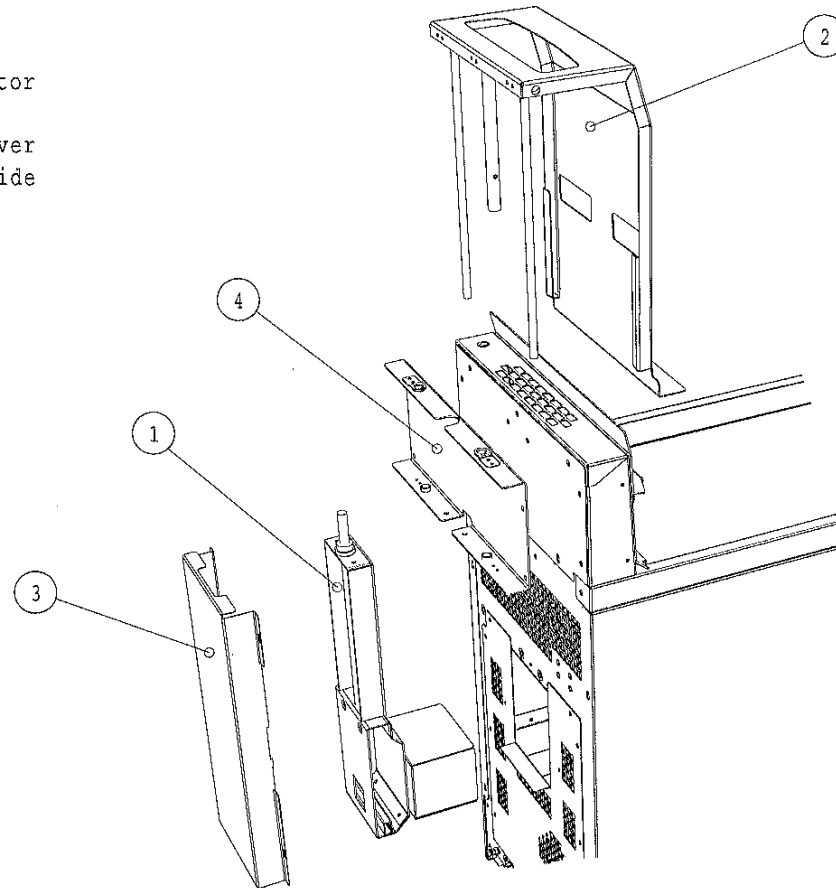

All Dimensions in millimetres, Tolerance- Linear $\pm 0.5\text{mm}$ Angular $\pm 0.5^\circ$ (or as stated)

| Issue | Mod No. | Alteration | Zone | Drawn by | Date |
|-------|---------|-------------------------------------|------|----------|----------|
| B | 5370 | REDESIGNED BASKET LIFT REPLACES OLD | | DJT | 13/05/05 |
| A | 977/14 | PRODUCTION ISSUE | | G. SMITH | 18/02/04 |



| | | | | |
|---------|----------|----------------|--------------------------|-------|
| Drawn | G. SMITH | Product | G2841/2 SINGLE PAN FRYER | |
| Date | 18/02/04 | Title | SPARES - BASKET LIFT | |
| Scale | N. T. S. | Drawing Number | AD42332 | Issue |
| Bin No. | | Kraus No. | T111395 | B |

© No reproduction or publication of this drawing may be made and no article may be manufactured or assembled in accordance with this drawing without prior written consent. The copyright in this drawing is reserved for the copyright owner. All rights reserved. The Copyright Act 1988 as amended by the Design Copyright Act 2001.

This part is common to the following units

UNCONTROLLED

Falcon Foodservice Equipment. Wallace View Hillfoots Road Stirling Scotland

IF IN DOUBT ASK!!

DO NOT SCALE !!

First Angle Projection

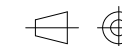

| G2842 SINGLE PAN FRYER - CONTROL PANEL | | |
|--|------------|-------------------------|
| PART No. | SPARES No. | DESCRIPTION |
| 1 | 535790000 | CONTROL PANEL ASSEMBLY |
| 2 | 535770054 | CIRCULAR SPACER (1 Off) |
| 3 | 535790001 | DISPLAY BOARD FFM |
| 4 | 535770064 | STAND OFF (1 Off) |
| 5 | 535780004 | CONTROL BOARD PCB |
| 6 | 535780003 | INTERFACE BOARD |

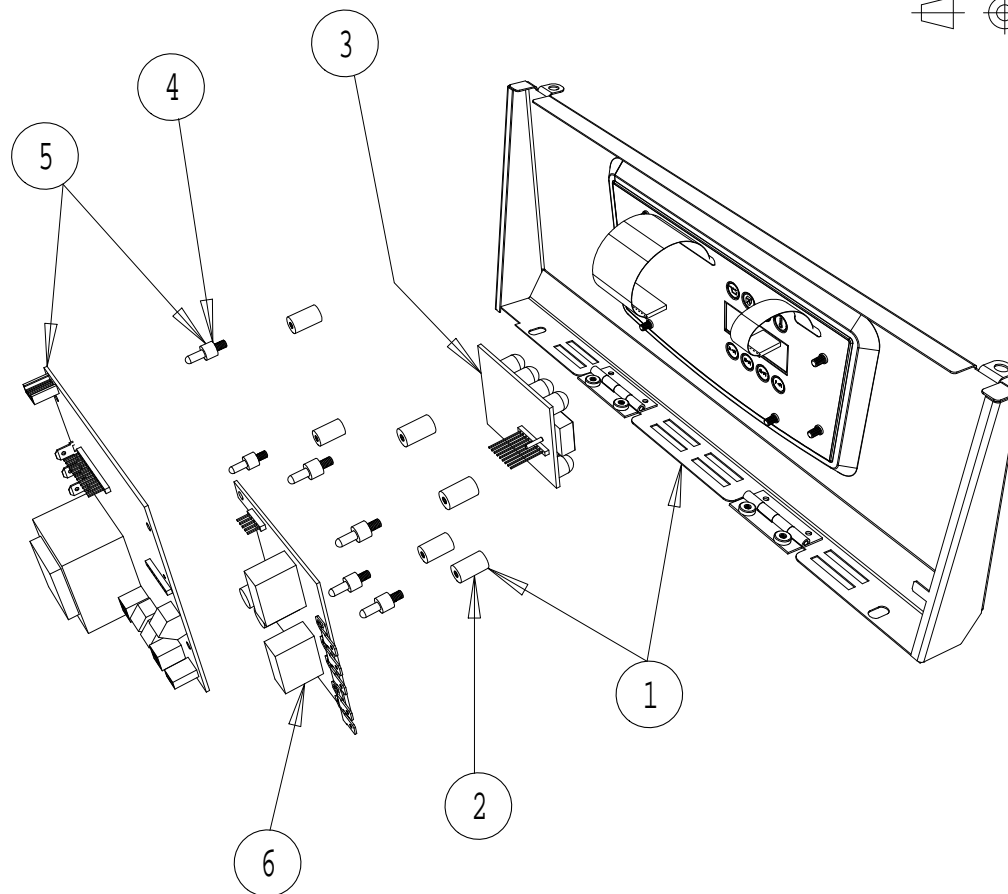

All Dimensions in millimetres, Tolerance- Linear $\pm 0.5\text{mm}$ Angular $\pm 0.5^\circ$ (or as stated)

| | | | | | |
|---|--------|-------------------------|------------|----------|----------|
| | | | | | |
| B | | SPARES ISSUED - ISSUE B | | S. BROWN | 07/12/05 |
| A | 977/14 | PRODUCTION ISSUE | | G. SMITH | 16/02/04 |
| G | Issue | Mod No. | Alteration | Zone | Drawn by |
| | | | | | Date |



| | | | | |
|---------|----------|----------------|------------------------|-------|
| Drawn | G. SMITH | Product | G2842 SINGLE PAN FRYER | |
| Date | 16/02/04 | Title | SPARES - CONTROL PANEL | |
| Scale | N.T.S. | | | |
| Matl. | _____ | Drawing Number | | Issue |
| No. off | _____ | Finish | | |
| Bin No. | _____ | Kraus No. | T111387 | |
| | | | AD42322 | B |

No reproduction or publication of this drawing may be made and no article may be manufactured or assembled in accordance with this drawing without prior written consent. This prohibition is a condition of any contract relating to this drawing. Rights reserved under the Copyright Act 1956 as amended by the Design Copyright Act 1988.

This part is common to the following units

UNCONTROLLED

Falcon Foodservice Equipment. Wallace View Hillfoots Road Stirling Scotland