

N.B.: La tavola si completa con la successiva n° See table No. Voir tableau n° Wichtig: S. folgender Plan Nr.

→ 3E01-003 K4FSFCE	→ 3E01-012 K4ZFCE - K6ZFCE K8ZFCE - K4ZSFCE	→ 3E01-014 KTPFCE K2FTPFCE	→ 3E01-015 K4PFCE K6PFCE	→ 3E01-016 K4VFCE
-----------------------	---	----------------------------------	--------------------------------	----------------------

## 3E01-007

K4ZFCE - K4ZSFCE - K4FSFCE  
KTPFCE - K2FTPFCE - K4PFCE  
K4VFCE - K6ZFCE - K6PFCE  
K8ZFCE



Pezzi/Pieces Pieces/Anzahl										Pos.	Validità dalla matricola Validité du numéro matricule Validity from serial number Gültigkeit ab der (Seriennummer)	Validità alla matricola Validity up to serial number Validité au numéro matricule Gültigkeit bis zur (Seriennummer)	Codice Code Artikel Nummer	Descrizione	Description	Description	Beschreibung
K4FSFCE	K4FZFC	KTPFCE	K4PFCE	K4VFC	K4ZSFCE	K6FZFC	K2FTPFCE	K6PFCE	K8FZFC								
1	1	1	1	1	1	1	1	1	1	2	1		X50900	Lampada verde	Green light	Lampe vert	Grüne Kontrollampe
1	1	1	1	1	1	1	1	1	1	2	2		X68204	Commutatore	Selector switch	Commutateur	Schalter
1	1	1	1	1	1	1	1	1	1	2	3		0000X65008	Manopola commutatore	Selector knob	Bouton commutat.	Umschaltknopf
1	1	1	1	1	1	1	1	1	1	2	4		0000X65004	Manopola termostato	Knob thermostat	Cle de commande thermoc.	Drehknop thermostat
1	1	1	1	1	1	1	1	1	1	2	5		1000X05600	Guarnizione porta	Door seal	Joint porte	Türdichtung
1	1	1	1	1	1	1	1	1	1	2	6		X68205	Termostato	Oven thermostat	Thermostat	Thermostat
1	1	1	1	1	1	1	1	1	1	2	7		X41200	Lampada gialla	Yellow light	Lampe jaune	Gelbe kontrollampe
2	2	2	2	2	2	2	2	2	2	4	8		V05900	Reggigriglia sx/dx	R.H. grid support	Appui grille gauche	Oberer heizwiderstand
1	1	1	1	1	1	1	1	1	1	2	9		X66100	Cerniera sx	L.H. hinge	Charniere gauche	Rostauflageschiene L.
1	1	1	1	1	1	1	1	1	1	2	10		X68203	Resistenza inferiore	Bottom resistance	Resistance inferieure	Unterer heizwiderstand
1	1	1	1	1	1	1	1	1	1	2	11		G11PF	Griglia	Grid	Grille	Rost
1	1	1	1	1	1	1	1	1	1	2	12		X66000	Cerniera dx	R.H. hinge	Charniere droite	Scharnier rechts
1	1	1	1	1	1	1	1	1	1	2	13		X68202	Resistenza superiore	Top resistance	Resistance superieure	Oberer heizwiderstand
1	1	1	1	1	1	1	1	1	1	2	14		V03000	Motoventilatore	Electric fan	Moto-ventilateur	Motorventilator
1	1	1	1	1	1	1	1	1	1	2	15		V05400	Isolamento	Insulation	Isolation	Isolierung
1	1	1	1	1	1	1	1	1	1	2	16		Y65700	Maniglia forno	Oven handle	Poignée four	Backofengriff
1	1	1	1	1	1	1	1	1	1	2	17		X68002	Resistenza	Resistance	Resistance	Resistenz
1	1	1	1	1	1	1	1	1	1	2	18		X59000	Morsettiera	Terminal board	Barrette de raccordement	Klemmleiste
4	4	4	4	4	4	4	4	4	4	4	19		Y40400	Piedino	Foot	Pied	Fuss

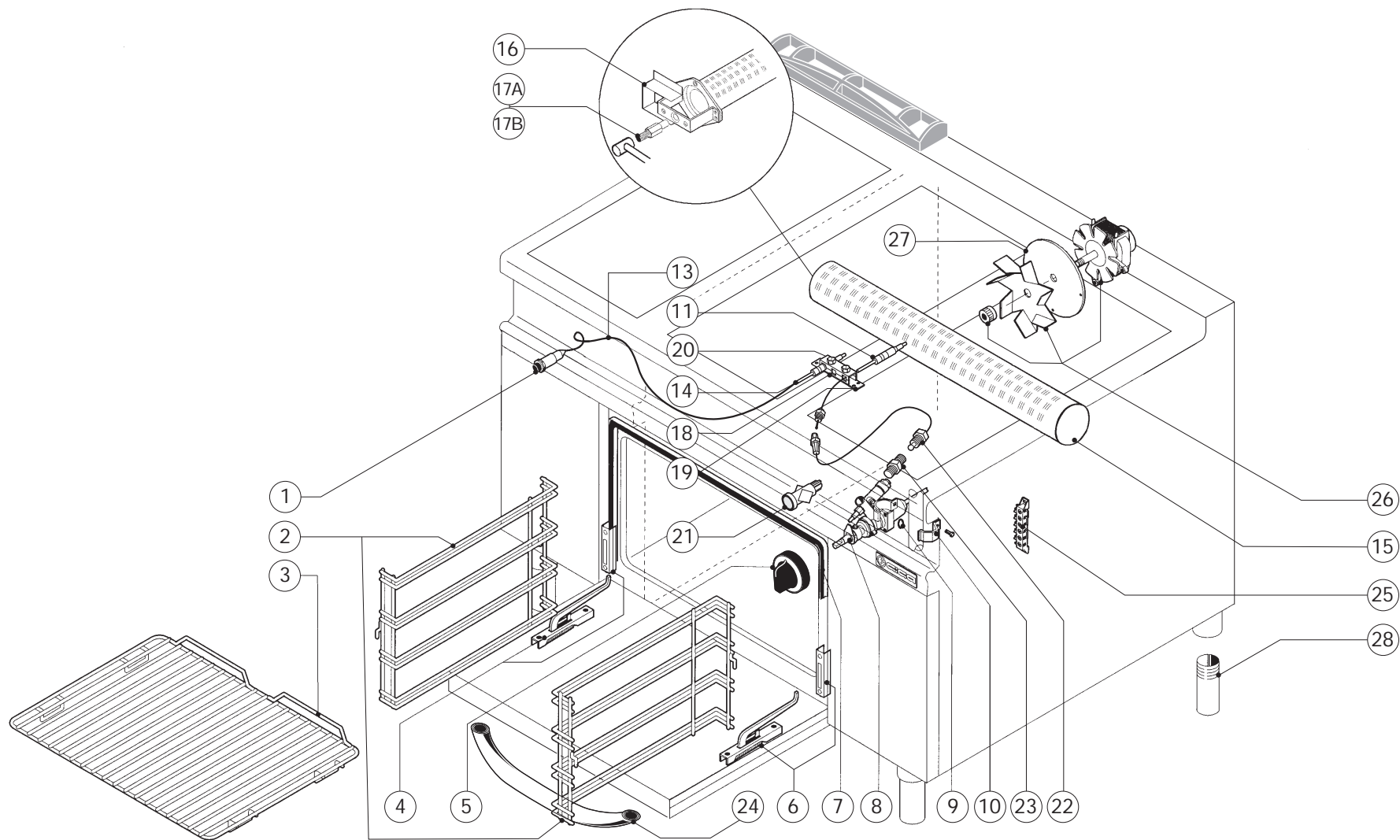

A = GPL / LP gas / Gaz liquide / Flüssiggas  
 B = Gas metano / Natural gas / Gaz naturel / Erdgas

N.B.: La tavola si completa con la successiva n° - See table No. - Voir tableau n° - Wichtig: S. folgender Plan Nr.

• 3E01-003  
K4FSFCG

• 3E01-012  
K4FZFCG - K6FZFCG  
K8FZFCG - K4FZSFCG

• 3E01-014  
KTPFCG - K2FTPFCG

**3E01-006**

K4FZFCG - K4FZSFCG - K4FSFCG  
KTPFCG - K2FTPFCG - K6FZFCG  
K8FZFCG

Pezzi/Pieces Pieces/Anzahl			Pos.	Validità dalla matricola Validité du numéro matricule Validity from serial number Gültigkeit ab der (Seriennummer)	Validità alla matricola Validity up to serial number Validité au numéro matricule Gültigkeit bis zur (Seriennummer)	Codice Code Artikel Nummer	Descrizione	Description	Description	Beschreibung
K4FZFCG K4FZSFCG K4FSFCG KTPFCG	K6FZFCG K2FTPFCG	K8FZFCG								
1	1	2	1			M02100	Piezo elettrico	Piezo-electric ignition	Piezo électrique	Piezelektrischer Zünder
2	2	4	2			V05900	Reggigriglia sx/dx	R.H./L.H. Grid support	Appui grille gauche/droite	Rostauflegeschiene L.R.
1	1	2	3			G11PF	Griglia	Grid	Grille	Rost
1	1	2	4			X66100	Cerniera sx	L. H. Hinge	Charniere gauche	Scharnier Links
1	1	2	5			0000Y65009	Manopola per forno	Oven knob	Cle de commande pour four	Drehknopf für Ofen
1	1	2	6			X66000	Cerniera dx	R. H. Hinge	Charniere droite	Scharnier Rechts
1	1	2	7			1000X05600	Guarnizione porta	Door seal	Joint porte	Türdichtung
1	1	2	8			X16000	Rubinetto gas	Gas cock	Robinet gaz	Gashahn
1	1	2	9			X07000	Or	Or	Or	Or
1	1	2	10			X07400	Staffa fissaggio rubinetto	Tap fixing bracket	Support fixation du robinet	Hahnbefestigungsbügel
1	1	2	11			X13900	Termocoppia	Thermocouple	Thermocouple	Thermoelement
1	1	2	13			X40300	Cavo alta tensione	H.T. cable	Cable H.T.	Hochspannungsk.
1	1	2	14			X14600	Candeletta	Ignition plug	Bougie	Glühkerze
1	1	2	15			V06400	Brucciato	Burner	Bruleur	Brenner
1	1	2	16			V09600	Regolazione aria	Air regulator	Réglage d'air	Luftregler
1	1	2	17A			Y28000	Iniettore GPL	LPG/pilot injector	Injecteur veilleuse/GPL	Gasduse GPL Ofen
1	1	2	17B			Y31900	Iniettore Metano	Natural gas/pilot injector	Injecteur veilleuse/méthane	Gasduse Methanpilot
1	1	2	18			X19903	Staffa con attacco	Bracket with fixture	E'trier avec fixation	Bügel mit Aufhängung
1	1	2	19			X19902	Staffa semplice	Simple bracker	E'trier simple	Einfacher Bügel
1	1	2	20			X19904	Vite per staffa	Screw for bracket	Vis pour bride	Schrauben für Halterung
1	1	2	21			X50900	Lampada verde	Green light	Lampe vert	Grüne Kontrollampe
1	1	2	22			X19400	Prolunga termocoppia	Thermocouple extension	Rallonge thermocouple	Verlängerung Thermoelement
1	1	2	23			5730201	Raccordo forato termocoppia	Drilled coupling for thermocouple	Raccord perforé pour thermocouple	Gelochtes Anschlussstück für Therm.
1	1	2	24			Y65700	Maniglia forno	Oven handle	Poignée four	Backofengriff
1	1	1	25			X59000	Morsettiera	Terminal board	Barrette de raccordement	Klemmleiste
1	1	2	26			V03000	Motoventilatore	Electric fan	Moto-ventilateur	Motorventilator
1	1	2	27			V05400	Isolamento	Insulation	Isolation	Isolierung
4	4	4	28			Y40400	Piedino	Foot	Pied	Fuss