

TAV.227		Boiler gas	Bouilleur gaz	Gas boiler	Gasboiler	FGM062	FGM102
	Codice	Denominazione	Denominaton	Denominaton	Bezeichnung		
1	RTFOC00215	Boiler gas	Bouilleur gazaz electric	Gas boiler	Gasboiler	×	
1	RTFOC00225	Boiler gas	Bouilleur gaz	Gas boiler	Gasboiler	×	×
2	MPISO00011	Isolante	Panneau isolant	Insulating panel	Isolier tafel	×	×
3	RTFOC00213	Guarnizione valvola peso	Guarniture valve	Valve gasket	Dichtung	×	×
4	RTFOC00212	Valvola peso	Valve	Valve	Ventil	×	×
5	RTFOC00056	Manopola scarico	Manette évacuation	Drain knob	Drehknopf	×	
6	GAFOC00105	Camino interno	Cheminée intérieur	Internal chimney	Innenschornstein	×	
6	GAFOC00112	Camino interno	Cheminée intérieur	Internal chimney	Innenschornstein		×
7	RTFOC00216	Tubo flessibile per camino	Tube flexible	Flexible pipe	Wasserablaßrohr	×	×
8	RTMIN00249	Fascetta Ø 77-97	Collier Ø 77-97	Clamp Ø 77-97	Windel Ø 77-97	×	×
9	RTFOC00186	Dado 3/4"	Ecrou 3/4"	Nut 3/4"	Mutter 3/4"	×	×
10	PAFOC00207	Deviatore fumi	Aiguilleur des fumées	Throttle	Rauchabweiser	×	×
11	GAFOC00111	Camino boiler	Cheminée bouilleur	Boiler chimney	Außenschornstein	×	
12	GAFOC00116	Camino boiler	Cheminée bouilleur	Boiler chimney	Außenschornstein		×
13	RTFOC00207	Sonda livello 160mm	Sonde niveau 160mm	Level probe 160mm	Niveaufühler 160mm	×	×
14	RTFOC00210	Sonda livello 130mm	Sonde niveau 130mm	Level probe 130mm	Niveaufühler 130mm	×	×
15	RTFOC00059	Asta attacco disco	Antenne disque évacuation	Moisture drain disk road	Kondenswasserablaßscheibe Stange	×	×
16	RTFOC00060	Asta posteriore scarico condensa.	Antenne arrière	Rear rod	Hintere Stange	×	×
17	RTFOC00109	Asta traversale scarico condensa.	Antenne transversale	Transverse rod	Querstange	×	×
18	RTCU900013	Calotta per tubo Ø 10	Ecrou pour tube Ø 10	Nut for pipe	Mutter für Schlauch Ø 10	×	×
19	RTFOC00062	Asta anteriore scarico condensa.	Antenne avant	Front rod	Vordere Stange	×	×
20	RTFOC00124	Gomito scarico condensa.	Coude évacuation condensator	Moisture drain elbow	Kondenswasserablaßkniestück	×	×
21	RTFOC00152	Rampa scarico cond.	Rampe évacuation condensator	Moisture drain ramp	Kondenswasserablaßrampe	×	×
22	PAFOC00204	Tubo scarico acqua	Tube de decharge de l'eau	Water dicharge pipe	Wasserablaßrohr	×	×
23	RTFOC00226	Tubo alimentazione acqua	Tube alimentation de l'eau	Water feeding pipe	Versorgungsrohr	×	×
24	RTFOC00275	Termostato elettrico	Thermostat	Thermostat	Thermostat	×	×
25	PACP800062	Squadretta portatermostato	Egierre de fixation thermostat	Bracket to fix thermostat	Winkel	×	×
26	RTFOC00145	Regolatore elettrovalvola Ø 1,20	Regulateur electrovanne Ø 1,20	Solenoid valve regulator Ø 1,20	E-Ventil Regler Ø 1,20	×	×
27	RTMIN00221	Fascetta Ø 14-22	Collier Ø 14-22	Clamp Ø 14-22	Windel Ø 14-22	×	×
28	MPGOM10T00	Tubo gomma Ø 10x17	Tuyau Ø 10x17	Pipe Ø 10x17	Rohr Ø 10x17	×	×
29	RTFOC00022	Elettrovalvola 1 via	Electrovanne 1 voie	Solenoid valve 1 way	E-Ventil 1 Weg	×	×
30	RTFOC00120	Regolatore elettrovalvola Ø 0,25	Regulateur electrovanne Ø 0,25	Solenoid valve regulator Ø 0,25	Brennkammer	×	×
31	RTFOC00203	Elettrovalvola 2 vie	Electrovanne 2 voies	Solenoid valve 2 ways	E-Ventil 2 Wege	×	×
32	RTFOC00100	Guarnizione rampa	Garniture	Gasket	Dichtung	×	×
33	RTFOC00204	Rampa alimentazione gas	Collecteur d'alimentation	Oven collector	Speiserampe	×	×
34	RTCP900087	Niples 1/2"-M20	Niples 1/2"-M20	Niples 1/2"-M20	Nippel 1/2"-M20	×	×
35	RTCP900088	Bicono per tubo Ø 14	Bicone our tube Ø 14	Bicone for pipe Ø 14	Zweikegel Ø 14	×	×
36	RTCP900089	Calotta per tubo Ø 14	Ecrou pou tube Ø 14	Nut for pipe Ø 14	Mutter für Schlauch Ø 14	×	×
37	RTCU900012	Bicono per tubo Ø 10	Bicone pour tube Ø 10	Bicone for pipe Ø 10	Zweikegel Ø 10	×	×
38	RTFOC00136	Rubinetto sfera mignon	Robinet de decharge	Water dicharge tap	Ablaßhahn	×	×
39	PACP800010	Tubo flessibile	Tube flexible	Flexible pipe	Wasserablaßrohr	×	×
40	RTFOC00206	Iniettore Ø 1,55 per GPL	Injecteur Ø 1,55 pour GPL	GPL injector Ø 1,55	Flüssiggas-Einspritzer Ø 1,55	×	×
40	RTFOC00281	Iniettore Ø 2,35 per gas metano	Injecteur Ø 2,35 pour méthane	Methane injector Ø 2,35	Methangas-Einspritzer Ø 2,35	×	×
41	GAFOC00208	Brucciato boiler	Brûleur bouilleur	Boiler burner	Brenner	×	×
42	RTCP800013	Controdado 1/2"	Countre écrou 1/2"	Lock nut 1/2"	Gegenmutter 1/2"	×	×
43	RTCP800012	Supporto iniettore	Support injecteur	Injector support	Einspritzerhalteung	×	×
44	RTBF800137	Bicono per tubo Ø 14	Bicone pour tube Ø 14	Bicone for pipe Ø 14	Zweikegel Ø 14	×	×

TAV.227		Boiler gas	Bouilleur gaz	Gas boiler	Gasboiler	FGM062	FGM102
	Codice	Denominazione	Denominaton	Denominaton	Bezeichnung		
45	RTBF800015	Calotta per tubo Ø 14	Ecrou our tube Ø 14	Nut for pipe Ø 14	Mutter für Schlauch Ø 14	×	×
46	PAFOC00213	Tubo alimentazione bruciatore	Tube alimentation du brûleur	Burner feeding pipe	Brennversorgungsrohr	×	×
47	PAFOC00262	Supporto motoriduttore	Support électroréducteur	Electric motor reducer support	Halterung	×	×
48	RTFOC00197	Motoriduttore boiler	Electroréducteur	Electric motor reducer	Electronic motor reducer	×	×
49	RTFOC00198	Microinietttore	Microswitch	Microswitch	Microswitch	×	×
50	RTFOC00192	Albero rubinetto sfera	Arbre du robinet de decharge	Tap shaft	Hahnverlängeung	×	×
51	PAFOC00210	Sostegno boiler	Support du bouilleur	Boiler support	Boiler Halteung	×	×
52	MPISO00013	Isolante	Panneau isolant	Insulating panel	Isoliertafel	×	×
53	PAFOC00250	Candela rilevamento fiamma	Bougie de relevé	Plug	Zündkerze	×	×
54	GAFOC00115	Camera di combustione	Chambre de combustion	Combustion chamber	Brennkammer	×	×
55	PAFOC00251	Candela accensione	Bougie d'allumage	Spark plug	Zündkerze	×	×
56	PAFOC00247	Coperchio ispezione boiler	Couvercle du boilleur	Boiler cover	Topfdeckel	×	×

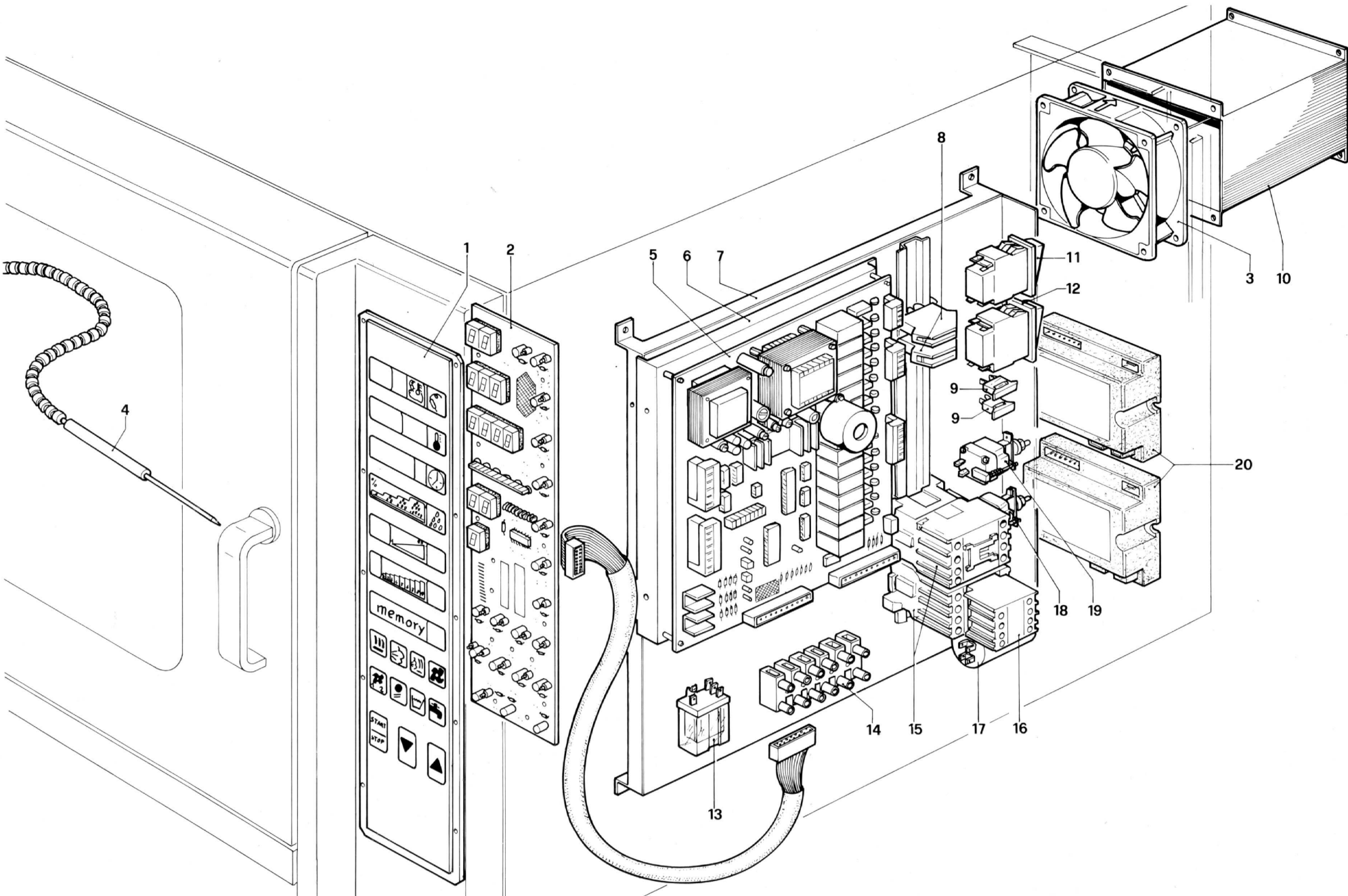

TAV.228		Apparecchiature elettriche	Appareillages électriques	Electrical equipment	Elektrogeräte	FGM062	FGM102
	Codice	Denominazione	Denominaton	Denominaton	Bezeichnung		
1	RTFOC00191	Mascherina cruscotto	Panneau de contrôle	Control panel	Steuertafel	×	×
2	RTFOC00194	Scheda elettronica comandi	Fiche électronique	Electronics card	Elektronische Komponenten	×	×
3	RTFOC00254	Motore e ventilatore	Ventilateur électrique	Electric ventilator	Ventilatorlau	×	×
4	RTFOC00130	Sonda al cuore 55cm	Sonde thermique 55cm	Thermic probe 55cm	Wärmefühler 55cm	×	
4	RTFOC00131	Sonda al cuore 82cm	Sonde thermique 82cm	Thermic probe 82cm	Wärmefühler 82cm		×
5	RTFOC00195	Scheda elettronica controllo	Fiche électronique	Electronics card	Elektronische Komponenten	×	×
6	PAFOC00237	Supporto scheda elettronica	Support fiche électronique	Electronics card support	Halterung	×	×
7	PAFOC00029	Supporto componenti elettrici	Support composant électriques	Electrical components support	Halterung elektronischer Komponenten	×	×
8	RTFOC00048	Portafusibile	Porte-fusible	Fuse-holder	Sicherungshalter	×	×
9	RTFOC00284	Fusibile 6,3A	Fusibile 6,3A	Fuse 6,3A	Schmelzsicherung 6,3A	×	×
10	GAFOC00118	Convogliatore calore	Convoyeur de charleur	Heat conveyer	Wärmeförder	×	×
11	RTFOC00044	Termica 0,8A	Interrupteur thermique 0,8A	Overload switch 0,8A	Thermostatschutzschalter 0,8A	×	
11	RTFOC00129	Termica 0,6A	Interrupteur thermique 0,6A	Overload switch 0,6A	Thermostatschutzschalter 0,6A		×
12	RTFOC00045	Termica 3A	Interrupteur thermique 3A	Overload switch 3A	Thermostatschutzschalter 3A	×	
12	RTFOC00074	Termica 1,8A	Interrupteur thermique 1,8A	Overload switch 1,8A	Thermostatschutzschalter 1,8A		×
13	RTFOC00144	Relais boiler	Relais bouilleur	Boiler relais	Relais	×	×
14	RTBF900045	Morsettiera 6 poli	Groupe de connection des cables	Terminal bloc 6 poles	Klemmbrett 6 polig	×	×
15	RTFOC00171	Relais	Relais	Relais	Relais	×	×
16	RTFOC00041	Contatti ausiliari	Contacts auxiliaires	Auxiliary contacts	Nebenkontakte	×	×
17	RTFOC00256	Condensatore	Condensateur	Condenser	Kondensator	×	×
18	RTFOC00230	Termostato Limit	Termostat Limit	Limit thermostat	Limit Thermostat	×	
18	RTFOC00231	Termostato Limit	Termostat Limit	Limit thermostat	Limit Thermostat		×
19	RTFOC00232	Termostato Limit	Termostat Limit	Limit thermostat	Limit Thermostat	×	×
20	RTFOC00260	Centralina accensione	Allumage électrique	Electric lighting	Elektrischer Anzünder	×	×

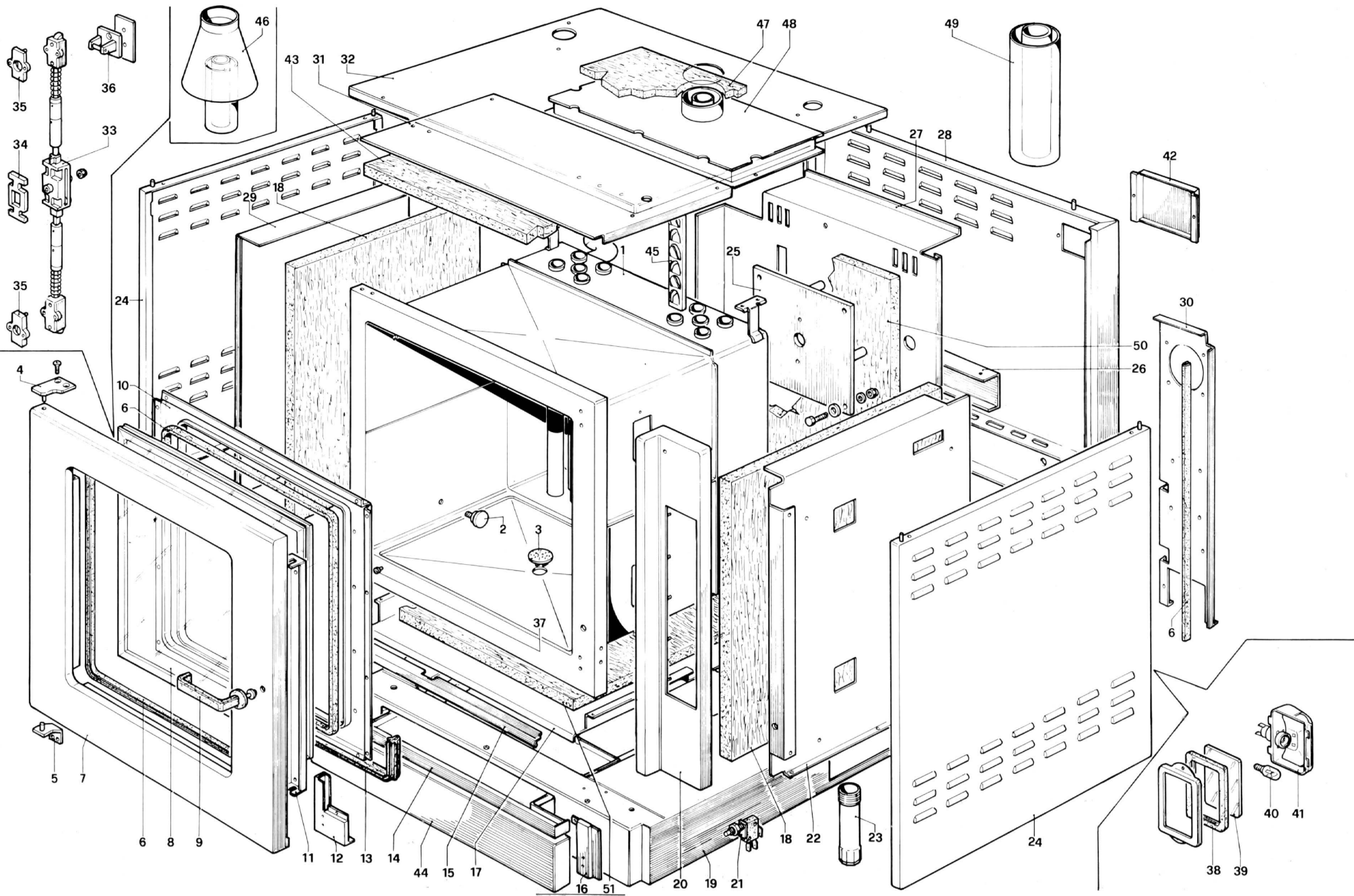

TAV.229		Struttura	Structure	Structure	Struktur	FGM102
	Codice	Denominazione	Denominaton	Denominaton	Bezeichnung	
1	GAFOC00065	Cassone forno	Caisson du four	Oven body	Ofenschublade	×
2	RTCU700002	Attacco griglia laterale	Attaque latérale	Lateral connection	Seitenanschluß	×
3	PAFOC00027	Disco copriforo	Disque	Disk	Scheibe	×
4	GAFOC00030	Cerniera superiore porta	Charnière supérieure	Upper hinge	Linke Türangel	×
5	GAFOC00031	Cerniera inferiore porta	Charnière inférieure	Lower door hinge	Untere Türangel	×
6	MPGOM03P00	Guarnizione vetro porta	Guarniture porte	Oven door gasket	Türdichtung	×
7	GAFOC00049	Porta forno	Porte du four	Oven door	Ofentür	×
8	RTFOC00065	Cristallo porta forno	Verre porte four	Oven door glass	Ofentürglas	×
9	RTFOC00007	Maniglia serratura	Poignée porte four	Oven door handle	Ofentürgriff	×
10	PAFOC00064	Controporta forno	Contre porte du four	Oven counter door	Gegentür	×
11	PAFOC00063	Protezione serratura porta	Protection de la serrure	Lock guard	Schloßschutz	×
12	PAFOC00085	Prolunga sinistra facciata	Rollange gauche tacade	Left facade extension	Verlängerung linke Front	×
13	RTFOC00094	Guarnizione porta forno	Guarniture porte du four	Oven door gasket	Türdichtung	×
14	GAFOC00048	Cassetto	Tiroir	Drawer	Kasten	×
15	PAFOC00181	Traversa antigoccia	Traverse anti-goutte	Anti-drip crosspiece	Tropfschutzquerstange	×
16	PAFOC00084	Prolunga destra facciata	Rollange droite facade	Right facade extension	Verlängerung rechte Front	×
17	PAFOC00080	Coprilana inferiore	Panneau couver isolant	Insulating panel cover	Isoliermaterialverkleidung	×
18	RTFOC00248	Pannello isolante laterale	Panneau isolant	Insulating panel	Isolierplatte	×
19	GAFOC00068	Basamento	Soubassement	Base	Untergestell	×
20	GAFOC00121	Cruscotto	Panneau de contrôle	Control panel	Stirnbrett	×
21	RTFOC00035	Microinterruttore	Microswitch	Microswitch	Microswitch	×
22	PAFOC00066	Coprilana destro	Panneau couvre isolant	Insulating panel cover	Isoliermaterialverkleidung	×
23	RTFOC00086	Piedino	Pied	Foot	Inox-Fuß	×
24	PAFOC00246	Fianco inox	Côté inox	Inox side	Inox-Seite	×
25	GAFOC00053	Supporto ventola	Support ventilateur	Fan support	Lautradsupport	×
26	PAFOC00081	Coprilana inf. posteriore	Panneau couvre isolant	Insulating panel cover	Isoliermaterialverkleidung	×
27	PAFOC00067	Coprilana posteriore	Panneau couvre isolant	Insulating panel cover	Isoliermaterialverkleidung	×
28	GAFOC00120	Posteriore inox	Panneau postérieur inox	Inox back panel	Inox-Rückwand	×
29	PAFOC00065	Coprilana sinistro	Panneau couvre isolant	Insulating panel cover	Isoliermaterialverkleidung	×
30	PAFOC00233	Protezione comp. elettrici.	Protection composant électriques	Electrical components guard	Schutz elektrischen Komponenten	×
31	PAFOC00141	Coprilana superiore	Panneau couvre isolant	Insulating panel cover	Isoliermaterialverkleidung	×
32	GAFOC00114	Coperchio	Couvercle	Cover	Topfdeckel	×
33	GAFOC00051	Serratura porta forno	Serrure porte four	Oven door lock	Ofentürschloß	×
34	RTFOC00057	Zoccolo centrale serratura	Prise centrale serrure	Central connection lock	Mittlerer Anschluß	×
35	RTFOC00005	Zoccolo esterno serratura	Prise extérieure serrure	External connection lock	Äußerer Anschluß	×
36	RTFOC00009	Gancio fisso serratura	Crochet fixe de la serrure	Lock fixed hook	Fester Schlossnaken	×
37	RTFBF800021	Gommino porta forno	Bouchon de la porte	Door rubber cap	Türgummi	×
38	RTFOC00202	Guarnizione portalampada	Garniture	Gasket	Dichtung	×
39	RTFOC00201	Vetro portalampada	Verre protège ampoule	Lamp-holden glass	Leuchtenhalterungsglass	×
40	RTFOC00037	Lampada 25W 220V	Ampoule 25W 220V	Lamp 25W 220V	Leuchte 25W 220V	×
41	RTFOC00036	Portalampada	Douille	Lamp-holder	Leuchtenhalterung	×
42	PAFOC00234	Protezione convogliatore calore	Protection convoyeur	Heat conveyor guard	Schutz Wärmeförderer	×
43	RTFOC00243	Pannello isolante superiore	Panneau isolant supér.	Upper insulating panel	Linke Isoliertafel	×
44	PAFOC00092	Pannella inferiore	Panneau inférieur	Lower panel	Untere Tafel	×
45	PAFOC00122	Deviatore fumi	Aiguilleur des fumées	Throttle	Rauchabweiser	×
46	AFC0000090	Camino antivento	Cheminée antirefuleur	Chimney	Schornstein	×
47	MPIS000013	Pannello isolante camino sup.	Panneau isolant cheminé	Chimney insulating panel	Schornstein Isoliertafel	×

TAV.229		Struttura	Structure	Structure	Struktur	FGM102
	Codice	Denominazione	Denominaton	Denominaton	Bezeichnung	
48	GAFOC00112	Camino interno	Cheminée intérieur	Internal chimney	Innenschornstein	×
49	RTFOC00227	Camino superiore	Cheminée supérieur	Upper insulating panel	Linker Schornstein	×
50	RTFOC00244	Pannello isolante posteriore	Panneau isolant postérieur	Rear insulating panel	Isolier tafel	×
51	RTFOC00242	Pannello isolante fondo	Panneau isolant fond	Bottom insulating panel	Isolier tafel	×

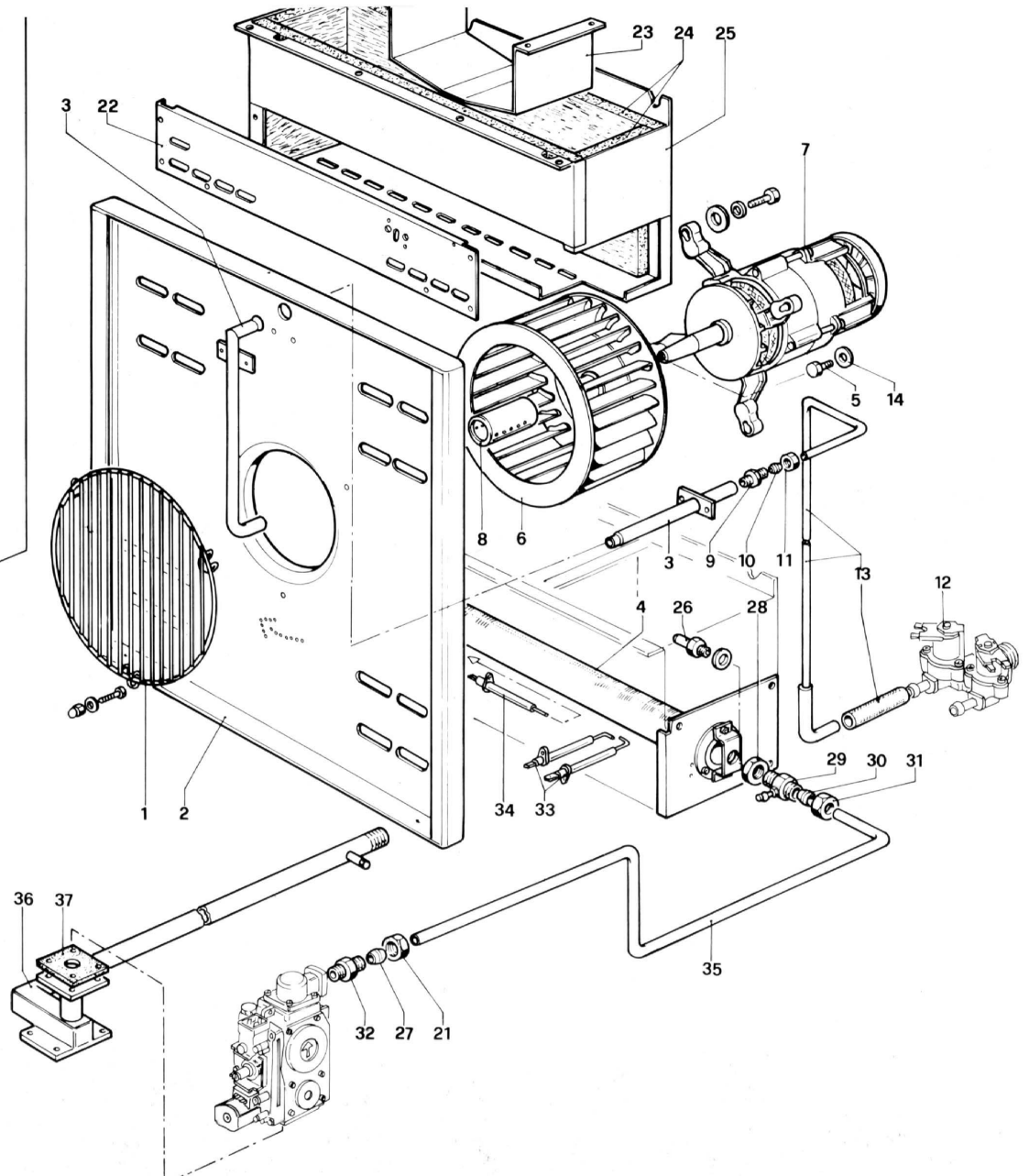
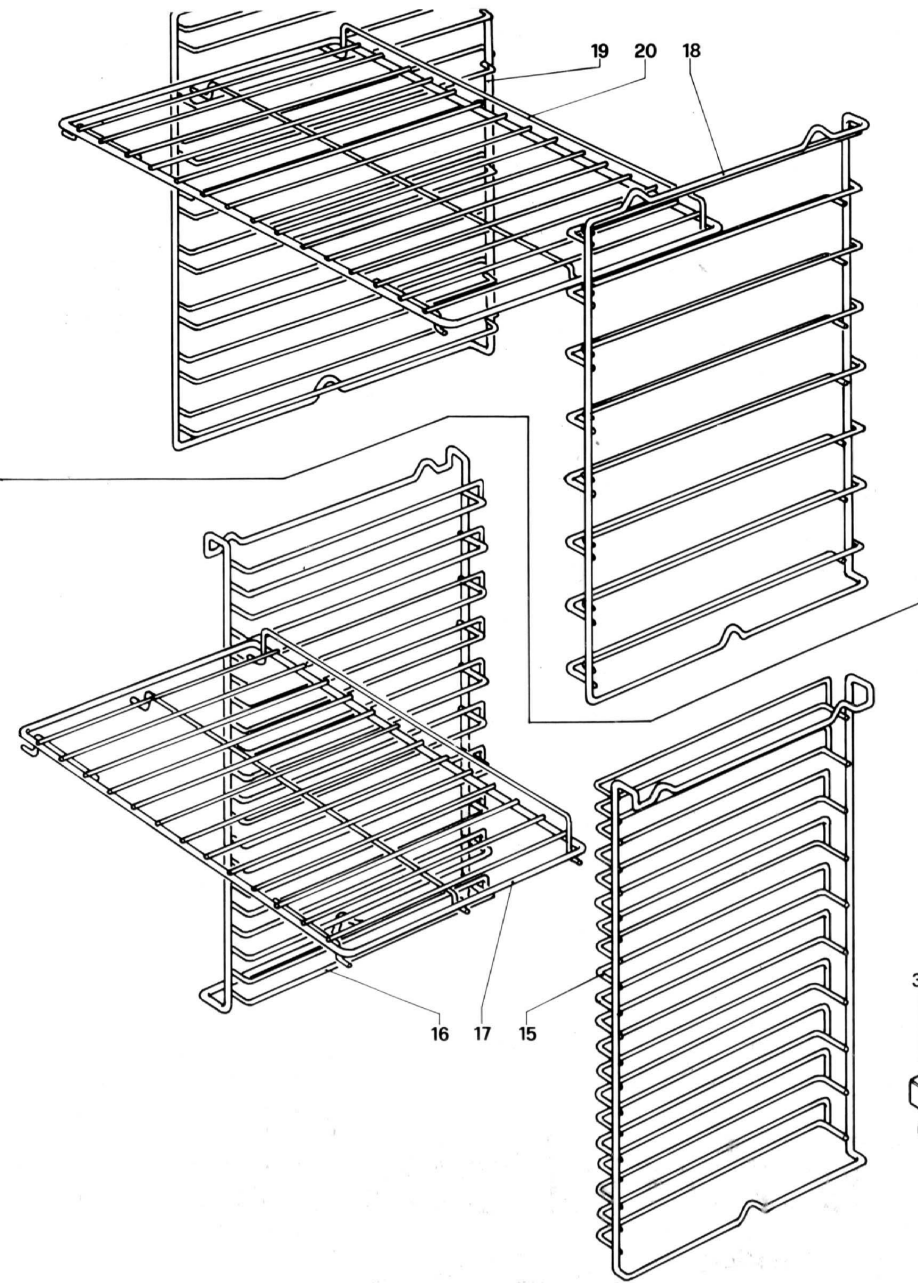

TAV. 230		Griglie e impianto gas	Grilles et installation gaz	Grilles and gas system	Gitter und Gasanlage	FGM102
	Codice	Denominazione	Denominaton	Denominaton	Bezeichnung	
1	RTFOC00174	Griglia protezione ventilatore	Grille ventilateur	Fan grille	Ventilatorgitter	×
2	GAFOC00054	Convogliatore aria	Coiffe ventilateur air	Air duct	Luffförderer	×
3	RTFOC00071	Umidificatore	Humidificateur	Humidifier	Befeuter	×
4	GAFOC00073	Brucciatore	Brûleur	Burner	Brenner	×
5	RTFOC00118	Vite fissaggio girante	Vis de fixation couronne mobile	Wheel attachment screws	Lauf radbefestigungsschraube	×
6	RTFOC00067	Girante ventilatore	Couronne mobile ventilateur	Fan wheel	Ventilatorlaufrad	×
7	RTFOC00066	Motore elettrico	Moteur électrique	Electric motor	E-Motor	×
8	RTFOC00156	Nebulizzatore	Nébulisateur	Atomizer	Zerstäuber	×
9	RTFOC00019	Iniettore umidificatore	Injector humidificateur	Injector for humidifier	Einspritzer für Befeuchter	×
10	RTCU800183	Bicono Ø 6	Bicône pour tube Ø 6	Bicone for pipe Ø 6	Zweikegel Ø 6	×
11	RTFOC00020	Calotta Ø 6	Ecrou pour tube Ø 6	Nut for pipe Ø 6	Mutter für Schlauch Ø 6	×
12	RTFOC00203	Elettrovalvola	Electrovanne	Solenoid valve	E-Ventil	×
13	RTFOC00072	Tubo alimentazione umidificatore	Tube alimentation	Feeding pipe	Versorgungsrohr	×
14	RTFOC00301	Anello tenuta perno motore	Rondelle de joint	Ring	Ring	×
15	RTFOC00178	Griglia laterale destra	Grille latérale droite	Right lateral grate	Rechter Seitenrost	×
16	RTFOC00181	Griglia laterale sinistra	Grille latérale gauche	Left lateral grate	Linker Seitenrost	×
17	RTFOC00175	Griglia forno	Grille du four	Oven grate	Ofenrost	×
18	RTFOC00114	Griglia laterale destra (Pasticceria)	Grille latérale droite (Pâtisserie)	Right lateral grate (Confectionery)	Rechter Seitenrost (Konditorei)	×
19	RTFOC00113	Griglia laterale sinistra (Pasticceria)	Grille latérale gauche (Pâtisserie)	Left lateral grate (Confectionery)	Linker Seitenrost (Konditorei)	×
20	RTFOC00083	Griglia forno (Pasticceria)	Grille du four (Pâtisserie)	Oven grate (Confectionery)	Ofenrost(Konditorei)	×
21	RTCP900089	Calotta Ø 14	Écrou pour tube Ø 14	Nut for pipe Ø 14	Mutter für Schlauch Ø 14	×
22	PAFOC00245	Coperchio camera combustione	Panneau antérieur chambre comb.	Combustion chamber face	Brennkammervorderwand	×
23	PAFOC00124	Deflettore bruciatore	Déфлектор pour brûleur	Burner deflector	Deflektor	×
24	MPIS000013	Pannello isolante	Panneau isolant	Insulating panel	Isolier tafel	×
25	GAFOC00072	Camera di combustione	Chambre de combustion	Combustion chamber	Brennkammer	×
26	RTCP800016	Iniettore Ø 1.70 K per GPL	Injector Ø 1.70 K pour GPL	L.P.G. Injector Ø 1.70 K	Flüssiggas-Einspritzer Ø 1.70 K	×
26	RTCP800168	Iniettore Ø 3.15 gas metano	Injecteur Ø 3.15 pour méthane	Methane pilot injector Ø 3.15 K	Methangas-Einspritzer Ø 3.15 K	×
27	RTCP900088	Bicono Ø 14	Bicône Ø 14	Bicone Ø 14	Zweikegel Ø 14	×
28	RTCP800013	Controdado 1/2"	Countre écrou 1/2"	Lock nut 1/2"	Gegenmutter 1/2"	×
29	RTCP800012	Supporto iniettore	Support injecteur	Injector support	Einspritzhalterung	×
30	RTBF800137	Bicono Ø 14	Bicône Ø 14	Bicone Ø 14	Zweikegel Ø 14	×
31	RTBF800015	Calotta Ø 14	Écrou pour tube Ø 14	Nut for tube Ø 14	Mutter für Schlauch Ø 14	×
32	RTCP900087	Niples 1/2" - M20	Niples 1/2" -M20	Nipples 1/2" -M20	Nippel 1/2" -M20	×
33	PAFOC00252	Candeletta accensione	Bougie d'allumage	Spark plug	Zündkerze	×
34	PAFOC00249	Candeletta rilevamento	Bougie de relevé	Plug	Zündkerze	×
35	PAFOC00097	Tubo alimentazione bruciatore	Tube alimentation du brûleur	Burner feeding pipe	Brennerversorgungsrohr	×
36	RTFOC00204	Rampa forno	Collecteur du four	Oven collector	Speiserampe	×
37	RTFOC00100	Guarnizione rampa	Garniture collecteur	Collector gasket	Dichtung	×

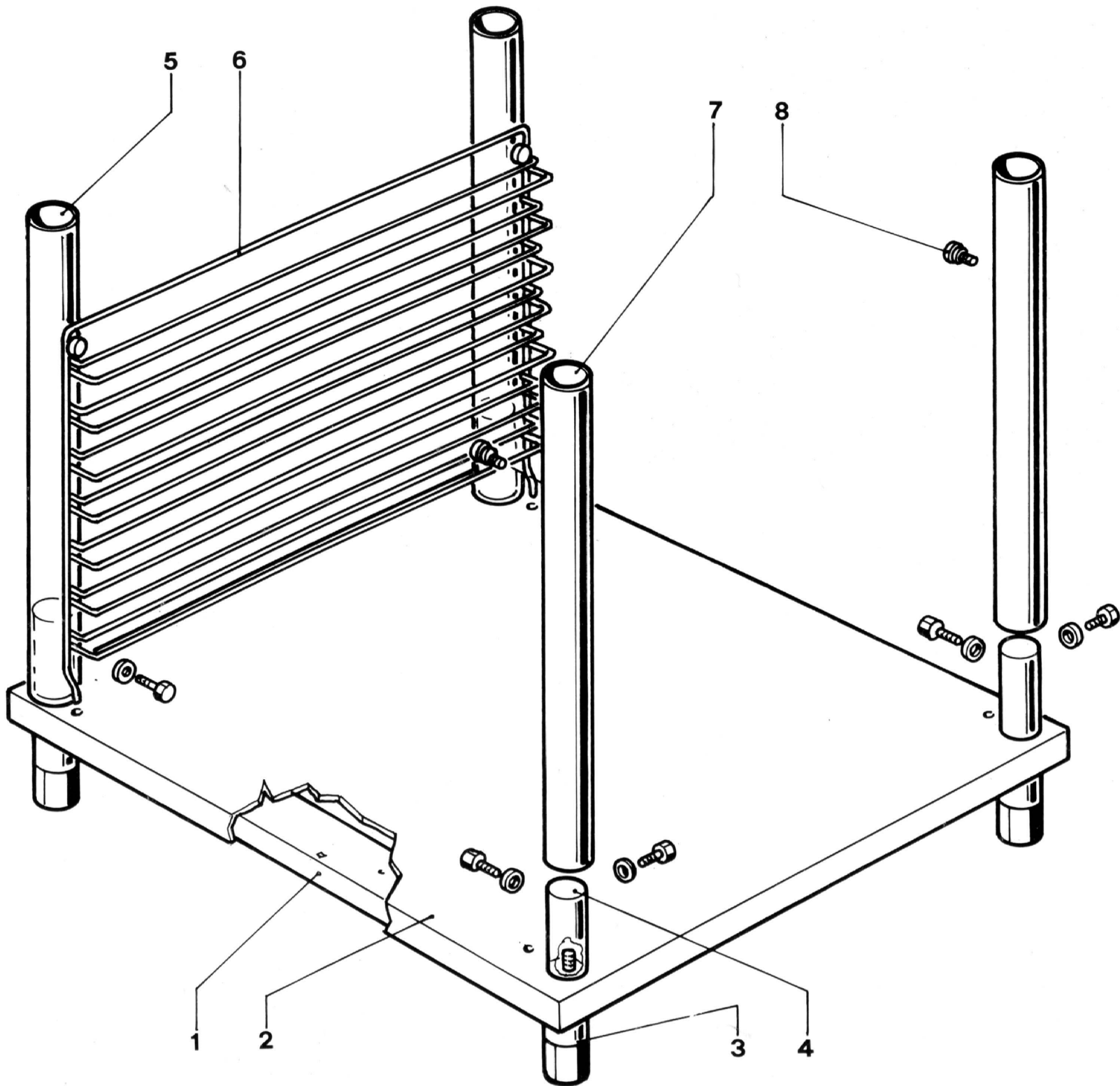

TAV.204		Supporto forno	Support du four	Oven support	Ofenhalterung	
	Codice	Denominazione	Denominaton	Denominaton	Bezeichnung	
1	GAFOC00077	Basamento supporto forno	Soubassement du support	Oven support base	Untergestell	×
2	PAFOC00133	Ripiano supporto forno	Fonde support du four	Oven support bottom	Boden	×
3	RTFOC00119	Piedino	Pied	Foot	Inox-Fuß	×
4	RTFOC00121	Rinforzo gamba	Rentort jambe	Leg bracing	Verstärkung	×
5	PAFOC00134	Gamba sinistra	Jambe gauche	Left leg	Linker Fuß	×
6	RTFOC00122	Griglia laterale	Grille latérale	Lateral grate	Seitenrost	×
7	PAFOC00135	Gamba destra	Jambe droite	Right leg	Rechter Fuß	×
8	RTBF700043	Attacco griglia	Attaque grille	Grate connection	Seitenanschluß	×