

NME654R & FME804R SERVICE PARTS

This parts list contains the service parts and wiring diagrams for this model. Check the model number in question to be sure that it is applicable to this parts list.

Note: The liquid line filter drier listed in this parts list is designed for this refrigeration system. Premature failure may result if the wrong drier is used.

TABLE OF CONTENTS

Cabinet	2
Refrigeration	3
NME Evaporator	4
FME Evaporator	5
Water System	6
Gear Motor	7
Control Box	8
Remote Condenser	9
Wiring Diagrams	10

NME654R & FME804R SERVICE PARTS

Cabinet Assembly

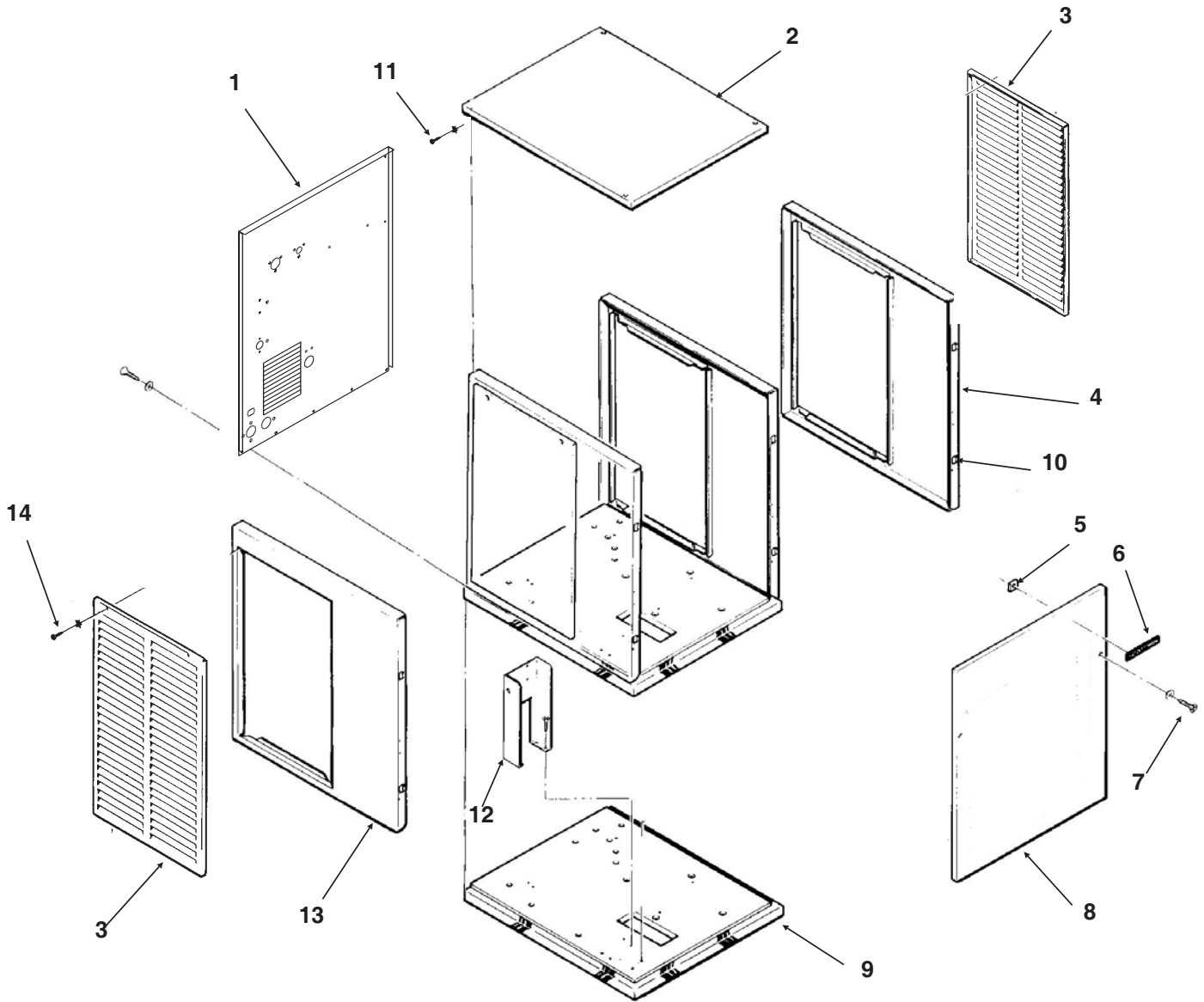

ITEM NUMBER	PART NUMBER	DESCRIPTION	ITEM NUMBER	PART NUMBER	DESCRIPTION
1	A35924-002	Back panel, stainless steel	7	03-1419-22	Screw
2	A33256-002	Top Panel, S.S.	8	A33255-002	Front Panel, louvered
3	A33946-032	Service Panel, louvered		A39048-001	Front panel, no louvers
4	A33292-002	Right Side Panel, S.S.	9	A35890-001	Base Assembly
5	03-0271-00	Speed Clip	10	02-0836-00	Catch
6	15-0808-01	Emblem		15-0411-00	Strike
				03-1406-04	Nut
			11	03-1531-01	Screw
			12	A34039-001	Control Box Support
			13	A32435-002	Left Side Panel, S.S.
			14	03-1404-12	Screw

NME654R & FME804R SERVICE PARTS

Refrigeration System

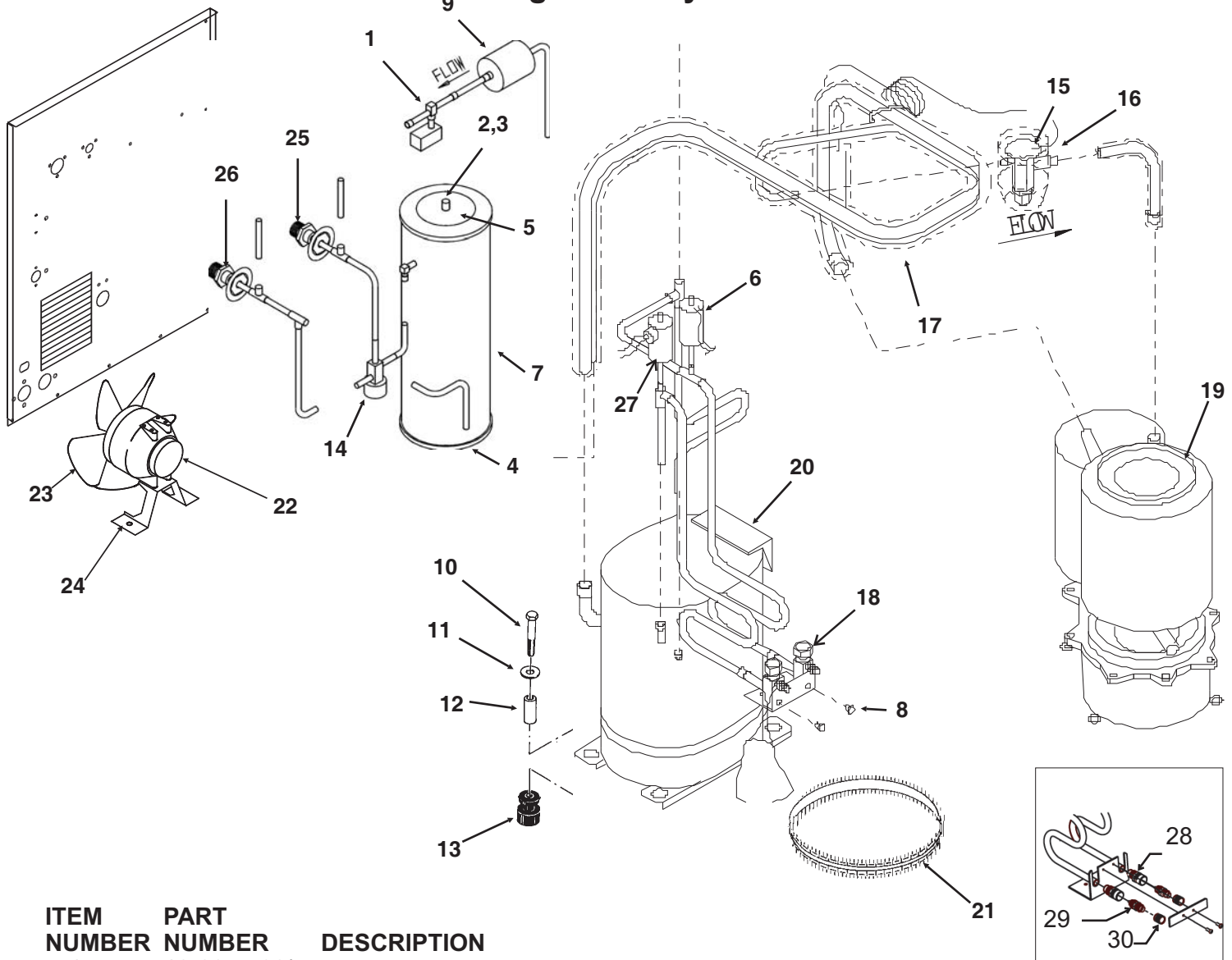

ITEM NUMBER	PART NUMBER	DESCRIPTION
1	12-2274-02*	Liquid line valve or
	12-2135-01*	Liquid line valve
2	03-1406-13	Nut
3	03-1410-06	Washer
4	A32968-001	Receiver Support
5	A31801-002	Receiver Bracket
6	11-0501-22	Hi Pressure Cut Out
7	16-0761-01	Receiver
8	03-1645-01	Cap Screw
9	02-3319-02	Dryer
10	03-1405-20	Cap Screw
11	03-1407-07	Washer
12	18-2200-27	Sleeve
13	18-2200-28	Rubber Grommet
14	11-0422-25	Head Pressure Valve
15	11-0488-21	Thermo Expansion Valve
16	A32961-020	Insulation Kit for TXV
17	A35870-001	Suction Line
18	16-0832-20	Access valve
18a	16-0832-02	Stem cap
18b	16-0832-03	Core cap
19	A33194-020	Evaporator - see page 6
20	18-8721-21	Compressor 115/60/1
	18-8711-50	Overload 115/60/1
21	12-1868-04	Crankcase Htr 115 v
22	12-1576-01	Fan motor
23	18-8708-01	Fan blade
24	A35246-001	Fan motor bracket
25	16-0850-03	Quick connect fitting, 3/8"
26	16-0850-01	Quick connect fitting, 1/2"
27	11-0502-21	Pump down control
28	16-1137-01	Access valve body
29	16-1139-01	Core
30	16-1140-01	Cap

* Either solenoid valve may be used.

NME654R & FME804R SERVICE PARTS

NME Evaporator, Bin Controls

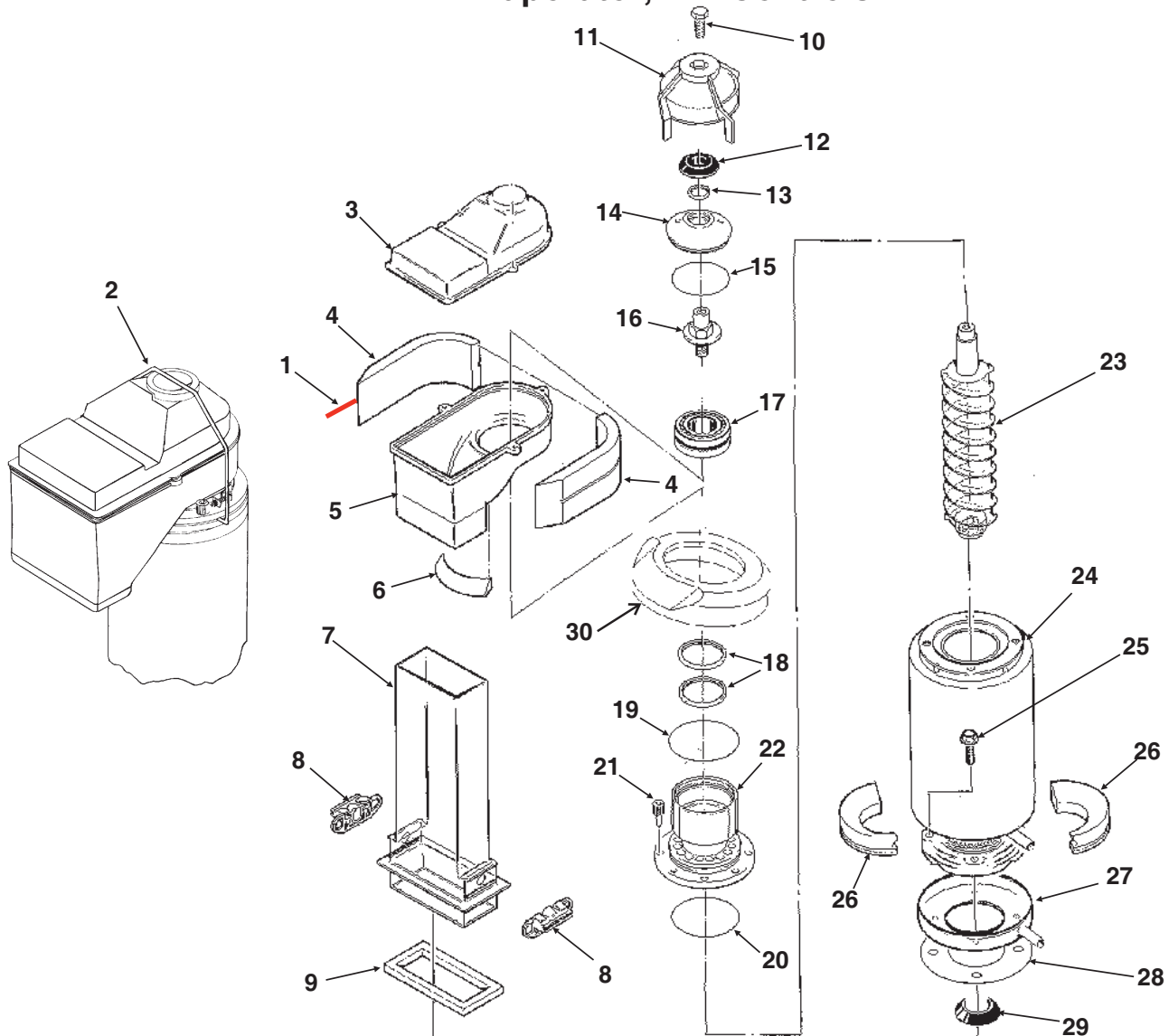

ITEM NUMBER	PART NUMBER	DESCRIPTION
1.	A35419-020	Strap kit*
2.	A34969-001	Bail clamp
3.	02-2930-04	Ice Chute Cover
4.	A32963-001	Insulation Top (half)*
5.	02-3841-01	Ice Chute Body w/ins*
6.	A33102-001	Insulation Collar Inside*
7.	02-2929-03	Ice Chute Lower
8.	A37708-021	Bin Controls Assy. (set of 2)
9.	A32930-001	Chute Gasket
10.	03-1405-52	Hex Cap Screw
11.	02-3001-01	Ice Sweep
12.	13-0871-01	Water Shed
13.	02-2978-01	Lip Seal
14.	02-3128-20	Breaker Cover
15.	13-0617-54	O-Ring
16.	08-0660-01	Auger Stud
17.	A34559-020	Bearing
18.	02-2977-01	Lip Seal
19.	13-0617-52	O-Ring
20.	13-0617-45	O-Ring
21.	03-1544-08	Soc. Head Screw
22.	A32900-020	Breaker (includes 18 & 19)
23.	A38071-021	Auger
24.	A33194-020	Evaporator
25.	03-1405-41	Cap Screw
26.	A32962-001	Insulation Bot. (half)
	A32962-002	Insulation half
27.	02-3837-01	Drip Pan
28.	13-0704-00	Drip Pan Gasket
29.	13-0868-01	Water Shed
30.	13-0929-02	Insulation donut*

* Insulation changed Oct. 2000. Item 30 added and item 5 changed at that time. Items 1, 4, and 6 not used after that.

NME654R & FME804R SERVICE PARTS

FME Evaporator

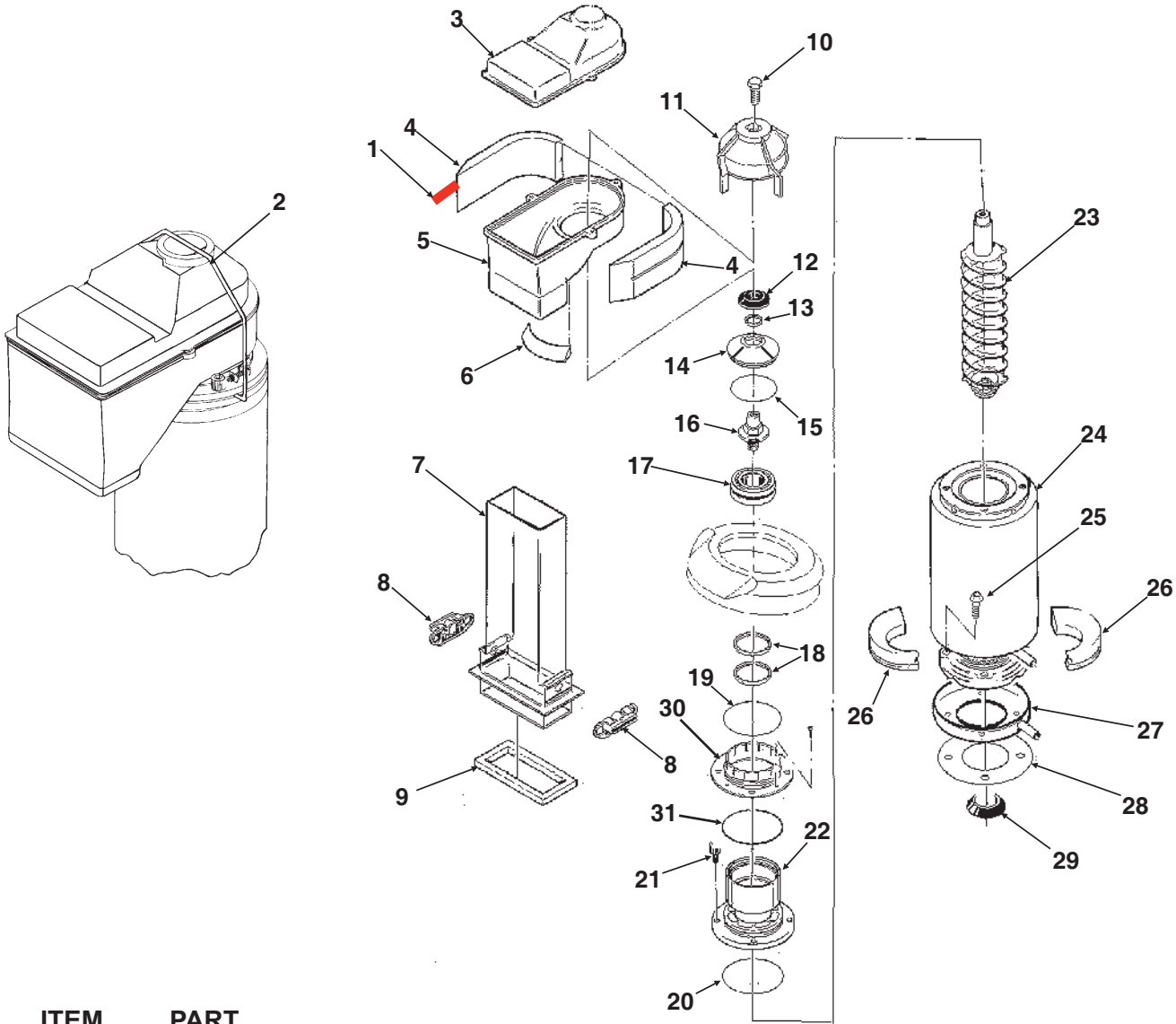

ITEM NUMBER	PART NUMBER	DESCRIPTION
1.	A35419-020	Strap kit*
2.	A34969-001	Bail clamp
3.	02-2930-04	Ice Chute Cover
4.	A32963-001	Insulation Top (half)*
5.	02-3841-01	Ice Chute Body w/ins*
6.	A33102-001	Insulation Collar Inside*
7.	02-2929-03	Ice Chute Lower
8.	A37708-021	Bin Controls Assy. (set of 2)
9.	A32930-001	Chute Gasket
10.	03-1405-52	Hex Cap Screw
11.	02-3001-01	Ice Sweep
12.	13-0871-01	Water Shed
13.	02-2978-01	Lip Seal
14.	02-3128-20	Breaker Cover
15.	13-0617-54	O-Ring
16.	08-0660-01	Auger Stud
17.	A34559-020	Bearing
18.	02-2977-01	Lip Seal
19.	13-0617-52	O-Ring
20.	13-0617-45	O-Ring
21.	03-1544-08	Soc. Head Screw
22.	A34505-020	Breaker (includes 18 & 19)
23.	A38071-021	Auger
24.	A33194-020	Evaporator
25.	03-1405-41	Cap Screw
26.	A32962-001	Insulation Bot. (half)
	A32962-002	Insulation half
27.	02-3837-01	Drip Pan
28.	13-0704-00	Drip Pan Gasket
29.	13-0868-01	Water Shed
30.	02-2916-01	Slotted collar
31.	13-0617-49	O-Ring
32.	13-0929-01	Insulation donut*

* Insulation changed Oct. 2000. Item 32 added and item 5 changed at that time. Items 1, 4, and 6 not used after that.

NME654R & FME804R SERVICE PARTS

Water System, Water Seal

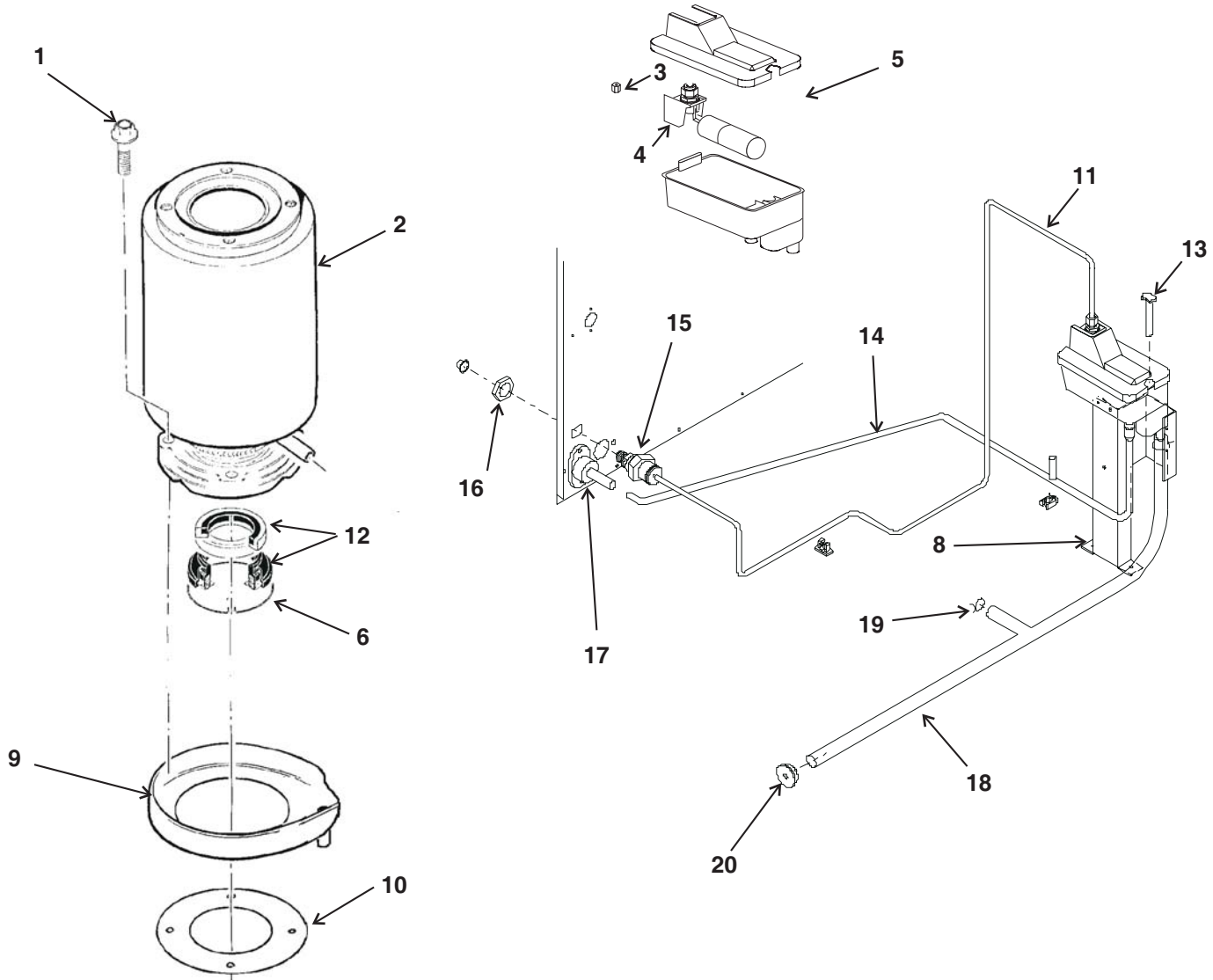

ITEM NUMBER	PART NUMBER	DESCRIPTION
1	03-1420-03	Cap Screw
2	A33194-020	Evaporator
3	02-3266-03	Valve seat
4	02-3266-21	Float valve and seat
5	02-3266-20	Reservoir Assembly
6	A32777-001	Retaining Ring for Seal
8	A36078-001	Reservoir bracket
9	02-3837-01	Drip Pan
10	13-0704-00	Gasket
11	13-0895-01	Inlet tubing, 4 ft req.
12	02-0929-23	Water Seal
13	12-2760-21	Water sensor

ITEM NUMBER	PART NUMBER	DESCRIPTION
14	02-3826-03	Res. overflow hose
15	16-0835-01	Water Inlet Fitting
	16-1039-01	Male connector
16	03-1394-01	Pal Nut
17	02-3692-02	Drain fitting
18	A36154-001	Evap. water inlet tube
19	02-1338-00	Hose clamp
20	13-0840-01	Plug

NME654R & FME804R SERVICE PARTS

Gearmotor

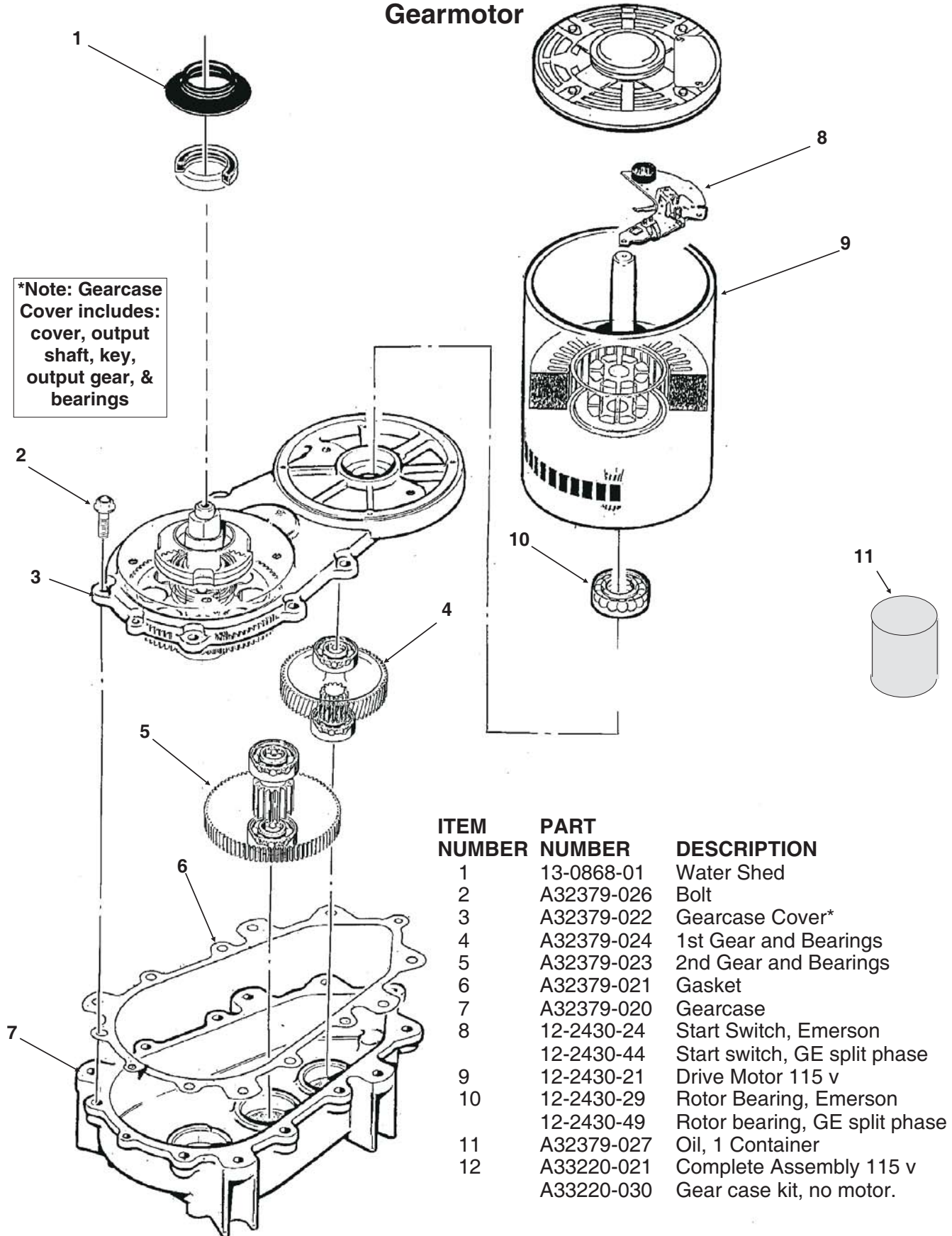

ITEM NUMBER	PART NUMBER	DESCRIPTION
1	13-0868-01	Water Shed
2	A32379-026	Bolt
3	A32379-022	Gearcase Cover*
4	A32379-024	1st Gear and Bearings
5	A32379-023	2nd Gear and Bearings
6	A32379-021	Gasket
7	A32379-020	Gearcase
8	12-2430-24	Start Switch, Emerson
	12-2430-44	Start switch, GE split phase
9	12-2430-21	Drive Motor 115 v
10	12-2430-29	Rotor Bearing, Emerson
	12-2430-49	Rotor bearing, GE split phase
11	A32379-027	Oil, 1 Container
12	A33220-021	Complete Assembly 115 v
	A33220-030	Gear case kit, no motor.

NME654R & FME804R SERVICE PARTS

Control Box

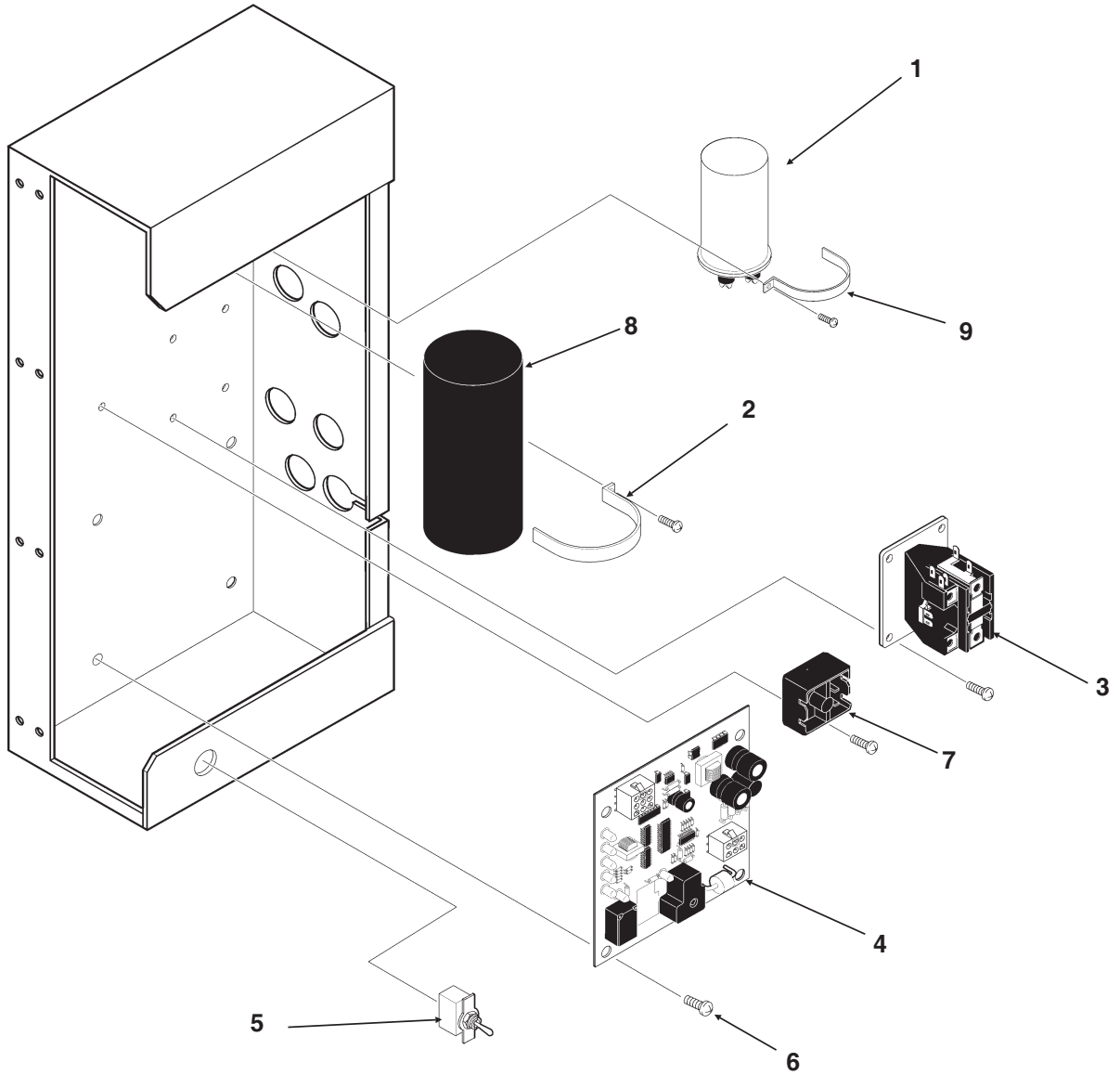

ITEM NUMBER	PART NUMBER	DESCRIPTION
1	18-1901-03	Start Cap
2.	A35971-002	Start Capacitor Bracket
3.	12-2469-03	Contactors
4	12-2835-21	Circuit Board
5.	12-0426-02	Master Switch
6.	12-2350-01	Stand off

ITEM NUMBER	PART NUMBER	DESCRIPTION
7	18-1903-50	Potential Relay
8	18-1902-45	Run capacitor
9	A35971-001	Run capacitor bracket
NOT ILLUSTRATED		
10	A37861-001	Control Box Cover

NME654R & FME804R SERVICE PARTS REMOTE CONDENSER

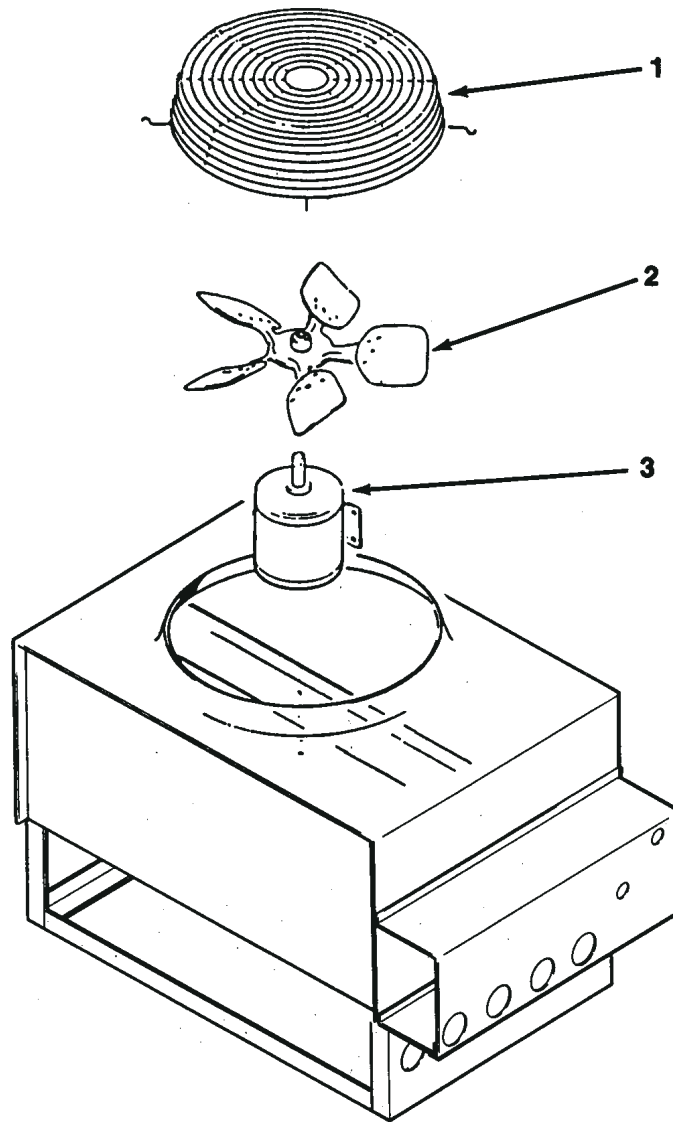

ERC101-1A

ITEM NUMBER	PART NUMBER	DESCRIPTION
1	02-3575-01	Fan guard
2	18-8800-01	Fan blade
3	18-8796-01	Fan motor

For pre-charged line sets:

4	16-1057-01	Female coupling (3/8")
5	16-1057-02	Female coupling (1/2")

NME654R & FME804R SERVICE PARTS

Component Layout Diagram

17-2704-01

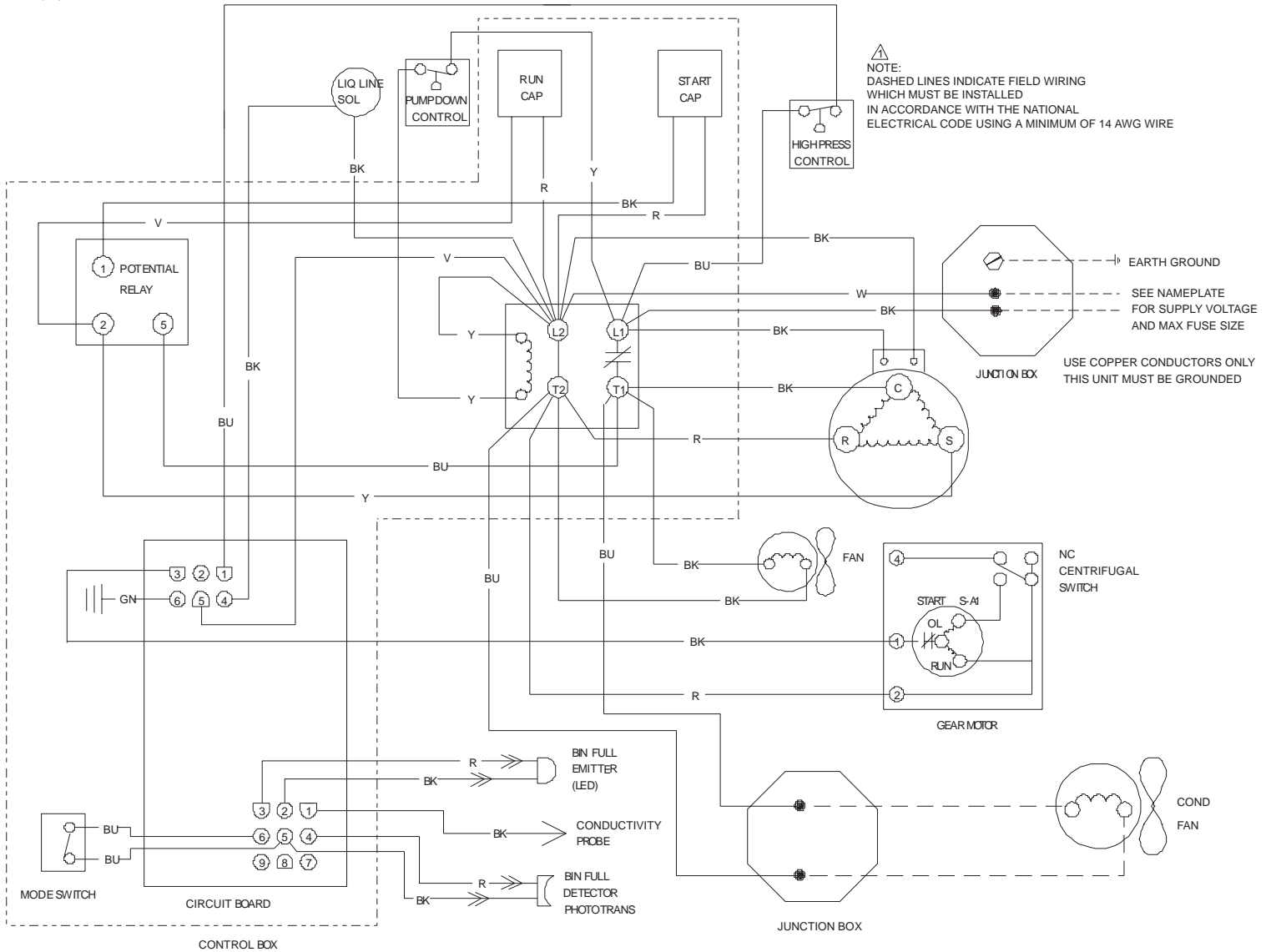

NME654R & FME804R SERVICE PARTS Schematic Diagram

