

# NME454, 654 & FME504, 804 SERVICE PARTS

This parts list contains the service parts and wiring diagrams for this model. Check the model number in question to be sure that it is applicable to this parts list. Caution: This model ice maker has been manufactured in two voltages: 115/60/1 and 230/50/1.

The model numbers for the 115/60/1 include:

- FME504AS-1A and FME504WS-1A
- FME804AS-1A and FME804WS-1A
- FME804AS-1B and FME804WS-1B
- NME454AS-1A and NME454WS-1A
- NME654AS-1A and NME654WS-1A
- NME654AS-1B and NME654WS-1B

The model numbers for the 230/50/1 include:

- FME804AS-6A and FME804WS-6A
- FME804AS-6B and FME804WS-6B
- NME654AS-6A and NME654WS-6A
- NME654AS-6B and NME654WS-6B

For electrical components, check to be certain that the part is the correct voltage for the machine.

## Table of Contents

Cabinet Assembly . . . . .	Page 2
Air Cooled Refrigeration . . . . .	Page 3
Water Cooled Refrigeration . . . . .	Page 4
Water System . . . . .	Page 5
Gearmotor . . . . .	Page 6
FME504 or FME804 Evaporator . . . . .	Page 7
NME454 or NME654 Evaporator . . . . .	Page 8
Control Box . . . . .	Page 9
NME654, FME804 Component Layout Diagram . . . . .	Page 10
NME654, FME804 Schematic Diagram . . . . .	Page 11
NME654 or FME804 -6 . . . . .	Page 12
NME454 or FME804 Wiring Diagram . . . . .	Page 13
NME454 or FME804 Schematic Diagram . . . . .	Page 14

# NME454, 654 & FME504, 804 SERVICE PARTS

## Cabinet Assembly

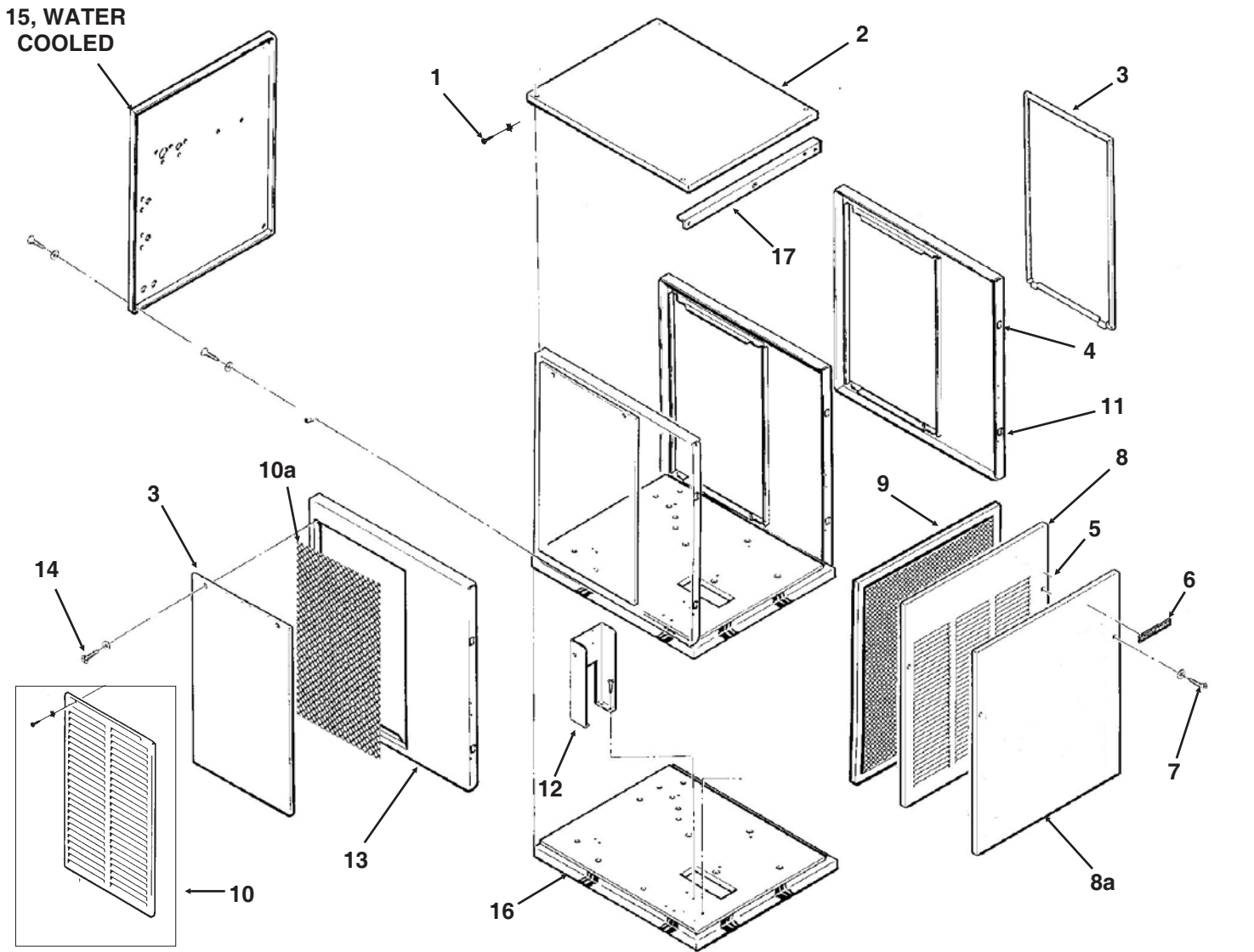

ITEM NUMBER	PART NUMBER	DESCRIPTION	ITEM NUMBER	PART NUMBER	DESCRIPTION
1	03-1531-01	Screw	10	A33946-002	Louvered service panel
2	A33256-002	Top panel, S.S.	10a	A32975-001	Air filter media
3	A34038-002	Non- louvered service panel	11	02-0836-00	Catch
4	A33292-002	Right side panel, S.S.		15-0411-00	Strike
5	03-0271-00	Speed Clip		03-1406-04	Nut
6	15-0808-01	Emblem	12	A34039-001	Control Box Support
7	03-1419-22	Screw	13	A32435-002	Left side panel, S.S.
8	A33255-002	Louvered front panel	14	03-1404-12	Screw
8a	A39048-001	Non-louvered front panel	15	A35924-002	Rear panel, water cooled, SS
9	02-2976-01	Air Filter	16.	A35890-020	Base
	03-1660-01	Filter clip	17	A34348-001	Front Brace, Air Cooled

# NME454, 654 & FME504, 804 SERVICE PARTS

## Air Cooled Refrigeration

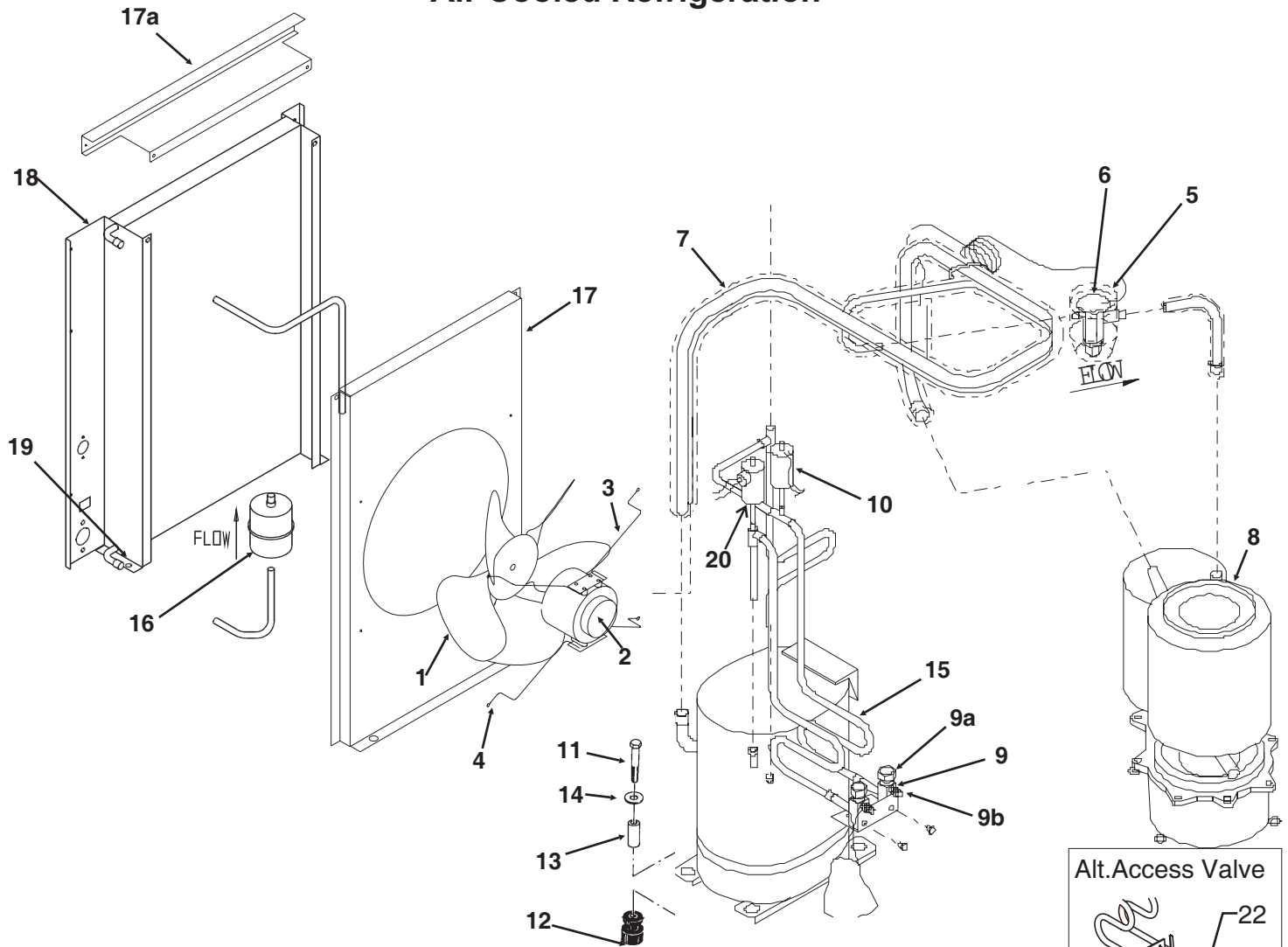

ITEM NUMBER	PART NUMBER	DESCRIPTION
1	18-8747-01	Fan blade
2	18-8736-01	Fan motor, 115v/60 Hz
	18-8736-04	Fan motor, 230v/50 Hz
3	A38850-001	Fan Bracket*
4	03-1531-01	Screw for wire form bracket
	03-1645-01	Screw used after 5/05
5	A32961-020	Insulation Kit (3 piece)
6	11-0488-21	TXV for all but 454, 504
	11-0488-22	TXV for NME454, FME504
7	A35870-001	Suction Line
8	A33194-020	Evaporator - see page 7
9	16-0832-20	Access valve
9a	16-0832-02	Stem cap
9b	16-0832-03	Core cap
10	11-0501-22	Hi Pressure Cut Out
11	03-1645-01	Screw
12	18-2200-28	Grommet
13	18-2200-27	Sleeve

ITEM NUMBER	PART NUMBER	DESCRIPTION
14	03-1407-07	Washer
15	18-8929-21	Compressor, <b>454, 504</b>
	18-8929-23	Overload for the above
<u>Compressors for NME654 or FME804:</u>		
	18-8721-21	Compressor 115v/60 Hz
	18-8711-50	Overload for the above
	18-8721-22	Compressor 230v/50 Hz
	18-8721-50	Overload for 50 the above
16	02-3319-02	Dryer
17	A35886-001	Fan Shroud
17a	A35582-002	Fan shroud cover
18	18-8734-01	Condenser
19	03-1645-01	Screw
20	11-0502-21	Low pressure cut out switch
21	16-1137-01	Access valve body
22	16-1138-01	Core
23	16-1140-01	Cap

\* When replacing a wire formed bracket, use a #8 flat washer with the original mounting screw.

# NME454, 654 & FME504, 804 SERVICE PARTS

## Water Cooled Refrigeration

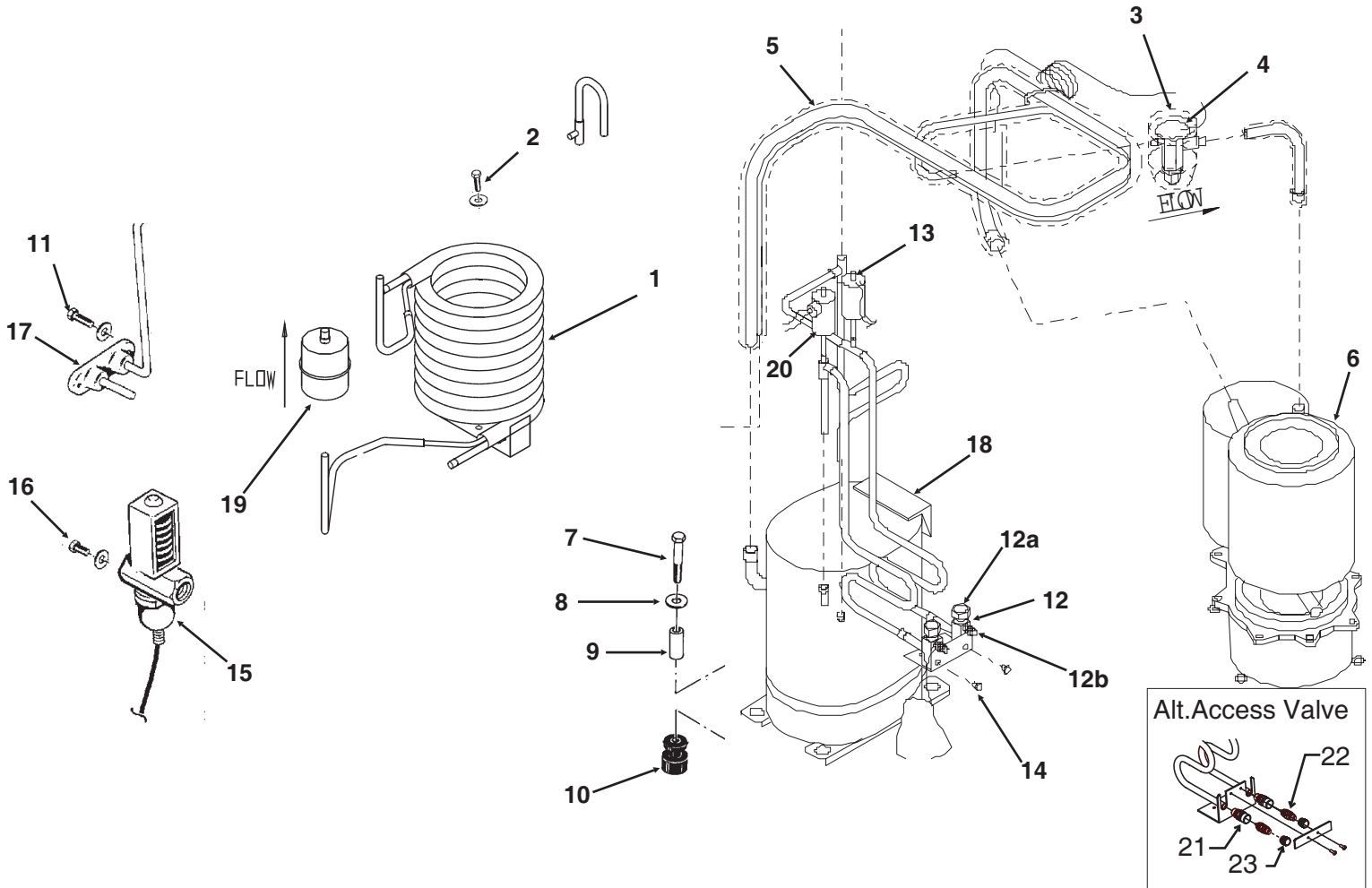

ITEM NUMBER	PART NUMBER	DESCRIPTION	ITEM NUMBER	PART NUMBER	DESCRIPTION
1	18-3306-25	Condenser for A series	13	11-0501-22	Hi Pressure Cut Out
	18-8871-21	Condenser for B series	14	03-0571-02	Screw
2	03-1645-01	Screw	15	11-0478-01	Water Reg. Valve
3	11-0488-21	TXV for all but 454, 504	16	03-1403-14	Screw
	11-0488-22	TXV for NME454, FME504	17	A31878-004	Drain Assembly (WC)
4	A32961-020	Insulation Kit (3 piece)	18	18-8929-21	Compressor, <b>454, 504</b>
5	A35870-001	Suction Line		18-8929-23	Overload for the above
6	A33194-020	Evaporator - see page 7	<u>Compressors for NME654 or FME804:</u>		
7	03-1405-20	Cap Screw		18-8721-21	Compressor 115v/60 Hz
8	03-1407-07	Washer		18-8711-50	Overload for the above
9	18-2200-27	Sleeve		18-8721-22	Compressor 230v/50 Hz
10	18-2200-28	Grommet		18-8721-50	Overload for 50 the above
11	03-1645-01	Screw	19	02-3319-02	Dryer
12	16-0832-20	Access valve	20	11-0502-21	Low pressure cut out switch
12a	16-0832-02	Stem cap	21	16-1137-01	Access valve body
12b	16-0832-03	Core cap	22	16-1138-01	Core
			23	16-1140-01	Cap

# NME454, 654 & FME504, 804 SERVICE PARTS

## Water System

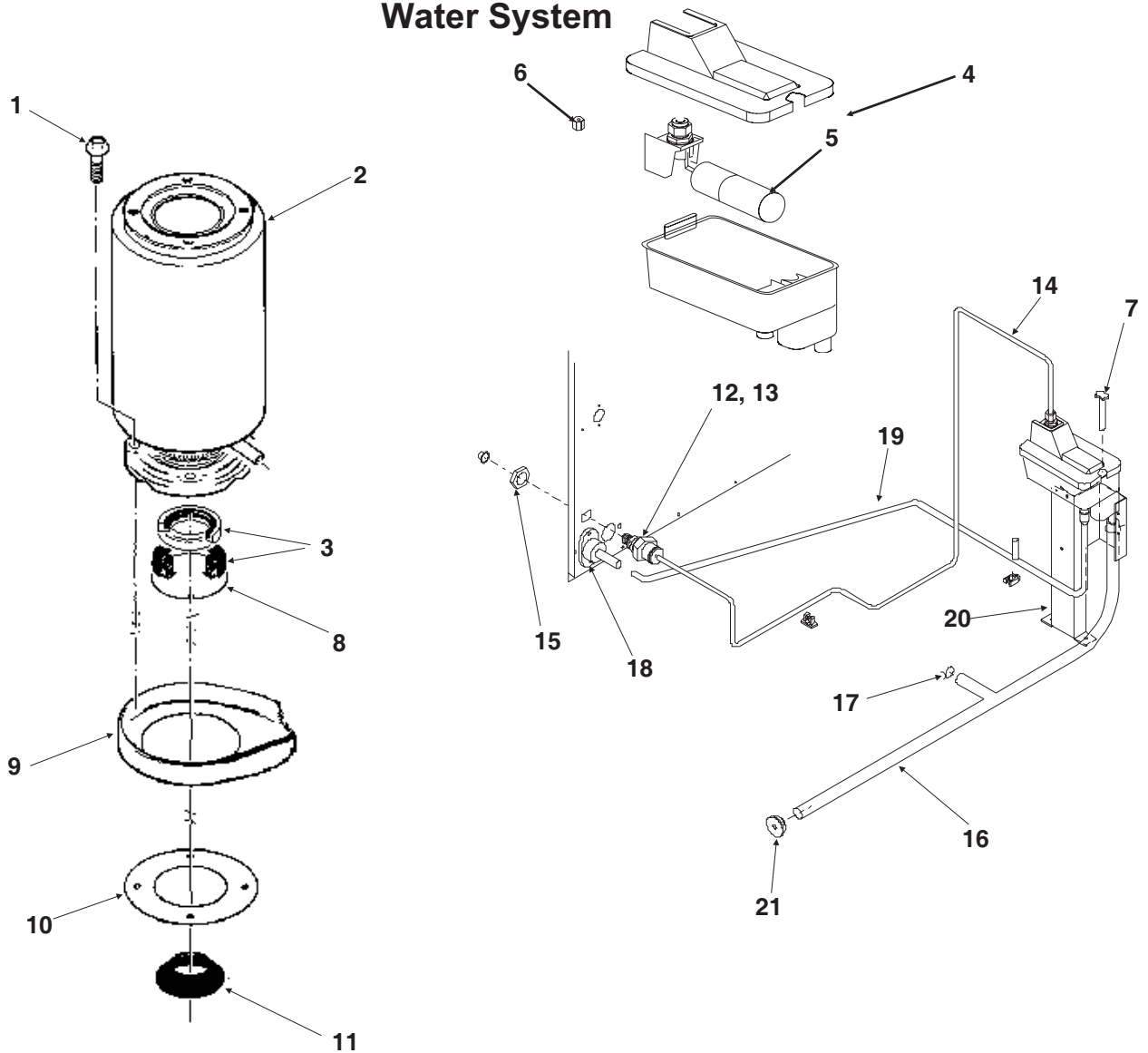

ITEM NUMBER	PART NUMBER	DESCRIPTION
1	03-1405-41	Cap Screw
2	A33194-020	Evaporator
3	02-0929-23	Water Seal
4	02-3266-20	Reservoir & valve
5	02-3266-21	Float valve
6	02-3266-03	Plunger/seat
7	12-2760-21	Water Level Sensor
8	A32777-001	Retaining Ring for Seal
9	02-3837-01	Drip Pan
10	13-0704-00	Gasket
11	13-0868-01	Water Shed
12	16-0835-01	Water Inlet Fitting
13	16-1039-01	Male connector
14	13-0895-01	Inlet tubing, 4 ft. req.

ITEM NUMBER	PART NUMBER	DESCRIPTION
15	03-1394-01	Pal Nut
16	A36154-001	Evap. water inlet tube
17	02-1338-00	Hose clamp
18	02-3692-02	Drain fitting
19	02-3826-03	Res. overflow hose
20	A36078-002	Reservoir bracket
21	13-0840-01	Rubber cap

# NMF454 654 & FMF504 804 SERVICE PARTS

## Gearmotor

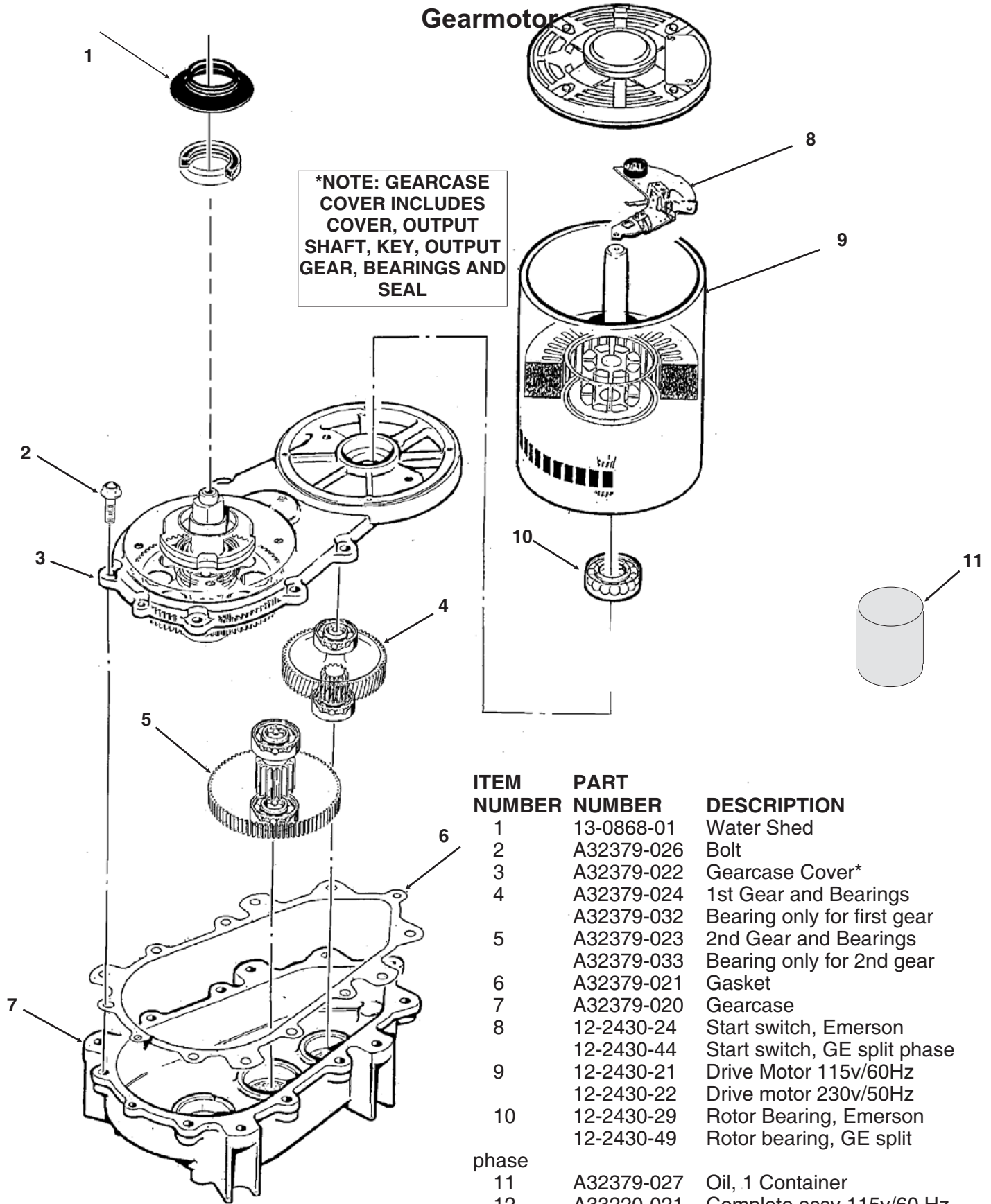

ITEM NUMBER	PART NUMBER	DESCRIPTION
1	13-0868-01	Water Shed
2	A32379-026	Bolt
3	A32379-022	Gearcase Cover*
4	A32379-024	1st Gear and Bearings
	A32379-032	Bearing only for first gear
5	A32379-023	2nd Gear and Bearings
	A32379-033	Bearing only for 2nd gear
6	A32379-021	Gasket
7	A32379-020	Gearcase
8	12-2430-24	Start switch, Emerson
	12-2430-44	Start switch, GE split phase
9	12-2430-21	Drive Motor 115v/60Hz
	12-2430-22	Drive motor 230v/50Hz
10	12-2430-29	Rotor Bearing, Emerson
	12-2430-49	Rotor bearing, GE split phase
11	A32379-027	Oil, 1 Container
12	A33220-021	Complete assy 115v/60 Hz
	A33220-022	Complete assy, 230v/50 Hz

The complete assembly includes the water shed and drip pan gasket.



# NME454, 654 & FME504, 804 SERVICE PARTS

## FME504 or FME804 Evaporator

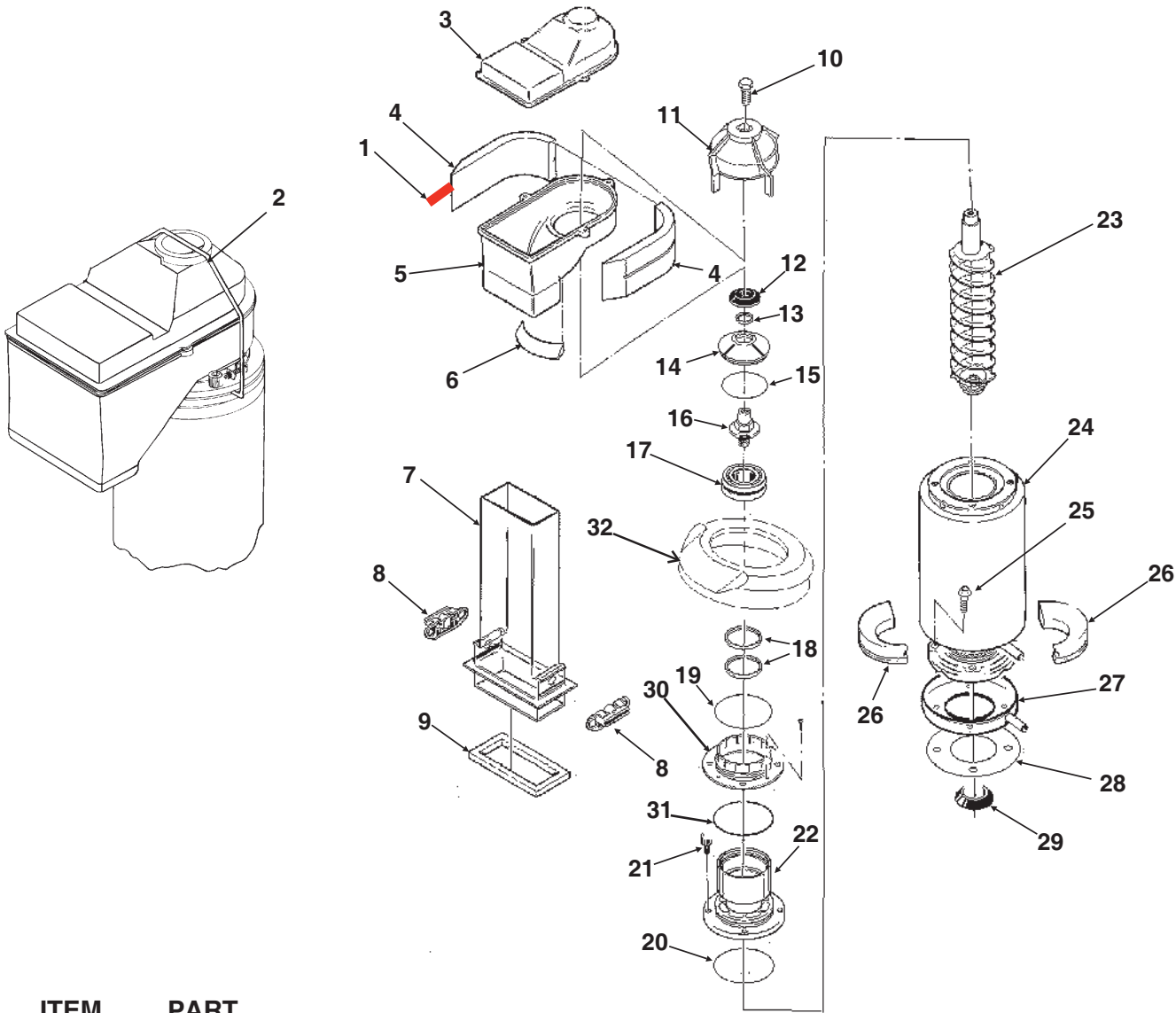

ITEM NUMBER	PART NUMBER	DESCRIPTION
1.	A35419-020	Strap kit*
2.	A34969-001	Bail clamp
3.	02-2930-04	Ice Chute Cover
4.	A32963-001	Insulation Top (half)*
5.	02-3841-01	Ice Chute Body w/ins*
6.	A33102-001	Insulation Collar Inside*
7.	02-2929-03	Ice Chute Lower
8.	A37708-021	Bin Controls Assy. (set of 2)
9.	A32930-001	Chute Gasket
10.	03-1405-52	Hex Cap Screw
11.	02-3001-01	Ice Sweep
12.	13-0871-01	Water Shed
13.	02-2978-01	Lip Seal
14.	02-3128-20	Breaker Cover
15.	13-0617-54	O-Ring
16.	08-0660-01	Auger Stud
17.	A34559-020	Bearing
18.	02-2977-01	Lip Seal
19.	13-0617-52	O-Ring
20.	13-0617-45	O-Ring
21.	03-1544-08	Soc. Head Screw
22.	A34505-020	Breaker (includes 13,14,15,17,18, 20)
23.	A38071-021	Auger
24.	A33194-020	Evaporator
25.	03-1405-41	Cap Screw
26.	A32962-001	Insulation Bot. (half)
	A32962-002	Insulation half
27.	02-3837-01	Drip Pan
28.	13-0704-00	Drip Pan Gasket
29.	13-0868-01	Water Shed
30.	02-2916-01	Slotted collar
31.	13-0617-49	O-Ring
32.	13-0929-01	Insulation donut*

\* Insulation changed Oct. 2000. Items 1, 4 and 6 no longer used. Item 32 added. Item 5 changed.

# NME454, 654 & FME504, 804 SERVICE PARTS

## NME454 or NME654 Evaporator

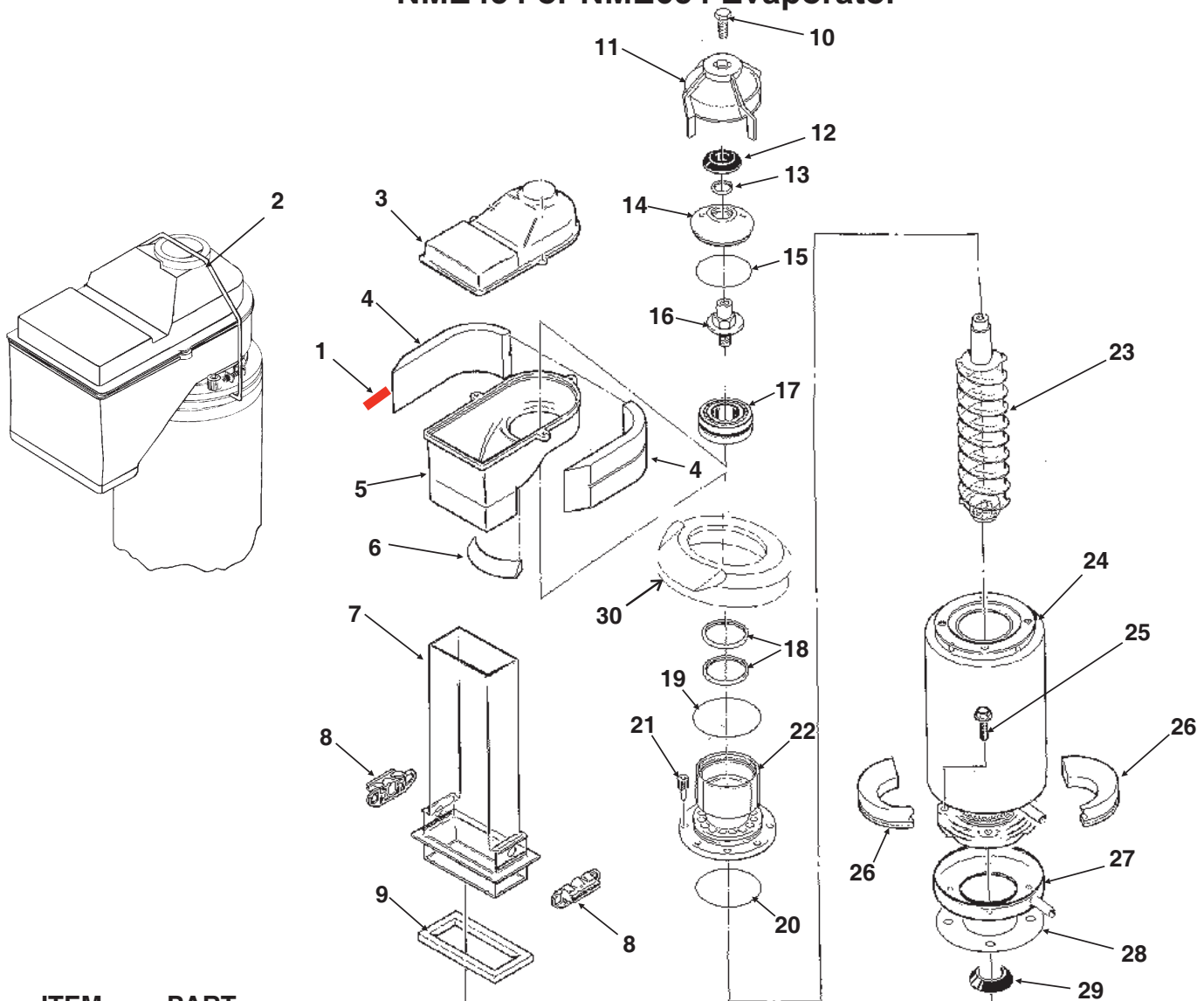

ITEM NUMBER	PART NUMBER	DESCRIPTION
1.	A35419-020	Strap kit*
2.	A34969-001	Bail clamp
3.	02-2930-04	Ice Chute Cover
4.	A32963-001	Insulation Top (half)*
5.	02-3841-01	Ice Chute Body*
6.	A33102-001	Insulation Collar Inside*
7.	02-2929-03	Ice Chute Lower
8.	A37708-021	Bin Controls Assy. (set of 2)
9.	A32930-001	Chute Gasket
10.	03-1405-52	Hex Cap Screw
11.	02-3001-01	Ice Sweep
12.	13-0871-01	Water Shed
13.	02-2978-01	Lip Seal
14.	02-3128-20	Breaker Cover
15.	13-0617-54	O-Ring
16.	08-0660-01	Auger Stud
17.	A34559-020	Bearing
18.	02-2977-01	Lip Seal
19.	13-0617-52	O-Ring
20.	13-0617-45	O-Ring
21.	03-1544-08	Soc. Head Screw
22.	A32900-020	Breaker (includes 13, 14, 15, 17, 18 & 20)
23.	A38071-021	Auger
24.	A33194-020	Evaporator
25.	03-1405-41	Cap Screw
26.	A32962-001	Insulation Bot. (half)
	A32962-002	Insulation half
27.	02-3837-01	Drip Pan
28.	13-0704-00	Drip Pan Gasket
29.	13-0868-01	Water Shed
30.	13-0929-02	Insulation donut*

\* Insulation changed Oct. 2000. Items 1, 4 and 6 no longer used. Item 30 added. Item 5 changed.



# NME454, 654 & FME504, 804 SERVICE PARTS

## Control Box

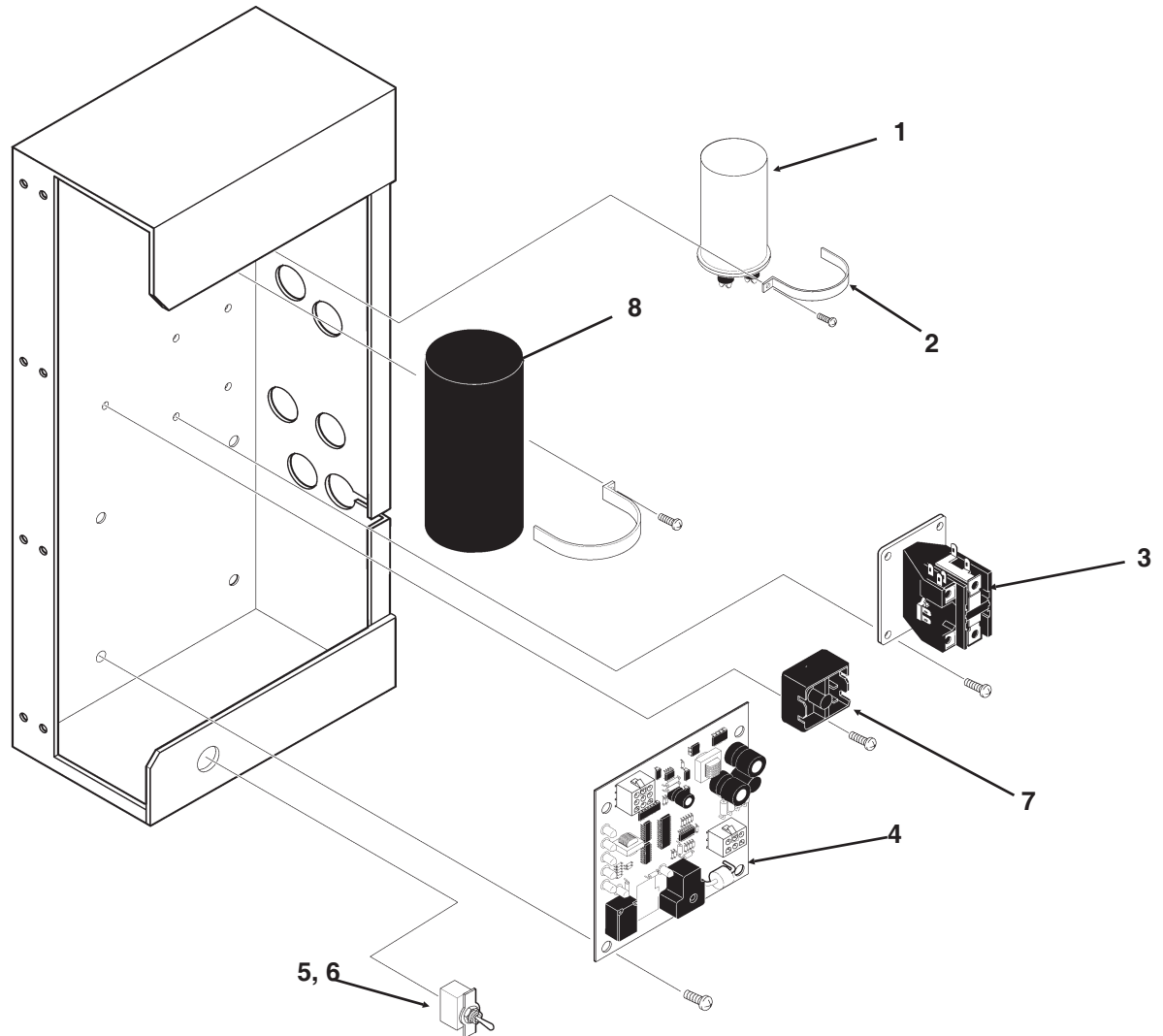

	FME504, NME454 115 Volt, 60 Hz	FME804, NME654, 115 Volt, 60 Hz	FME804, NME654, 230 Volt, 50 Hz
Start Capacitor	18-1901-63	18-1901-03	18-1901-43
Contactor	12-2469-03	12-2469-03	12-2469-02
Circuit Board	12-2835-21	12-2835-21	12-2835-21
Mode Switch	12-0426-01	12-0426-01	12-2637-01
Potential Relay	18-1903-64	18-1903-50	18-1903-56
Run Capacitor	none	18-1902-45	18-1902-30

# NME454, 654 & FME504, 804 SERVICE PARTS

## NME654, FME804 Component Layout Diagram

17-2703-01

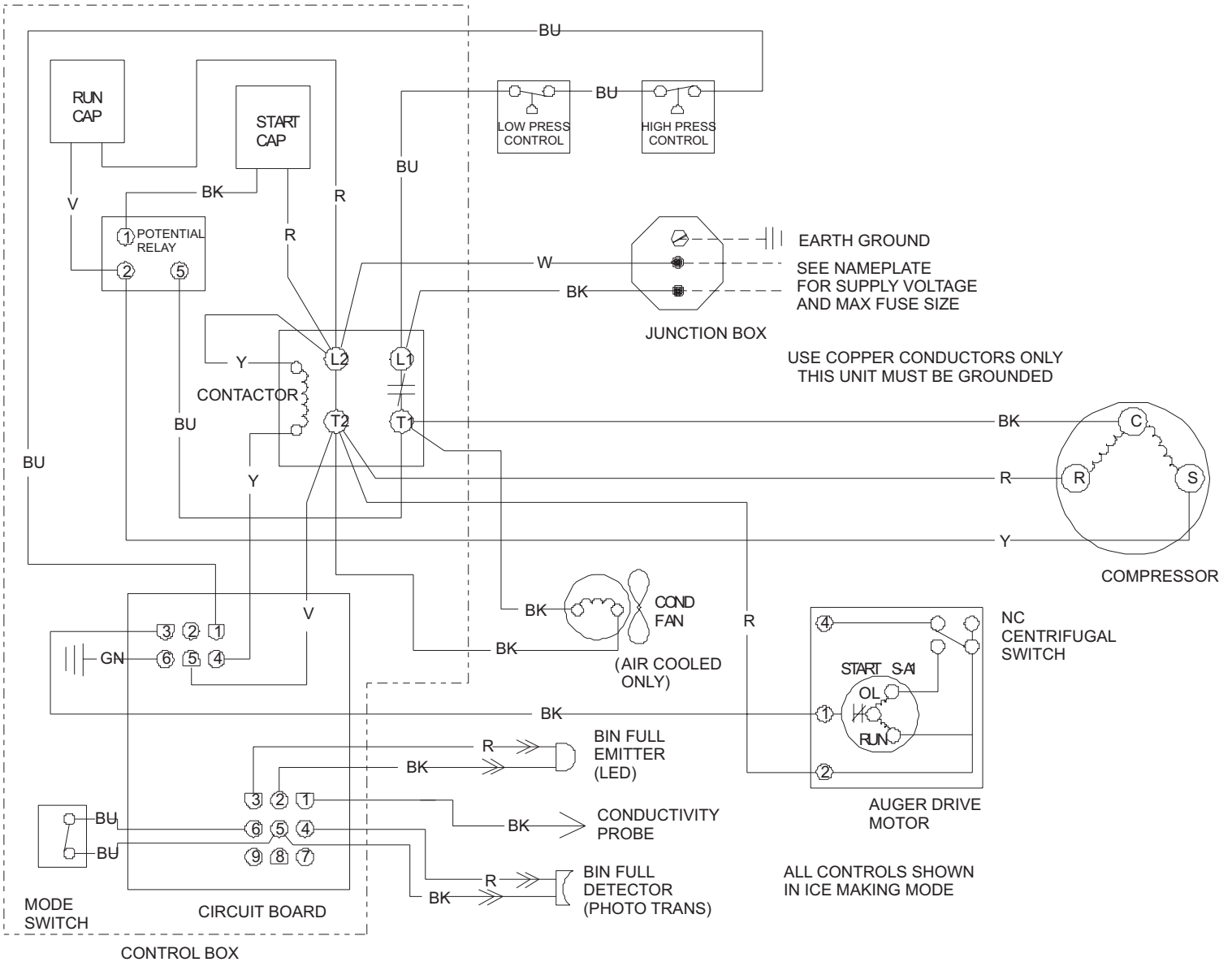

# NME454, 654 & FME504, 804 SERVICE PARTS NME654, FME804 Schematic Diagram

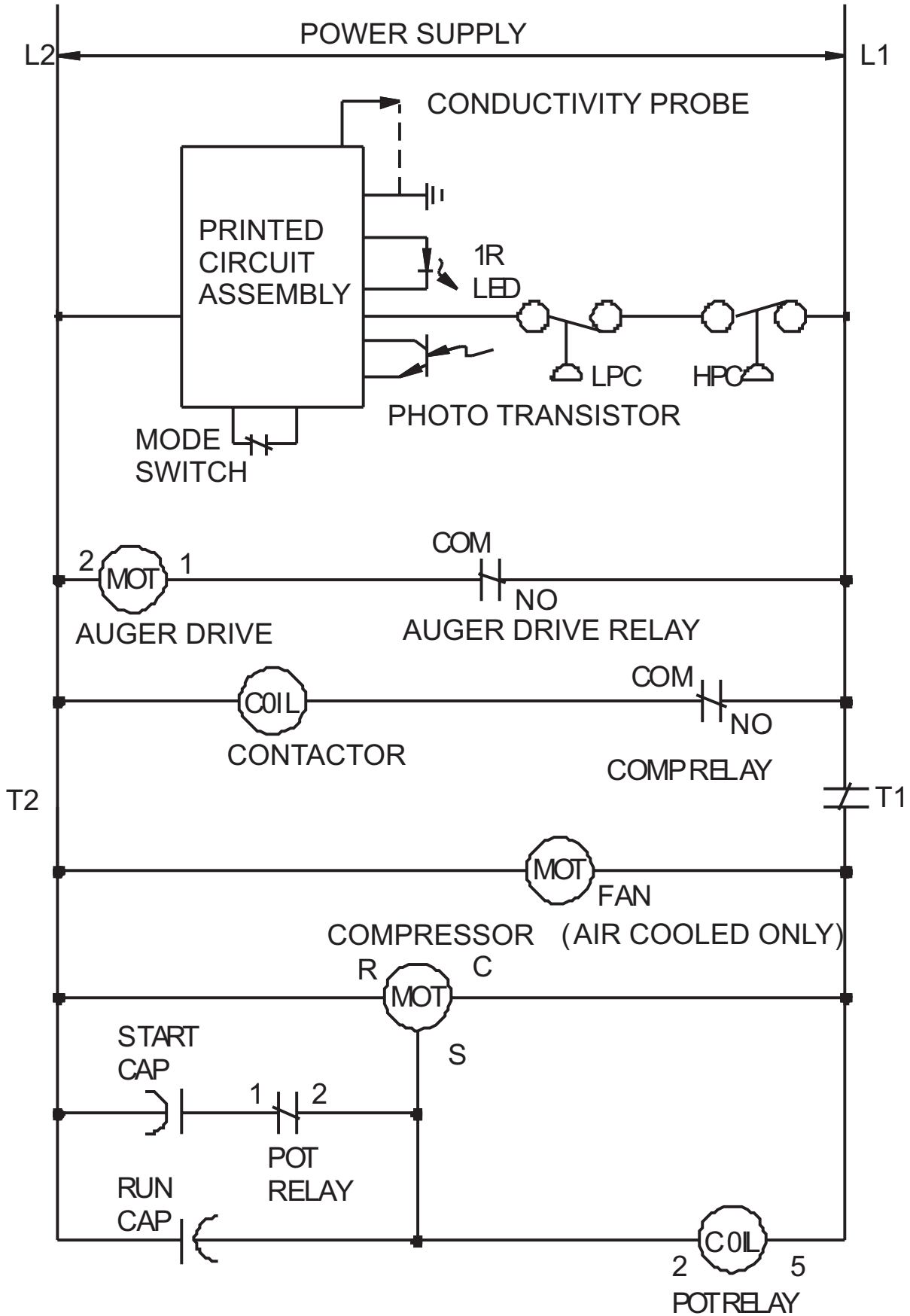

# NME454, 654 & FME504, 804 SERVICE PARTS

## NME654 or FME804 -6

17-2702-01

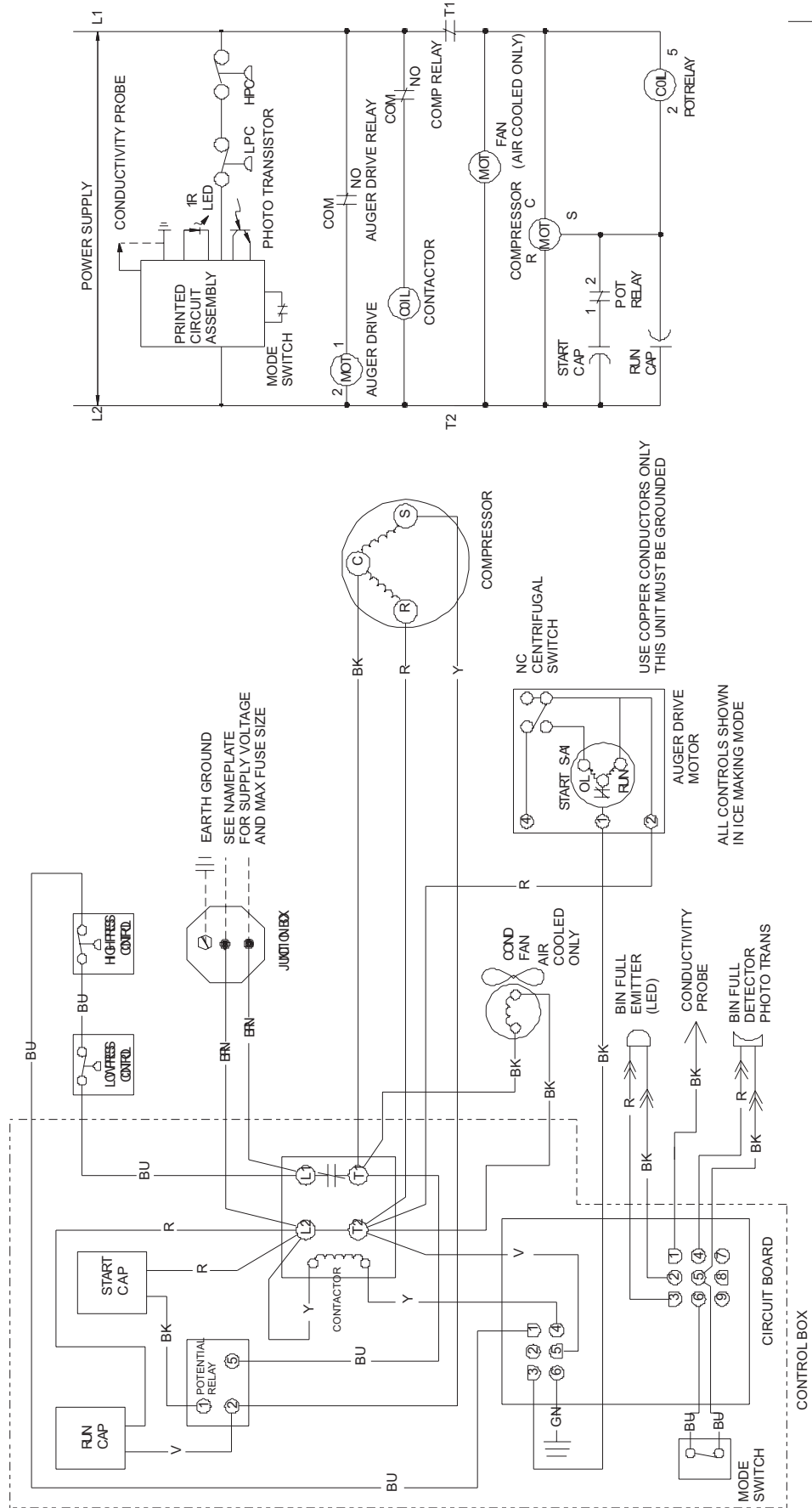

# NME454, 654 & FME504, 804 SERVICE PARTS

## NME454 Wiring Diagram

17-3172-01

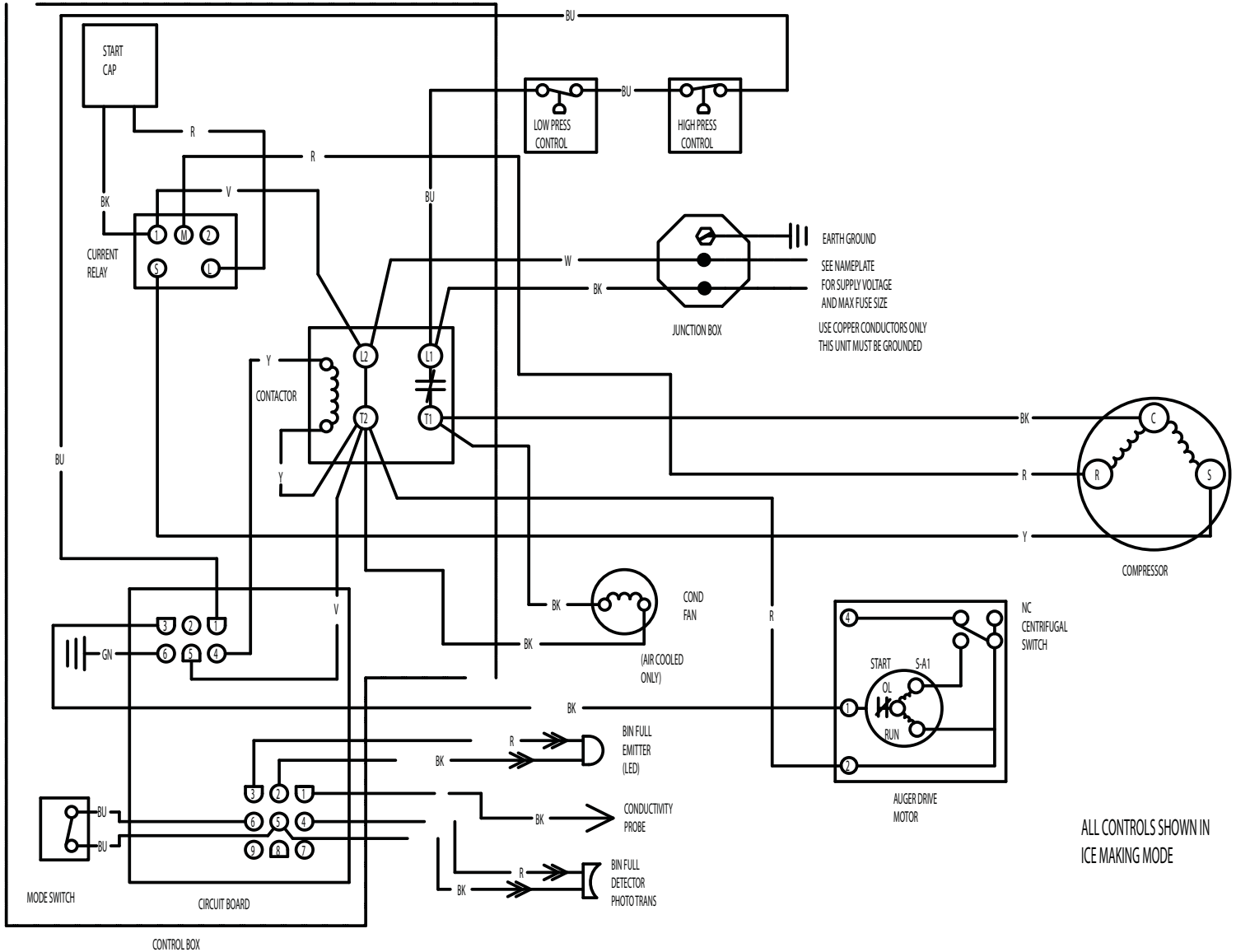

# NME454, 654 & FME504, 804 SERVICE PARTS

## NME454 Schematic Diagram

