

IF IN DOUBT ASK!!

DO NOT SCALE !!  
First Angle Projection

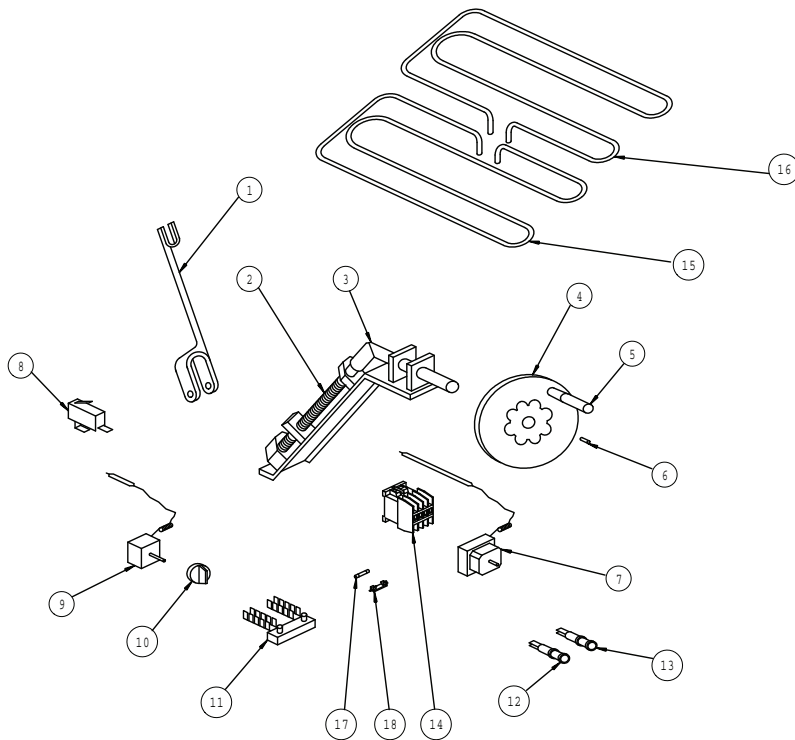
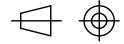

ITEM	DESCRIPTION	E2962 SPARES No.	E2994 SPARES No.
1	JACK ARM	531750430	531750430
2	SCREW JACK	531750440	531750440
3	UNIVERSAL COUPLING	531790350	531790350
4	HANDWHEEL ASSY	531750510	531750510
5	FOLDING HANDLE	531750511	531750511
6	LOCKING PIN	531750512	531750512
7	SAFETY THERMOSTAT	531750502	531750502
8	MICROSWITCH	531750540	531750540
9	CONTROL THERMOSTAT	731750711	731750711
10	CONTROL THERMOSTAT KNOB	537810070	537810070
11	TERMINAL BLOCK	537810110	537810110
12	INDICATOR LAMP-AMBER	537810050	537810050
13	INDICATOR LAMP-RED	537810060	537810060
14	CONTACTOR	731750860	731750860
15	ELEMENT LH	731750420	731750420
	ELEMENT CENTRE	-----	731750420
16	ELEMENT RH	731750421	731750421
17	FUSE 2A	731881060	731881060
18	FUSE HOLDER	731881070	731881070

All dimensions in millimetres, Tolerance- Linear  $\pm 0.5\text{mm}$  Angular  $\pm 0.5^\circ$  (or as stated). All sharp edges to be removed from sheet metal parts.

B		CONTROL THERMOSTAT WAS 537810100	I. HAMILTON	15-01-09
A		1012 ISSUED FOR PRODUCTION	I. HAMILTON	19-05-04
Issue	Mod No.	Alteration	Zone	Drawn by



Drawn	I. HAMILTON	Product	E2962/94 BRATT PANS	
Date	18-05-04	Title	SPARES DIAGRAM-CONTROLS & ELECTRICS	
Scale	N. T. S.		Drawing Number	Issue
Matl.			AF42640	B
No. off		Finish		
Bin No.		Kraus No.	T111448	

No reproduction or publication of this drawing may be made and no article may be manufactured or assembled in accordance with this drawing without prior written consent. This prohibition is a term of any contract relating to this drawing. Rights reserved under the Copyright Act 1956 as amended by the Design Copyright Act 1968.

This part is common to the following units

Falcon Foodservice Equipment. Wallace View Hillfoots Road Stirling Scotland

IF IN DOUBT ASK!!

DO NOT SCALE !!

First Angle Projection

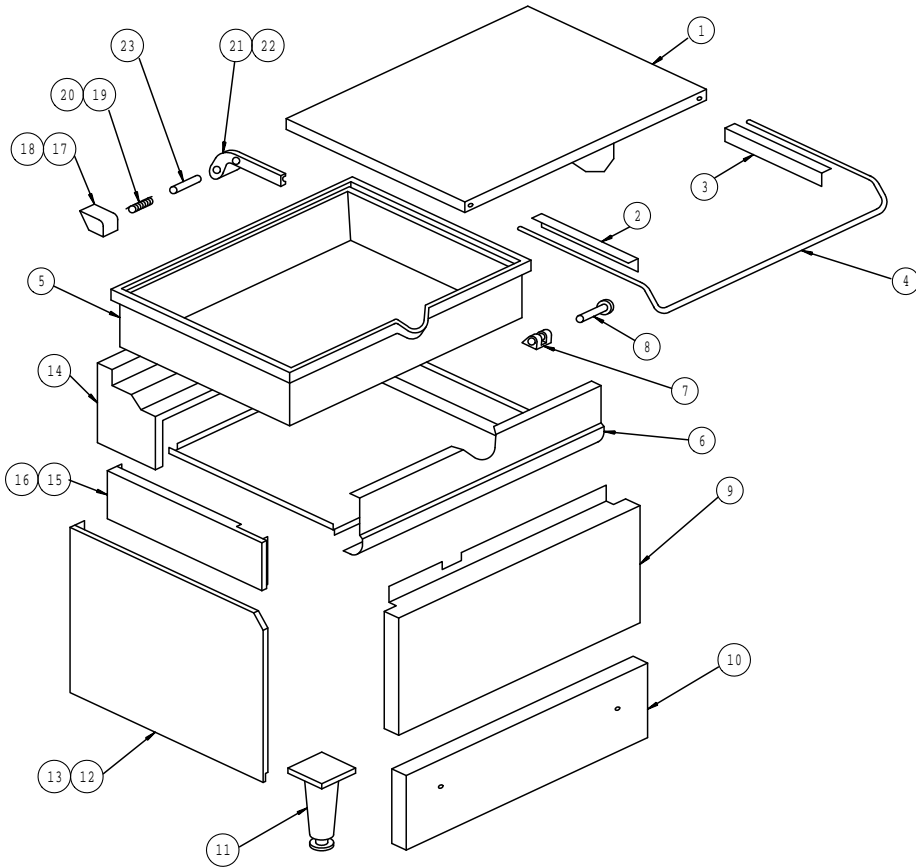
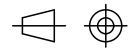

ITEM	DESCRIPTION	E2962 SPARES No.	E2965 SPARES No.	E2994 SPARES No.	E2995 SPARES No.
1	PAN LID	531750010	531750010	531790010	531790010
2	LID HANDLE BRACKET L.H.	531750020	531750020	531750020	531750020
3	LID HANDLE BRACKET R.H.	531750030	531750030	531750030	531750030
4	LID HANDLE	531750040	531750040	531790020	531790020
5	PAN	731750010	731750010	731750020	731750020
6	PAN FACIA PANEL	537810030	537810030	537830010	537830010
7	PAN HINGE CASTING	531750070	531750070	531750070	531750070
8	PAN HINGE PIN	531750080	531750080	531750080	531750080
9	FRONT PANEL PRE F480123	537810080	537820010	537830020	537840010
9	FRONT PANEL POST F480123	537810085	537820015	537830025	537840015
10	BOTTOM FRONT PANEL PRE F480123	537810040	537810040	537830060	537830060
10	BOTTOM FRONT PANEL POST F480123	537810045	537810045	537830065	537830065
11	ADJUSTABLE LEG	531750110	531750110	531750110	531750110
12	OUTER SIDE PANEL L.H.	531750120	531750120	531750120	531750120
13	OUTER SIDE PANEL R.H.	531750130	531750130	531750130	531750130
14	REAR HOB RAIL	537810090	537810090	537830030	537830030
15	PAN SIDE PANEL L.H.	537810010	537810010	537810010	537810010
16	PAN SIDE PANEL R.H.	537810020	537810020	537810020	537810020
17	LID HINGE BLOCK L.H.	531750180	531750180	531750180	531750180
18	LID HINGE BLOCK R.H.	531750560	531750560	531750560	531750560
19	LID HINGE SPRING L.H.	531750190	531750190	531750190	531750190
20	LID HINGE SPRING R.H.	531750200	531750200	531750200	531750200
21	LID HINGE ARM L.H.	531750210	531750210	531750210	531750210
22	LID HINGE ARM R.H.	531750220	531750220	531750220	531750220
23	LID HINGE BAR	531750240	531750240	531750240	531750240
24	CENTRE TRAY	731750901	731750890	731750880	731750900

All dimensions in millimetres, Tolerance- Linear  $\pm 0.5\text{mm}$  Angular  $\pm 0.5^\circ$  (or as stated). All sharp edges to be removed from sheet metal parts.

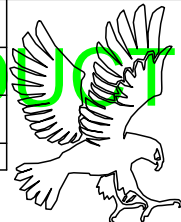

**CLEARED FOR PRODUCTION**

B	6162	ITEMS 9 & 10 UPDATED	F GARVOCK	19/03/10		
A	1012	ISSUED FOR PRODUCTION	I. HAMILTON	19-05-04		
G	Issue	Mod No.	Alteration	Zone	Drawn by	Date

Drawn	I. HAMILTON	Product	E2962/5/94/5 BRATT PANS	
Date	19-05-04	Title	SPARES DIAGRAM - FITMENTS	
Scale	N.T.S.	Matl.	Drawing Number	Issue
No. off		Finish	AF42639	B
Bin No.	rnd16	Kraus No.		

No reproduction or publication of this drawing may be made and no article may be manufactured or assembled in accordance with this drawing without prior written consent. This prohibition is a term of any contract relating to this drawing. Rights reserved under the Copyright Act 1956 as amended by the Design Copyright Act 1968.

This part is common to the following units