

ROBOT

ROBOT LINE

TYPE: RO

Accessories
WITHOUT ACCESSORY

Spare Parts Manual

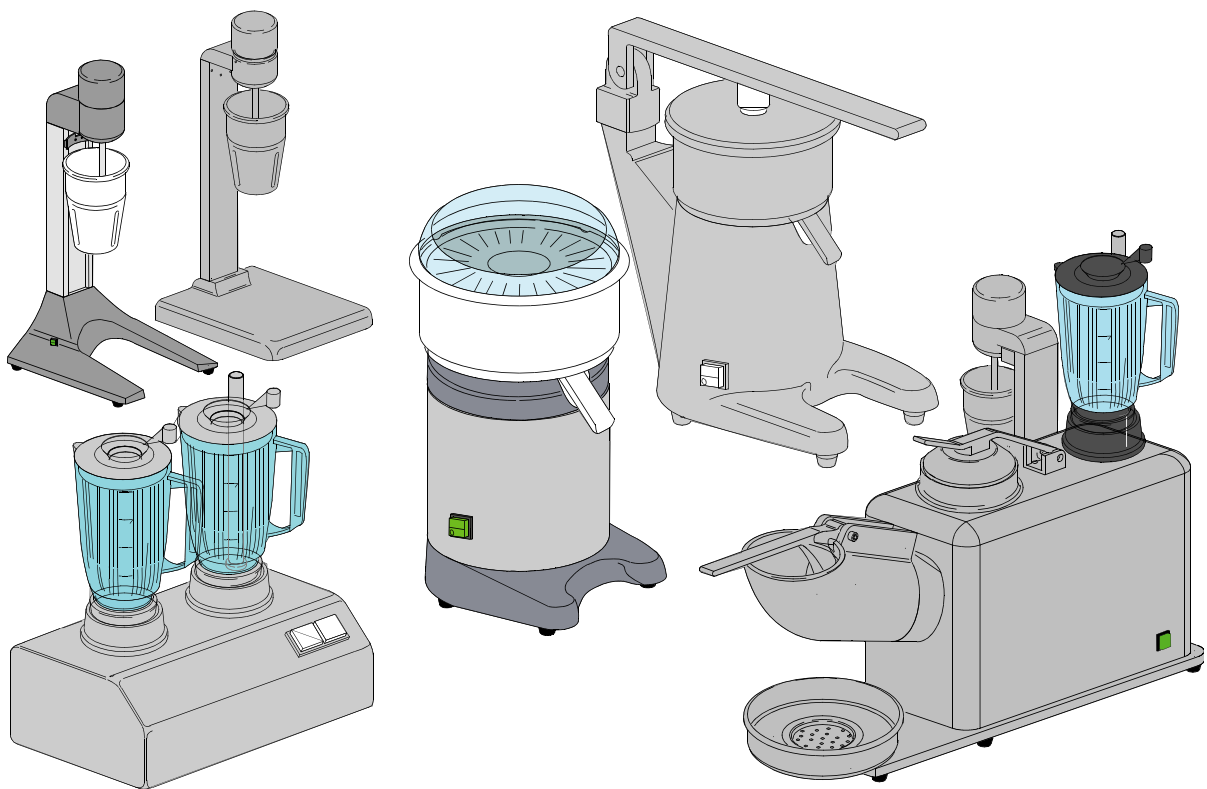

INFORMAZIONI GENERALI

Questo catalogo serve per richiedere con esattezza le parti di ricambio

Nelle ordinazioni indicare:

1) il numero dei codici dei particolari seguito dalla descrizione e la quantità desiderata;

2) Il codice alfa-numerico presente nella seconda colonna della tabella ;

I disegni delle parti di ricambio sono solo indicativi e non rappresentano il pezzo in oggetto.

I dati contenuti in questo catalogo sono indicativi e possono essere soggetti a modifiche senza impegno di preavviso.

ALLGEMEINE INFORMATIONEN

Dieser Ersatzteilkatalog dient zur genauen Angabe der Teile bei Ersatzteilbestellungen.

Bei Ersatzbestellung ist folgendes anzugeben:

1) Die Bestellnummer der Ersatzteile mit der entsprechenden Beschreibung genaue Menge;

2) Der alpha-numerischer Code auf der zweiten Reihe in dein Spclud;

Die Zeichnungen der Ersatzteile sind nur als Hinweise gedacht und stellen nicht das betroffene Teil dar.

Bei den im Katalog angeführten Daten handelt es sich um Anhaltsdaten, die jederzeit, ohne Vorankündigung, geändert werden können.

GENERAL INFORMATION

The present spare parts order exactly the right spare parts

When ordering specify:

1) the part's code number followed by its description and quantity needed;

2) The alpha-numeric code is in the second column in the chart;

Spare parts drawings are general and do not represent the part.

The contents of this catalogue are general and can undergo changes without prior notice.

INFORMACIONES GENERALES

El presente catálogo sirve para pedir con exactitud las partes de repuesto

En los pedidos se debe indicar:

1) el número de código de la parte y a continuación la descripción cantidad deseada;

2) El código alfanumerico presente en la segnada columna de la tabla;

Los diseños de las partes de recambio son solo indicativos y no representan la pieza en cuestión.

Los datos contenidos en el presente catálogo son indicativos y pueden modificarse sin aviso previo.

INFORMATIONS GENERALES

Ce catalogue permet de commander correctement les pièces détachées

Les commandes doivent être passées en indiquant:

1) le numero de code des pièces détachées suivi de leur description quantité désirée;

2) le code alphanumérique dans la deuxième colonne du tableau;

Les plans des pièces détachées sont fournis seulement à titre indicatif et ne représentent pas la pièce concernée.

Les données de ce catalogue sont citées seulement à titre indicatif et peuvent être l'objet de modifications sans avis préalable.

ESEMPIO
EXAMPLE
EXEMPLE
BEISPIEL

Rif.	Codici
MODULE:Particolari	
10505	540903
10510	540908
10515	15065/A
10520	540086
10525	540028



Note

Tutte le informazioni riportate si intendono aggiornate alla data di stampa. Il Produttore si riserva il diritto di apportare qualsiasi modifica richiesta dallo sviluppo evolutivo dei suddetti prodotti.

Per la sicurezza, la garanzia, l'affidabilità ed il valore della lavastoviglie usa solo ricambi originali. **Per alcuni codici, sono richieste quantità minime d'ordine.**



Attenzione

Questo libretto è parte integrante della lavastoviglie e, in caso di passaggio di proprietà, deve essere consegnato al nuovo acquirente.



Remarque

Toutes les informations contenues dans ce manuel s'entendent mises à jour à la date d'impression. En raison du développement constant de ses produits, usine se réserve le droit d'apporter à tout instant les modifications qu'elle jugera utiles.

Pour la sécurité, la garantie, la fiabilité et la valeur de votre lavevaisselles n'utilisez que des pièces de rechange d'origine. **Pour quelque référence on demande un minimum de pièces par commande**



Attention

Ce manuel doit être considéré comme partie intégrante de la la lavevaisselles, en cas de transfert de propriété, doit toujours être remis au nouveau propriétaire.



Note

The information contained herein is valid at the time of going to print. The Company reserves the right to make any changes required by the future development of the above-mentioned products.

For your safety, as well as to preserve the warranty reliability and worth of your dishwashers, use original spare parts only. **For some codes a minimum quantity for order is required.**



Warning

This manual forms an integral part of the dishwashers and - if a transfer of title occurs - must always be handed over to the new owner.



Hinweis

Die Der Hersteller behält sich das Recht vor, jegliche, durch eine Weiterentwicklung der genannten Produkte bedingte Änderungen vornehmen zu können.

Verwenden Sie für Ihre Sicherheit, die Garantie, die Zuverlässigkeit und den Wert Ihrer machine originale Ersatzteile. **Für bestimmte Code nummer werden mindesten bestellungen verlangt.**



Achtung

Diese Betriebsanleitung ist Bestandteile des machine und muss bei seinem Weiterverkauf dem neuen Besitzer ausgehändigt werden.



Code DW 999XXXXXX
Model DESCRIPTION
S/N DW A 1015770 Type

400V 3N 50HZ 8A
3500W 500W

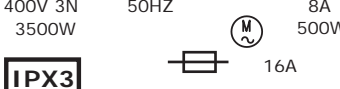

IPX3 16A

Pressione Dinamica alimentazione idrica 200-500 kPa
 Pression dynamique arrivée d'eau
 Dynamic pressure water supply
 Dynamischer Druck asserreinlauf

Pressione dinamica vapore saturo
 Pression dynamique vapeur satueèè
 Dymanischer Druck gesattigter Dampf
 Pression Dinamica Vapor Saturado

CL/Part

(N)

TECHICAL SPECIFICATION

MADE IN ITALY

Temperatura massima acqua in ingresso 60°C
 Temperature max eau a l'entre
 Maximale Temperatur Wasseranschlu
 Maximum Water temperature in-feeding

Model 

S/N 

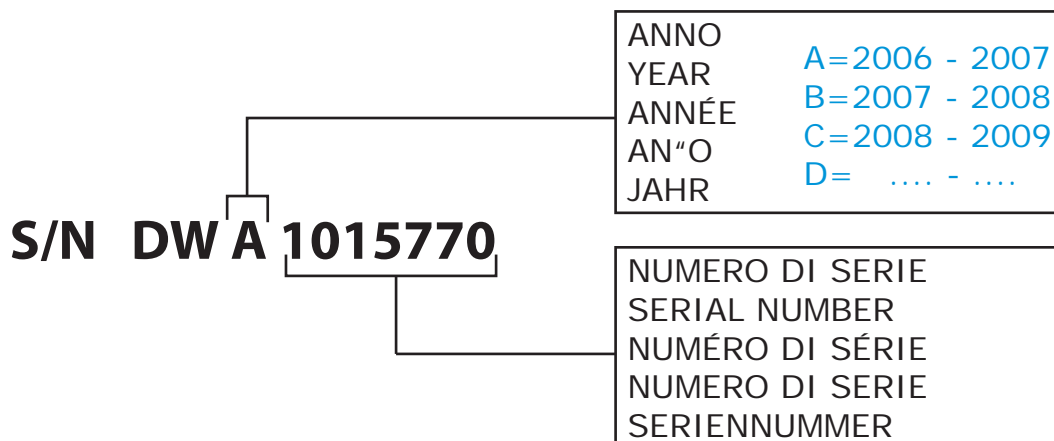
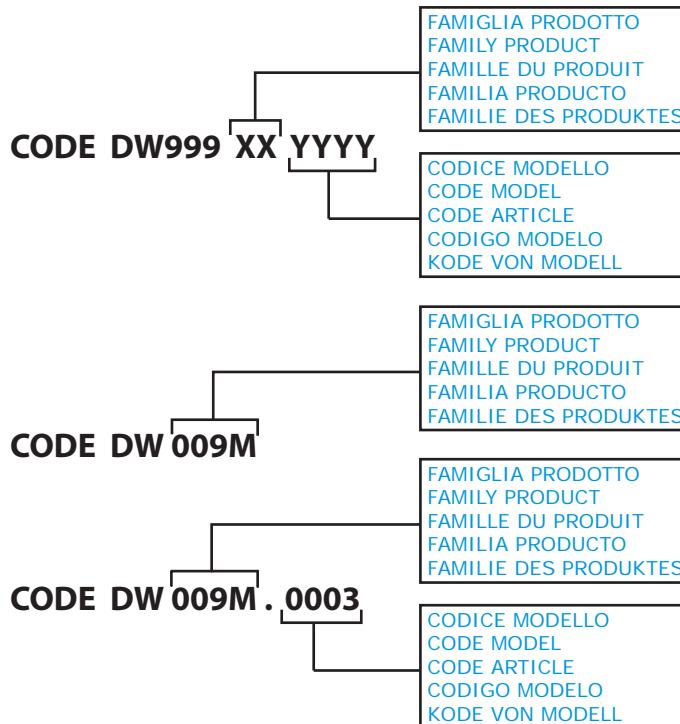

1. Spare parts

Blender F1 / F2 (KF-1 / KF-2).....	7
Blender F1 / F2 (KF-1 / KF-2).....	11
Blender F1 / F2 (KF-1 / KF-2 / KF-1 INOX)13	
Citrus squeezers S30 (BK-3).....	17
Citrus squeezers S40 (BK-4).....	19
Citrus squeezers S40 (BK-4).....	21
Citrus squeezers S55 (BK-5).....	23
Citrus squeezers S55 (BK-5).....	25
Ice-cracker SG2 (BK-91) m.y 2007 ...	27
Ice-cracker SG2 (BK-91)m.y 2008....	29
Multiple group GM mod.03 (BK-10)	31
Multiple group GM/2 mod.03 (BK-11)	33
Multiple group GM - GM/2 (BK-11)	37
Multiple group GM2/2	41
Multiple group GM2/2 mod.03	45
Multiple group GM3 mod.03 (BK-12)	49

Multiple group GM4 mod.03 (BK-13)53

Multiple group GM3 - GM4.....57

Mixer M1 - M2 - MP (BK1 - BK2 - BKP)63

Mixer M1 - M2 - MP (BK1 - BK2 - BKP)65

Mixer M1 - M2 - MP (BK1 - BK2 - BKP)67

Mixer M1 - M2 - MP (BK1 - BK2 - BKP) my 200769

1.1 Voltage codes

Volt	Voltage code
A	3/N/PE~380-400V 50-60Hz
D	3/PE~200-210V 50-60Hz
F	2/PE~220-240V 50-60Hz
G	3/N/PE~415V 50-60Hz
H	3/PE~220-230V 50-60Hz
K	3/PE~380-400V 50-60Hz
L	3/PE~415V 50-60Hz
M	3/PE~440V 60Hz
P	1/N/PE~220-230V 50-60Hz
R	2/PE~220-240V 50-60Hz
U	1/N/PE~240V 50-60Hz
V	3/PE~240V 50-60Hz
W	1/N/PE~100-110V 50-60Hz

1.2 Product codes

Product code	Full name
Model codes	
ro	ROBOT LINE
Type codes	
RO	RO
Accessory codes	
wa	WITHOUT ACCESSORY

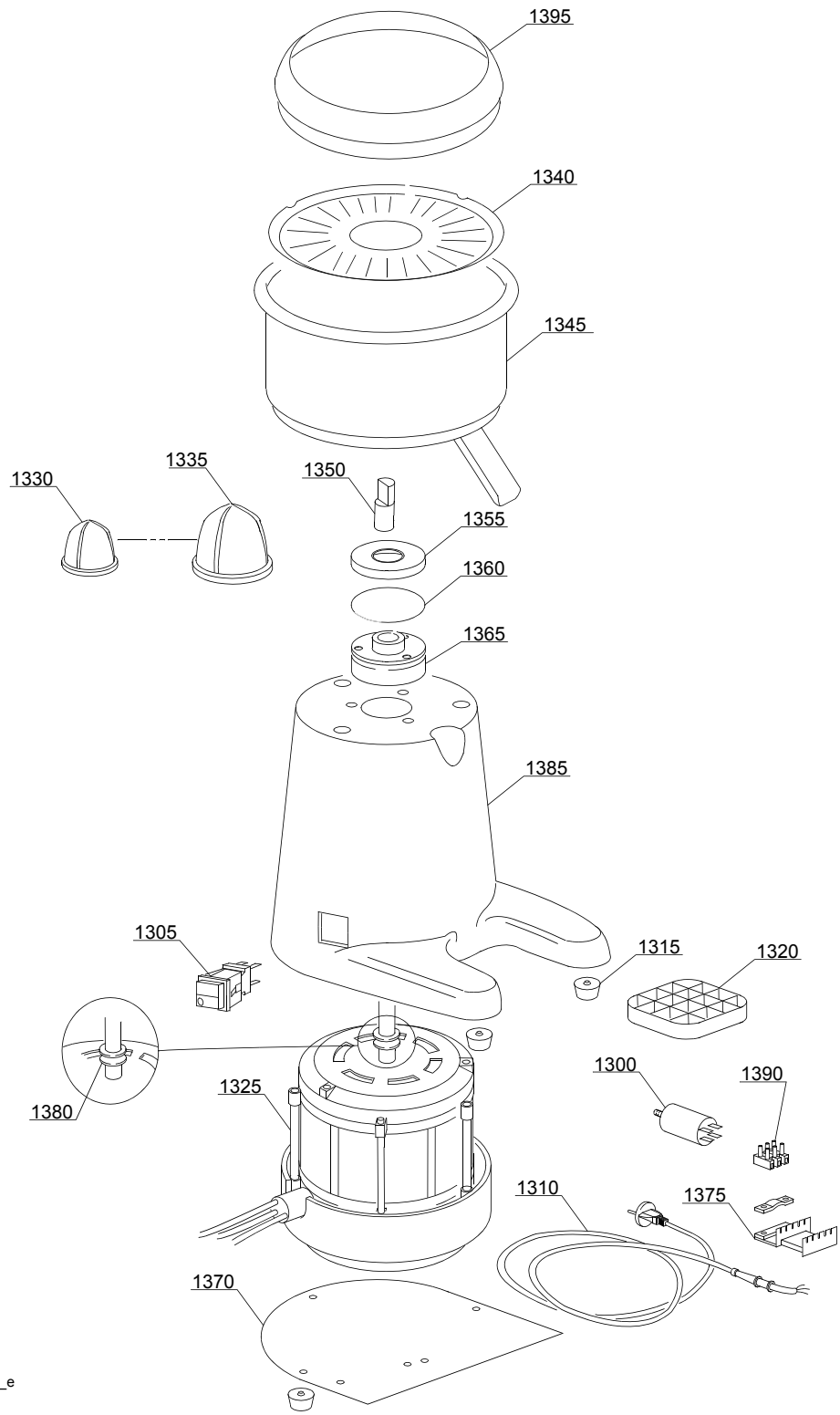

01_009_e

Spare parts

ID	P-code	SN from	SN to	Mod.	Acces.	Volt	Description
Module: Citrus squeezers S40 (BK-4)							
1300	10702		-				5uF condenser
1305	15861		-				0-1 green single key switch
1310	16154		-				Power supply cable
1315	60126		-				Rubber small foot
1320	60138		-				Glasses holder
1325	60370		-				Engine
1330	60371		-				Small cone
1335	60372		-				Big cone
1340	60373		-				Stainless steel sieve
1345	60374		-				Stainless steel small basin
1350	60375		-				Cone shaft
1355	60376		-				Support cover
1360	60377		-				OR gasket 18,64x3,53
1365	60378		-				Container support
1370	60524		-				Bottom protection
1375	60525		-				Cable holder
1380	60532		-				V-ring
1385	60600		-				Aluminium body
1390	60610		-				Terminal board
1395	60611		-				Top protection ring

ro=ROBOT LINE

RO=RO

wa= WITHOUT ACCESSORY

A=3/N/PE~380-400V 50-60Hz, D=3/PE~200-210V 50-60Hz, F=2/PE~220-240V 50-60Hz, G=3/N/PE~415V 50-60Hz, H=3/PE~220-230V 50-60Hz, K=3/PE~380-400V 50-60Hz, L=3/PE~415V 50-60Hz, M=3/PE~440V 60Hz, P=1/N/PE~220-230V 50-60Hz, R=2/PE~220-240V 50-60Hz, U=1/N/PE~240V 50-60Hz, V=3/PE~240V 50-60Hz, W=1/N/PE~100-110V 50-60Hz