



**Applus®**  
LGAI  
Organismo  
Notificado  
**0370**

**AENOR**  
Organismo  
Notificado  
**0099**



TOLERANCIAS GENERALES:  $\pm 0.5$  mm

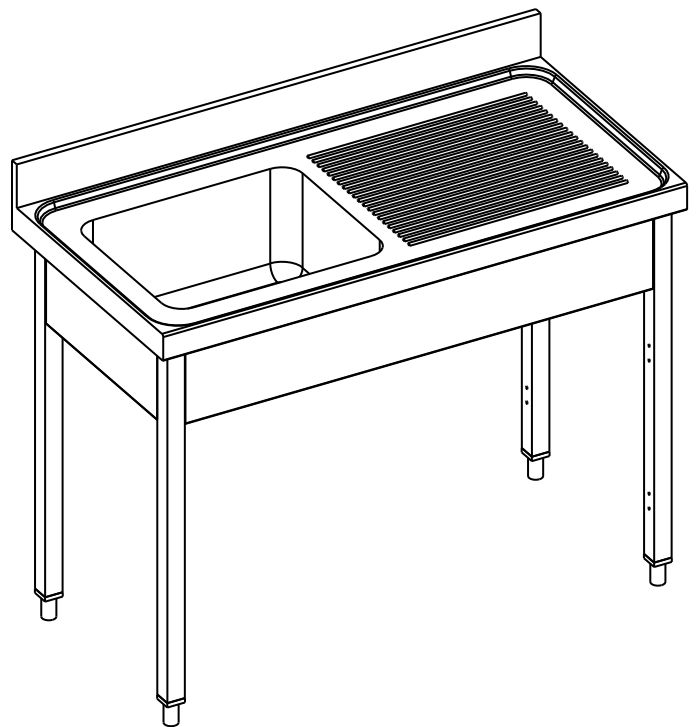
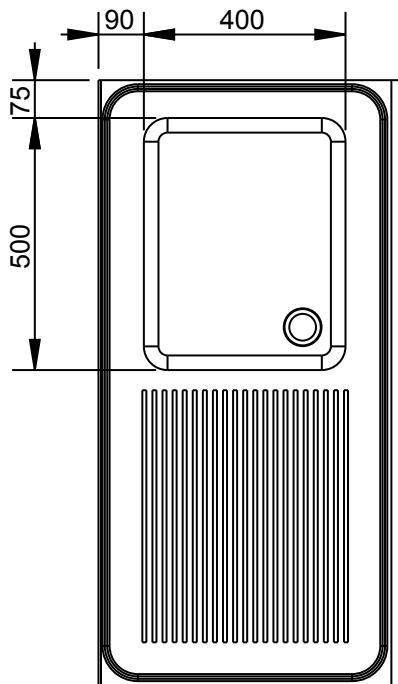
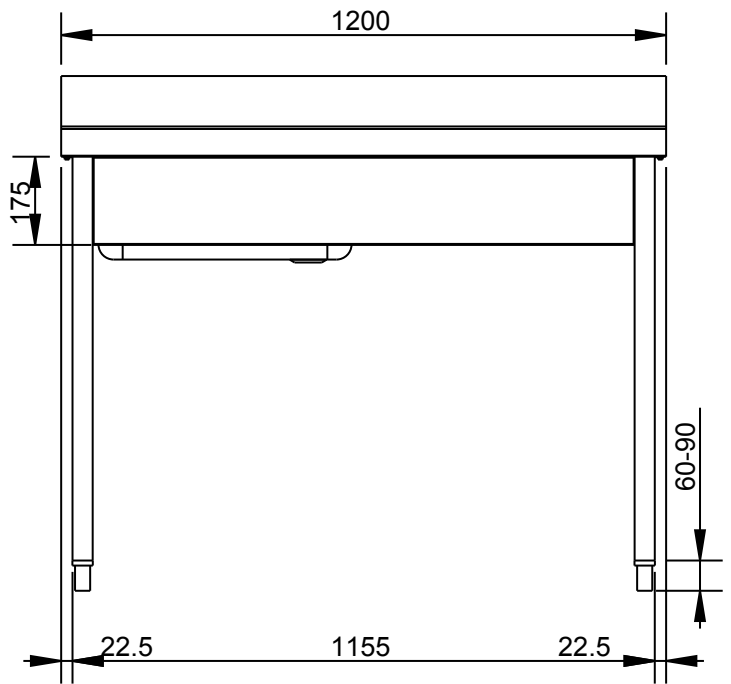
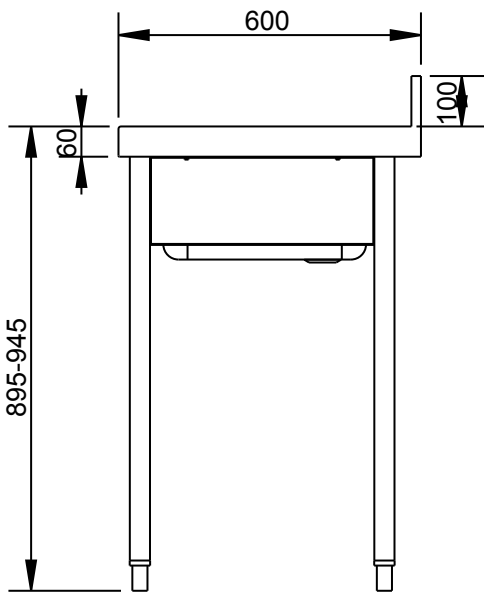

FAMILIA: NEUTRO 2008

FECHA: 14/04/11

MODELO: 212/1

PESO(Kg): 24.087

DENOMINACION:  
FREGADERO 1S/1E 1200X600

ESCALA:  
1/15

MATERIAL:  
INOX

CODIGO:  
2121



**Applus®**  
LGA1  
Organismo  
Notificado  
**0370**

**AENOR**  
Organismo  
Notificado  
**0099**



TOLERANCIAS GENERALES: ± 0.5 mm

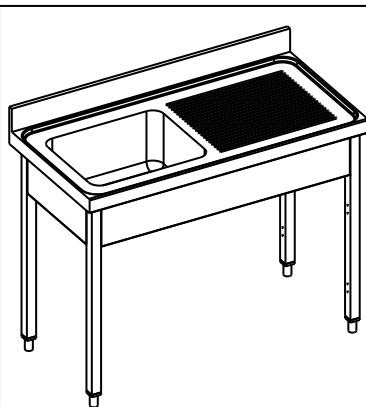

QT	COD	DESCRIPCION
2	212140	FRISO LATERAL FREGADERO 600
2	212165	FRISO FREGADERO FRONT/TRASERO
2	171208P	PATA DEL.DCHA./TRAS.IZQ.
2	171209P	PATA DEL.IZQ./TRAS.DCHA.
1	9210C	CONJ.FREGADERO 1S/1E 1200X600
4	C1062003	TORNILLO M-5X15 DIN933 ZN
16	C1064063	TORNILLO M-6X15 DIN933 ZN
4	C1260053	ARANDELA M-5 DIN-125 ZN
16	C1260243	ARANDELA M-6 DIN-125 ZN

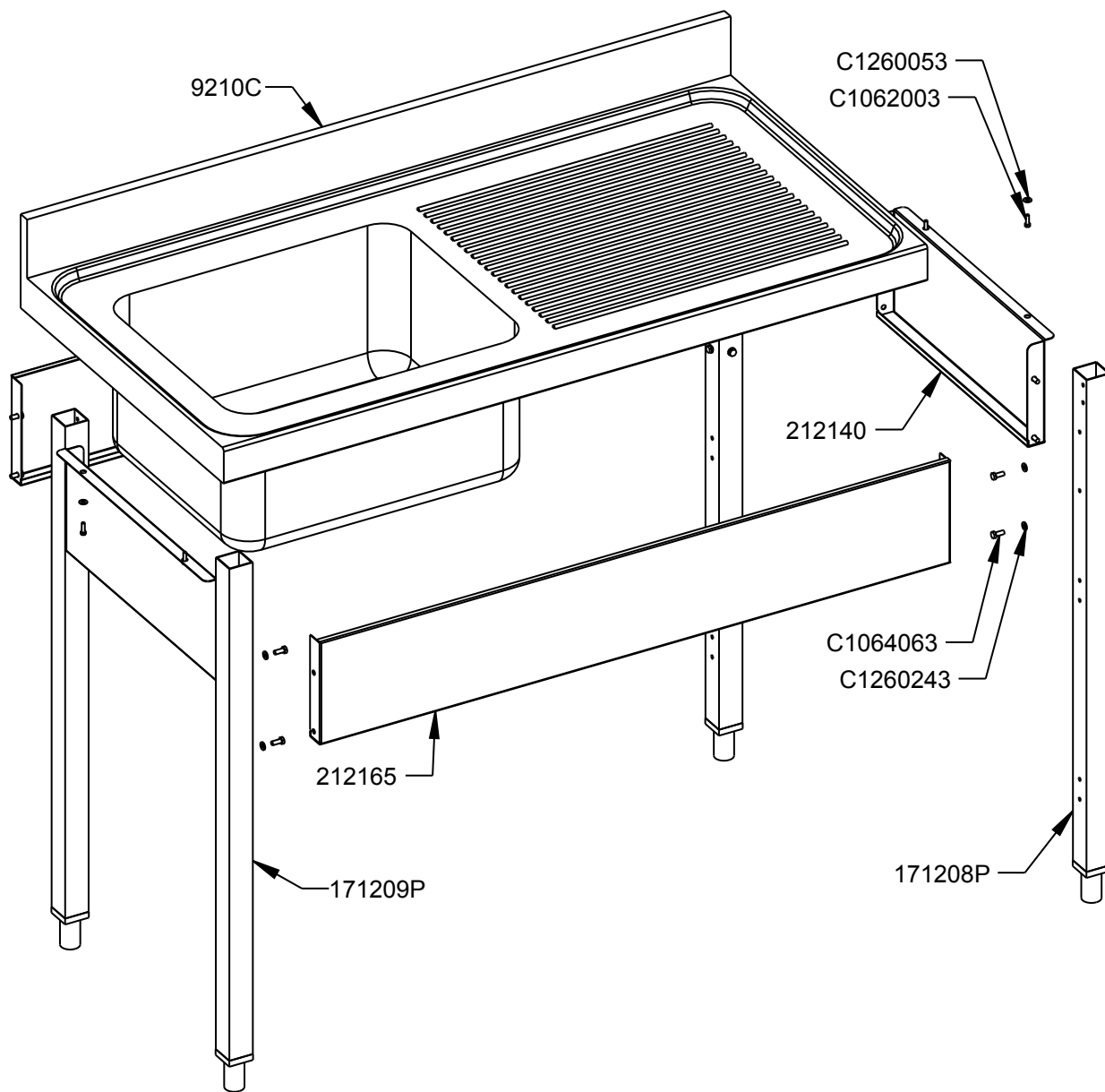

FAMILIA: NEUTRO 2008

FECHA: 14/04/11

MODELO: 212/1

PESO(Kg): 24.087

DENOMINACION:  
FREGADERO 1S/1E 1200X600

ESCALA:  
1/10

MATERIAL:  
INOX

CODIGO:  
2121



**Applus®**  
LGA1  
Organismo  
Notificado  
**0370**

**AENOR**  
Organismo  
Notificado  
**0099**



TOLERANCIAS GENERALES: ± 0.5 mm

QT	COD	DESCRIPCION	FAB.	MATERIAL	DATA	PESO
2	212140	FRISO LATERAL FREGADERO 600	SÍ	INOFER 1.2	30/03/11	1.044
2	212165	FRISO FREGADERO FRONT/TRASERO	SÍ	INOFER 1.2	30/03/11	2.298
1	212402	OMEGA FREGADERO 600	SÍ	GALVA 1.5	29/03/11	0.924
1	9210C	CONJ.FREGADERO 1S/1E 1200X600	SÍ	INOX	29/03/11	13.362
1	9210	FREGADERO 1S/1E 1200X600	NO	INOX	29/03/11	12.426
2	171208P	PATA DEL.DCHA./TRAS.IZQ.	NO	INOX □ 40x1.5	16/02/11	0.980
2	171209P	PATA DEL.IZQ./TRAS.DCHA.	NO	INOX □ 40x1.5	16/02/11	0.980
4	C1062003	TORNILLO M-5X15 DIN933 ZN	NO	FE ZN	03/02/09	0.003
16	C1064063	TORNILLO M-6X15 DIN933 ZN	NO	FE ZN	17/12/09	0.006
4	C1260053	ARANDELA M-5 DIN-125 ZN	NO	FE ZN	11/05/10	0.001
16	C1260243	ARANDELA M-6 DIN-125 ZN	NO	FE ZN	22/03/11	0.001
6	C1660109	REMACHE EXAG.ROSCADO M-5 S/CAB	NO	Fe ZN	24/03/11	0.002



FAMILIA: NEUTRO 2008

FECHA: 14/04/11

MODELO: 212/1

PESO(Kg): 24.087

DENOMINACION:  
FREGADERO 1S/1E 1200X600

ESCALA:  
1/8

MATERIAL:  
INOX

CODIGO:  
2121



**AENOR**  
Organismo Notificado  
**0099**

**Applus®**  
LGA1  
Organismo Notificado  
**0370**



TOLERANCIAS GENERALES: ± 0.5 mm

QT	COD	DESCRIPCION
1	9210	FREGADERO 1S/1E 1200X600
1	212402	OMEGA FREGADERO 600
6	C1660109	REMACHE EXAG.ROSCADO M-5 S/CAB

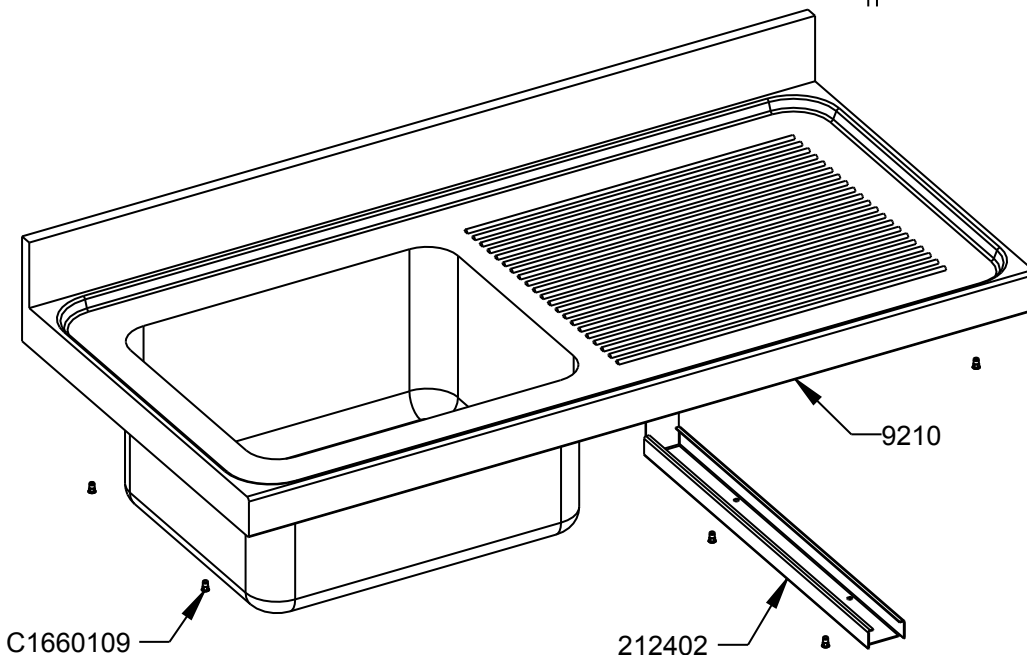
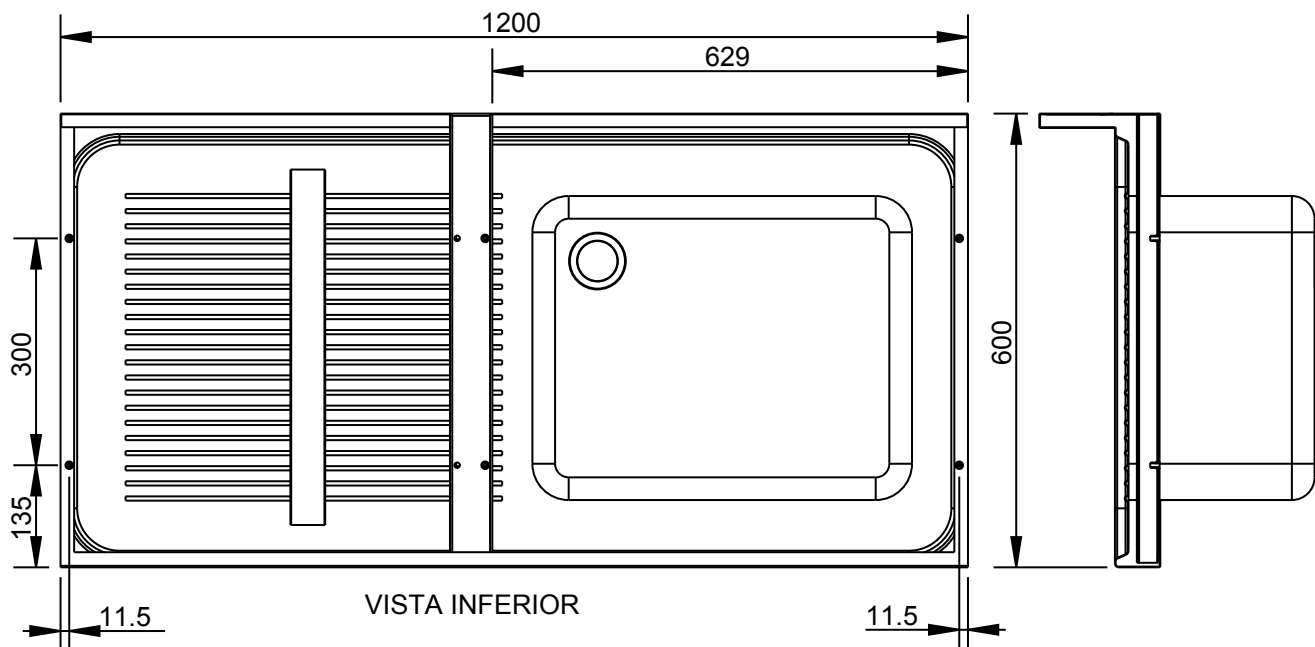
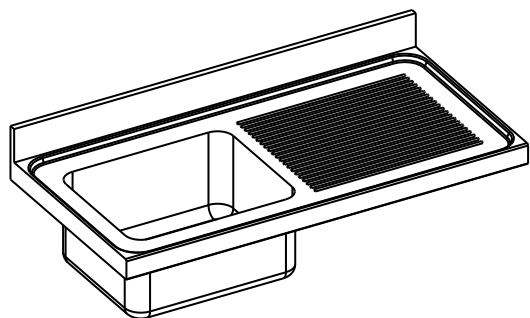

REF.	
O.F.	
QT.	
DEST.	



FAMILIA: NEUTRO 2008

FECHA: 29/03/11

MODELO: 212

PESO(Kg): 13.362

DENOMINACION:  
CONJ.FREGADERO 1S/1E 1200X600

ESCALA:  
1/10

MATERIAL:  
INOX

CODIGO:  
9210C