

CABINET ASSEMBLY+ HYDRAULIC CIRCUIT Mod. C300 A/W (Follow)

Ref.	Description	Refrigerant	A/W	Tension	Code
1	Sprayers bar assembly				C20144
2	Sprayer				D20002
3	Plastic nipple water outlet				10007
4	Overflow tube assembly				C10133
5	Bin thermostat				23421
6	Evaporator thermostat				23591
7	Anti radio interference filter		A	1-5	23459
8	Timer			1-4-5	23247
8	Timer			2-6	23222
9	Condenser pressure switch		A		23175
10	Orange led				23100
11	Pressure switch				23342
12	Top fixing pin				20024
13	Contactora				23147
14	Front panel (condenser side)				22203
15	Front panel assy (bin side)				C22432
16	Pump suction filter				20005
17	Sprayers bar pipe connection assy				C13036
18	Sprayers bar plug				10012
19	Discharges manifold		A		C10006
19	Discharges manifold		W		C10051
20	Suction impeller				10213
21	Hub+washer+screw				10014
22	Pump delivery pipe				13046
23	Pump motor				23068
24	Inlet water valve 2 ways		A		23157
24	Inlet watervalve 3 ways		W		C23160
25	Back panel				22195
26	Top assembly				C22481
27	Evaporator basin				10055
28	Evaporator cover				10058
29	Flags support assy				C22134
30	Ice cubes slide				D12022
31	Water discharge pipe (upper bin)				13048
32	Evaporator cover				10115
33	Machined bin assembly				C26329
34	Water discharge pipe (lower bin)				13049
35	Pump suction pipe				13047

Note: Code C22432 from construction no. 9406718594. Previous serial no. C22202.

COOLING SYSTEM ASSEMBLY Mod. C300 A/W - Cube A (Cod. 24100)

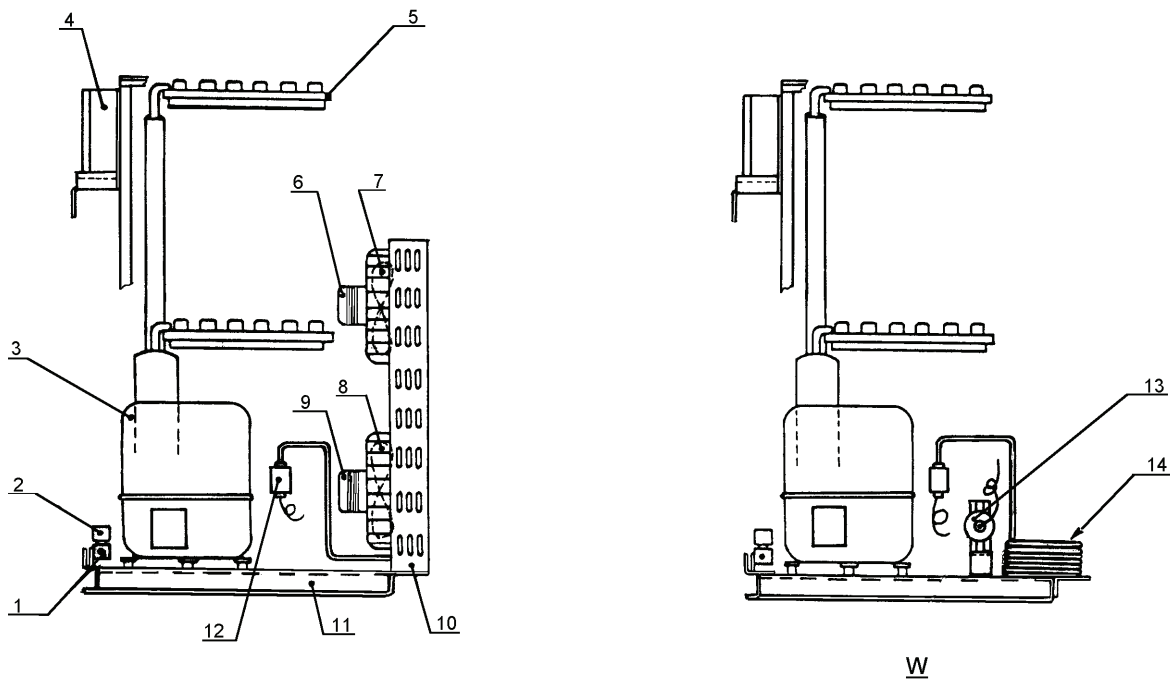

Ref.	Description	Refrigerant	A/W	Tension	Code
1	Hot gas valve body				20409
2	Hot gas coil				23091
3	Compressor	R404A		1	23489
3	Compressor	R404A		2	23527
3	Compressor	R404A		4-6	23563
3	Compressor	R404A		5	23453
3	Compressor	R22		1	23150
3	Compressor	R22		2	23433
3	Compressor	R22		4	23288
3	Compressor	R22		5	23289
3	Compressor	R22		6	23434
4	Box for compressor electrical kit	R22		1	C23230
4	Box for compressor electrical kit	R22		2	C23296
5	Evaporator				D10214
6	Fan motor		A		23121
7	Suction fan 275-34		A		20153
8	Suction fan 254/34		A		20031
9	Lower fan motor		A	1-4-5	23067
9	Lower fan motor		A	2-6	23580
10	Air condenser		A		20406
11	Base plate				21110
12	Solid core drier				14084
13	Pressure valve		W		20149
14	Water condenser		W		14285

Note: Code 14285 from 16/02/93. Before Code 14109.
 Code 20406 from serial no. 96090025180. Previous serial no. Code 20197.
 Code 20153 from serial no. 96090025180. Previous serial no. Code 20031.

Erklärung zu Ersatzteillisten in den Spalten Tension-Spannung

1	Spannung	220-240V	50Hz
2	Spannung	220-230V	60Hz
3	Spannung	110 115V	60Hz
4	Spannung	230V3P	50Hz
5	Spannung	400V	50Hz
6	Spannung	220-230V3P	60Hz
7	Spannung	440-460V3P	60Hz