

TDE470 Service Parts

This parts lists contains part numbers for the service parts available for the TDE470.

The TDE470 has been manufactured in both 60 Hz and 50 Hz models.

The 60 Hz models are:

- TDE470AE-1A
- TDE470AS-1A

The 50 Hz models are:

- TDE470AE-6A
- TDE470AS-6A

Always check the model number of the ice machine being serviced to be certain that the parts ordered will be correct.

Table of Contents

Cabinet	Page 2
Condensing Components.....	Page 3
Evaporator, Auger, Bearings & Water Seal.....	Page 4
Water And Drain System	Page 5
Bin Cover, Dispenser Motor, Electric Eyes	Page 6
Gear Reducer and Motor	Page 7
Control Box.....	Page 8
Wiring Diagrams.....	Page 9

TDE470 Service Parts Cabinet

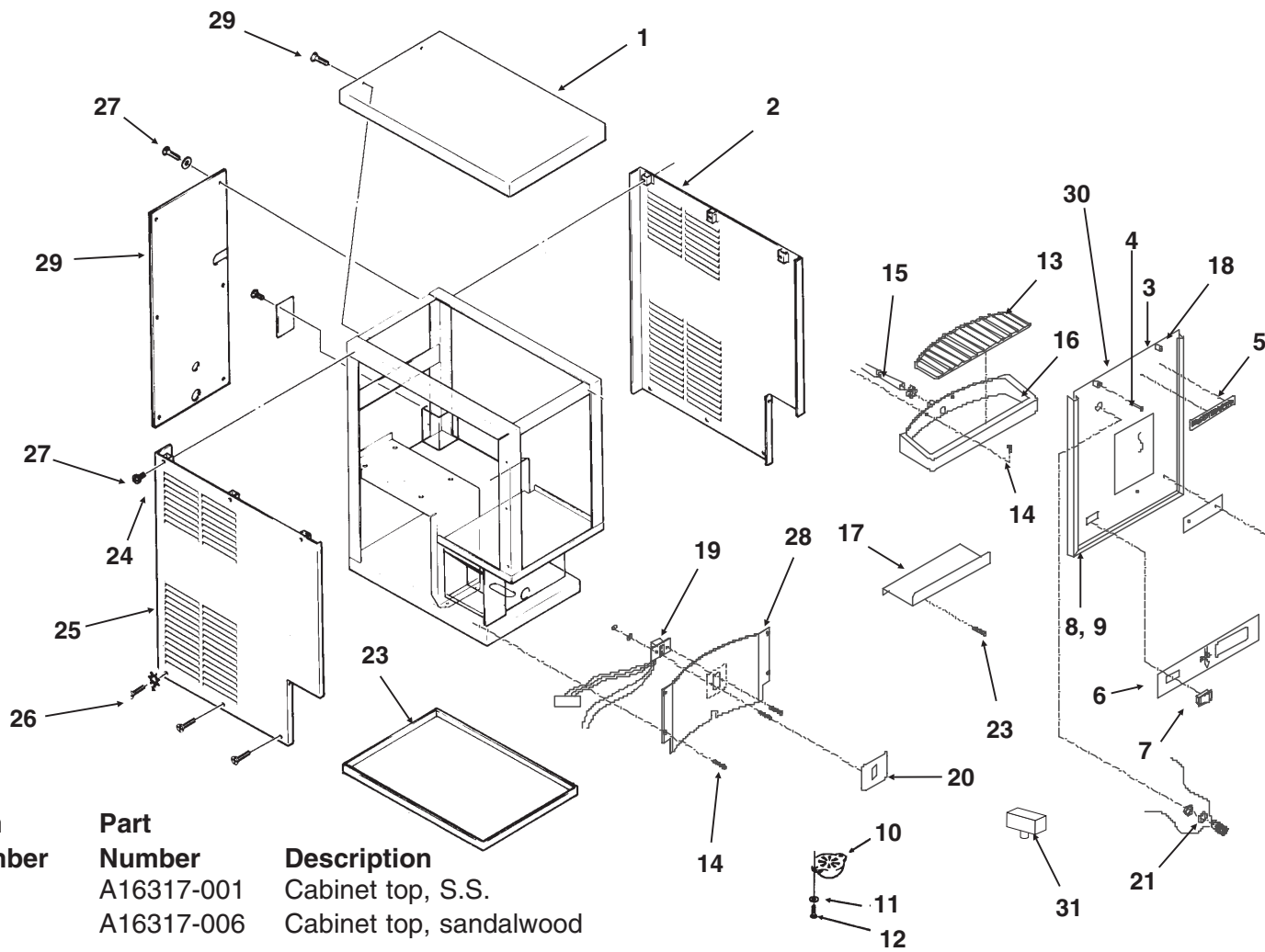

Item Number	Part Number	Description	Item Number	Part Number	Description	
1	A16317-001	Cabinet top, S.S.	19	12-2551-01	Touch free sensor	
	A16317-006	Cabinet top, sandalwood		20	17-2288-06	Decal
	A16317-015	Cabinet top, gray			21	12-2391-01
2	A21416-001	Right side panel, SS	22			03-1360-00
	A21416-004	Rt side panel, sandalwood		23		13-0566-00
	A21416-015	Rt side panel, gray			24	03-1417-27
3	13-0616-00	Rubber bumper	25			A21415-004
	4	03-1404-11		Screw		26
5		15-0718-01		Emblem for sandalwood	27	
	15-0718-02	Emblem for S.S. or gray	28	03-1419-27		
6	17-2360-01	Touch Free decal		29		A21405-004
	7	12-1377-00			Switch	30
8		03-1403-15	Screw		31	
	9	03-1417-27	Washer	10		
10		02-1804-00	Spout			11
	11	03-1407-03	Washer		12	
12		03-1403-19	Screw			
	13	02-3302-01	Grill			
14	03-1419-17	Screw				
15	13-0674-07	Tube, order 3 units.				
16	02-3402-30	Sink				
17	A35875-001	Bracket				
18	15-0507-00	Moulding trim				

TDE470 Service Parts

Condensing Components

Item Number	Part Number	Description
1	18-8741-21	60 Hz compressor
	18-8741-26	50 Hz compressor
2	18-8741-27	Overload for 60 Hz
	18-8741-22	Overload for 50 Hz
3	18-8741-28	60 Hz relay
	18-8741-23	50 hz relay
3	18-8741-29	Start capacitor for 60 Hz
	18-8741-24	Start capacitor for 50 Hz
4	03-1647-01	Screw
	03-1417-12	Washer
	03-1407-07	Washer
	18-4700-28	Grommet
5	18-0108-41	Sleeve
6	16-0832-21	Access valve
6a	16-0832-03	Core cap
6b	16-0832-02	Stem cap
7	18-0422-00	Fan motor bracket
8	18-7200-02	60 Hz fan motor
	18-7200-03	50 Hz fan motor
9	18-8743-01	Fan blade
10	A36094-001	Fan shroud
11	18-8846-01	Condenser
12	02-3319-01	Drier

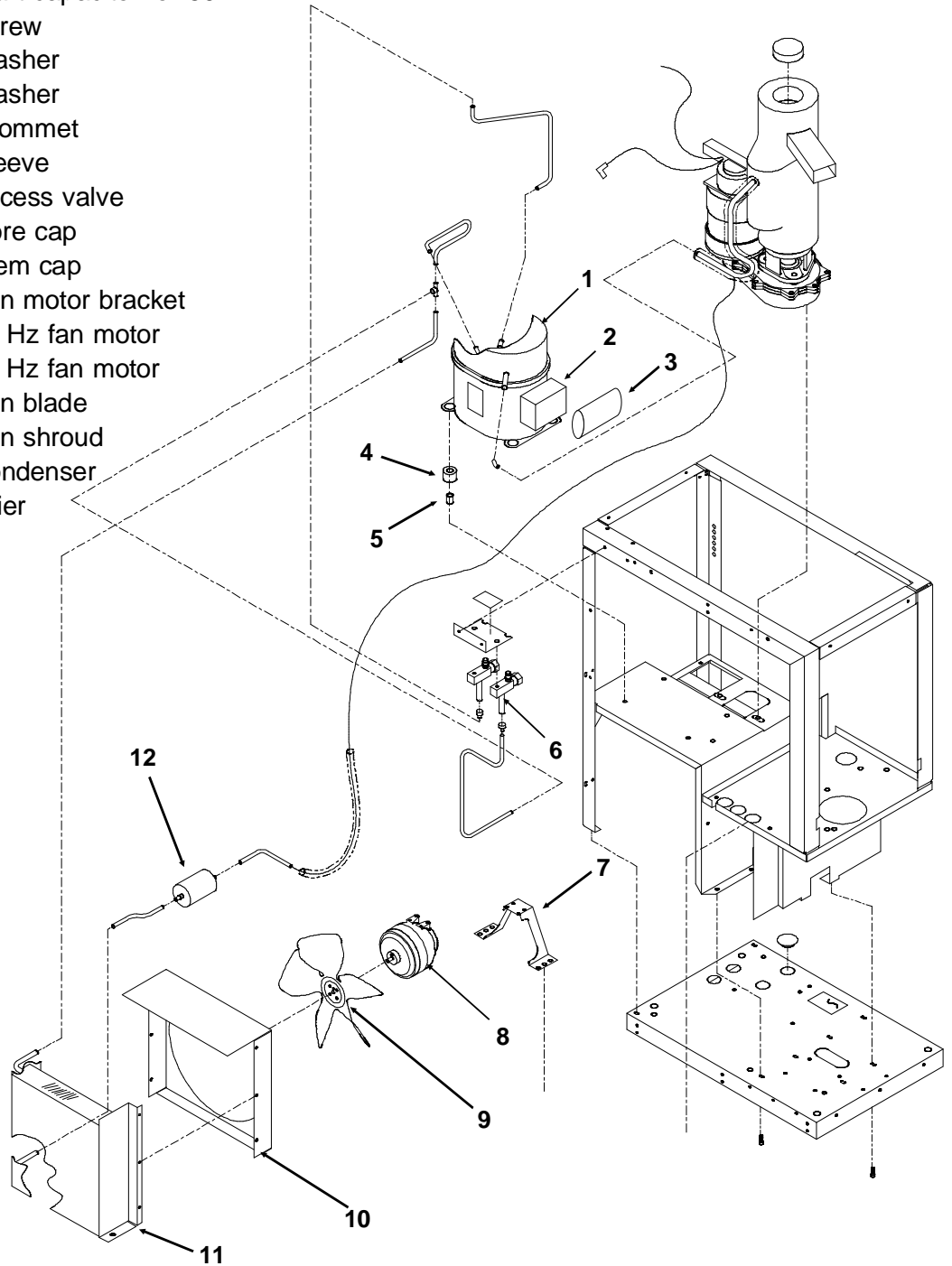

TDE470 Service Parts

Evaporator, Auger, Bearings & Water Seal

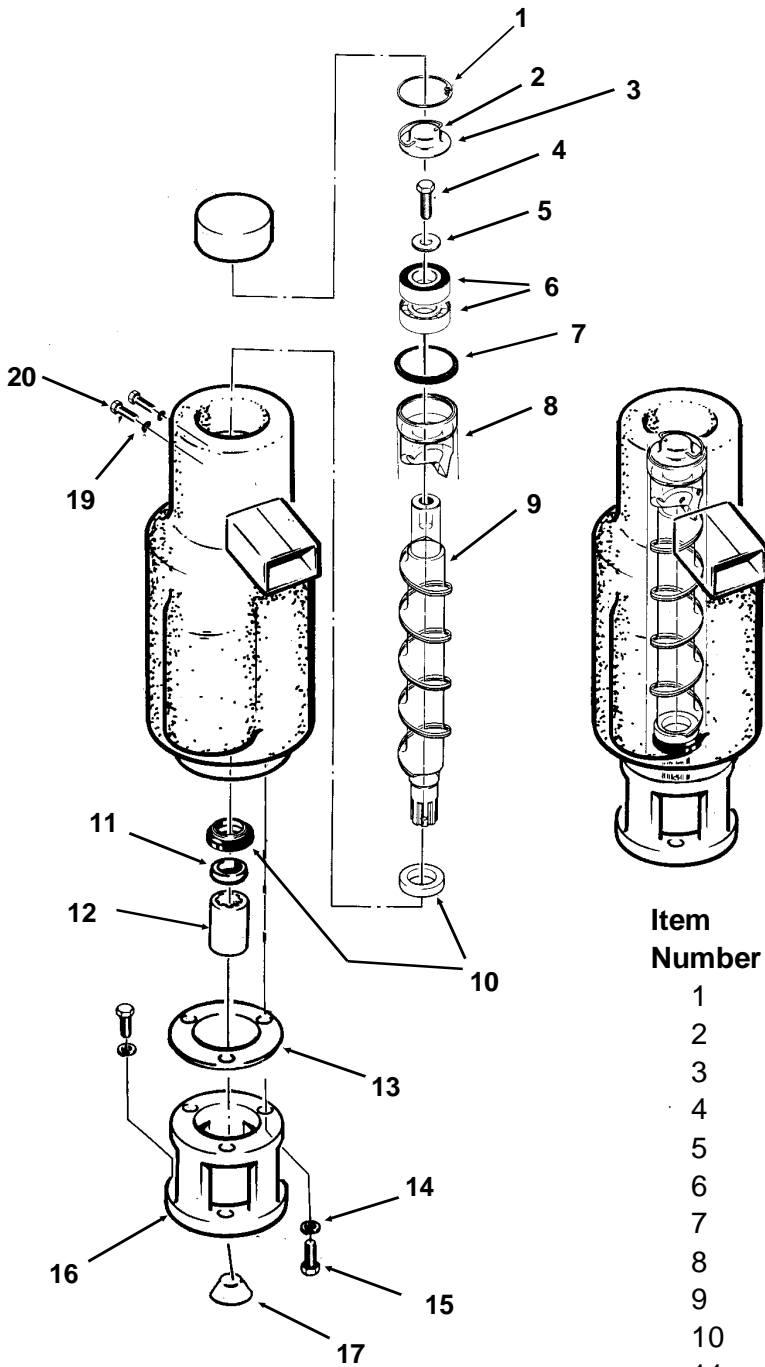

Item Number	Part Number	Description
1	03-1558-03	Retainer Ring
2	A08162-000	Cap hook
3	A07701-000	Cap
4	03-0758-00	Screw
5	A07699-000	Washer
6	02-1412-20	Top bearing set
7	13-0617-16	"O" ring
8	A14678-020	Breaker with bearing
9	A29669-001	Auger
10	02-1300-01	Water seal
11	02-0417-20	Bottom bearing
12	A29915-002	Coupling
13	03-1505-00	Gasket
14	03-1410-04	Washer
15	03-1420-01	Cap screw
16	08-0595-01	Adapter
17	13-0709-01	Rubber drip shield
18	A36081-020	Evaporator
19	03-1417-07	Washer
20	03-1403-46	Screw

TDE470 Service Parts

Water And Drain System

Item Number	Part Number	Description
1	A34768-001	Vane Assembly
2	A34767-001	Bin Bottom Assy
3	02-3033-01	Hub Assembly
4	03-1409-22	Fiber Washer
5	A36118-001	Storage Bin
6	13-0895-01	Inlet water line requires 26"
7	03-1394-00	Pal Nut
8	12-1434-04	Water valve (60 Hz)
	12-1434-05	Water valve (50 Hz)
9	16-0869-01	Barbed adapter
10	13-0674-02	Tubing, 12" req.
11	A33101-022	Water sensor
12	02-3402-30	Sink
13	02-3302-01	Grill for sink
14	13-0674-08	Tube, requires 12"
15	02-2814-10	Clamps
16	13-0079-03	Tube, overflow to drain, requires 12"
17	02-2814-08	Clamp
18	02-2814-07	Clamp
19	02-3371-20	Reservoir Assy
20	A36402-001	Reservoir Bracket
21	02-3371-21	Float and arm
21a	02-3266-22	Plunger/seat
22	03-1407-05	Plain Washer
23	03-1645-01	Hex Cap Screw
24	16-0812-01	Tube (to evap.)
25	A21433-000	Inlet fitting
26	16-0870-01	NPT to compr. fitting
27	16-0871-01	Brass insert

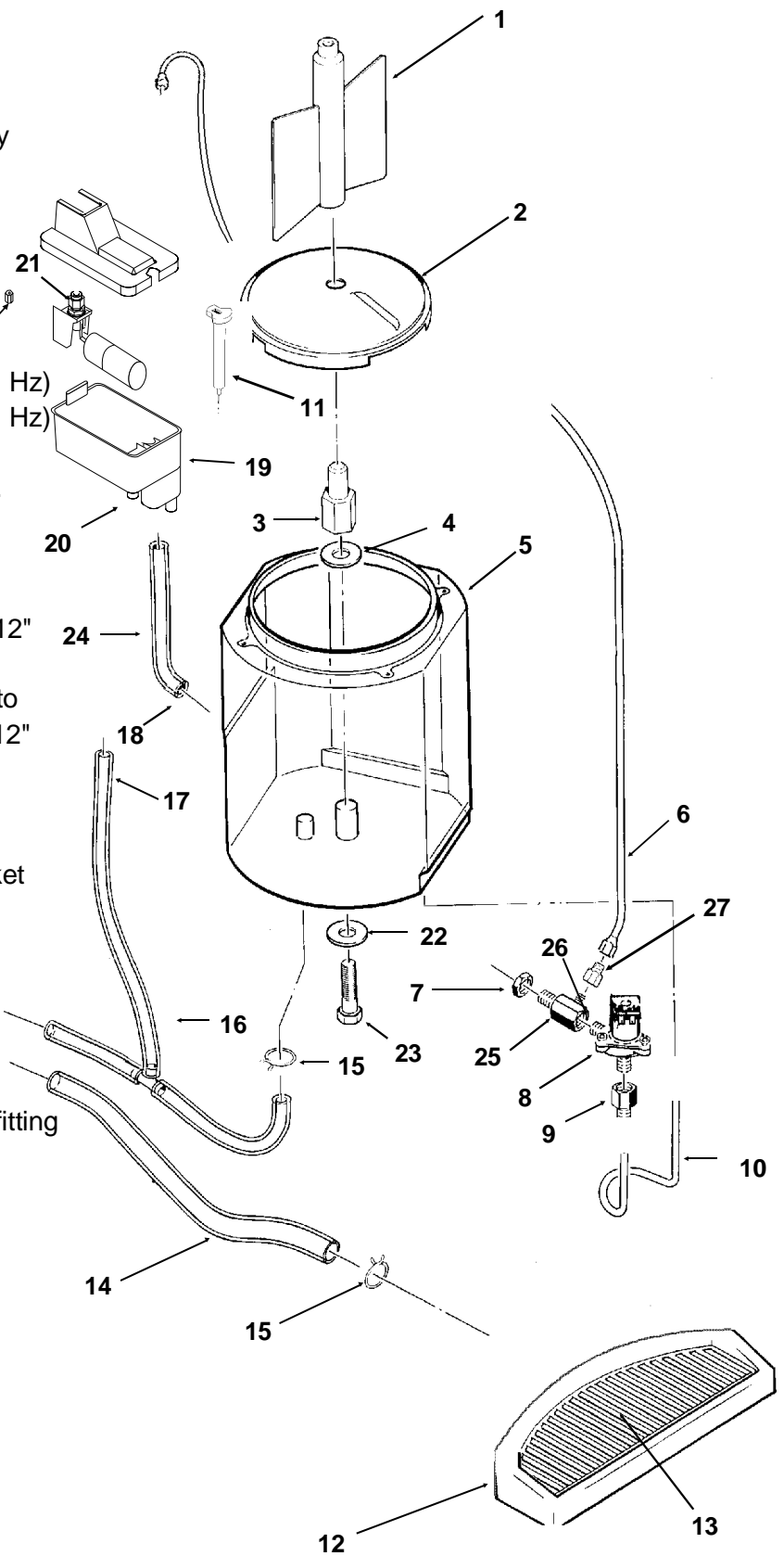

TDE470 Service Parts

Bin Cover, Dispenser Motor, Electric Eyes

Item Number	Part Number	Description
1	03-1403-15	Screw
2	03-1531-01	Screw
3	A35474-001	Motor Mtg. Bracket
4	02-3238-01	Bushing
5	03-0727-10	Thumbscrew
6	13-0866-01	Grommet
7	A36186-020	Electric eye set
8	02-3237-01	Bin top
9	02-3239-01	Nut
10	02-3241-01	Shaft
11	12-1610-21	Motor & gears 60 Hz
	12-1610-26	Motor & gears 50 Hz
12	02-1801-02	Strap

A35483-021 Complete assembly 60 Hz (except item 7)
 A35483-026 Complete assembly 50 Hz (except item 7)

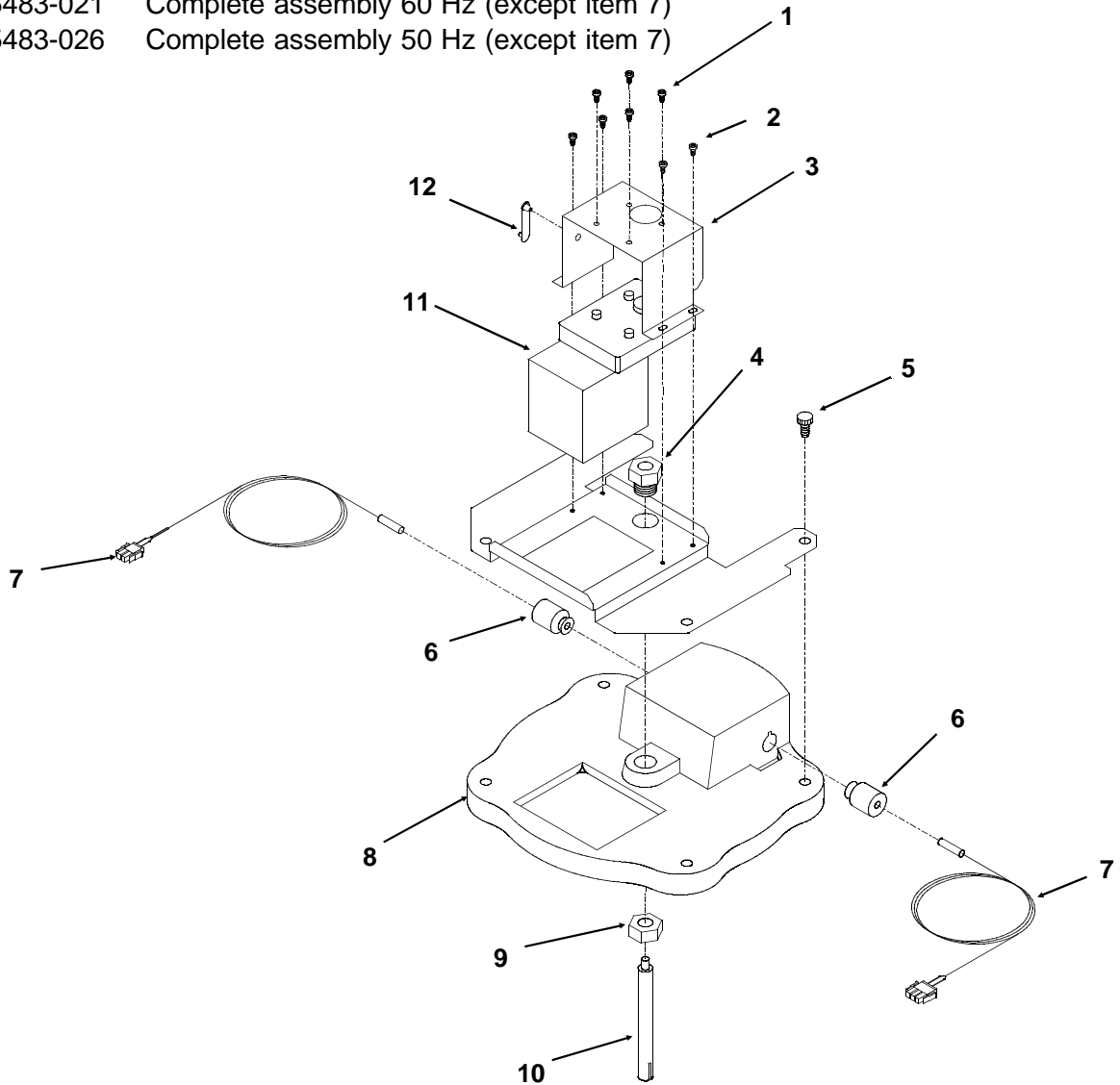

TDE470 Service Parts

Gear Reducer and Motor

Item Number	Part Number	Description
1	A27494-001	Centrifugal switch kit
2	12-2059-01	Switch
3	A27895-001	Housing
4	03-1403-77	Screw
5	A30579-001	Shaft & actuator
6	03-1408-36	Washer
7	A17047-002	Motor housing
8	A28168-001	Cooling fan
9	A37707-021	Motor kit, 115/60/1
	A38501-001	Motor kit, 50 Hz
10	no number, part of item 9	
11	03-1408-08	Washer
12	02-1501-00	Bearing
13	02-3969-20	Grease seal (input)
14	02-1503-00	Grease seal (output)
	13-0941-01	Water shed, not shown
15	A28165-021	Gear case cover
16	03-1408-21	Washer
17	03-1408-04	Washer
18	02-2445-01	Output shaft
19	03-1515-03	Retaining ring
20	03-1602-01	Woodruff key

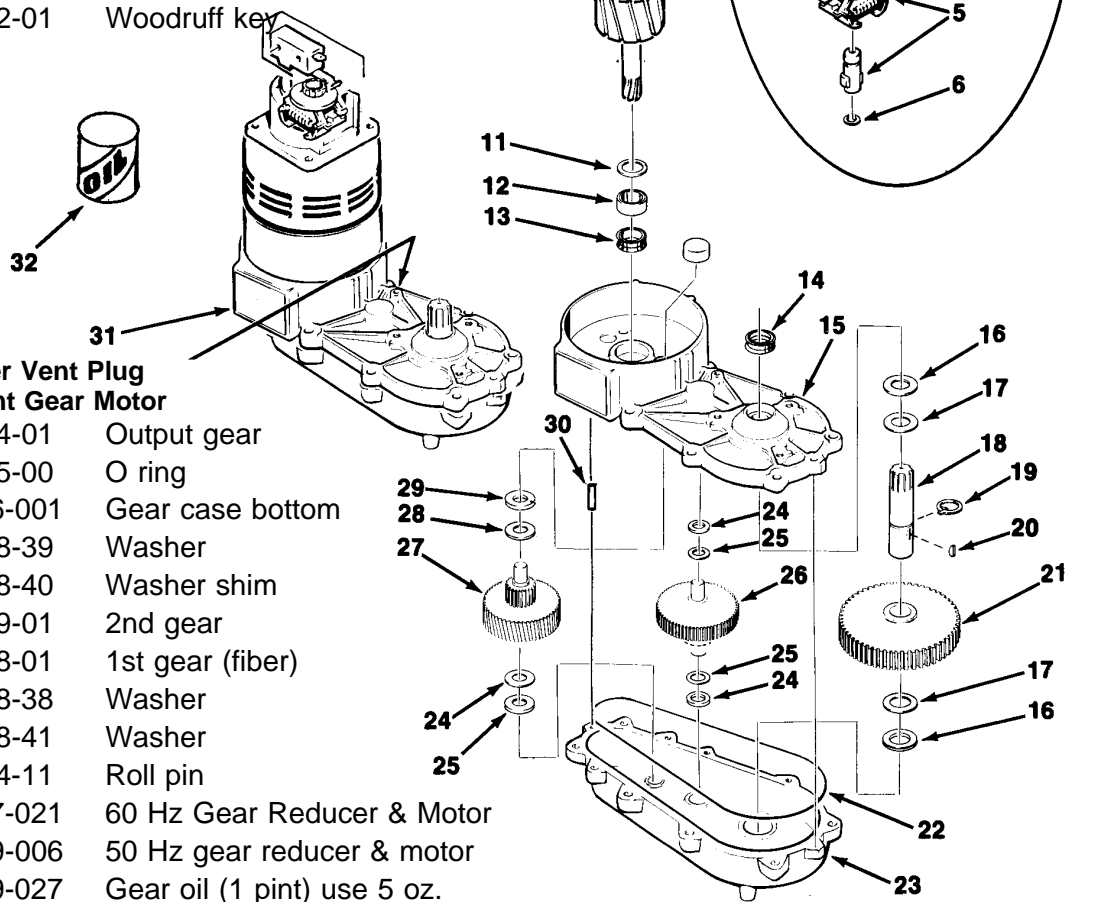
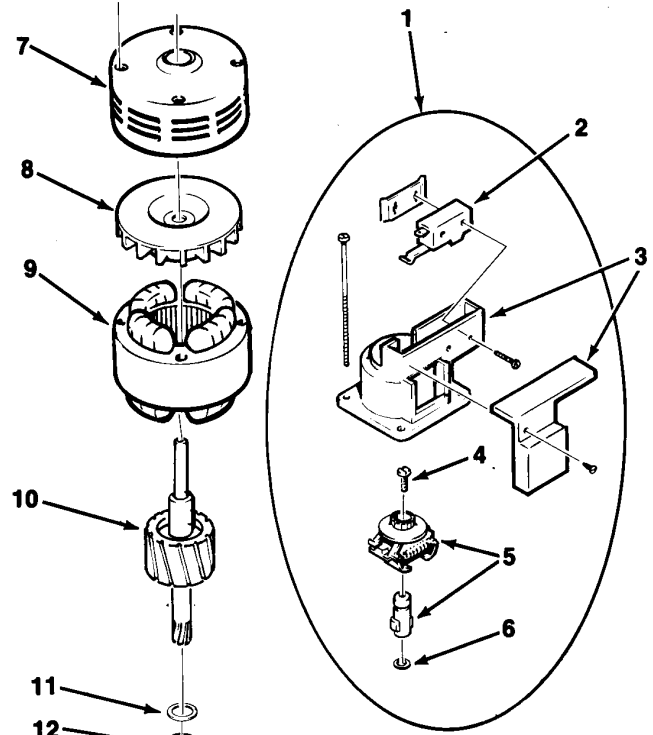

Remove Rubber Vent Plug From Replacement Gear Motor

21	02-2444-01	Output gear
22	02-1505-00	O ring
23	A28166-001	Gear case bottom
24	03-1408-39	Washer
25	03-1408-40	Washer shim
26	02-2439-01	2nd gear
27	02-2438-01	1st gear (fiber)
28	03-1408-38	Washer
29	03-1408-41	Washer
30	03-0774-11	Roll pin
31	A31977-021	60 Hz Gear Reducer & Motor
	A36549-006	50 Hz gear reducer & motor
32	A32379-027	Gear oil (1 pint) use 5 oz.

TDE470 Service Parts

Control Box

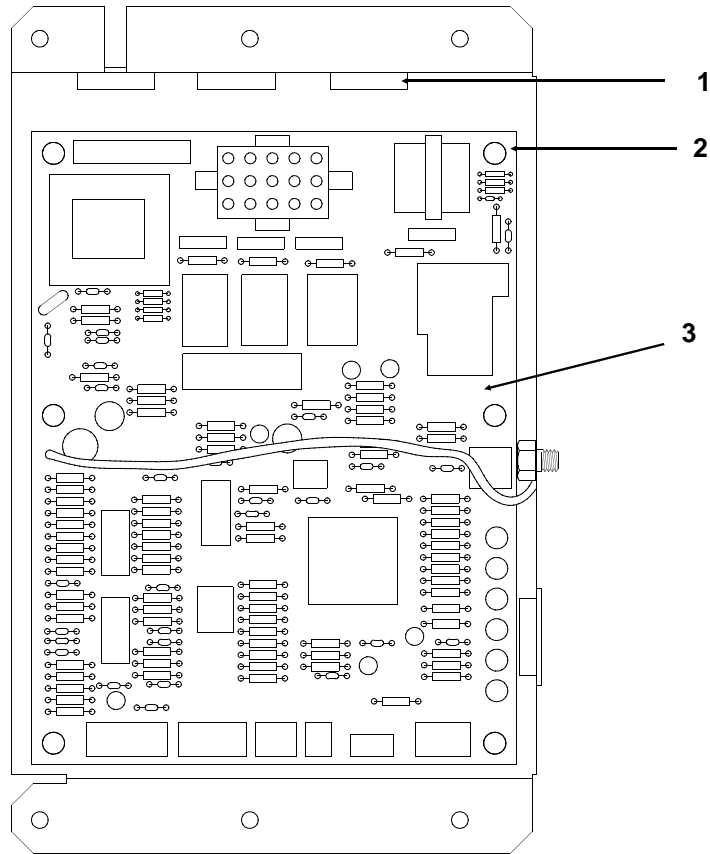

Item Number	Part Number	Description
1	12-1213-10	Snap bushing
2	12-2499-01	Stand off
3	12-2843-21	Circuit board for 115/60/1
	12-2843-26	Circuit board for 220/50/1
	12-2549-01	Board harness (not shown)

Not Shown: Sink Extension Kit, KDE1A and KDE1A-SS

1	17-2288-05	Ice Label
2	02-2809-01	Drain top
3	A18331-000	Drain fitting
4	02-1699-00	Sink
5	02-1701-00	Grill
6	02-3446-01	Splash panel
7	13-0617-11	O-ring
8	A21538-000	Base support - enamel
	A21538-001	Base support - stainless steel

TDE470 Service Parts Wiring Diagram TDE470AE-1A

A36522-001

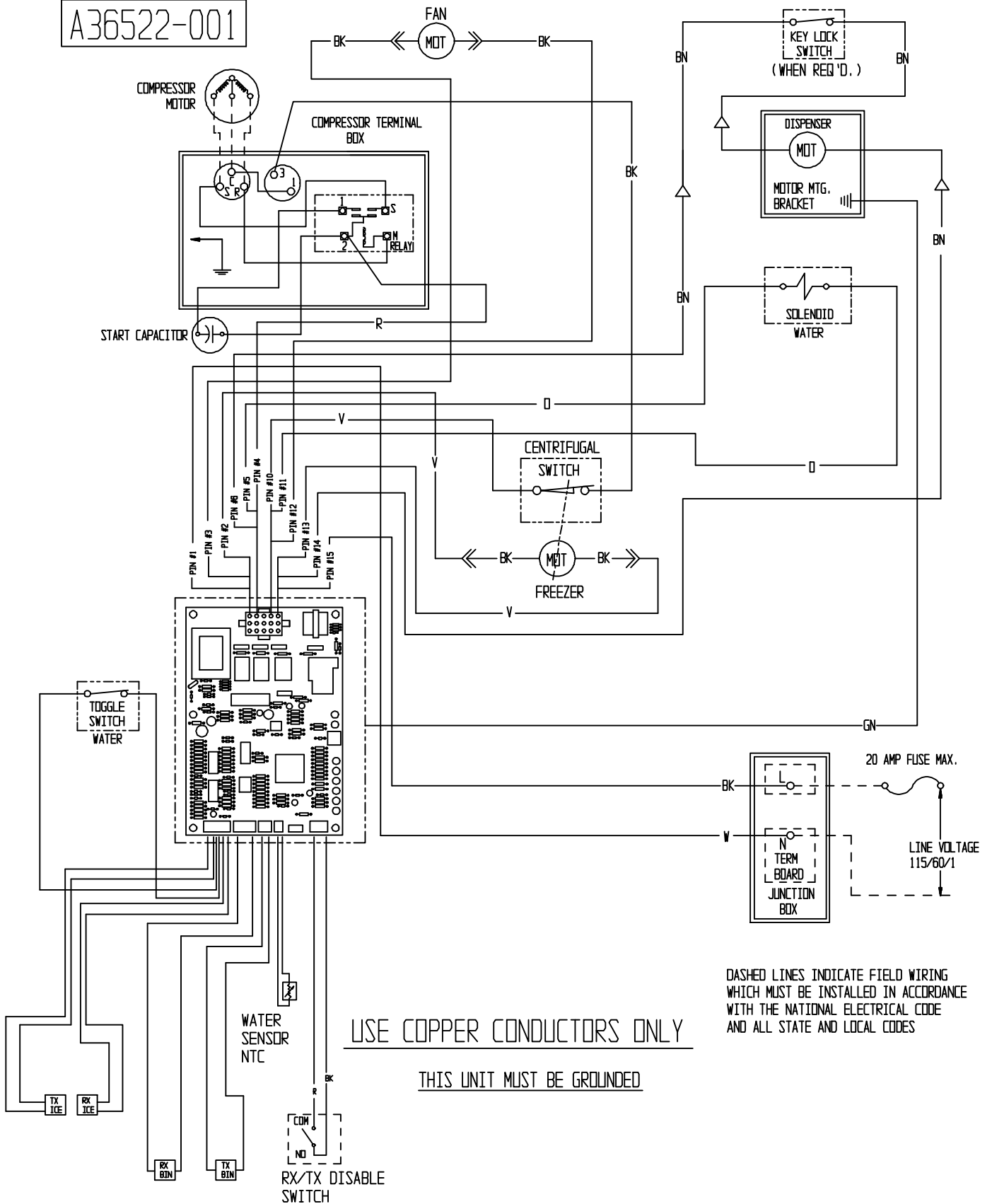

USE COPPER CONDUCTORS ONLY

THIS UNIT MUST BE GROUNDED

DASHED LINES INDICATE FIELD WIRING WHICH MUST BE INSTALLED IN ACCORDANCE WITH THE NATIONAL ELECTRICAL CODE AND ALL STATE AND LOCAL CODES

TDE470 Service Parts

Schematic Diagram

TDE470AE-1A

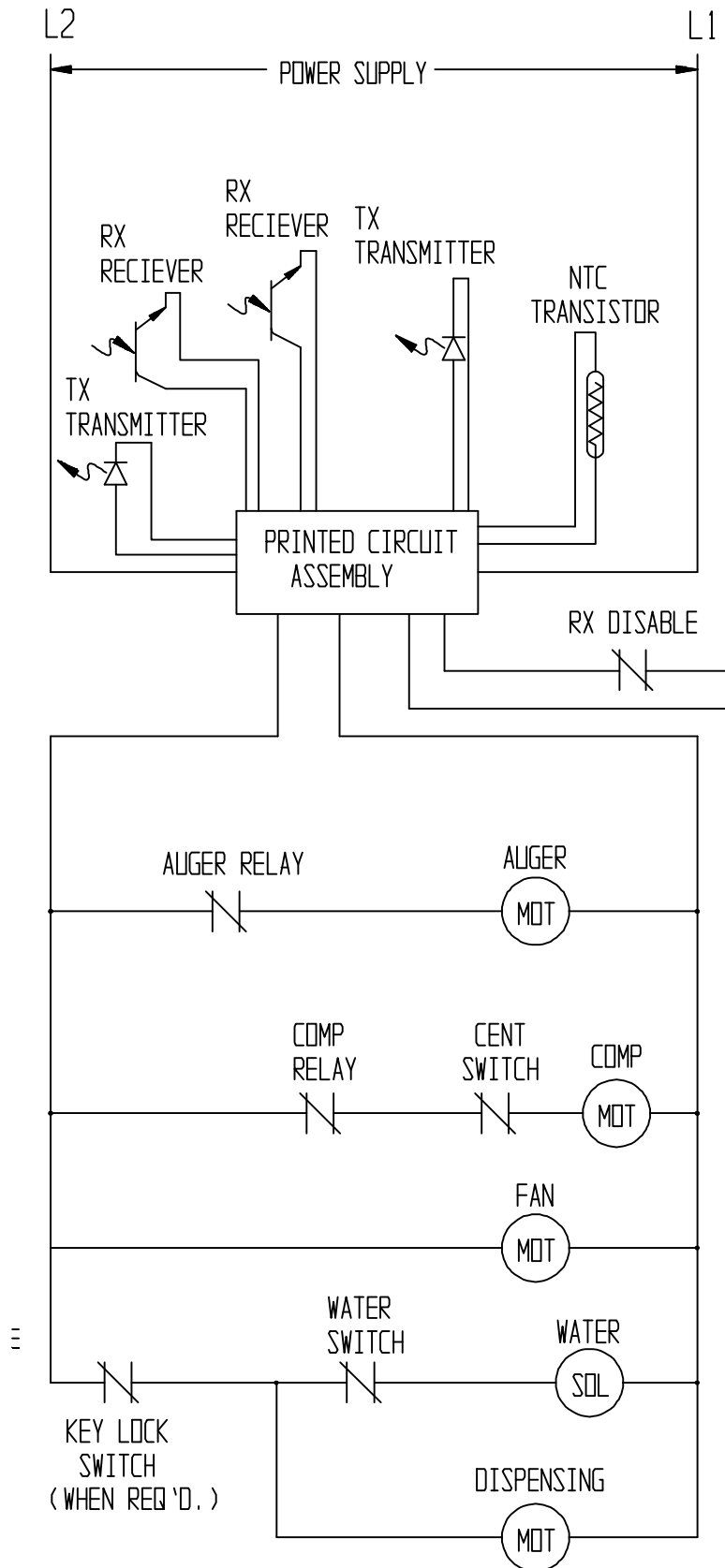

Controls shown in the ice making mode with all dispensing systems in operation.

TDE470 Service Parts

Wiring Diagram TDE470AE-6A

