

CSW45 Service Parts

This is the list of service parts for the CSW45. Because products do change over time, be sure to obtain the complete model and serial numbers from the ice machine being serviced and use that information to confirm the part numbers.

In July 2001 the compressor was changed. CSW45A-1A and CSW45PA-1A use the original compressor and related parts, while the "B" series (CSW45A-1B and CSW45PA-1B) thru the D series use the new compressor and related parts. Be sure to check the complete model number when ordering compressor components. C and D series also have specific parts changes.

Table of Contents

Cabinet	Page 2
Cabinet Parts	Page 3
Condensing Unit	Page 4
Condensing Unit Parts	Page 5
Control Panel	Page 6
Water System	Page 7
Water System Parts	Page 8
Wiring Diagram.....	Page 9

CSW45 Service Parts Cabinet

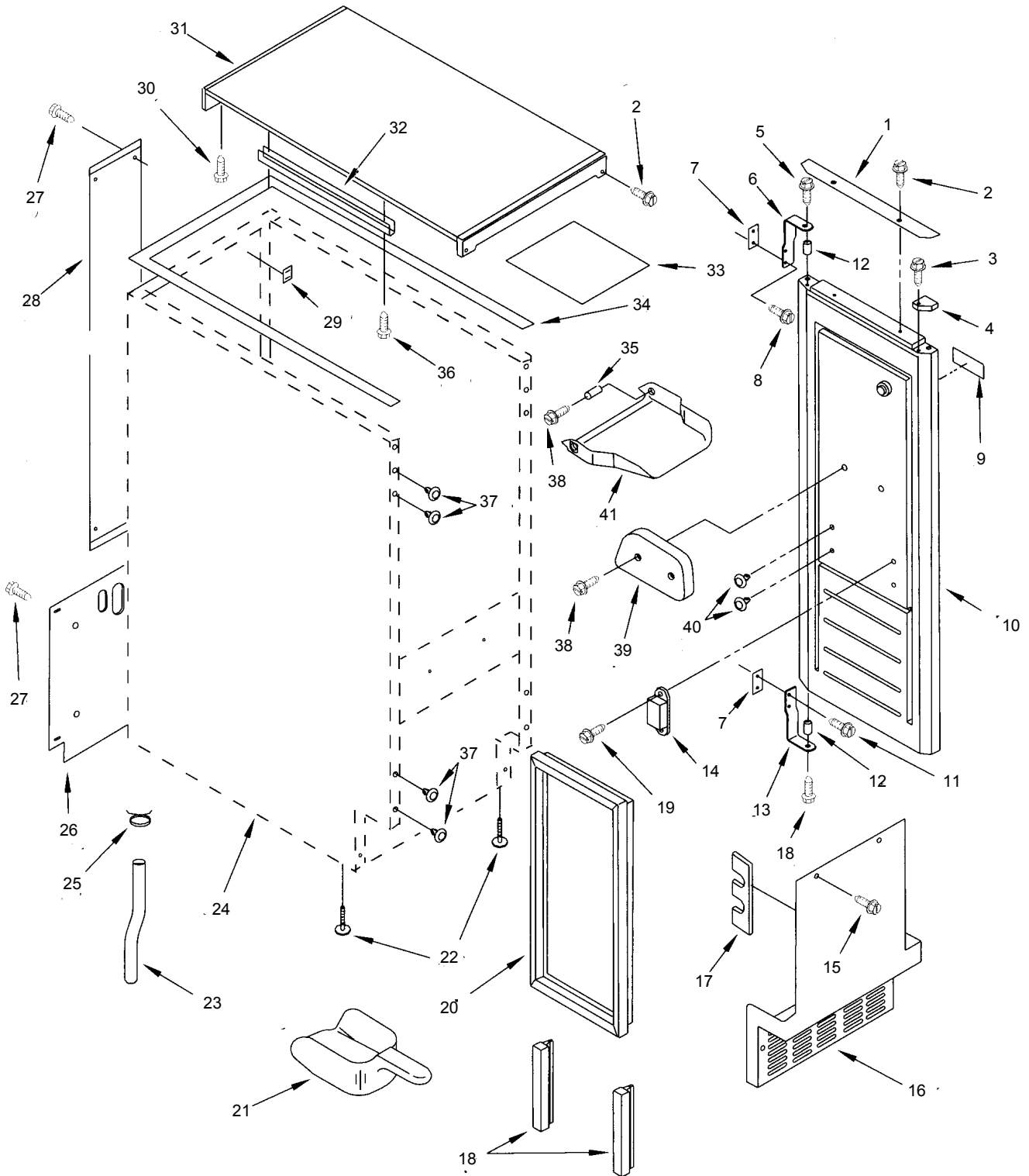

CSW45 Service Parts

Cabinet Parts

Item Number	Part Number	Description
1	02208495W	Door handle
2	08281137	Screw
3	0348689	Screw
4	02185655W	Left side filler
	02185656W	Right side filler
5	02185712	Hinge pin
6	02185710	Top hinge
7	02185719	Shim for hinge
8	0489423	Screw
9	02185977	Emblem
10	04388362	Door
11	0489423	Screw
12	02185640	Sleeve
13	02185711	Bottom hinge
14	02185859	Magnetic catch
15	02185991	Screw
16	02185571W	Front grill
17	02185756	Foam pad
18	02185777	Bottom gasket
19	0488163	Screw
20	02185776	Door gasket for A, B or C series
	02217294	Door gasket for D series
21	02-3070-01	Scoop
22	03376439	Leg leveler
23	02185671	Drain tube
24	no number	Cabinet, not replaceable
25	0596023	Clamp
26	02185730	Cover
27	03400881	Screw
28	02185575	Cover for wiring
29	02154101	Clip for fill tube
30	0488868	Screw
31	02929700W	Top for A, B or C series
	02217293	Top for D series
32	02185691	Channel for wiring
33	02185690	Electrical shield
34	02185645	Top gasket
35	02185678	Spacer
36	03400884	Screw
37	02151652	Hole plug
38	03400886	Screw
39	02185695	Door cam
40	02189000	Hole plug
41	02185742	Bin door
42	02217361	Gasket, leg for D series, Not shown

CSW45 Service Parts Condensing Unit

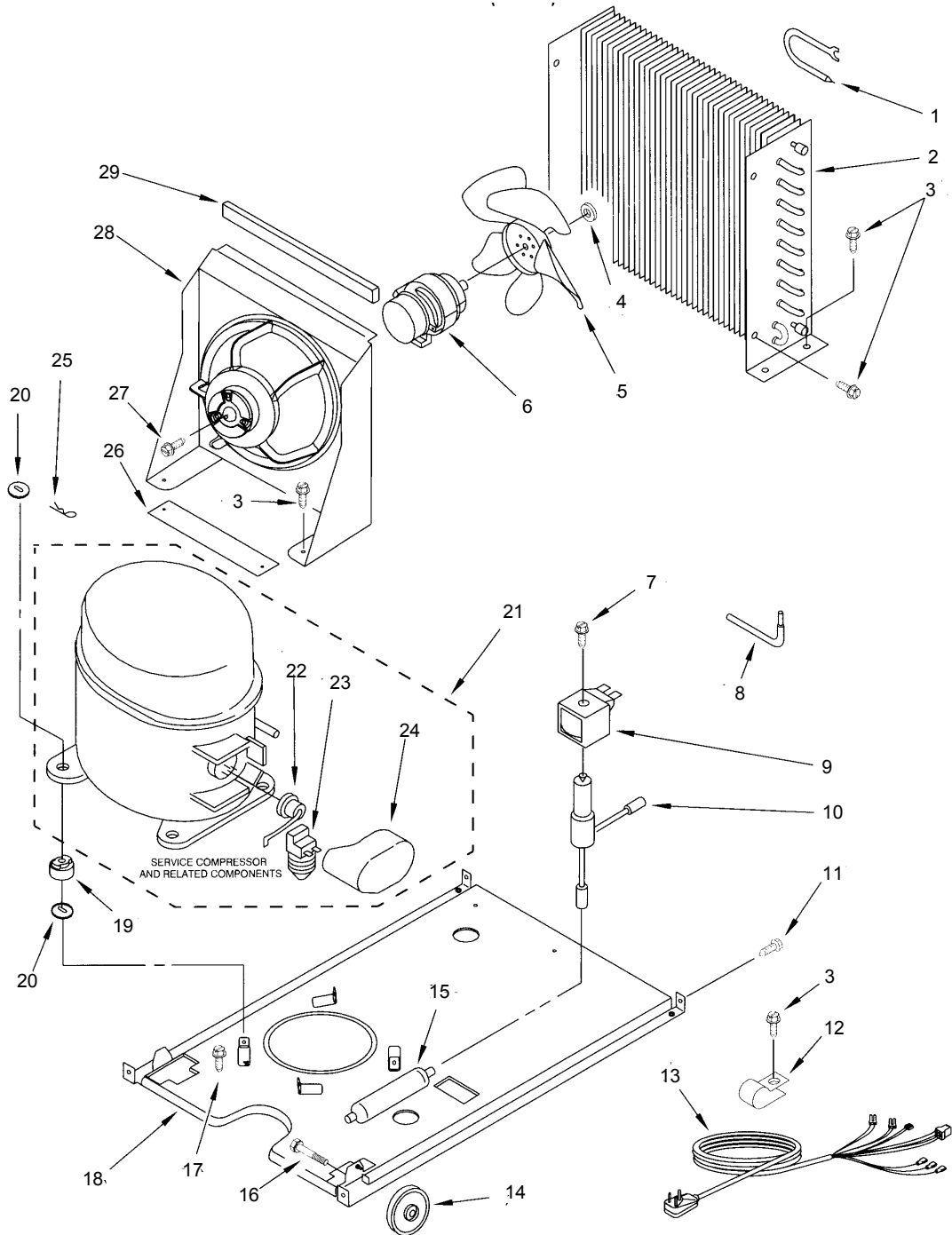

CSW45 Service Parts

Condensing Unit Parts

Item Number	Part Number	Description	Item Number	Part Number	Description
1	02180807	Accumulator	18	02185511	Base
2	02185529	Condenser	19	02185965	Grommet
3	0304392	Screw	20	08173859	Shim
4	0486692	Speed nut	21	04387773	"A" Series Compressor incl "A" 22, 23 and 24.
5	02190685	Fan blade			
6	04387244	Fan motor		04387964	"B-D" Series Compressor incl "B-D" 22, 23 and 24
7	0489472	Screw			
8	02185548	Process tube	22	02183404	"A" Series Overload
9	0759112	Hot gas valve coil		02217223	B-D Series Overload
10	0759113	Hot gas valve body	23	02183410	"A" Series Start relay
11	0489423	Screw		02217224	B-D Series Start relay
12	02185960	Clamp	24	02162358	"A" Series terminal cover
13	02185702	Wiring harness	25	08173857	Clip
14	0302819	Wheel	26	02185858	Pad
15	04387019	Dryer	27	0489494	Screw
16	03370389	Bolt	28	02185532	Fan motor bracket
17	0488868	Screw	29	02185675	Foam pad

CSW45 Service Parts

Control Panel

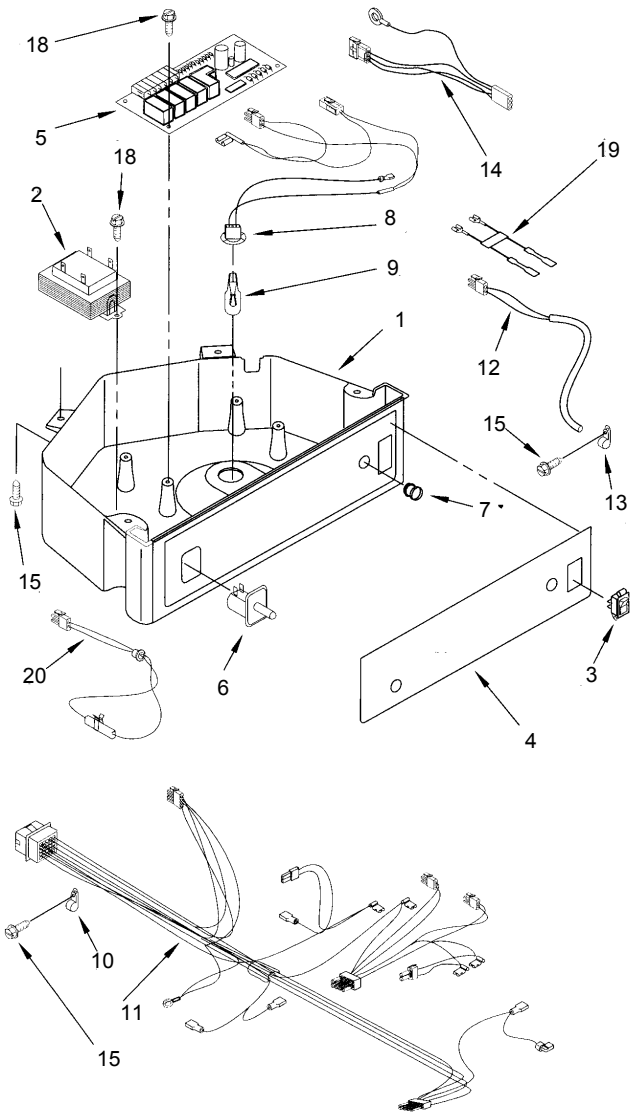

Item Number	Part Number	Description
1	02185867	Box, Control
2	02185657	Transformer
3	02185622W	Switch, Rocker
4	02185871W	Overlay
5	06100499	P.C. Board
6	02149705	Switch, Plunger
7	02185694	Lens, LED
8	02185692	Wiring Harness, Grid/ Light
9	0676304	Bulb
10	02185788	Clamp
11	02185589	Wiring Harness,Control Box
12	02217288	Thermostat, Bin
13	02185825	Clamp
14	02185703	Wiring Harness, Main to Pump
15	03400884	Screw 8-18 X 5/8
18	03400850	Screw 8-16 X 3/8
19	02185808	Wiring Harness,Rocker Switch
20	A38444-021	Thermister, Ice Control

CSW45 Service Parts Water System

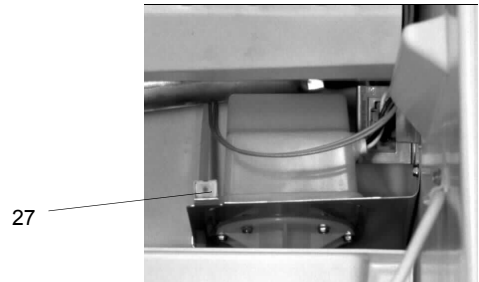
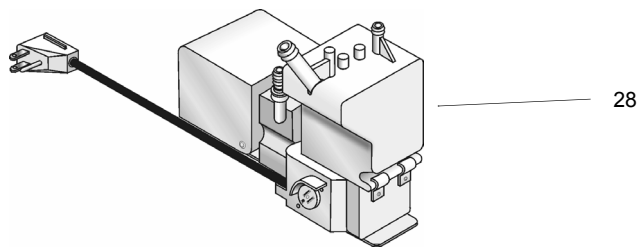
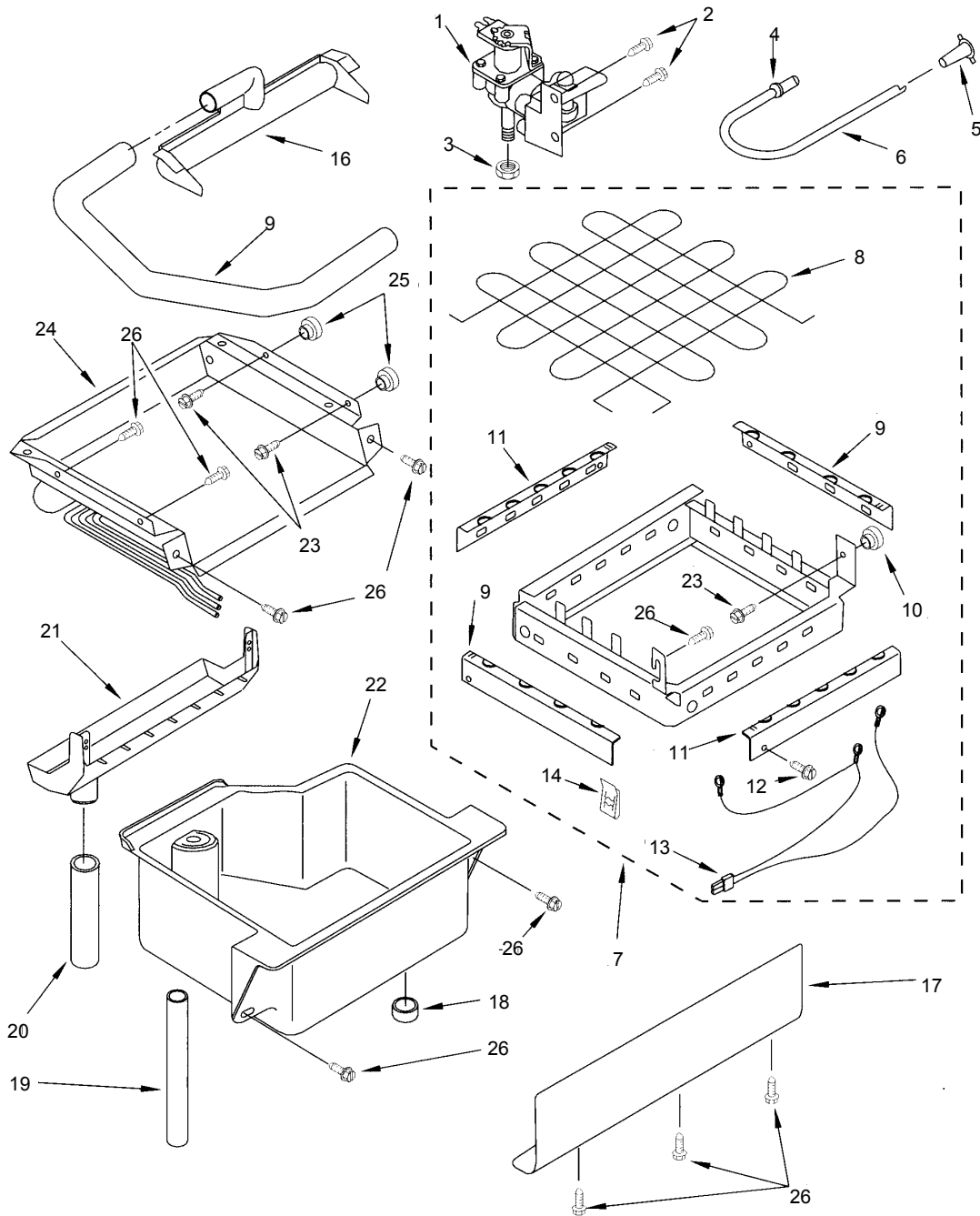

CSW45 Service Parts

Water System Parts

Item Number	Part Number	Description
1	W10139486	Valve, Complete Water
2	0488687	Screw 8-15 X 5/8
3	0627018	Nut, Compression
4	0487627	Sleeve, Compression
5	0841707	Insert, Tube
6	04387492	Tube, Water Fill
7	02313637	Grid Assembly (Complete)
8	04387020	Wire, Grid Cutter - order two
9	02217286	Tube, Plastic
10	0836667	Spacer
11	02185615	Bracket, Front and Rear
12	0489443	Screw
13	02185681	Harness, Grid
14	0488660	Nut, Speed
15	02185611	Bracket, Side Left and Right
16	02185523	Dispenser, Water
17	02185570	Cover, Grid
18	02185696	Cap, Drain
19	02185673	Hose, Overflow
20	02185626	Tube
21	02185625	Reservoir, Water Slide
22	02185624	Reservoir, Water
23	03400886	Screw 8-18 X 1 1/4
24	A38445-021	Evaporator
26	03400884	Screw 8-18 X 5/8
27	02217220	Water pump
28	A37649-001	Drain pump
	02208432	Drain pump hose
29	02217310	Ice guide

29



CSW45 Service Parts Schematic Diagram

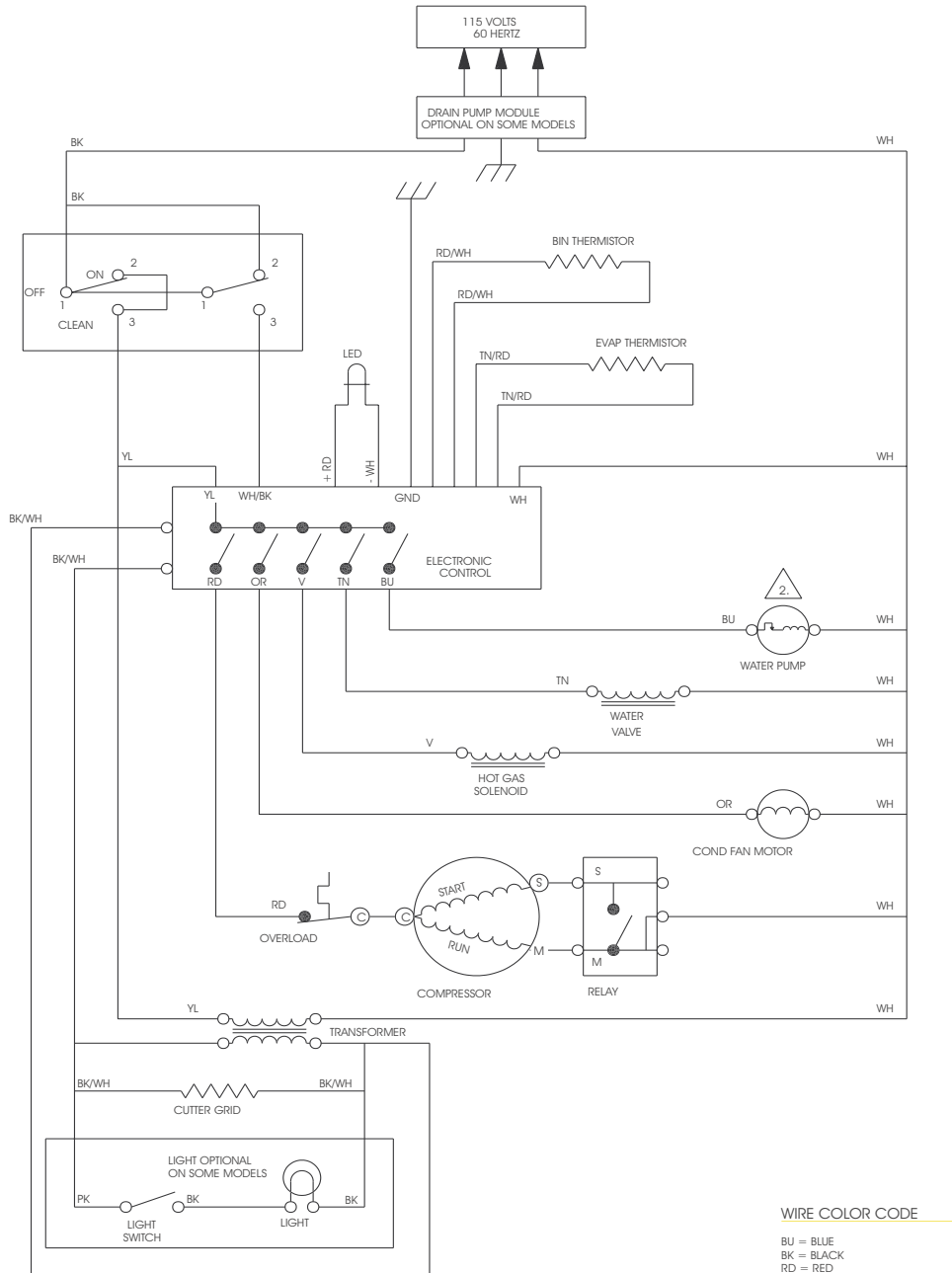

NOTE:
1. SOLENOID VALVE GROUNDED THROUGH MOUNTING.

2. FUSE IS INTERNAL TO MOTOR.

WIRE COLOR CODE

BU = BLUE
BK = BLACK
RD = RED
WH = WHITE
YL = YELLOW
OR = ORANGE
BR = BROWN
GY = GRAY
PK = PINK
V = VIOLET
TN = TAN
OR/BK = ORANGE/BLACK TRACER
Y/RD = YELLOW/RED TRACER
BU/BK = BLUE/BLACK TRACER
WH/BU = WHITE/BLUE TRACER
BK/YL = BLACK/YELLOW TRACER
WH/RD = WHITE/RED TRACER
GN/YL = GREEN/YELLOW TRACER
BK/WH = BLACK/WHITE TRACER
YL/BK = YELLOW/BLACK TRACER
RD/WH = RED/WHITE TRACER

SYMBOL CODE

⊙ = CONNECTOR - SCREW ON
⊗ = CONNECTOR - CLOSED END
○ = DISCONNECT TERMINAL
● = PERMANENT CONNECTION
➤ = PLUG CONNECTOR
⏏ = GROUND (CHASSIS)

CSW45 Service Parts

Wiring Diagram

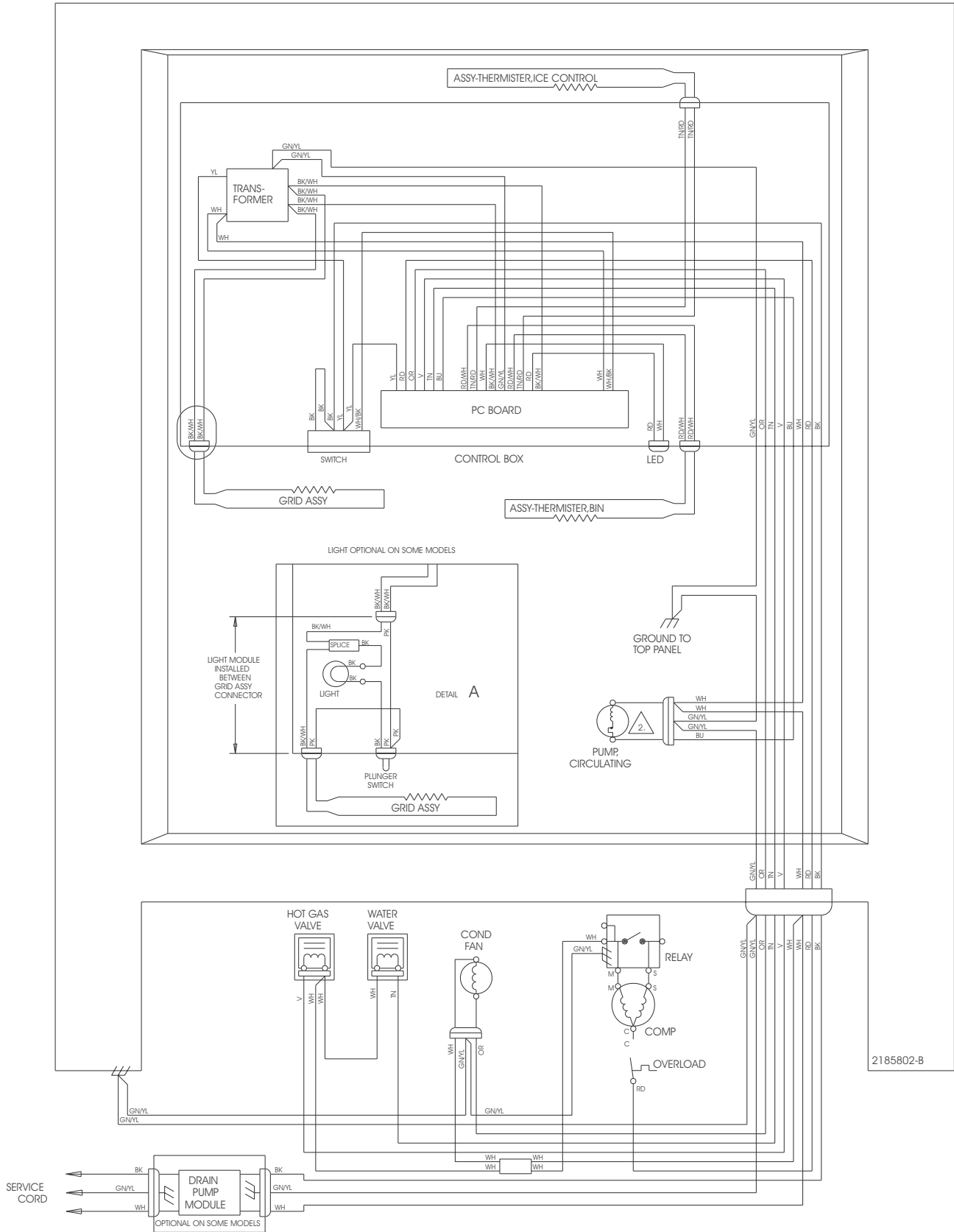

2185802-8