



IF 30

LIST OF THE EXPLODED VIEWS



SHELL ASSY

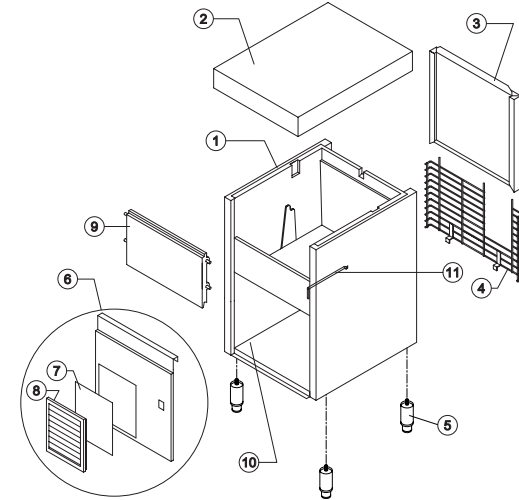

COOLING SYSTEM

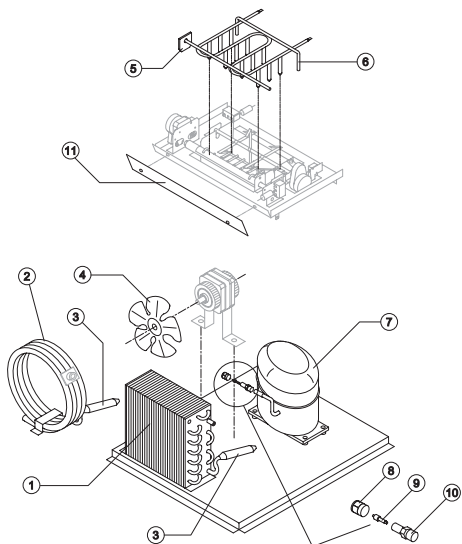

HYDRAULIC CIRCUIT

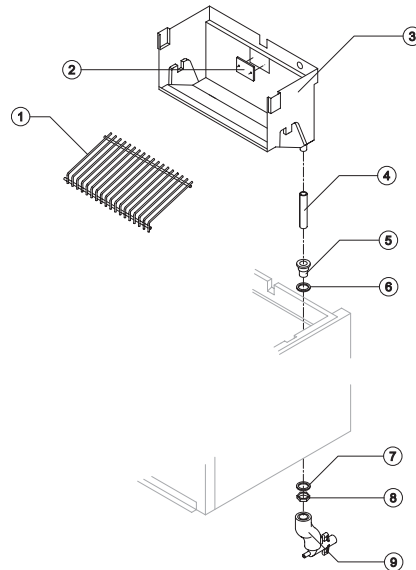

EVAPORATOR SUPPORT

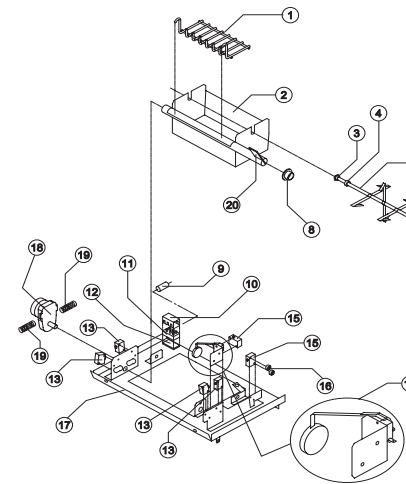

ELECTRIC PARTS

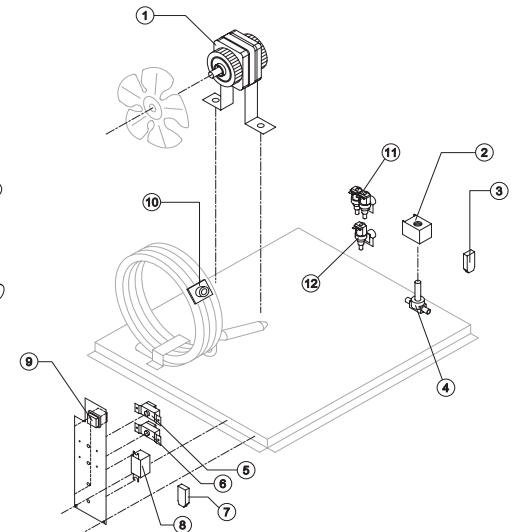

Rev. 4 - 20/10/2003

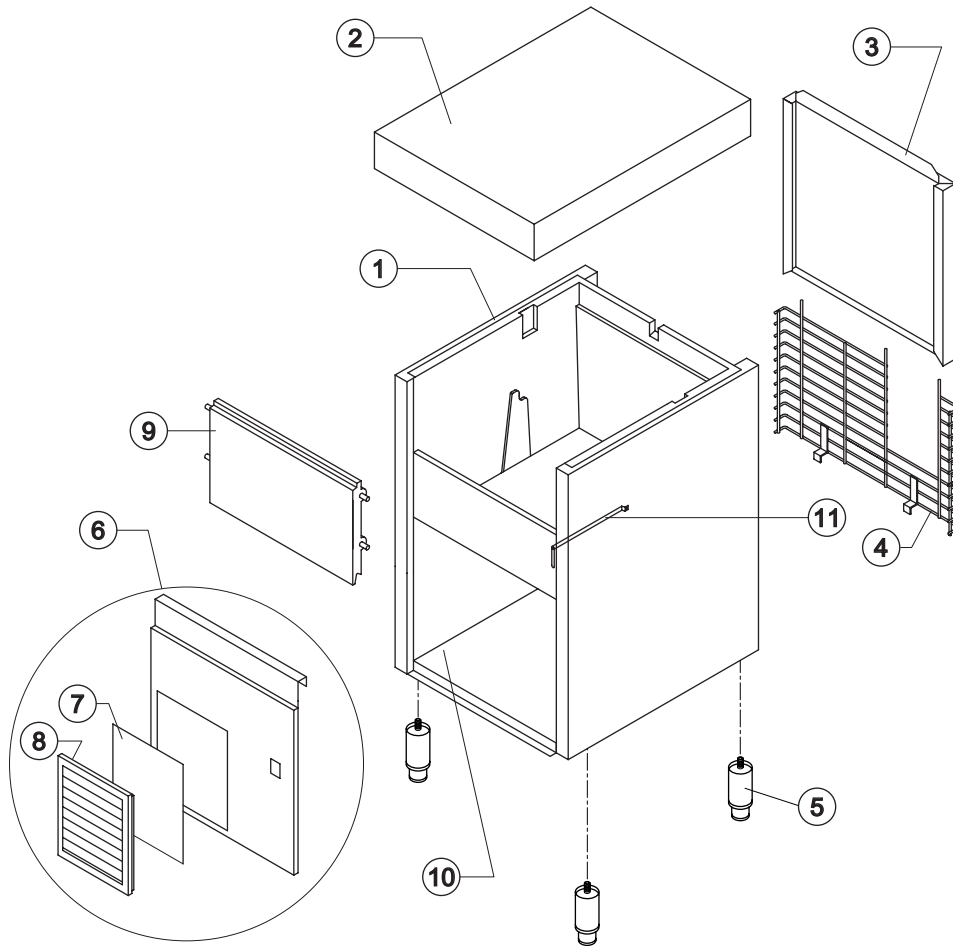

Ref.	Spare Description	Code
1	Foamed Cabinet Assy	C11035/E
2	Top Assembly	C22262
3	Back Panel Assembly	C26414
4	Rear Grid	D12006
5	Stainless Steel Foot Adjustable	Current Version 20613
5	ABS Foot	Till s/n. 141256 10040
6	Front Grid Panel	Current Version C22507
6	Front Panel	Till s/n. 31231 22012
7	Filtering Panel	18106
8	Frame with Grid & Filter	C10205
9	Door Assy	C10297
10	Base Plate	Current Version 21279
10	Base Plate	Till s/n. 141256 21013
11	Bulbe Thermostat Tube	Current Version 20522

Rev. 4 - 20/10/2003



IF 30

COOLING SYSTEM

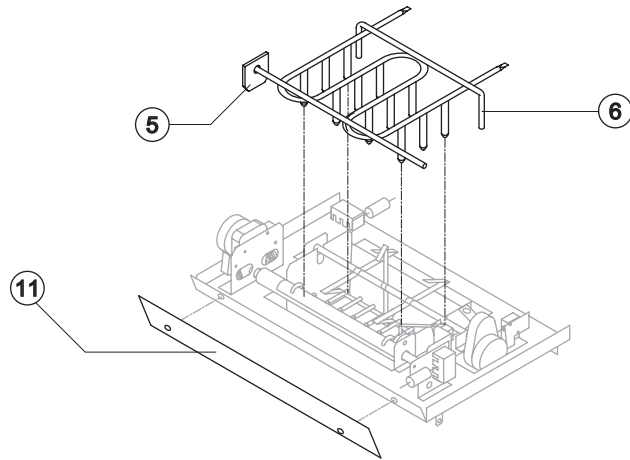

Common Parts

Ref.	Spare Description	Code
3	Molecular Drier	14009
5	Upright	22253
6	Evaporator	D14148
7	Compressor	See Table
8	Vaccum-Charge Valve Plug	14006
9	Vaccum-Charge Valve Device	14005
10	Vaccum-Charge Valve Body	14007
11	Protection Plate	10433

Parts for Air-Cooled Version Only

Ref.	Spare Description	Code
1	Air Condenser	20283
4	Suction Fan	20095

Parts for Water-Cooled Version Only

Ref.	Spare Description	Code
2	Water Condenser	See Note
4	Suction Fan	10213

Ref. 7 - Compressor

Tension	Code
220/240V 50 Hz	23436
220/230V 60 Hz	23494

! Ref. 2 - For s/n. before 104718 ask, besides the new Condenser (Code 14057) also the Fixing Bracket Code 21033.

Rev. 4 - 20/10/2003

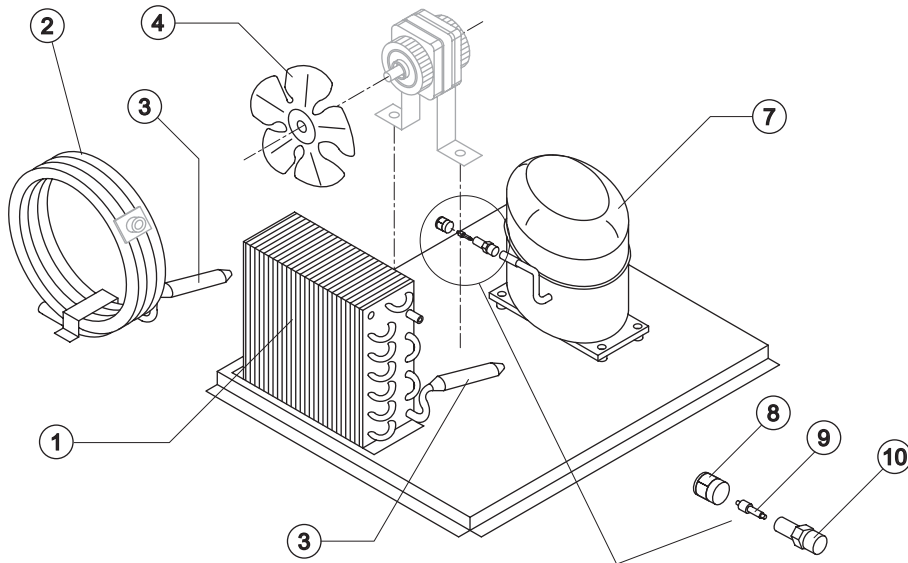



IF 30

HYDRAULIC CIRCUIT

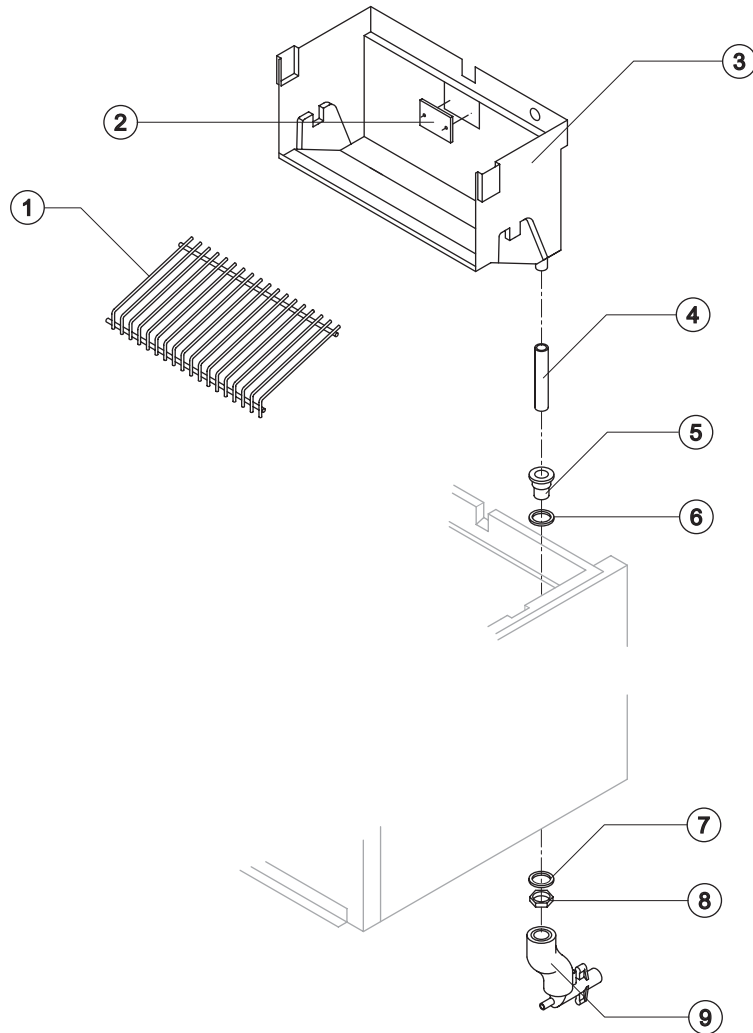

Common Parts

Ref.	Spare Description	Code
1	Ice Cubes Slide	D12042
2	Slide Keep Plate	10009
3	Inner Basin	10255
4	Overflow Pipe	Current Version 13107
4	Overflow Pipe	Till s/n. 64163 13053
5	Plastic Nipple Water Outlet	10007
6	Silicone Gasket	13006
7	Semirigid Polyethylene Gasket	13007
8	Bin Discharge Nut	10096

Parts for Air-Cooled Version Only

Ref.	Spare Description	Code
9	Discharges Manifold	C10006

Parts for Water-Cooled Version Only

Ref.	Spare Description	Code
9	Discharges Manifold	C26452

Rev. 4 - 20/10/2003



IF 30

EVAPORATOR SUPPORT

Rev. 4 - 20/10/2003

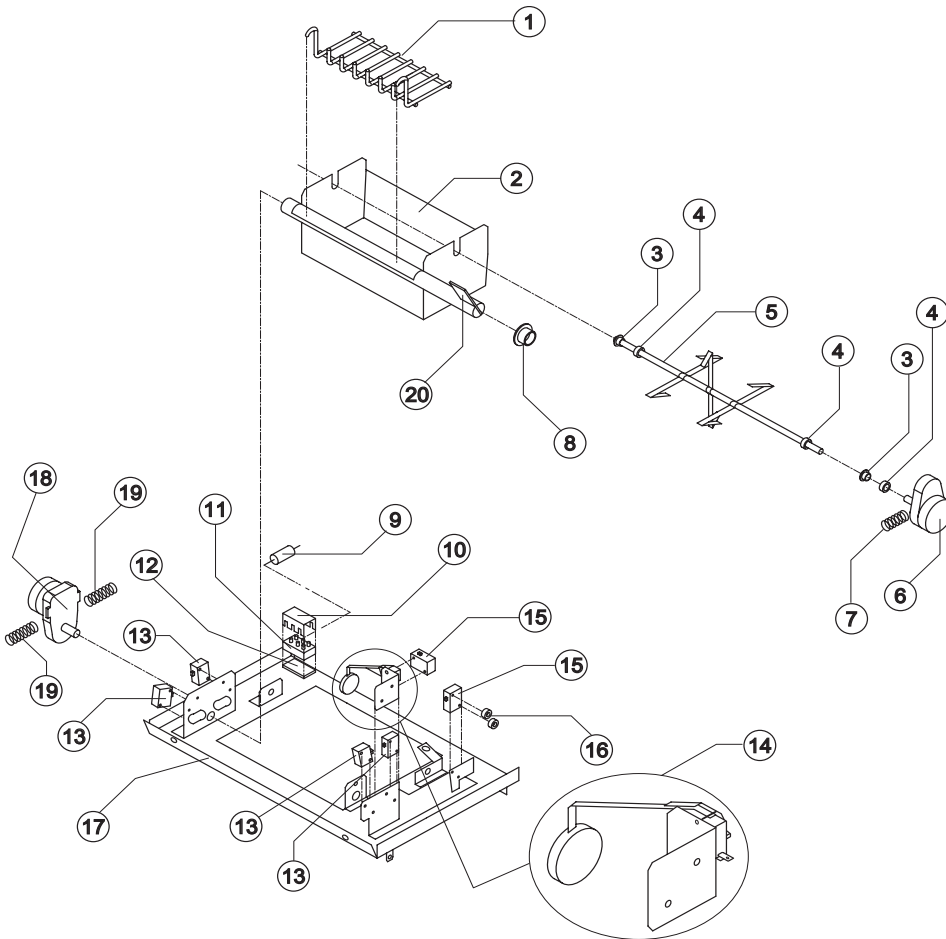

Ref.	Spare Description	Code	
1	Internal Tray Slide	D12043	
2	Water basin with Pin	C22256	
3	Self-Lubricating Bush 06/06	20230	
4	Shaft Stop Ring	20227	
5	Shaft with Paddles	20221	
6	Gearmotor (for Paddles)	23194	
7	Spring (Support Gearmotor)	20228	
8	Self-Lubricating Bush 12/07	20231	
9	Condenser 0,12 µF - 1000 V	220/240V 50 Hz	23318
9	Condenser 0,15 µF - 1000 V	220/230V 60 Hz	23329
10	Terminal Cover	23250	
11	Terminal	23249	
12	Terminal Board Spacer	10143	
13	Microswitch (usually closed)	23196	
14	Working Kit for the Floating Micro	C26562	
15	Microswitch (usually open)	23372	
16	Switch Shimming Ring	10250	
17	Evaporator Support Plate	22260	
18	Gearmotor (for Turnover Basin)	See Table	-
19	Spring (Support Gearmotor)	20232	
20	Micro-Finger Connecting Link	22258	

! The Complete Evaporator Support Plate has to be requested, making reference to the Table.

Ref. 18 - Gearmotor (for Turnover Basin)

Tension	Code
220/240V 50 Hz	23195
220/230V 60 Hz	23581

Evaporator Support Plate

Tension	Code
220/240V 50 Hz	C22260
220/230V 60 Hz	C22727

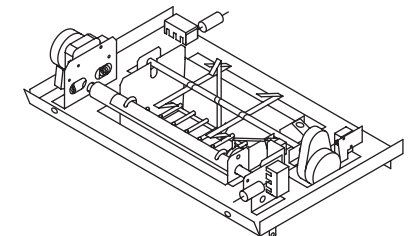



IF 30

ELECTRIC PARTS

Common Parts

Ref.	Spare Description	Code
1	Fan Motor	23029
2	Hot Gas Coil	23091
3	Anti Radio Interference Filter 220-240V 50 Hz	23458
4	Hot Gas Valve Body	20410
5	Condenser Pressure Switch	23175
6	Bin Thermostat	23005
7	Anti Radio Interference Filter 220-240V 50 Hz	23459
8	Relay	23190
9	Green Light Switch	23327

Parts for Air-Cooled Version Only

Ref.	Spare Description	Code
12	Inlet Watervalue 1 Way	23220

Parts for Water-Cooled Version Only

Ref.	Spare Description	Code
10	Safety Thermostat	C23114
11	Inlet Watervalue 2 Ways	23501

Rev. 4 - 20/10/2003

