

DISHWASHER

ELECTROMECHANICAL SWITCHES
LOWER AND UPPER WASHING

TYPE: LUX60

Accessories
BREAK TANK
BOOSTER PUMP
DVGW
COLD RINSE
WATER SOFTNER
DETERGENT DISPENSER
DRAIN PUMP

Spare parts manual

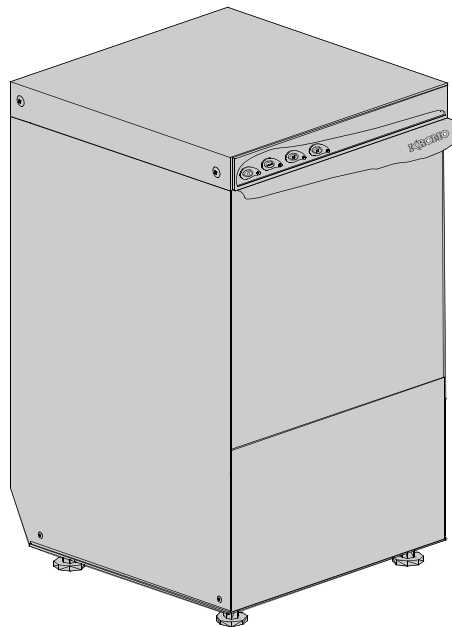

Parti di ricambio Spare Parts Catalogues pièces

INFORMAZIONI GENERALI

Questo catalogo serve per richiedere con esattezza le parti di ricambio

Nelle ordinazioni indicare:

1) il numero dei codici dei particolari seguito dalla descrizione e la quantità desiderata;

2) Il codice alfa-numeric presente nella seconda colonna della tabella ;

I disegni delle parti di ricambio sono solo indicativi e non rappresentano il pezzo in oggetto.

I dati contenuti in questo catalogo sono indicativi e possono essere soggetti a modifiche senza impegno di preavviso.

ALLGEMEINE INFORMATIONEN

Dieser Ersatzteilkatalog dient zur genauen Angabe der Teile bei Ersatzteilbestellungen.

Bei Ersatzbestellung ist folgendes anzugeben:

1) Die Bestellnummer der Ersatzteile mit der entsprechenden Beschreibung genaue Menge;

2) Der alpha-numerischer Code auf der zweiten Reihe in dein Spalte;

Die Zeichnungen der Ersatzteile sind nur als Hinweise gedacht und stellen nicht das betroffene Teil dar.

Bei den im Katalog angeführten Daten handelt es sich um Anhaltsdaten, die jederzeit, ohne Vorankündigung, geändert werden können.

GENERAL INFORMATION

The present spare parts order exactly the right spare parts

When ordering specify:

1) the part's code number followed by its description and quantity needed;

2) The alpha-numeric code is in the second column in the chart;

Spare parts drawings are general and do not represent the part.

The contents of this catalogue are general and can undergo changes without prior notice.

INFORMACIONES GENERALES

El presente catálogo sirve para pedir con exactitud las partes de repuesto

En los pedidos se debe indicar:

1) el número de código de la parte y a continuación la descripción cantidad deseada;

2) El código alfanumerico presente en la signada columna de la tabla;

Los diseños de las partes de recambio son solo indicativos y no representan la pieza en cuestión.

Los datos contenidos en el presente catálogo son indicativos y pueden modificarse sin aviso previo.

INFORMATIONS GENERALES

Ce catalogue permet de commander correctement les pièces détachées

Les commandes doivent être passées en indiquant:

1) le numero de code des pièces détachés suivi de leur description quantité désirée;

2) le code alphanumérique dans la deuxième colonne du tableau;

Les plans des pièces détachées sont fournis seulement à titre indicatif et ne représentent pas la pièce concernée.

Les données de ce catalogue sont citées seulement à titre indicatif et peuvent être l'objet de modifications sans avis préalable.

ESEMPIO EXAMPLE EXEMPLE BEISPIEL

Rif.	Codici
MODULE:Particolari	
10505	540903
10510	540908
10515	15065/A
10520	540086
10525	540028

Note

Tutte le informazioni riportate si intendono aggiornate alla data di stampa. Il Produttore si riserva il diritto di apportare qualsiasi modifica richiesta dallo sviluppo evolutivo dei suddetti prodotti.

Per la sicurezza, la garanzia, l'affidabilità ed il valore della lavastoviglie usa solo ricambi originali.

Attenzione

Questo libretto è parte integrante della lavastoviglie e, in caso di passaggio di proprietà, deve essere consegnato al nuovo acquirente.

Note

The information contained herein is valid at the time of going to print. The Company reserves the right to make any changes required by the future development of the above-mentioned products.

For your safety, as well as to preserve the warranty reliability and worth of your dishwashers, use original spare parts only.

Warning

This manual forms an integral part of the dishwashers and - if a transfer of title occurs - must always be handed over to the new owner.

Remarque

Toutes les informations contenues dans ce manuel s'entendent mises à jour à la date d'impression. En raison du développement constant de ses produits, usine se réserve le droit d'apporter à tout instant les modifications qu'elle jugera utiles.

Pour la sécurité, la garantie, la fiabilité et la valeur de votre lave-vaisselles n'utilisez que des pièces de rechange d'origine.

Attention

Ce manuel doit être considéré comme partie intégrante de la lave-vaisselles, en cas de transfert de propriété, doit toujours être remis au nouveau propriétaire.

Hinweis

Die Der Hersteller behält sich das Recht vor, jegliche, durch eine Weiterentwicklung der genannten Produkte bedingte Änderungen vornehmen zu können.

Verwenden Sie für Ihre Sicherheit, die Garantie, die Zuverlässigkeit und den Wert Ihrer machine originale Ersatzteile.

Achtung

Diese Betriebsanleitung ist Bestandteil des machine und muss bei seinem Weiterverkauf dem neuen Besitzer ausgehändigt werden.

1. Spare parts

General body parts.....	7
Lockup system	9
Control panel and switches.....	11
Electric control components.....	13
Solenoid valve group	15
Solenoid valve group	17
Break Tank	19
Booster pump.....	21
DVGW	23
Water softner group.....	25
Rinse aid dispenser group.....	27
Rinse aid dispenser group.....	29
Boiler group	31
3 ways connection	33
Wash pump	35
Dosing detergent group.....	37

Dosing detergent group.....	39
Drain pump group.....	41
Pressure switch group with air trap ...	43
Turret group with rotating arms	45

1.1 Voltage codes

Voltage code	Voltage
A	3/N/PE~400/230V 50Hz
B	~250V 16A 50Hz
C	3/N/PE~380/220V 50Hz
D	3/PE~200V 50-60Hz
F	2/PE 220-240V 50Hz
G	3/N/PE~415/240V 50Hz
H	3/PE~230V 50Hz
I	3/PE~220V 60Hz
J	3/PE~380 50Hz
K	3/PE~400V 50Hz
L	3/PE~415V 50Hz
M	3/PE~440V 60Hz
N	3/PE~460V 60Hz
O	3/PE~480V 60Hz
P	1/N/PE~220-240V 50Hz
R	2/PE~220-230V 60Hz
S	3/N/PE~400/230V 50Hz
T	3/PE~230V 60Hz

1.2 Product codes

Product code	Full name
Model codes	
em	ELECTROMECHANICAL SWITCHES
ls	LOWER AND UPPER WASHING
Type codes	
LUX60	LUX60
Accessory codes	
bt	BREAK TANK
pap	BOOSTER PUMP
dvgw	DVGW
fs	COLD RINSE
d	WATER SOFTNER
dde	DETERGENT DISPENSER
ps	DRAIN PUMP

01_002_e

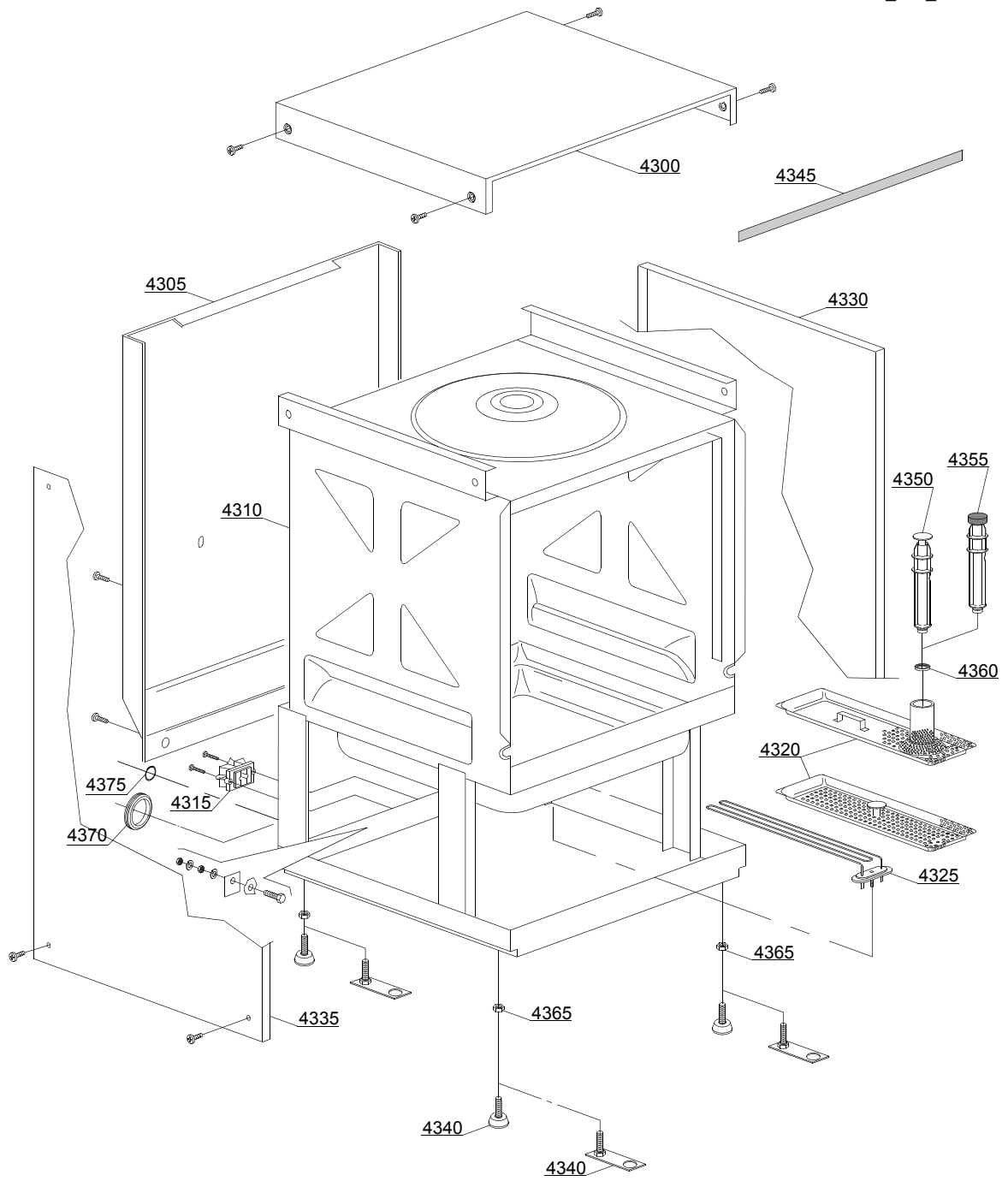

Spare parts

ID	P-code	Model	Type	Accessory	Voltage	Description
MODULE:General body parts						
4300	560917		LUX60			Cover
4305	560919		LUX60			Back panel
4305	560938		LUX60	bt		Back panel
4310	560900		LUX60			Body
4310	560928		LUX60	ws		Body
4315	15065/A		LUX60			Cable-fastener with screw
4320	560925		LUX60			Surface filter
4325	150047		LUX60			2,7/2,94KW 230/240V heating element
4325	150047/A		LUX60			2,7KW heating element
4330	560914		LUX60			Right side
4335	560915		LUX60			Left side
4340	10786		LUX60			M10x25 Ø40 black foot
4340	15176		LUX60			M10 marina foot
4345	560021		LUX60			Profile for door O-ring
4350	500619		LUX60			Overflow pipe
4355	560020		LUX60	dp		Overflow pipe
4360	13021		LUX60			DEM 40 O-ring
4365	11711		LUX60			M10 zinc plated nut
4370	13317		LUX60			Ø40mm lead through rubber
4375	13323		LUX60			Ø13mm lead through rubber

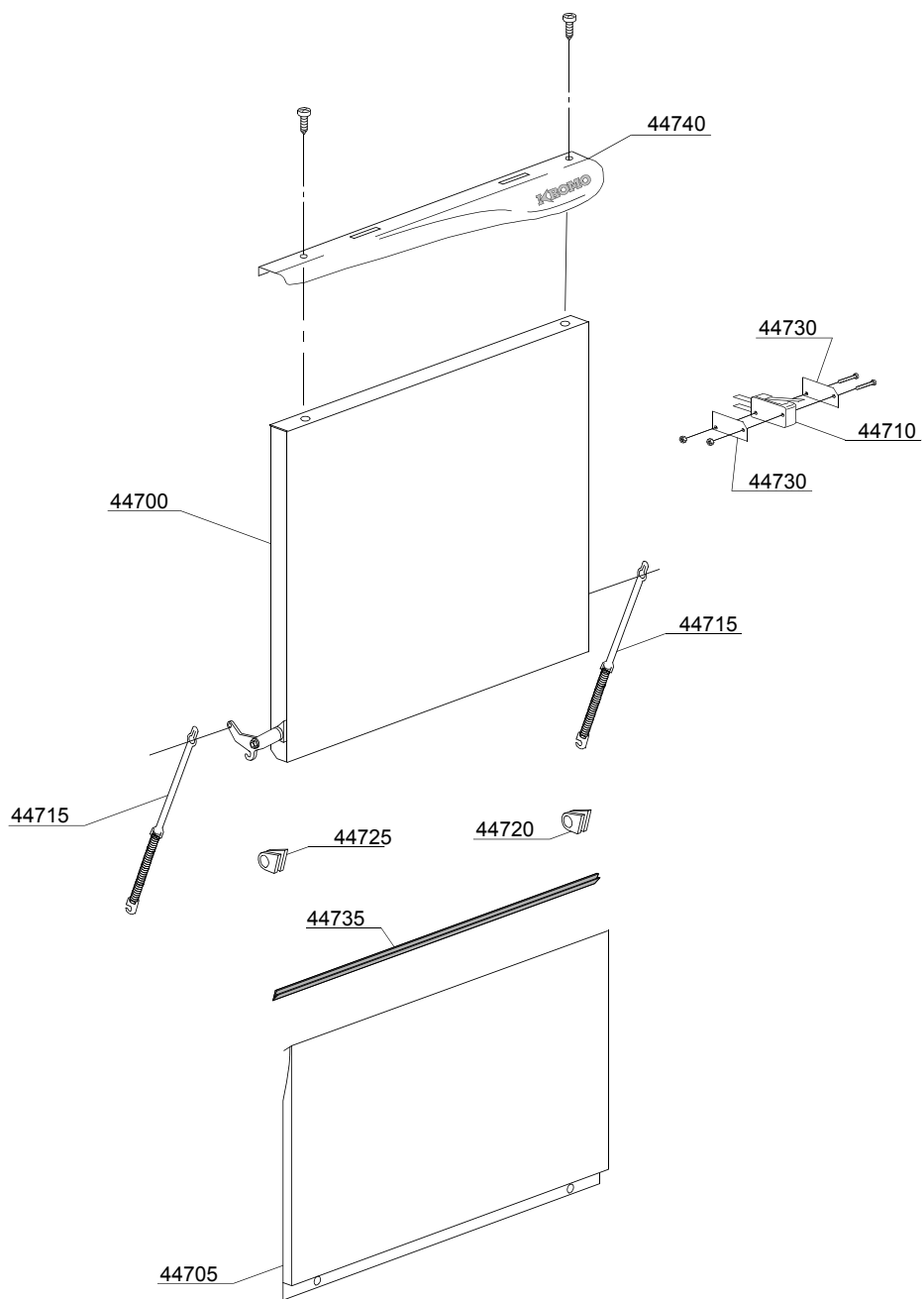

02_128_e

ID	P-code	Model	Type	Accessory	Voltage	Description
MODULE:Lockup system						
44700	560963		LUX60			Door with steel handle
44705	560920		LUX60			Lower door
44710	10704		LUX60			Door microswitch
44715	560003		LUX60			Door spring
44720	560006		LUX60			Right lock for door hinge
44725	560007		LUX60			Left lock for door hinge
44730	10770		LUX60			Insulation for door microswitch
44735	560013		LUX60			Profile for lower-door O-ring
44740	560965		LUX60			Stainless steel handle

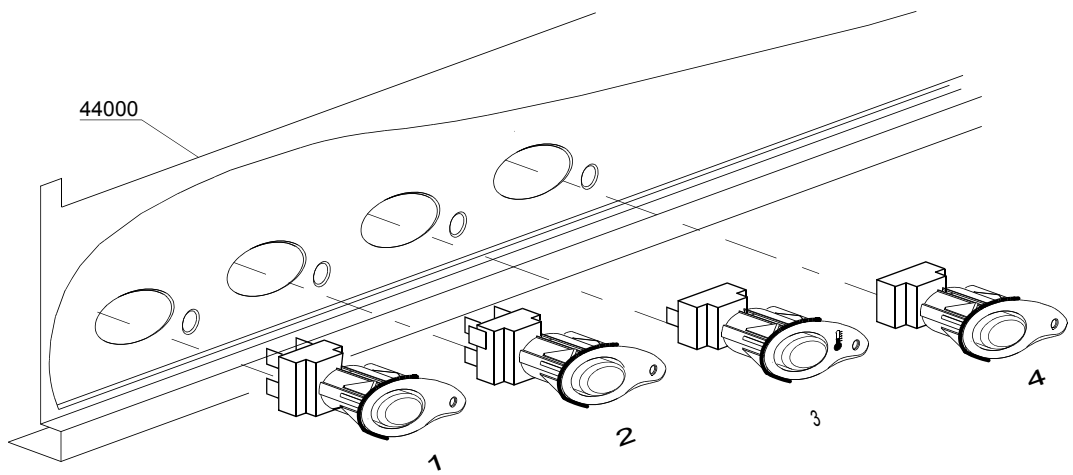

03_053_e

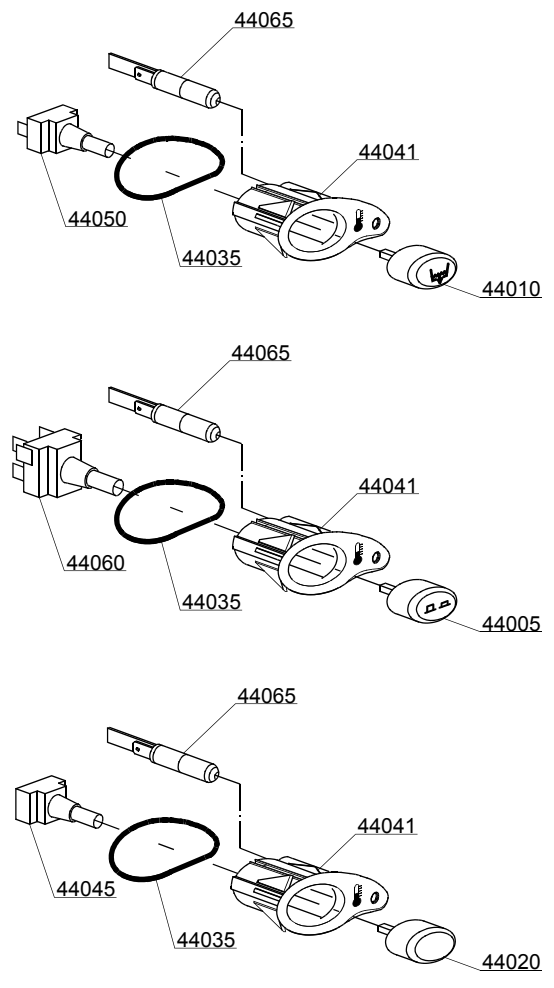
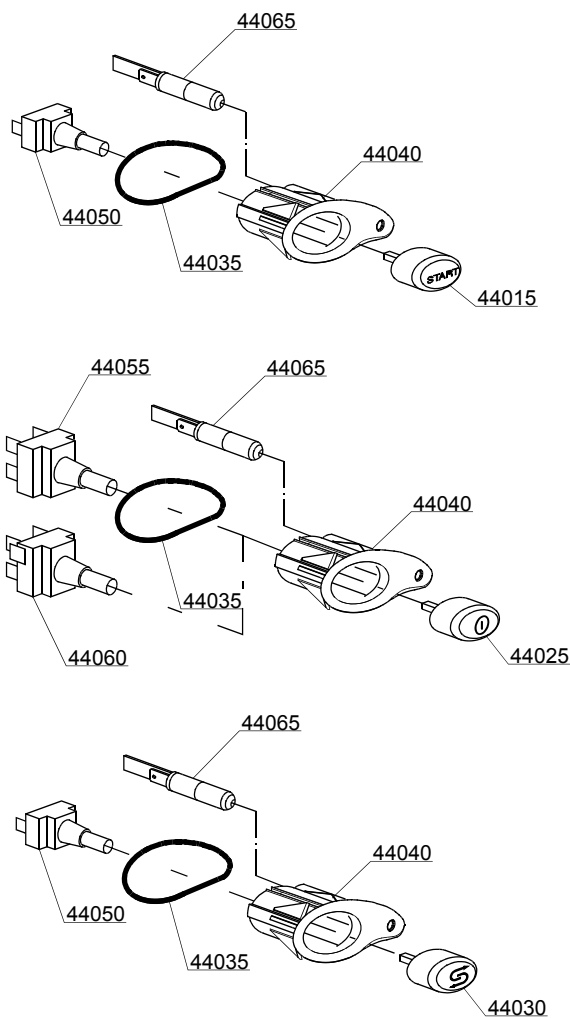

Spare parts

ID	P-code	Model	Type	Accessory	Voltage	Description
MODULE:Control panel and switches						
44000	560966		LUX60			Control panel LUX60
44005	89342		LUX60	cr		Time selector switch push button
44010	89343		LUX60	dp		Drain pump push button (OPTIONAL)
44015	89341		LUX60			START push button
44020	89348		LUX60			Blind push button
44025	89340		LUX60			ON-OFF push button
44030	89345		LUX60	ws		Regeneration push button (OPTIONAL)
44035	86006		LUX60			OR O-ring
44040	86001		LUX60			Push button support
44041	86002		LUX60			Temperature push button support
44045	15844		LUX60			Push button support
44050	15813		LUX60			16A unipolar switch
44055	15812		LUX60			16A bipolar switch
44055	15800		LUX60			16A switch
44060	15811		LUX60			16A bipolar switch
44060	15811/A		LUX60			16A bipolar switch
44065	15826		LUX60			Pilot light 220V

04_003_e

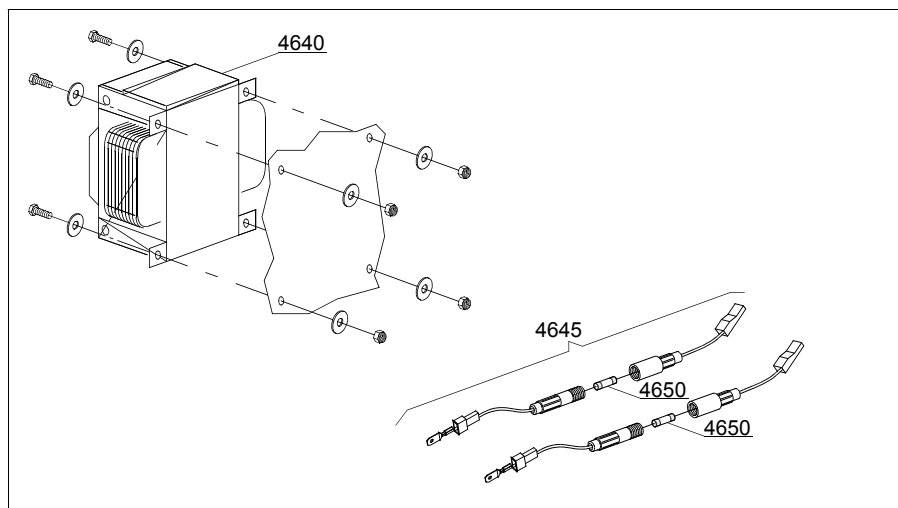
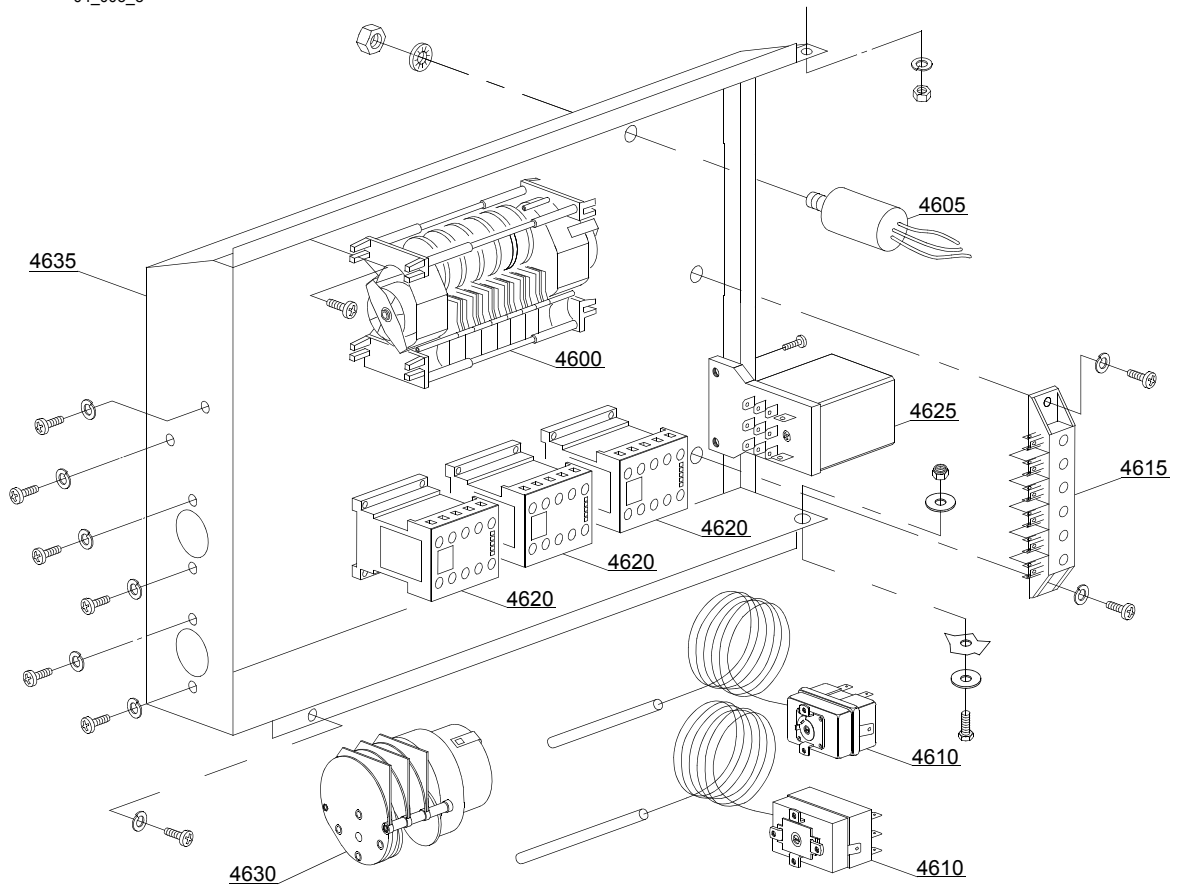

Spare parts

ID	P-code	Model	Type	Accessory	Voltage	Description
MODULE:Electric control components						
4600	10300123		LUX60		A	90/180" timer
4600	30001027		LUX60		A	120/180" timer
4600	30001028		LUX60			120/180" timer - 60Hz"
4600	22011/A		LUX60		A	120/240" timer
4600	30001031		LUX60		A	120/180" timer with thermostop
4600	30001032		LUX60			120/180" - 60Hz timer with thermostop
4600	30001030		LUX60			120/240" timer with thermostop
4605	15146		LUX60			Low noise filter
4605	15149		LUX60			Low noise filter
4605	15187		LUX60			Low noise filter
4610	10707/1		LUX60			0-90°C thermostat
4615	500551		LUX60			6 poles terminal board
4620	15086		LUX60			Contactora 230V 50/60Hz 4C
4620	15086/B		LUX60			Contactora 240V 50Hz
4620	15086/T		LUX60			200Vac3N 50/60HZ contactora
4625	16037/D		LUX60	ws		16A bipolar relay
4625	15620		LUX60	ws		16A bipolar relay
4630	16064/A		LUX60	ws		Regeneration timer
4635	560921		LUX60			Electric components panel
4640	15381		LUX60			160Va transformer
4645	15147		LUX60			Fuse-holder
4650	15163		LUX60			Fuse

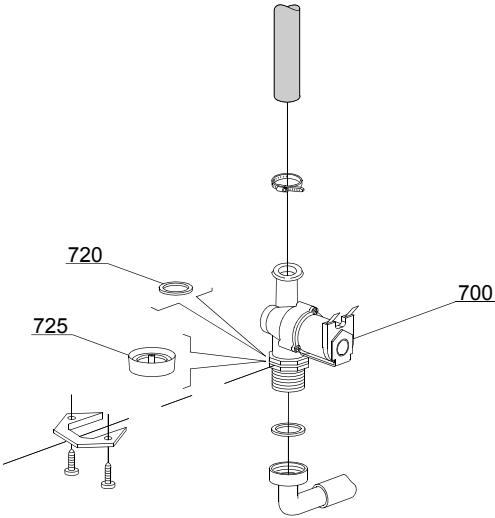

05_002_e

Spare parts

ID	P-code	Model	Type	Accessory	Voltage	Description
MODULE: Solenoid valve group						
700	10703		LUX60			Single solenoid valve
720	N.C.		LUX60			Pression reducing valve

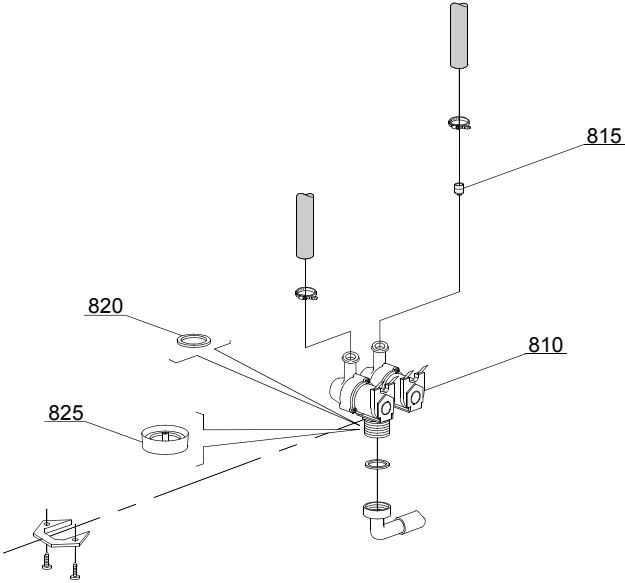

05_003_e

Spare parts

ID	P-code	Model	Type	Accessory	Voltage	Description
MODULE: Solenoid valve group						
810	15098		LUX60	cr,ws		Double solenoid valve - Ø10
815	15115		LUX60	cr,ws		Green pression solenoid valve
820	N.C.		LUX60	cr,ws		Pression reducing valve

06_004ae

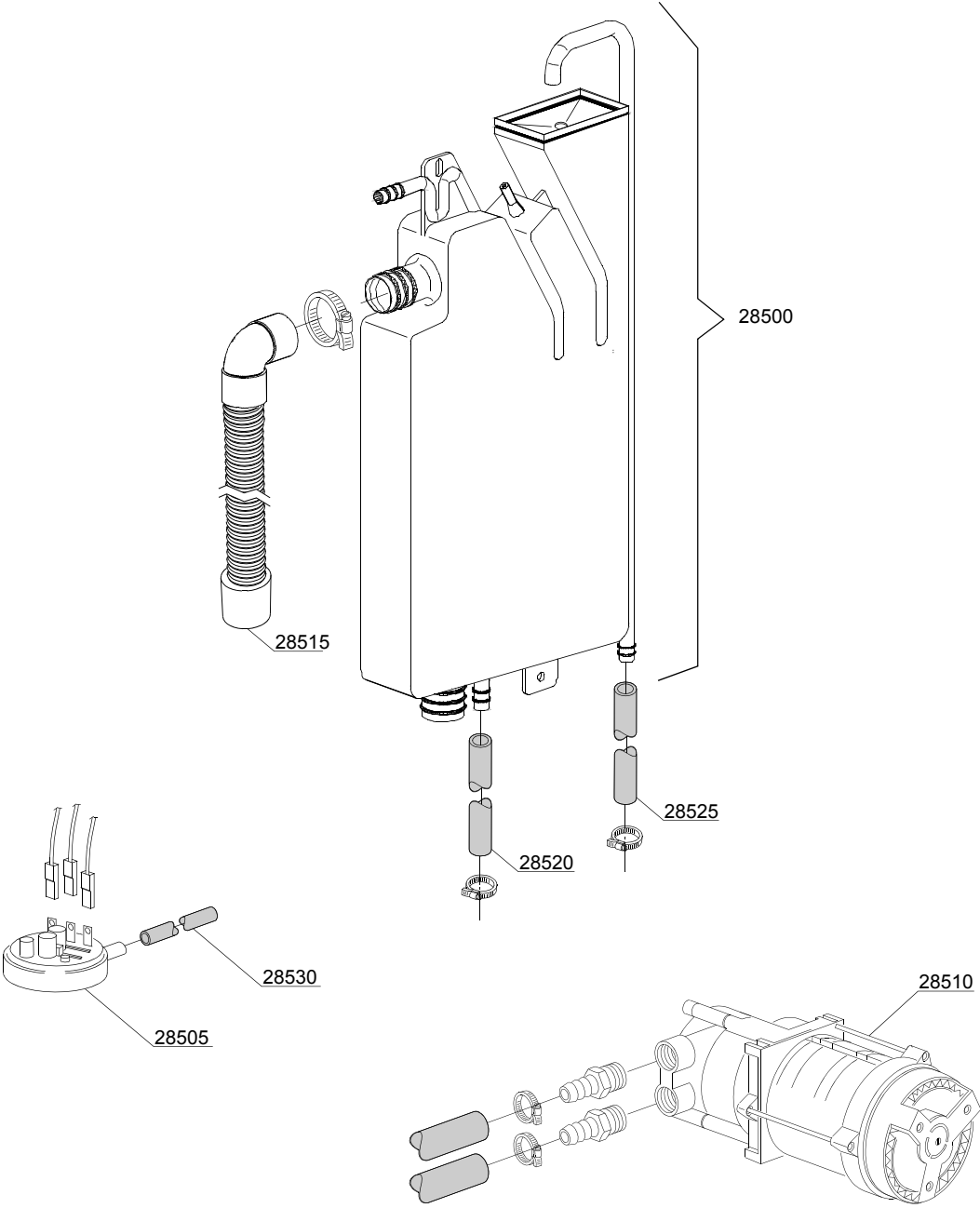

Spare parts

ID	P-code	Model	Type	Accessory	Voltage	Description
MODULE:Break Tank						
28500	15735		LUX60	bt		Break tank assembly
28505	10706/A		LUX60	bt		47-27 pressure switch
28510	15100/D		LUX60	bt		Booster pump 220-240/50
28515	15721		LUX60	bt		BT long pipe L=1070
28515	15722		LUX60	bt		BT middle pipe L=920
28515	15723		LUX60	bt		BT small pipe L=920
28520	2907350		LUX60	bt		12x20 EPDM rubber hose
28525	2907352		LUX60	bt		PVC WRAS rubber hose
28530	14508		LUX60	bt		4,5x9 EPDM rubber hose

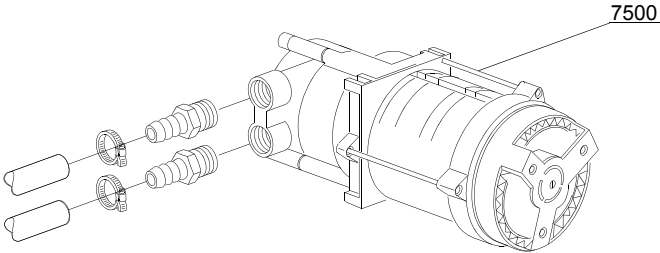

07_003_e

Spare parts

ID	P-code	Model	Type	Accessory	Voltage	Description
MODULE:Booster pump						
7500	15100/D		LUX60	bp		Booster pump 220-240/50

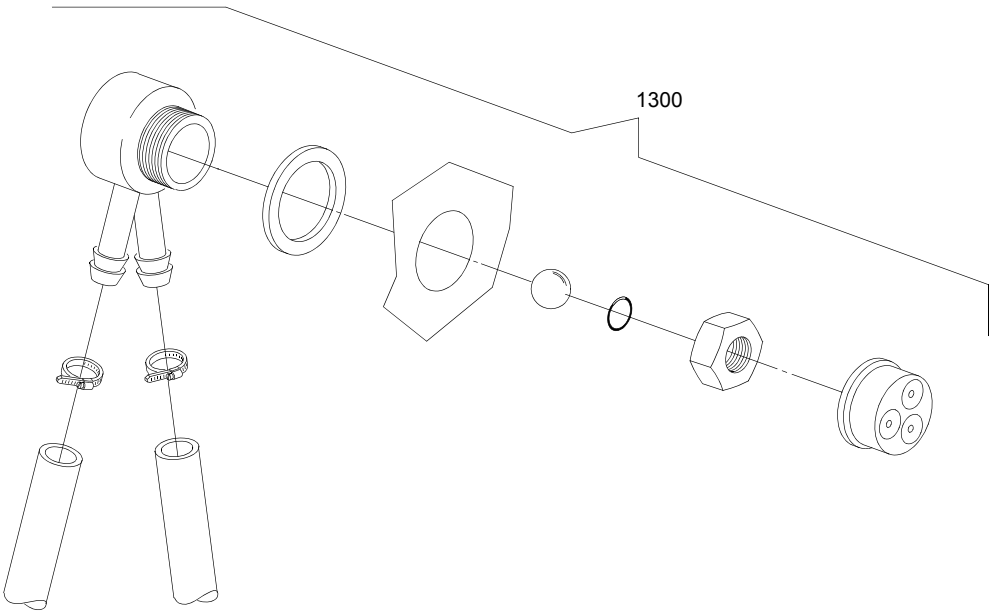

08_005_e

Spare parts

ID	P-code	Model	Type	Accessory	Voltage	Description
MODULE:DVGW						
1300	999900006		LUX60	dvgw		DVGW assembly

09_001_e

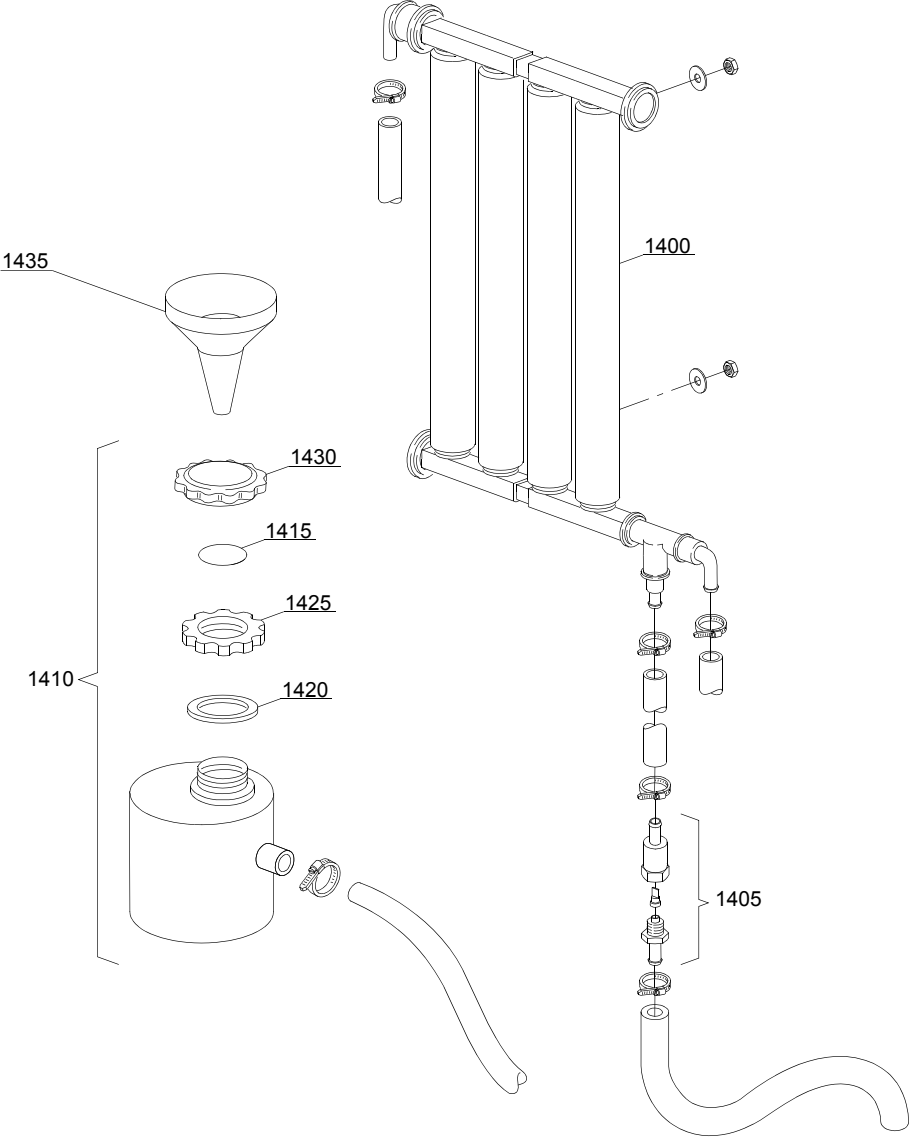

Spare parts

ID	P-code	Model	Type	Accessory	Voltage	Description
MODULE:Water softner group						
1400	16066		LUX60	ws		4 elements water softner
1405	16070		LUX60	ws		Nonreturn valve
1410	16065		LUX60	ws		Salt container
1415	16067/A		LUX60	ws		OR O-ring
1420	16067/B		LUX60	ws		O-ring
1425	16067/C		LUX60	ws		Ring nut
1430	16067/D		LUX60	ws		Plug
1435	16082		LUX60	ws		Funnel

10_002_e

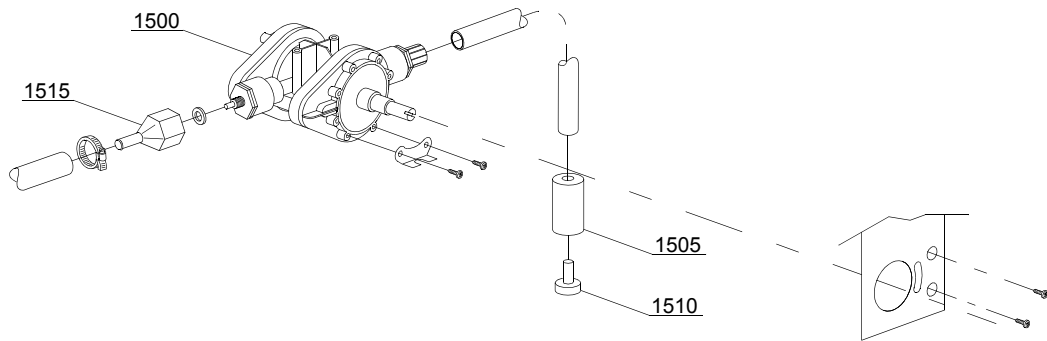

Spare parts

ID	P-code	Model	Type	Accessory	Voltage	Description
MODULE: Rinse aid dispenser group						
1500	10798		LUX60			Rinse aid dispenser
1505	12525		LUX60			Counter-weight
1510	15058		LUX60			Small filter
1515	10798/B		LUX60			Brass pipe fitting

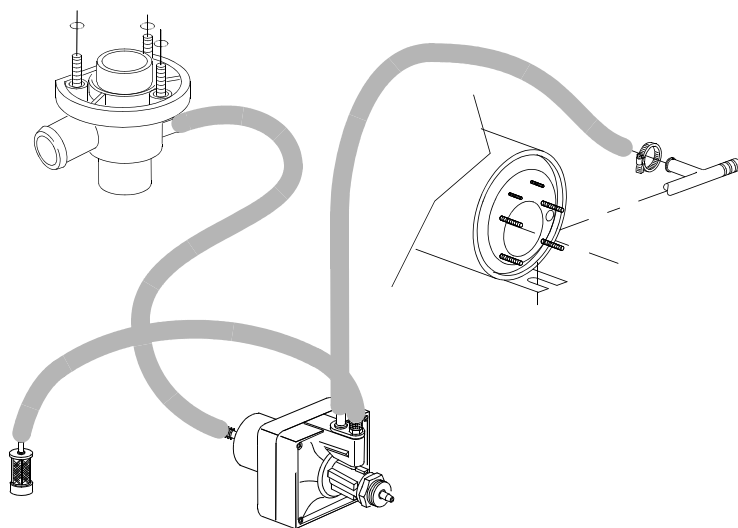
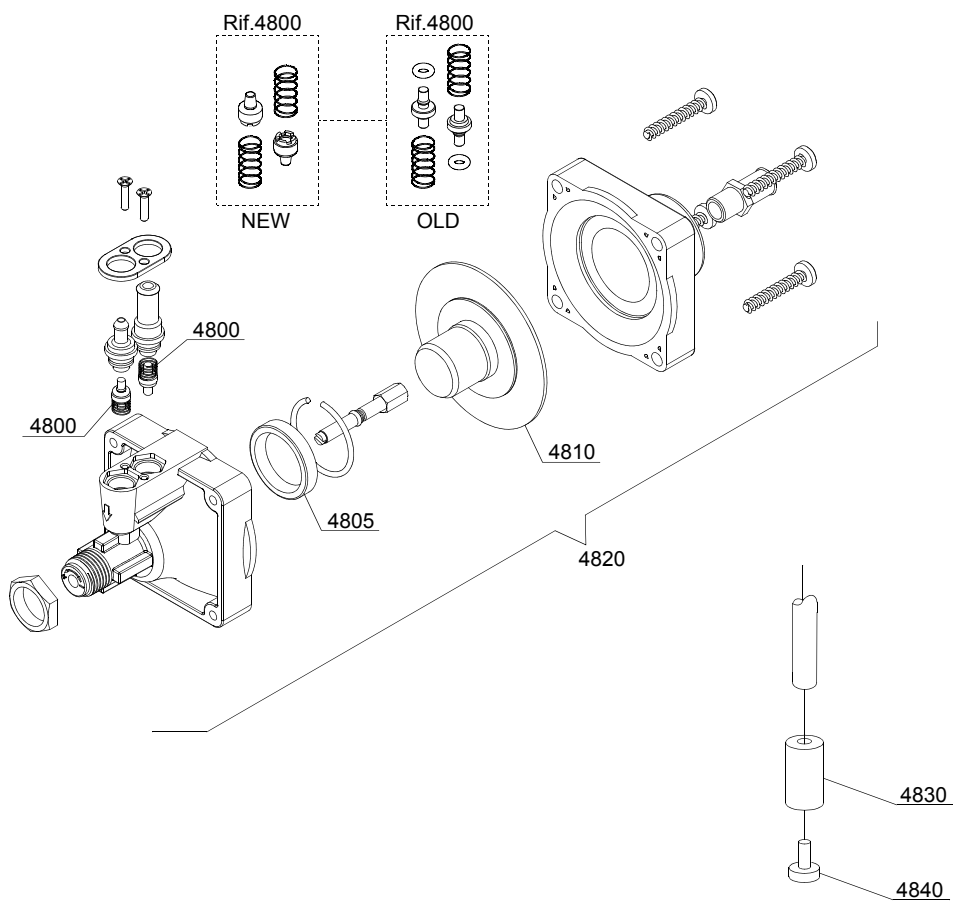

10_004_e

Spare parts

ID	P-code	Model	Type	Accessory	Voltage	Description
MODULE: Rinse aid dispenser group						
4800	10805		LUX60			Tecno pro non return valve
4805	10806		LUX60			Ø22 O-ring
4810	10807		LUX60			Membrane
4820	10799		LUX60			Rinse aid dispenser
4830	12525		LUX60			Counter-weight
4840	15058		LUX60			Small filter

11_002_e

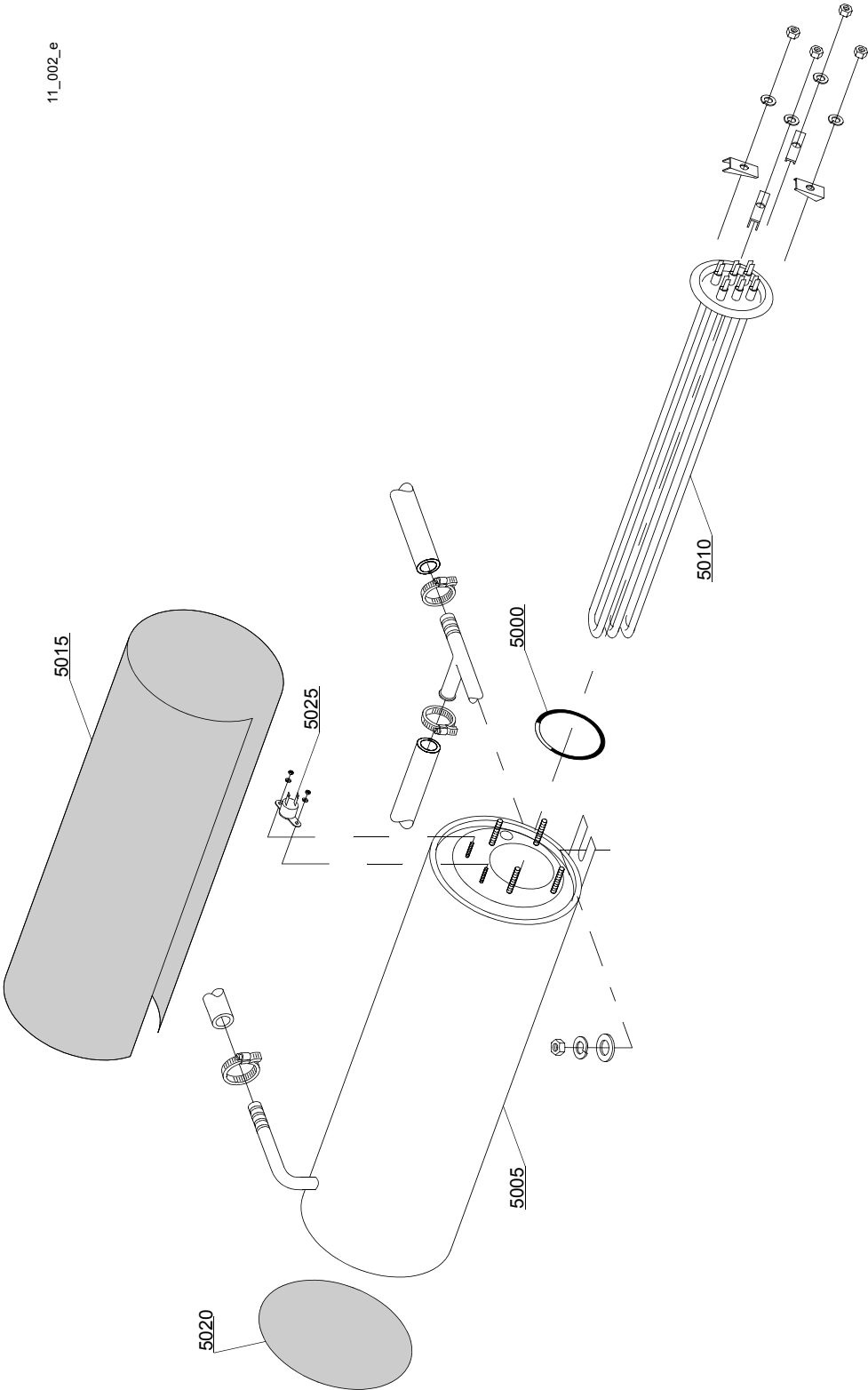

Spare parts

ID	P-code	Model	Type	Accessory	Voltage	Description
MODULE:Boiler group						
5000	13005		LUX60			OR 151 NBR O-ring
5005	150905		LUX60			Boiler
5005	150917		LUX60			AISI 314 boiler
5010	15089		LUX60			4,5/4,9KW 230/240/3 heating element
5010	15089/B		LUX60			4,5KW heating element - 254/440Vac
5010	15089/E		LUX60			6/6,53KW - 230/240/3 heating element
5010	15046		LUX60			3/3,27KW 230/240/3 heating element
5015	15066		LUX60			Insulation boiler
5020	15205		LUX60			Ø160 end piece
5025	15550		LUX60			Safety thermostat

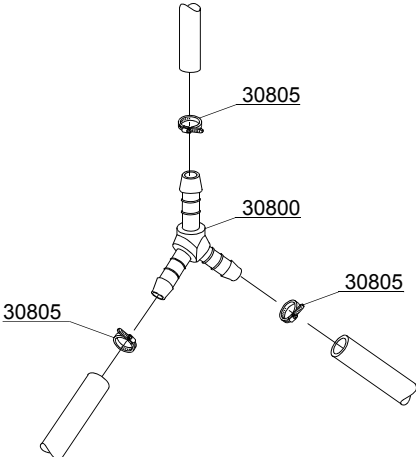

12_003ae

Spare parts

ID	P-code	Model	Type	Accessory	Voltage	Description
MODULE:3 ways connection						
30800	540091		LUX60			Ø12 mm plastic 3 ways connection
30805	11807		LUX60			12/22 clamp

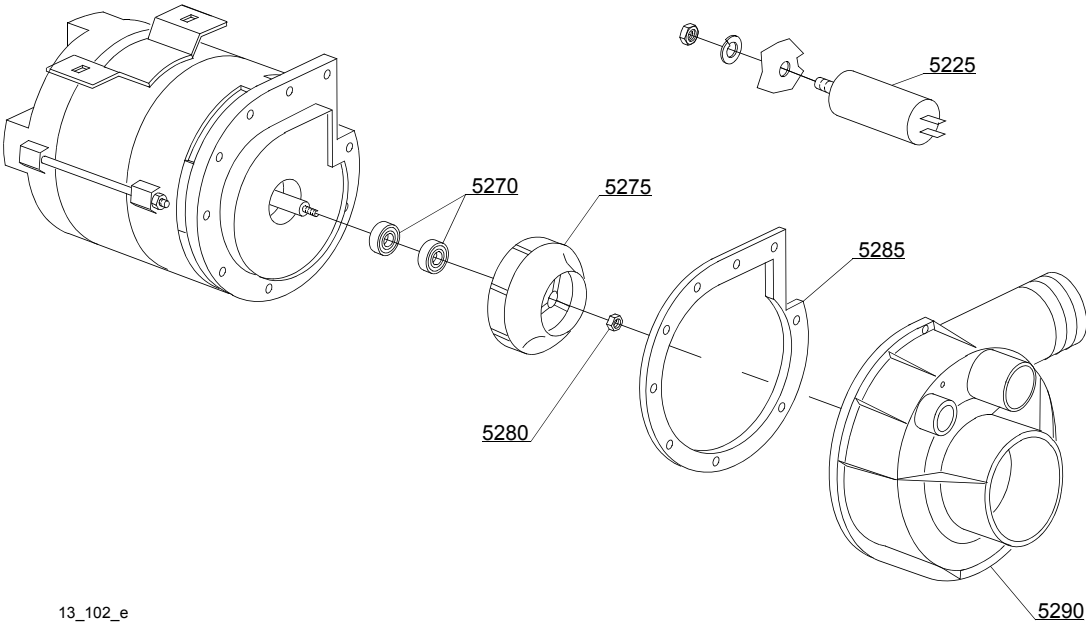
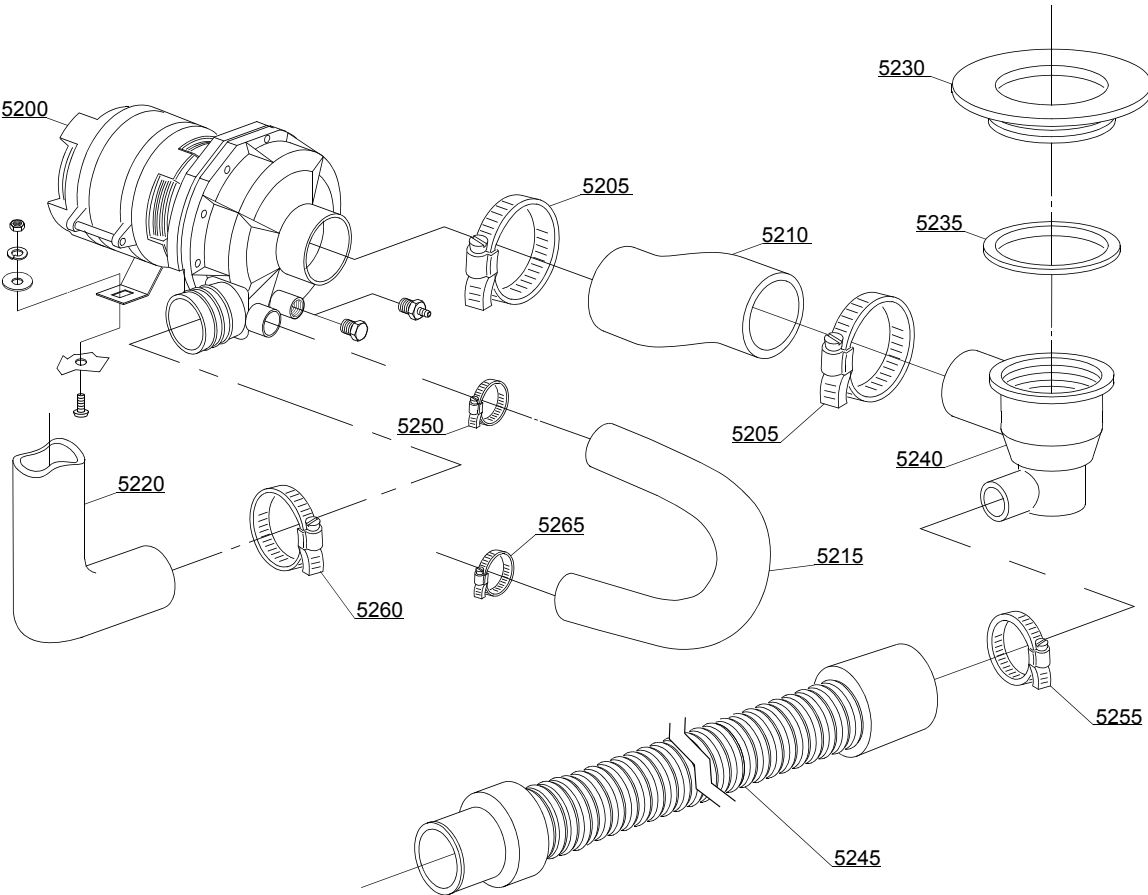

13_102_e

14_002_e

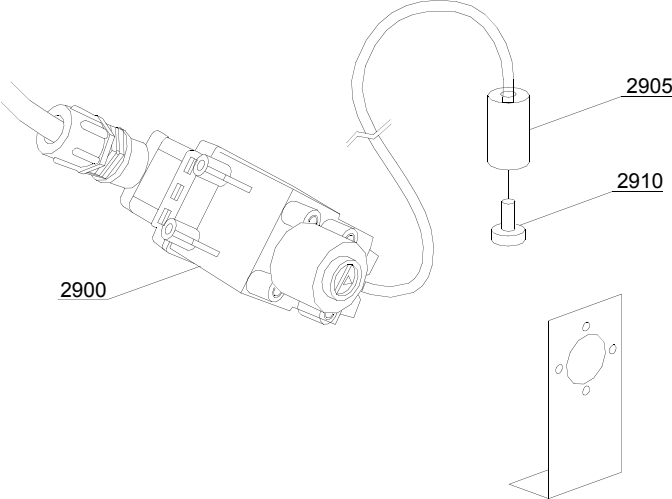
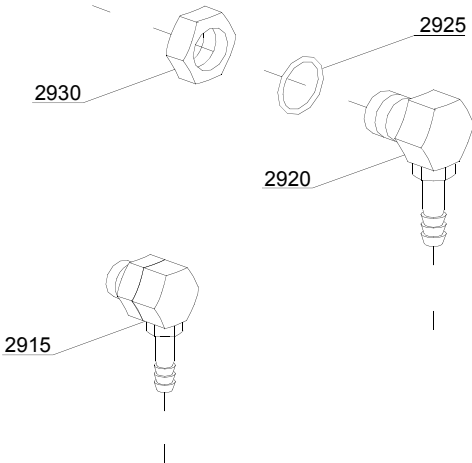

Spare parts

ID	P-code	Model	Type	Accessory	Voltage	Description
MODULE:Dosing detergent group						
2900	15108/L		LUX60	dd		Lang detergent pump
2905	12525		LUX60	dd		Counter-weight
2910	15058		LUX60	dd		Small filter
2915	15123		LUX60	dd		Compleat plastic injector
2920	15148		LUX60	dd		Steel injector
2925	15159		LUX60	dd		OR O-ring
2930	10200205		LUX60	dd		M12x1 stainless steel nut

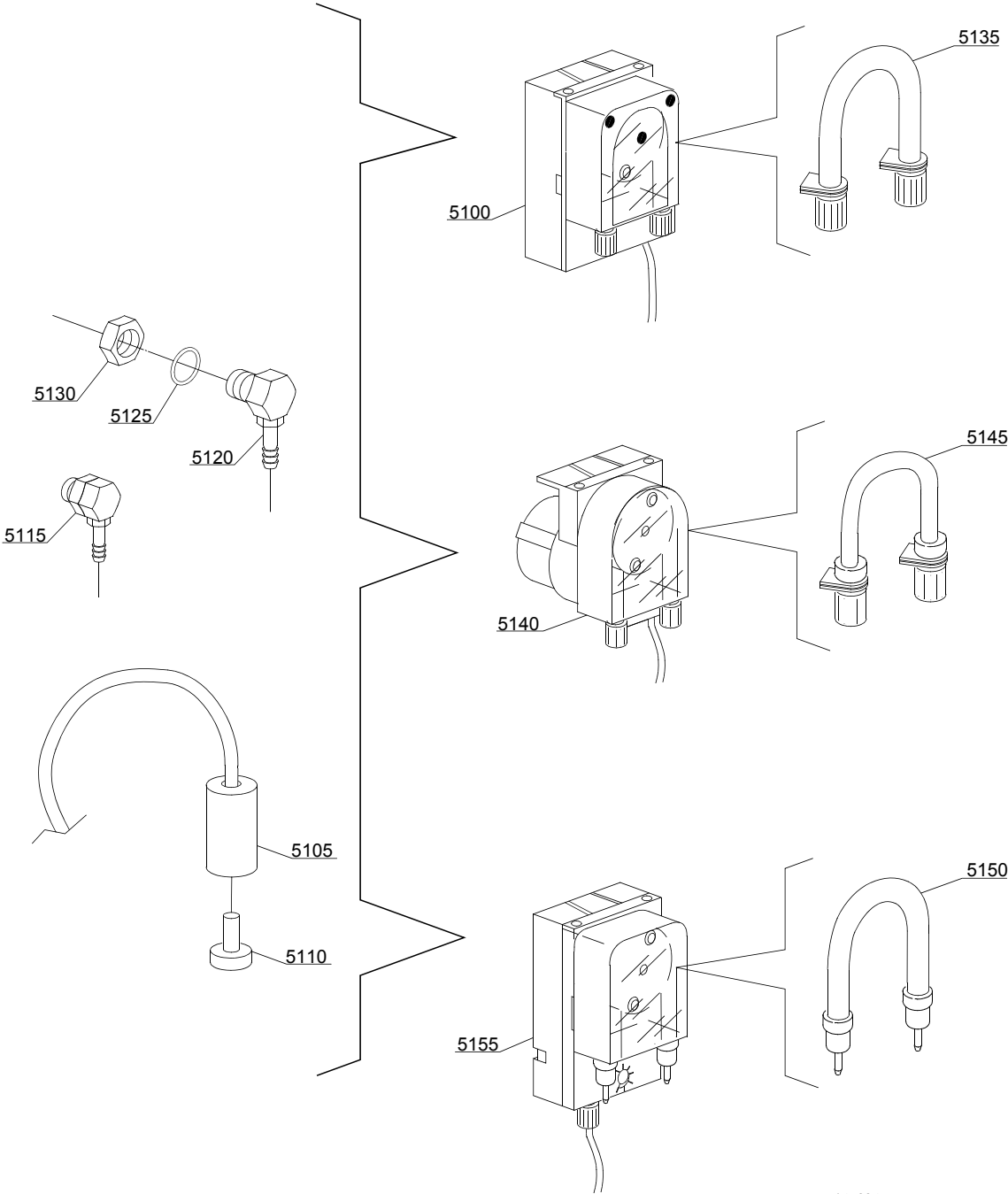

14_004_e

Spare parts

ID	P-code	Model	Type	Accessory	Voltage	Description
MODULE:Dosing detergent group						
5100	15985		LUX60	dd		Seko detergent pump
5105	12525		LUX60	dd		Counter-weight
5110	15058		LUX60	dd		Small filter
5115	15123		LUX60	dd		Compleat plastic injector
5120	15148		LUX60	dd		Steel injector
5125	15159		LUX60	dd		OR O-ring
5130	10200205		LUX60	dd		M12x1 stainless steel nut
5135	15185		LUX60	dd		Seko thermoplastic pipe
5140	15985		LUX60	dd		Germac detergent pump
5145	15108/E		LUX60	dd		Germac thermoplastic pipe
5150	15985/A		LUX60	dd		PLAS CONT thermoplastic pipe
5155	15985		LUX60	dd		PLAS CONT detergent pump

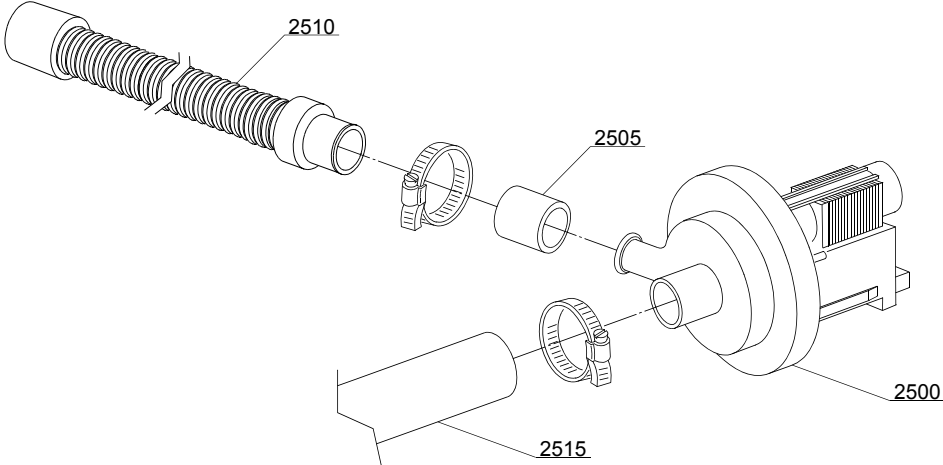

15_004ce

Spare parts

ID	P-code	Model	Type	Accessory	Voltage	Description
MODULE:Drain pump group						
2500	15101		LUX60	dp		Drain pump 220/240V 50Hz
2505	15101/D		LUX60	dp		Pipe fitting
2510	10727		LUX60	dp		Drain pipe
2515	18044		LUX60	dp		Ø28 top wash pipe

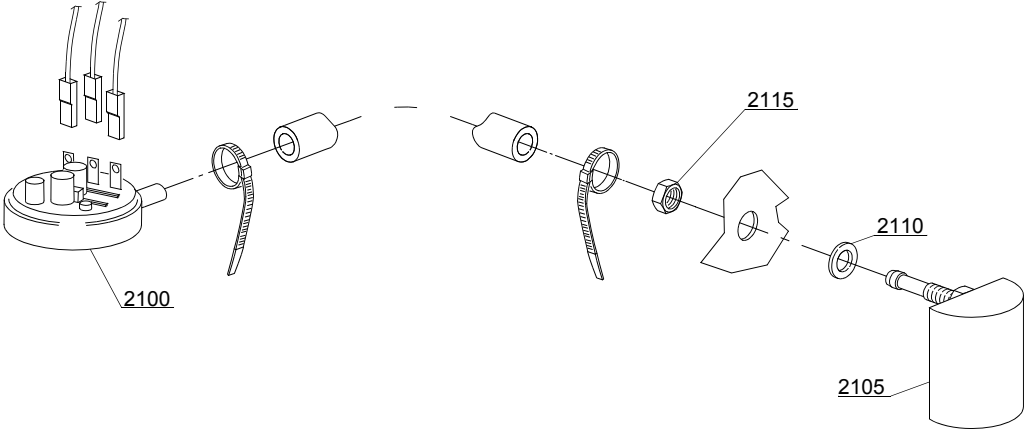

16_001_e

Spare parts

ID	P-code	Model	Type	Accessory	Voltage	Description
MODULE:Pressure switch group with air trap						
2100	10706/A		LUX60			47-27 pressure switch
2105	135911/B		LUX60			Air trap assembly
2110	13301		LUX60			O-ring
2115	11702		LUX60			M8 stainless steel nut

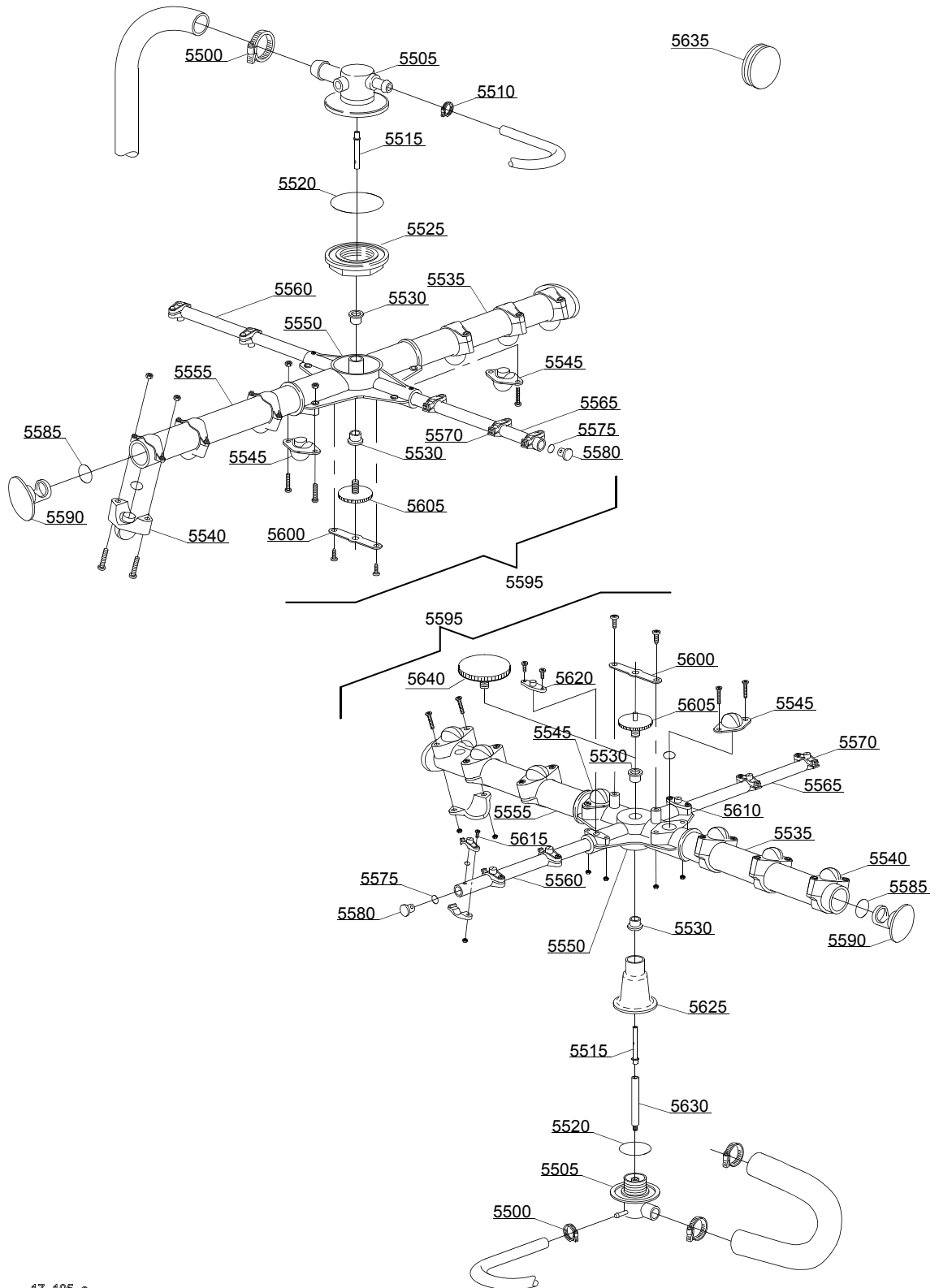

17_105_e

Spare parts

ID	P-code	Model	Type	Accessory	Voltage	Description
MODULE:Turret group with rotating arms						
5500	11806		LUX60			25/40 clamp
5505	500612		LUX60			Top/lower turret
5510	11807		LUX60			12/22 clamp
5515	15300		LUX60			Ø10x51 lower/top rinse axle
5520	13015		LUX60			6225 OR 160 NBR O-ring
5525	500623		LUX60			Ring nut for fixing turret
5530	13319		LUX60			Sliding washer
5535	15571		LUX60			Ø28 right wash pipe
5540	10261		LUX60			Ø28 raised nozzle
5545	10268		LUX60			Ø28 opened plane nozzle
5550	10259		LUX60			4 ways big rotor
5555	15572		LUX60			Ø28 left wash pipe
5560	15575		LUX60			Right rinse pipe
5565	15576		LUX60			Left rinse pipe
5570	10262		LUX60			Ø10 complet rinse nozzle
5575	13016		LUX60			2018 OR 103 NBR O-ring
5580	12532		LUX60			Ø10 plastic plug
5585	13018		LUX60			OR 2087 NBR O-ring
5590	10257		LUX60			Ø28 plastic plug
5595	15958		LUX60			Ø28 wash/rinse group
5600	10260		LUX60			Blocking ring nut rotor plaque
5605	11101/I		LUX60			Stainless steel group fixing screw
5610	10267		LUX60			Ø10 closed plane nozzle
5615	11004		LUX60			4x10 TCB Ø8 spax toothed screw
5620	10263		LUX60			Ø10 opened plane nozzle
5625	550225		LUX60			Lower pipe coupling
5630	550226		LUX60			Lower rinse axle
5635	13316/A		LUX60			DVGW hole O-ring