

tav. C
Detail C
Detail C
Détail C

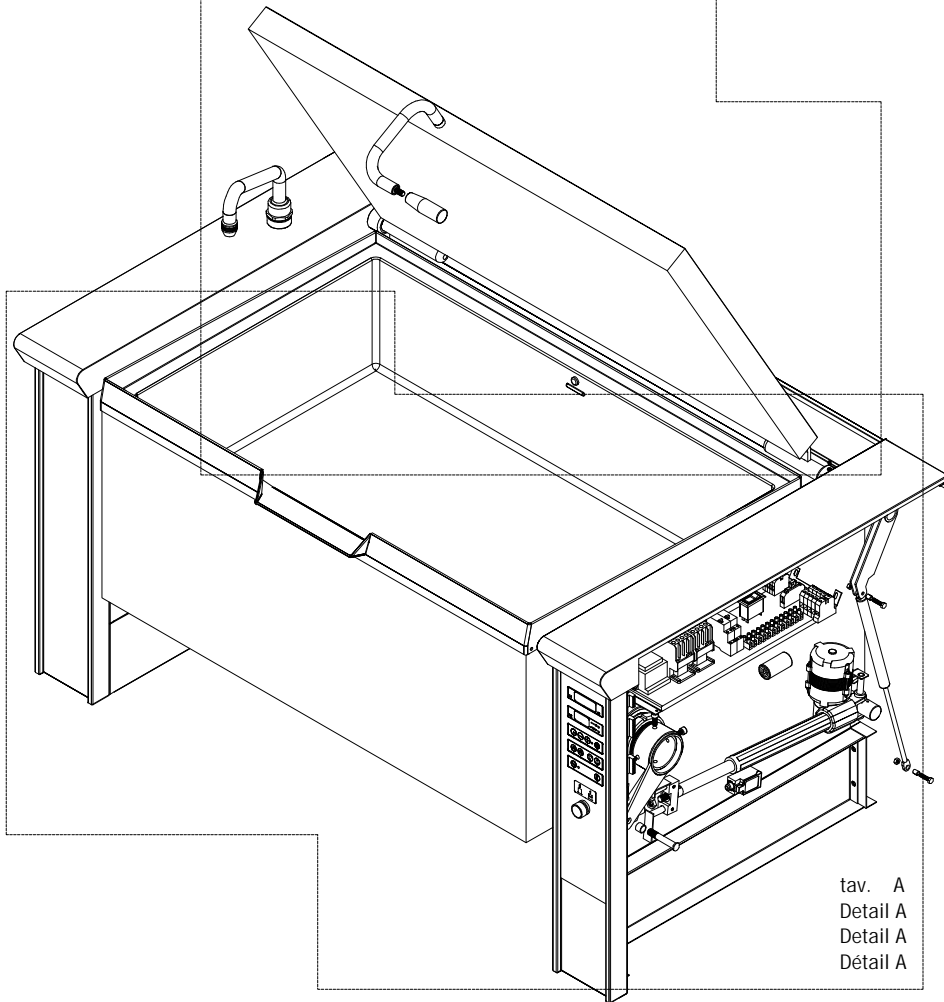

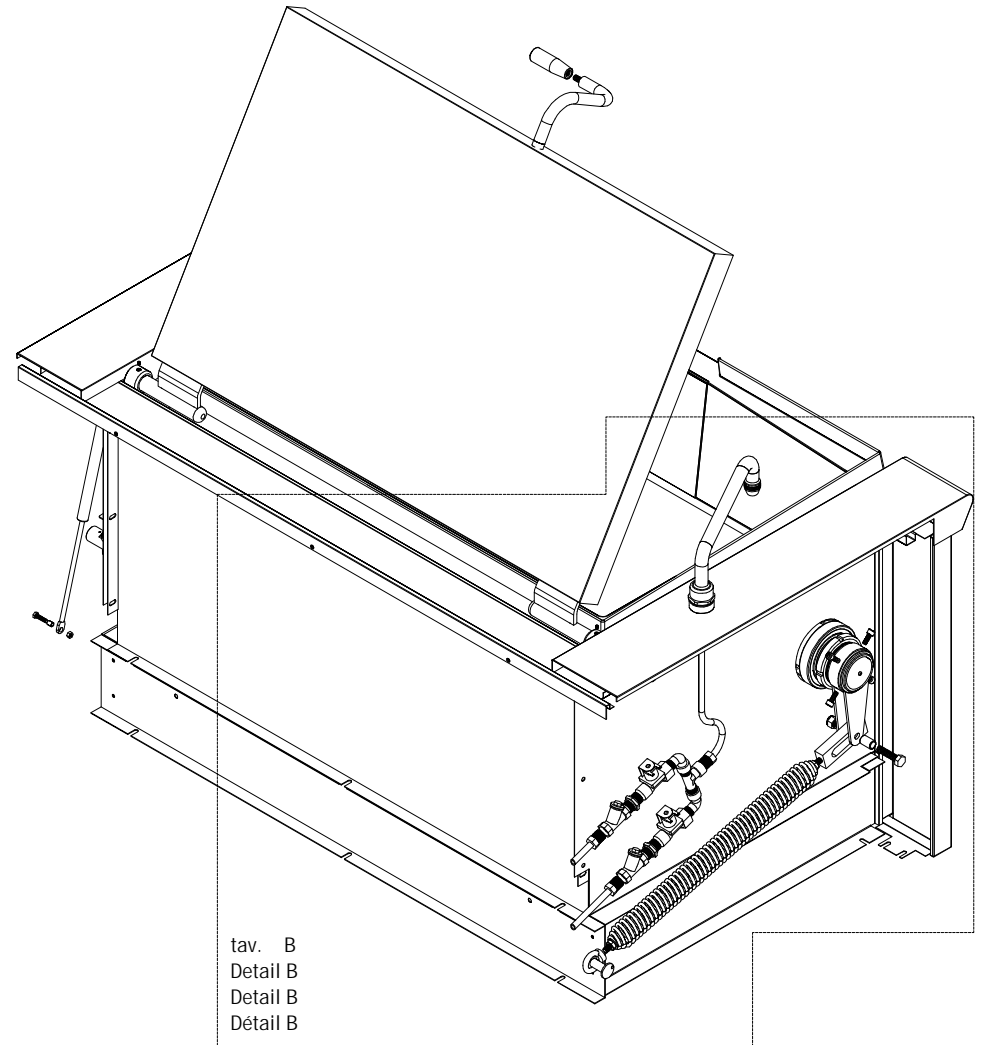

tav. A
Detail A
Detail A
Détail A

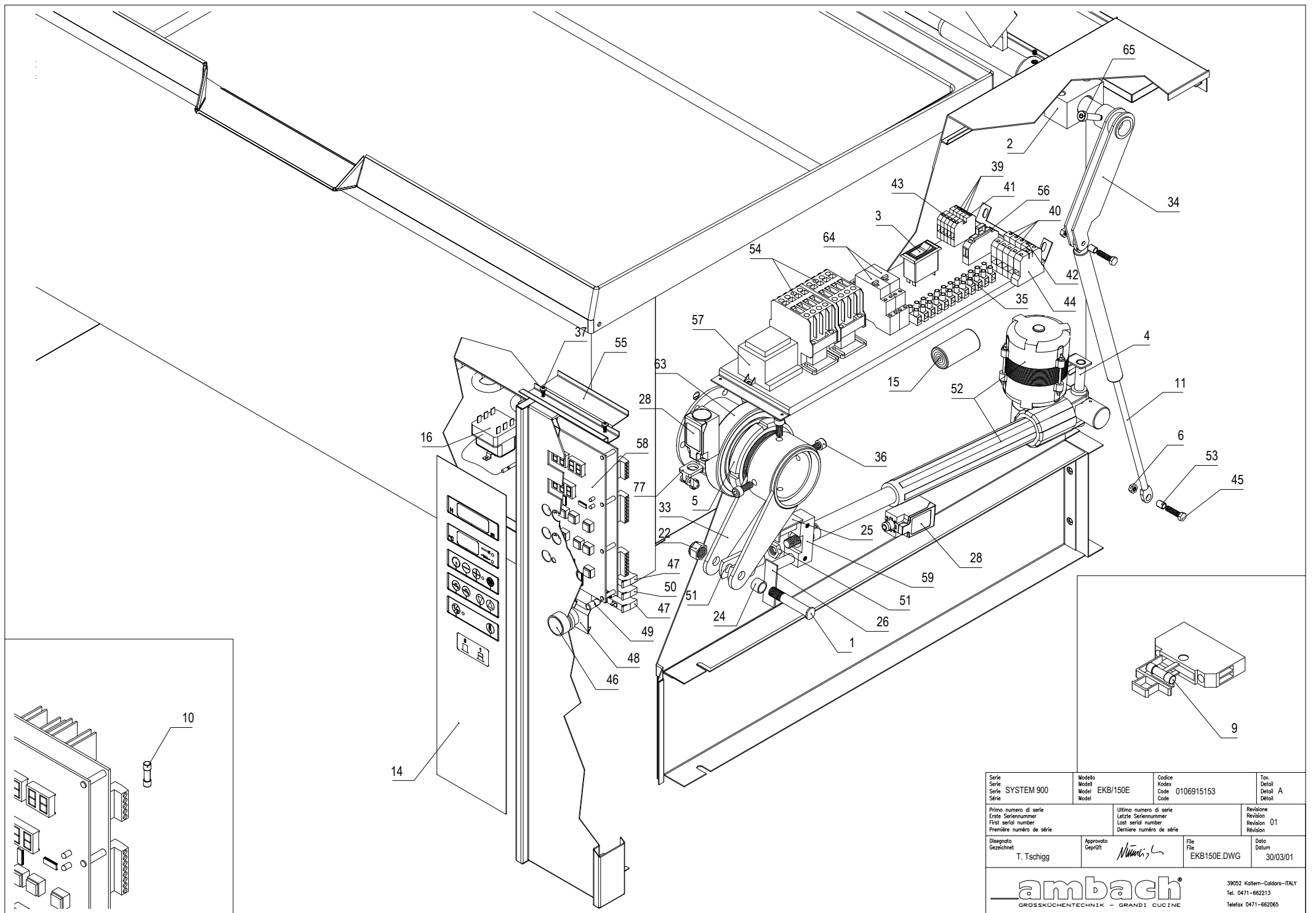

tav. B
Detail B
Detail B
Détail B

Serie Serie Série	Modello Modell Modél	Codice Kodex Code	Tav. Detail Détail
SYSTEM 900	EKB/150E	0106915153	
Primo numero di serie Erste Seriennummer First serial number Première numéro de série	Ultimo numero di serie Letzte Seriennummer Last serial number Dernière numéro de série	Revisione Revision Révision	00
Disegnato Gezeichnet	Approvato Geprüft	File Datei	Data Datum
T. Tschigg		EKB150E.DWG	04/07/00
			39052 Kallern-Caldaro-ITALY Tel. 0471-662213 Telefax 0471-662065



		39052 Kaltner-Caldaro-ITALY Tel. 0471-662213 Telefax 0471-662065	
---	--	--	--

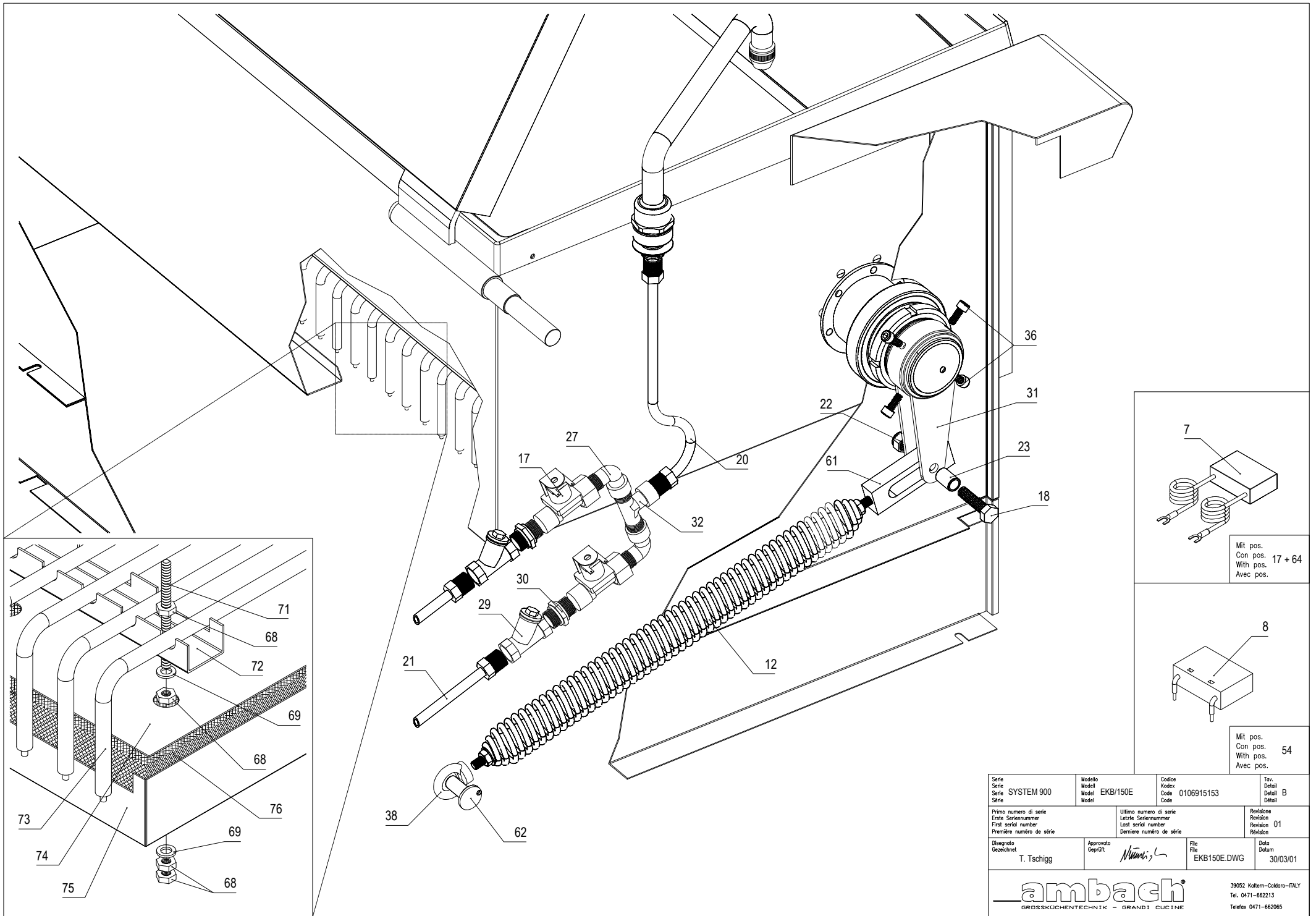

Mit pos.
Con pos.
With pos.
Avec pos.

Mit pos.
Con pos.
With pos.
Avec pos.

Serie Serie Série Série	SYSTEM 900	Modello Modell Model Model	EKB/150E	Codice Kodex Code Code	0106915153	Tav. Detail Détail	B
Primo numero di serie Erste Seriennummer First serial number Première numéro de série		Ultimo numero di serie Letzte Seriennummer Last serial number Dernière numéro de série		Revisione Revision Revision Revision	01		
Disegnato Gezeichnet	Approvato Geprüft	File Date	EKB150E.DWG	Data Datum	30/03/01		
				39052 Kallern-Caldaro-ITALY Tel. 0471-662213 Telefax 0471-662065			

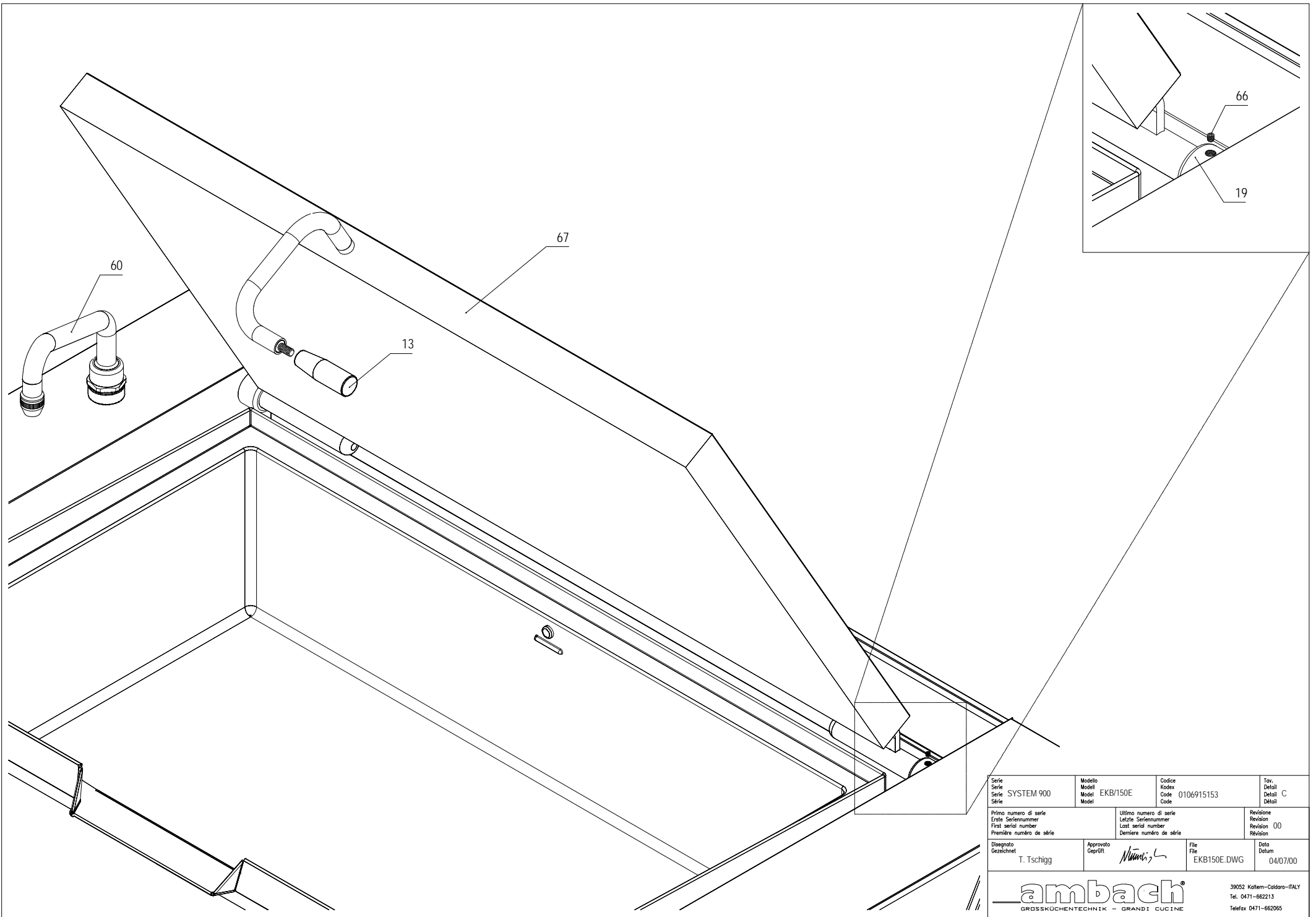

Serie Serie Série	Modello Modell Model	Codice Kodex Code	Tav. Detaill Détail
SYSTEM 900	EKB/150E	0106915153	C
Primo numero di serie Erste Seriennummer First serial number Première numéro de série	Ultimo numero di serie Letzte Seriennummer Last serial number Dernière numéro de série	Revisione Revision Révision	00
Disegnato Gezeichnet	Approvato Geprüft	File Datei	Data Datum
T. Tschigg	<i>[Signature]</i>	EKB150E.DWG	04/07/00
ambach <small>GROSSKÜCHENTECHNIK - GRANDI CUCINE</small>			<small>39052 Kallern-Caldaro-ITALY Tel. 0471-662213 Telefax 0471-662065</small>

0106915153 Model:EKB/150E

Elektro Kippbratpfanne mit elektronischer Steuerung
Electric tilting bratt pan with electronic adjustment

Brasiera elettrica con comandi elettronici
Sauteuse électrique avec réglage électronique

	Code	Beschreibung	Descrizione	Description	Désignation		St/Qty	Start	Finish	Serialnr.
1	3001115561	Schraube Spindelmotor	Vite per rubinetto monoforo	Screw for water filling cock	Vis robinet d'alimentation d'eau	KB/KK	1			
2	3008915518	Lager Deckelhub	Cuscinetto coperchio	Cover bearing	Palier de couvercle	KB/KK	2			
3	5060909759	Motorschutzschalter	Disgiuntore termico	Motor protection switch	Disjoncteur protection moteur	E-T-A 1A	1			
4	3509611373	Stift Spindelmotor	Perno attuatore	Pin spindle motor	Tige de moteur	KB/KK	1			
5	5040003847	Nutmutter	Ghiera di bloccaggio	Groove nut	Ecrou cylindrique à encoches	M 80x2	2			
6	5040310815	Mutter 6kt	Dado esagonale	Hexagon nut	Ecrou hexagonal	M6 Inox 18/8	2			
7	5050909752	Schützentstörfilter	Filtro antidisturbo	Radioshielding filter	Filtre antiparasites	400 V	4	16/02/00		807011
8	5050912346	Schützentstörfilter	Filtro antidisturbo	Radioshielding filter	Filtre antiparasites	130/240 V	2	12/04/00		915097
9	5061809773	Sicherung	Fusibile	Fuse	Fusible	8A TPME/KKME	1			
10	5061807231	Sicherung	Fusibile	Fuse	Fusible	6,3 A	2			
11	5004714039	Feder Deckelhub	Molla alzacoperchio	Spring cover lifting	Ressort pour levage couvercle	KB/System	1			
12	5004715274	Zugfeder Kipper	Molla reazione brasiera	Driving spring tilting	Ressort de traction basculem.	KB/150	1			
13	5005607080	Griff Deckel	Maniglia coperchio	Cover handle	Poignée de couvercle	M 10 KSK	1			
14	5011814552	Tastaturfolie	Mascherina scheda	Keyboard foil	Membrane protec. de clavier	KB/KK/E	1			
15	5061211324	Kondensator MFL	Condensatore MFL	Condenser MFL	Condensateur MFL	250V 6,3MF	1			
16	5061616223	Sicherheitsthermostat	Termostato limitatore	Safety thermostat	Thermostat de sécurité	KB/BP	1			
17	5018106153	Elektroventil 1/2"	Elettrovalvola 1/2"	Electric valve 1/2"	Electrovanne 1/2"	KMG/KME/50	2			
18	5041010377	Schraube 6kt	Vite te esagonale	Hexagon screw	Vis hexagonale	M12x50 INOX 18/8	1			
19	3027615510	Hülse Abdeckung Welle	Boccola alzacoperchio	Bush shaft protection	Manchon protecteur axe	KB/120/150	2			
20	5024612524	Flexibler Stahlschlauch	Tubo flessibile	Flexible steel tube	Tuyau flexible en acier	L=500	1			
21	5024612525	Flexibler Stahlschlauch	Tubo flessibile	Flexible steel tube	Tuyau flexible en acier	L=900	2			
22	5040310957	Mutter 6KT Autobl.	Dado esa. autobloccante	Hexagon screw autobl.	Ecrou hexagonal autobloquant	M12 INOX 18/8	2			
23	3027615534	Hülse Schraube Feder	Boccola vite molla	Bush screw spring	Manchon vis ressort	KB/KK	1			
24	3027615533	Hülse Schraube Spindelmotor	Boccola vite attuatore	Bush screw spindle motor	Manchon vis moteur	KB/KK	1			
25	5001014949	Anschlag Endschalter oben	Battuta finecorsa superiore	Stopper limit switch above	Butée interrupteur fin de c. haut	KB/KK	1			
26	5001014947	Anschlag Endschalter unten	Battuta finecorsa inferiore	Stopper limit switch below	Butée interrupteur fin de c. bas	KB/KK	1			
27	5050101267	Bogen Messing M+W	Angolo ottone M+F	Elbow brass M+F	Raccord coudé en laiton M+F	1/2" Art. 458	6			
28	5060909748	Endschalter ATO-11-2-i	Finecorsa ATO-11-2-i	Limit switch ATO-11-2-i	Interrupteur fin de c. ATO-11-2-i	K&M	2			
29	5050915915	Filter in Messing	Filtro in ottone	Brass filter	Filtre en laiton	1/2"	3			
30	5051001287	Doppelnippel Messing	Nipplo doppio ottone	Double nipple brass	Double raccord en laiton	1/2" Art.441	3			
31	3506315118	Halter Welle Wanne links	Supporto asse sinistro	Left shaft holder basin	Support d'axe de cuve gauche	KB/KK/SYSTEM	1			
32	5051101294	T-Stück Messing 1/2" W+M/M	T ottone 1/2" F+M/M	T brass 1/2" F+M/M	Pièce en T en laiton 1/2" F+M/M	Art. 463	1			
33	3506315119	Halter Welle Wanne rechts	Supporto asse destro	Right shaft holder basin	Support d'axe de cuve droite	KB/KK/SYSTEM	1			
34	3506315549	Hebel Deckelhub	Leva coperchio	Cover lever	Levier de couvercle	KB/150	1			
35	5060508821	Anschlußklemme	Morsettiera	Connection terminal	Borne de raccordement	PA/44 Sez-4	1			
36	5041402628	Zylinderschraube in. 6kt	Vite tcei	Hexagon cylinder screw	Vis cylindrique hexagonale	M8x20 Inox	8			
37	5041703368	Zylinderblechschaube	Vite autofilettante	Cylinder parker screw	Vis à tête cylindrique	3,9x9,5	4			
38	5006310539	Halter Feder Inox	Supporto molla inox	Spring holder inox	Support de ressort en inox	M10	1			
39	5060513981	Universalklemme grau	Morsetto universale grigio	Grey universal terminal	Borne universelle grise	6QMM	3			
40	5060513982	Universalklemme grau	Morsetto universale grigio	Grey universal terminal	Borne universelle grise	16QMM	3			
41	5060513984	Null-Leiterklemme blau	Morsetto neutro blu	Blue neutral terminal	Borne neutre bleue	6QMM	1			
42	5060513985	Null-Leiterklemme blau	Morsetto neutro blu	Blue neutral terminal	Borne neutre bleue	16QMM	1			

0106915153 Model:EKB/150E

Elektro Kippbratpfanne mit elektronischer Steuerung
Electric tilting bratt pan with electronic adjustment

Brasiera elettrica con comandi elettronici
Sauteuse électrique avec réglage électronique

Code	Beschreibung	Descrizione	Description	Désignation		St/Qty	Start	Finish	Serialnr.
43	5060513987	Erdungsklemme gelb/grün	Morsetto terra giallo/verde	Yellow/green ground terminal	Borne de terre jaune/verte	6QMM	1		
44	5060513988	Erdungsklemme gelb/grün	Morsetto terra giallo/verde	Yellow/green ground terminal	Borne de terre jaune/verte	16QMM	1		
45	5041003117	Schraube 6kt	Vite te esagonale	Hexagon screw	Vis hexagonale	M6x25 Inox	2		
46	5060919757	Druckschalter beleuchtet	Pulsante passo passo	Pressing switch lighting	Bouton poussoir lumineux	TP/KSK	1		
47	5060919758	Kontaktelement	Contatti	Contact element	Élément de contact	N.A. TP/KSK	2		
48	5060919759	Halter Kontaktelement	Basetta portacontatti	Contact element holder	Support d'élément de contact	TP/KSK	2		
49	5061103274	Glimmlampe Neon	Lampada spia neon	Neon control lamp	Lampe de contrôle au néon	BA 9S 220V	2		
50	5061119760	Lampenelement	Elemento lampada	Lamp element	Élément de lampe	TP/KSK	2		
51	5061214600	Gabel für Spindelmotor	Forcella anteriore	Force for spindle motor	Fourche moteur de bascule.	Catr33	1		
52	5061214601	Spindelmotor Catr33 200mm	Attuatore Catr33 200mm	Spindle motor Catr33 200mm	Moteur bascul. Catr33 200mm	33x200x1/220	1		
53	3027615545	Hülse Deckelhub	Boccola	Cover bush	Manchon de couvercle		2		
54	5061407226	Schütz CGE CL25	Contattore CGE CL25	Contacteur CGE CL25	Contacteur-disjonc. CGE CL25	A300T6 230V	1		
55	3000813148	Abdeckung Wasser Schaltbl.	Protezione acqua cruscotto	Water protection control panel	Protection d'eau panneau cde	KB/KK	2		
56	5061807908	Sicherungshalter	Porta fusibile	Fuse holder	Porte-fusible	Siemens	1		
57	5062808246	Transformator	Trasformatore	Transformer	Transformateur	KSKE/TPE/16	1		
58	5062909870	Platine	Scheda comando	Electronic plate	Platine électronique	TPE/190	1		
59	3006314960	Halter Anschläge Motor	Supporto cammes	Motor stroke holder	Support butée de moteur	KB/KK	1		
60	5000510477	Rohr Schwenkarm	Getto erogazione acqua	Swivel arm tube	Tuyau à bec orientable	EKB/GKB/150	1		
61	3006315590	Halter Feder vorne	Supporto molla anteriore	Spring holder in front	Support de ressort avant	KB/KK	1		
62	5009614955	Stift Feder	Perno molla	Spring pin	Goupille de ressort	KB/KK	1		
63	5008505691	Kugellager	Cuscinetto a sfera	Ball bearing	Roulement à billes	6016-2RS	2		
64	5061410308	Kontakt-Relais	Relé impulso	Contact relay	Relais contact	TL 1P 16A 220V	2		
65	5041810579	Zylinderspezialschraube	Vite tc cava es.	Hexagon cylinder screw	Vis à tête cylindrique spéciale	8x30 M6	1		
66	5040811648	Gewindestift innen 6kt	Perno filettato esagonale	Hex-socket set screw	Vis hexagonale sans tête	M5x6 Inox	2		
67	3503118187	Deckel	Coperchio	Cover	Couvercle	KB/150	1		
68	5040310815	Mutter 6kt	Dado esagonale	Hexagon nut	Ecrou hexagonal	M6 Inox	64		
69	5040202769	Beilagscheibe	Rondella	Washer	Rondelle de calage	D=6,4 Inox	32		
70		Gelöscht	Cancellato	Cancelled	Suprimé				
71	5040801551	Gewindestift	Perno filettato	Pivot	Vis sans tête	M6x80	16		
72	3006311823	Halter Heizkörper	Supporto resistenza	Heating element holder	Support de résistance	EKB/120/150	8		
73	5060814355	Heizkörper 1500W 230V	Resistenza 1500W 230V	Heating element 1500W 230V	Résistance 1500W 230V	EKB/90	12		
74	3006714961	Isolierblech Innen	Lamiera isolamento interna	Internal insulation plate	Tôle isolante intérieure	EKB/120	1		
75	3006714963	Isolierblech außen	Lamiera isolante esterna	External insulation plate	Tôle isolante extérieure	EKB/120	1		
76	5006801972	Isolierung durablanket	Isolazione interna "Cerapaper"	Internal insulation "Cerapaper"	Calorifugeage int. "Cerapaper"		1		
77	5060909440	Anfahrrolle	Rotella + finecorsa	Starting pulley	Galet d'entraînement	ø13mm AR-ATO	2		