

TAV. 7		Struttura G6SFA/EA	Structure	Structure	Struktur	G6SFA	G6SFA DIN	G6SFEA	G6SFEA DIN
	Codice	Denominazione	Denominaton	Denominaton	Bezeichnung				
1	PACU800015	Pannello comandi forno gas	Panneau de contrôle pour gaz	Oven control panel	Steuertafel Gasofen	X	X		
1	PACU800260	Pannello comandi forno elettr.	Panneau de contrôle pour électrique	El. oven control panel	Steuertafel Elektroofen			X	X
2	PACU800014	Pannello inferiore	Panneau inférieur	Lower panel	Untere Abdeckung	X	X	X	X
3	GACU800025	Facciata forno	Devanture	Face	Ofenvorderwand	X	X	X	X
4	PACU800144	Maniglia bacinella	Poignée pour bassin	Collector handle	Tropfenfänger Handgriff	X	X	X	X
5	PACU800039	Raccogliocce	Ramasse gouttes	Drop collector	Tropfenfänger Handgriff	X	X	X	X
6	GACU800022	Croschetto	Panneau de contrôle	Control panel	Stirnbrett	X	X	X	X
7	PACU800008	Fianco sinistro	Côté gauche	Left side	Linke Seite	X	X	X	X
8	PACU800012	Traversa portabacinella	Croisillon porte bassin	Cross bar support for collector	Wannequerträger	X	X	X	X
9	PACU800004	Placca	Plan de cuisson	Work plane	Platte	X	X	X	X
10	PACU800017	Supporto placca	Support plan de cuisson	Ework plane support	Plattenhalterung	X	X	X	X
11	PACU800148	Piastrina unione facciata	Egierre union panneaux	Bracket to join panels	Vorderwandverbindungsplatte	X	X	X	X
12	PACU800145	Maniglia bacinella piccola	Poignée pour bassin	Collector handle	Tropfenfänger Handgriff	X	X	X	X
13	PACU800040	Raccogliocce piccola	Ramasse gouttes	Drop collector	Tropfenfänger	X	X	X	X
14	RTCU800002	Griglia placca	Grille de plaque	Work plane grate	Plattenrost	X	X	X	X
15	GACU800014	Griglia camino	Grille pour cheminée	Chimney grill	Schornsteinrost	X	X	X	X
16	GACU800013	Dgriglia camino corta	Grille pour cheminée	Chimney grill	Schornsteinrost	X	X	X	X
17	GACU800050	Corrimano	Main courante	Handrail	Handleiste	X	X	X	X
18	PACU800066	Schienale interno	Panneau postérieur intérieur	Internal back panel	Innenriemchen	X	X	X	X
19	PACU800025	Posteriore inox	Panneau postérieur intérieur	Back panel	Inox Rückwand	X	X	X	X
20	PACU800143	Protezione rubinetti	Protection robinets	Tap protection	Hahnschutz	X	X	X	X
21	GACU800054	Basamento	Soubassement	Base	Untergestell	X	X	X	X
22	PACU800009	Fianco destro	Côté droite	Right side	Rechte Seite	X	X	X	X
23	PACU800149	Squadretta fissaggio posteriore	Egierre pour fixer le panneau postérieur	Bracket for fixing back panel	Rückwandhaltewinkel	X	X	X	X
24	GACU800122	Piedino inox	Pied inox	Inox foot	Inox Fuss	X	X	X	X
25	RTTAV00006	Supporto regolatore	Support du regulateur	Regulator support	Reglerhalterung	X	X	X	X
26	RTCU800022	Regolatore piedino	Regulateur pied	Foot regulator	Fussregler	X	X	X	X
27	PACU800142	Traversa portabacinella centrale	Croisillon porta bassin central	Cross bar support for central collector	Wannenquerträger	X	X	X	X
28	RTBF800016	Attacco magnetico	Calamit	Magnet	Magnetanschluss	X	X	X	X
29	RTCU800029	Griglia armadio	Grille placard	Cupboard grate	Schrankrost	X	X	X	X
30	GACU800029	Facciata armadio	Devanture placard	Cupboard face	Schrankvorderwand	X	X	X	X
31	PACU800067	Porta armadio	Porte placard	Cupboard door	Schranktür	X	X	X	X
32	PACU800068	Controporta armadio	Double poroi porte du placard	Cupboard counter door	Schrankgegentür	X	X	X	X
33	MPLAN40N00	Lana s/clima	Laine s/clima	S/clima wool	Isoliermaterial	X	X	X	X
34	RTCU800001	Terminale maniglia	Terminale poignée	Handle terminal	Handgriffendverschluss	X	X	X	X
35	PACU800122	Maniglia porta armadio	Poignée porte du placard	Door handle for cupboard	Schranktür Handgriff	X	X	X	X
36	RTCU700051	Bussola porta	Fourreau porte	Door bush	Türbuche	X	X	X	X

TAV. 7		Struttura G6SFA/EA	Structure	Structure	Struktur	G6SFA	G6SFA DIN	G6SFEA	G6SFEA DIN
	Codice	Denominazione	Denominaton	Denominaton	Bezeichnung				
37	GACU800037	Cerniera superiore	Charnière supérieure	Upper hinge	Rechte Türangel	X	X	X	X
38	PACU700194	Piastrina fissaggio porta cerniera	Equerre pour fixer la charnière	Bracket fix hinge	Scharnierbefestigungsplättchen	X	X	X	X
39	PABF900104	Cerniera inferiore porta	Charnière inférieure	Lower hinge	Untere Türangel	X	X	X	X
40	PACU800082	Parete armadio	Paroi placard	Cupboard wall	Schrankwand	X	X	X	X
41	PACU800269	Rinforzo corrimano	Traidissement du main courante	Handrail reinforcment	Handleistenhalterung	X	X	X	X
42	RTC800038	Griglia riduzione	Grille de reduction	Reduction grate	Reduzierrost	X	X	X	X
43	RTBF800021	Gommino Porta	Bouchon porte	Door rubber cap	Türgummi	X	X	X	X

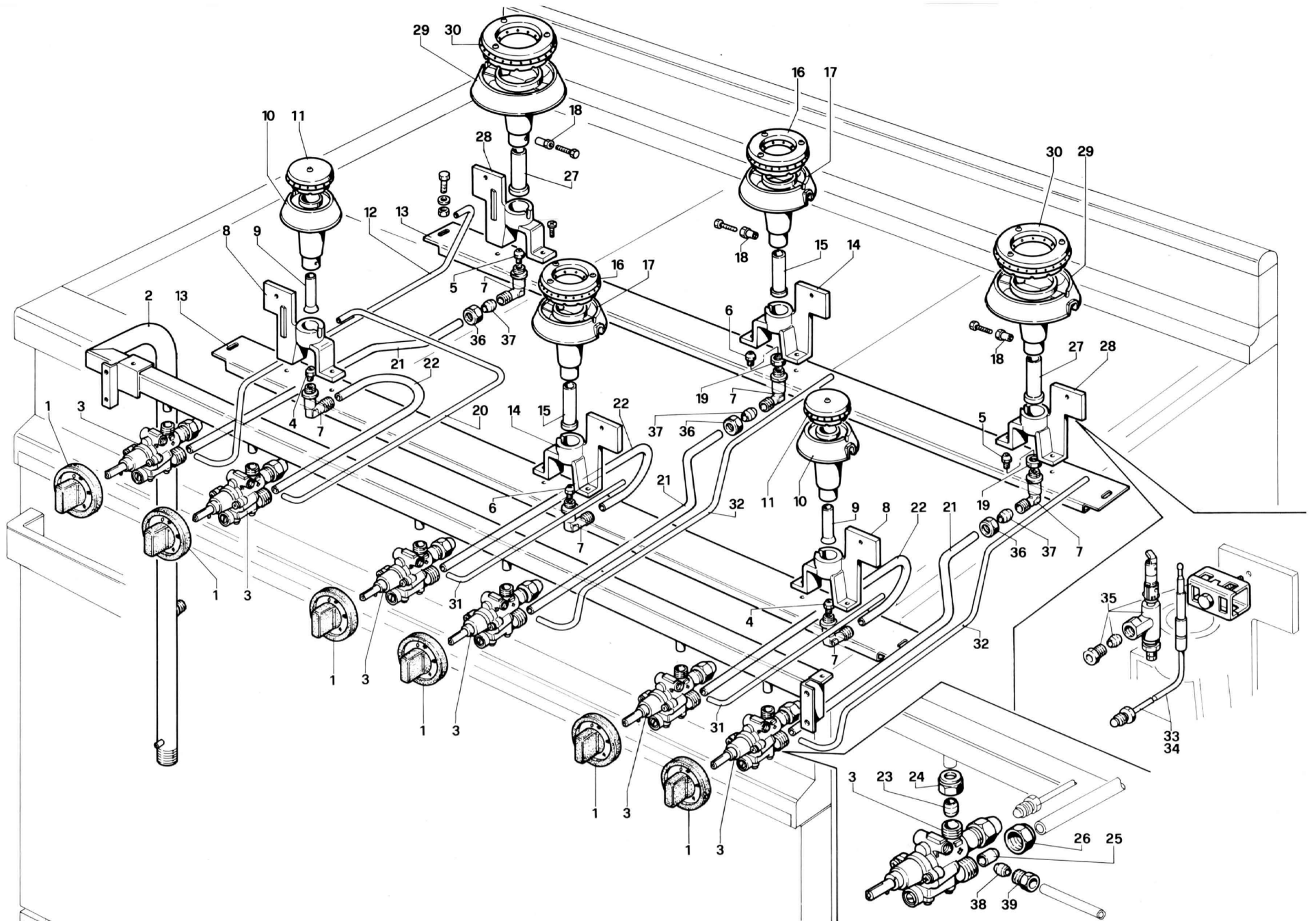

TAV.9		Impianto gas G6S/FEA/F2	Equipements pour gaz	Gas system equipment	Gasanlage	G6S	G6SFA	G6SFEA	G6SF2	DIN
	Codice	Denominazione	Denominaton	Denominaton	Bezeichnung					
1	RTCU800014	Manopola rubinetto valvolato	Bouton pour Soupape de sûrete	Safety valve knob	Hahnkugelgriff	x	x	x	x	x
2	GACU800008	Rampa G6SFA	Collecteur G6SFA	Collector G6SFA	Speiserampe G6SFA	x	x	x		x
2	GACU800005	Rampa G6S2F	Collecteur G6S2F	Collector G6S2F	Speiserampe G6S2F				x	x
3	RTCU900011	Rubinetto valvolato	Soupape de sûrete	Safety valve knob	Hahn mit Ventil	x	x	x	x	x
4	RTCU700032	Iniettore Ø 0,90 K per GPL	Injecteur Ø 0,90 K pour GPL	LPG injector Ø 0,90 K	Flüssiggaseinspritzer Ø 0,90 K	x	x	x	x	
4	RTCU700035	Iniettore Ø 1,35 K per gas metano	Injecteur Ø 1,35 K pour méthane	Methane injector Ø 1,35 K	Methangaseinspritzer Ø 1,35 K	x	x	x	x	x
4	RTCU900244	Iniettore Ø 0,78 K per GPL	Injecteur Ø 0,78 K pour GPL	LPG Injector Ø 0,78 K	Flüssiggaseinspritzer Ø 0,78 K					x
4	RTCU900183	Iniettore Ø 1,55 K per gas metano G25	Injecteur Ø 1,55 K pour méthane G25	G25 methane injector Ø 1,55 K	G25 Methangaseinspritzer Ø 1,55 K					x
5	RTCU700034	Iniettore Ø 1,30 K per GPL	Injecteur Ø 1,30 K pour GPL	LPG ininjector Ø 1,30 K	Flüssiggaseinspritzer Ø 1,30 K	x	x	x	x	
5	RTCU800243	Iniettore Ø 1,95 K per gas metano	Injecteur Ø 1,95 K pour méthane	Methane injector Ø 1,95 K	Methangaseinspritzer Ø 1,95 K	x	x	x	x	x
5	RTCU900246	Iniettore Ø 1,15 K per GPL	Injecteur Ø 1,15 K pour GPL	LPG injector Ø 1,15 K	Flüssiggaseinspritzer Ø 1,15 K					x
5	RTCU900226	Iniettore Ø 2,25 L per gas metano G25	Injecteur Ø 2,25 L pour méthane G25	G25 methane injector Ø 2,25 L	G25 Methangaseinspritzer Ø 2,25 L					x
6	RTCU900246	Iniettore Ø 1,15 K per GPL	Injecteur Ø 1,15 K pour GPL	LPG ininjector Ø 1,15 K	Flüssiggaseinspritzer Ø 1,15 K	x	x	x	x	
6	RTCU900243	Iniettore Ø 1,75 K per gas metano	Injecteur Ø 1,75 K pour méthane	Methane injector Ø 1,75 K	Methangaseinspritzer Ø 1,75 K	x	x	x	x	x
6	RTCU700220	Iniettore Ø 1,00 K per GPL	Injecteur Ø 1,00 K pour GPL	LPG injector Ø 1,00 K	Flüssiggaseinspritzer Ø 1,00 K					x
6	RTCU700252	Iniettore Ø 1,80/2,50 L per gas met. G25	Injecteur Ø 1,80/2,50 L pour méthane G25	G25 methane injectore Ø 1,80/2,50 L	G25 Methangaseinspritzer Ø 1,80/2,50 L					x
7	RTCU900006	Supporto iniettore	Support injecteur	Injector support	Einspritzertür	x	x	x	x	x
8	RTCU700006	Supporto bruciatore 3000 Kcal/h	Support brûleur 3000 Kcal/h	Burner support 3000 Kcal/h	Brennerhalterung 3000 Kcal/h	x	x	x	x	x
9	PACU700029	Regolatore aria bruciatore 3000 Kcal/h	Disp.régl.d'adm. d'air brûleur 3000 Kcal/h	Burner air shutter 3000 Kcal/h	Brennerluftregler 3000 Kcal/h	x	x	x	x	x
10	RTCU700124	Bruciatore tipo B	Brûleur B	B burner	Brenner B	x	x	x	x	x
11	GRCU800001	Spartifiamma tipo B/DIN	Chapeau de brûleur B/DIN	B/DIN burner cap	Flammentrenner B/DIN	x	x	x	x	x
12	PACU800139	Tubo pilota bruciatore posteriore sx	Tube veilleuse brûleur postérieur gauche	Left back burner pilot pipe	Hinteres Pilotbrennerrohr	x	x	x	x	x
13	PACU800073	Traversa portabrucciatori	Croisillon support brûleurs	Cross bar burner support	Brennerquerträger	x	x	x	x	x
14	RTCU700007	Supporto bruciatore 5000 Kcal/h	Support brûleur 5000 Kcal/h	Burner support 500 Kcal/h	Brennerhalterung 5000 Kcal/h	x	x	x	x	x
15	RTCU700160	Regolatore aria bruciatore 5000 Kcal/h	Disp.régl.d'adm. d'air brûleur 5000 Kcal/h	Burner air shutter 5000 Kcal/h	Brennerluftregler 5000 Kcal/h	x	x	x	x	x
16	GRCU700002	Spartifiamma 5000 Kcal/h	Chapeau de brûleur 5000 Kcal/h	Burner cap 5000 Kcal/h	Flammentrenner 5000 Kcal/h	x	x	x	x	x
17	RTCU700010	Bruciatore tipo 5000 Kcal/h	Brûleur 5000 Kcal/h	Burner 500 Kcal/h	Brenner 5000 Kcal/h	x	x	x	x	x
18	RTCU700128	Controdado fiss. regolatore aria	Contre écrou p. fixer disp. régl. adm. air	Lock nut to fix air shutter	Gegenmutter	x	x	x	x	x
19	RTCU900005	Controdado	Contre écrou	Lock nut	Gegenmutter	x	x	x	x	x
20	PACU800138	Tubo pilota bruciatore anteriore sx	Tube veilleuse brûleur antérieur gauche	Left front burner pilot pipe	Vorderes Pilotbrennerrohr	x	x	x	x	x
21	RTCU800031	Tubo alim. bruciatore posteriore	Tube de distribution brûleur postérieur	Back burner distribution pipe	Hinteres Brennerversorgungsrohr	x	x	x	x	x
22	RTCU800030	Tubo alim. bruciatore anteriore	Tube de distribution brûleur antérieur	Front burner distribution pipe	Vorderes Brennerversorgungsrohr	x	x	x	x	x
23	RTCU900014	Bicono Ø 12 fiss. rubinetto	Bicone Ø 12 pour fixer le robinet	Bicone Ø 12 to fix tap	Zweikegel Ø 12	x	x	x	x	x
24	RTCU900015	Calotta fiss. rubinetto	Écrou pour fixer le robinet	Nut to fix tap	Mutter für Hahn	x	x	x	x	x
25	RTCU900016	Bicono Ø 10 rubinetto valvolato	Bicone Ø 10 soupape de sûreté	Bicone Ø 10 safety valve	Zweikegel Ø 10	x	x	x	x	x
26	RTCU900017	Calotta Ø 10 rubinetto valvolato	Écrou Ø 10 soupape de sûreté	Nut Ø 10 safety valve	Mutter für Hahn mit Ventil	x	x	x	x	x
27	RTCU700199	Regolatore aria bruciatore 7000 Kcal/h	Disp. régl. adm. air brûleur 7000 Kcal/h	Air shutter burner 7000 Kcal/h	Brennerluftregler 7000 Kcal/h	x	x	x	x	x
28	RTCU700008	Supporto bruciatore 7000 Kcal/h	Support brûleur 7000 Kcal/h	Burner support 7000 Kcal/h	Brennerhalterung 7000 Kcal/h	x	x	x	x	x
29	RTCU700011	Bruciatore tipo 7000 Kcal/h	Brûleur 7000 Kcal/h	Burner 7000 Kcal/h	Brenner 7000 Kcal/h	x	x	x	x	x
30	GRCU700003	Spartifiamma 7000 Kcal/h	Chapeau de brûleur 7000 Kcal/h	Burner cap 7000 Kcal/h	Flammentrenner 7000 Kcal/h	x	x	x	x	x
31	PACU800137	Tubo pilota bruciatore anteriore dx	Tube veilleuse brûleur antérieur droite	Right front burner pilot pipe	Vorderes Pilotbrennerrohr	x	x	x	x	x
32	PACU800140	Tubo pilota bruciatore posteriore dx	Tube veilleuse brûleur postérieur droite	Right back burner pilot pipe	Hinteres Pilotbrennerrohr	x	x	x	x	x
33	RTCU900022	Termocoppia cm. 60	Thermocouple cm. 60	Thermocouple cm. 60	Thermoelement cm. 60	x	x	x	x	x
34	RTCU900034	Termocoppia cm. 40	Thermocouple cm. 40	Thermocouple cm. 40	Thermoelement cm. 40	x	x	x	x	x

TAV.9		Impianto gas G6S/FEA/F2	Equipements pour gaz	Gas system equipment	Gasanlage	G6S	G6SFA	G6SFEA	G6SF2	DIN
	Codice	Denominazione	Denominaton	Denominaton	Bezeichnung					
35	RTCU900025	Pilota 1 via	Veilleuse 1 voie	1 way pilot	Pilotbrenner	X	X	X	X	X
36	RTCU900013	Calotta per tubo Ø 10	Écrou pour tube Ø 10	Nut for pipe Ø 10	Mutter für Schlauch Ø 10	X	X	X	X	X
37	RTCU900012	Bicono per tubo Ø 10	Bicone pour tube Ø 10	Bicon for pipe Ø 10	Zweikegel Ø 10	X	X	X	X	X
38	RTCU900018	Bicono per tubo Ø 6	Bicone pour tube Ø 6	Bicone for pipe Ø 6	Zweikegel Ø 6	X	X	X	X	X
39	RTCU900019	Calotta per tubo Ø 6	Écrou pour tube Ø 6	Nut for pipe Ø 6	Mutter für Schlauch Ø 6	X	X	X	X	X

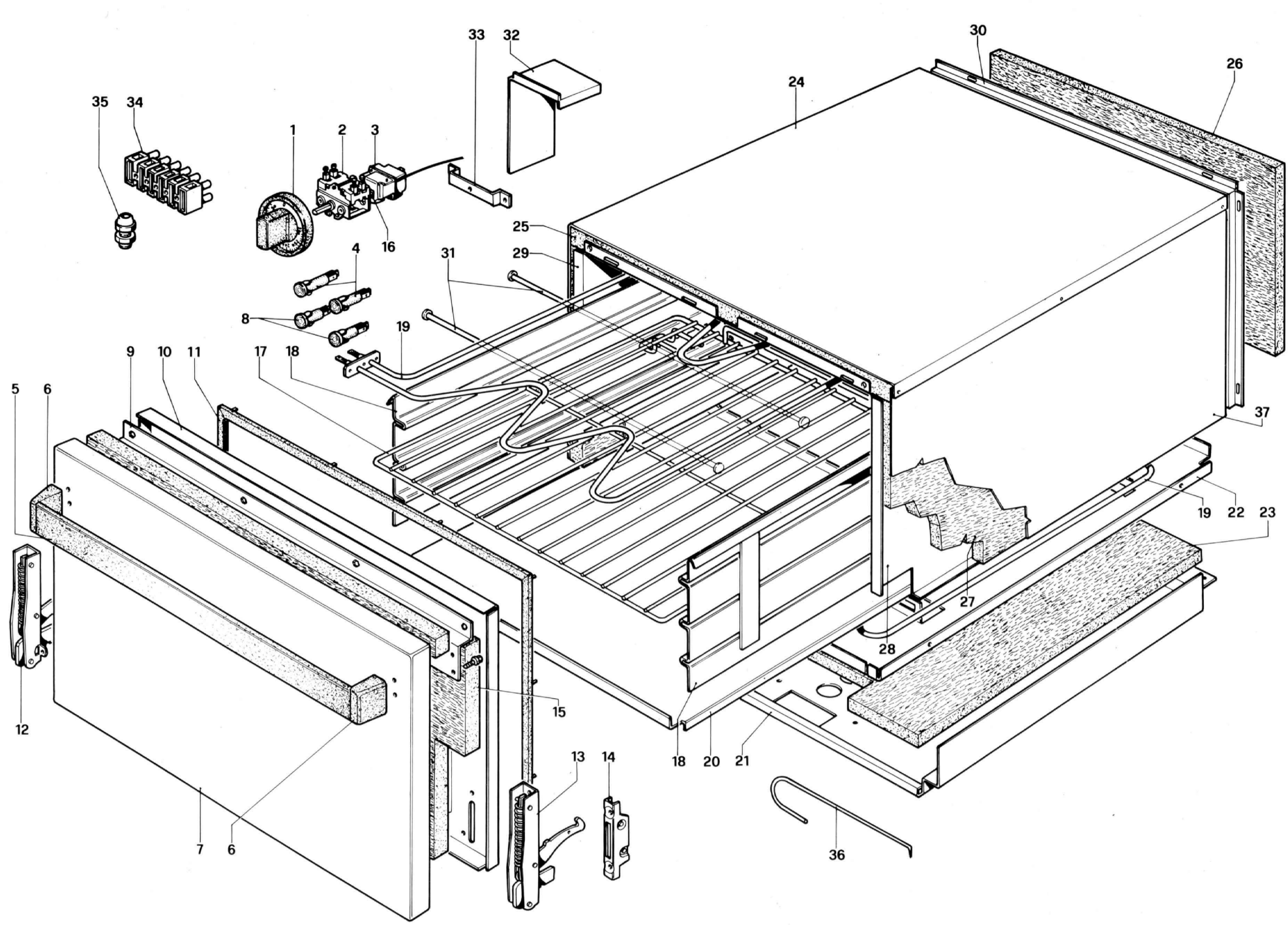

TAV. 14		Cassaforno elettrico G4-6-8	Four électrique	Electric oven	Elektro Ofen	G4SFE	G6SFEA	G8SF2E	GTFE	GT2SFERA	DIN
	Codice	Denominazione	Denominaton	Denominaton	Bezeichnung						
1	RTCU800103	Manopola termostato forno	Poignée thermostat du four	Oven thermostat handle	Thermostatkugelgriff	x	x	x	x	x	x
2	RTCU900110	Commutatore termostato forno	Commutateur thermostat du four	Oven thermostat commutator	Thermostatkommutator	x	x	x	x	x	x
3	RTCU700085	Termostato forno	Thermostat du four	Oven thermostat	Ofen Thermostat	x	x	x	x	x	x
4	RTCU900290	Lampada spia verde	Lampe témoin verte	Green warning lamp	Grüne Kontrolleuchte	x	x	x	x	x	x
5	PACU800131	Maniglia porta forno	Poignée porte du four	Oven door handle	Ofentürgriff	x	x	x	x	x	x
6	RTCU800001	Terminale maniglia	Terminal poignée	Handle terminal	Griffanschluss	x	x	x	x	x	x
7	PACU800054	Porta forno	Porte du four	Oven door	Ofentürgriff	x	x	x	x	x	x
8	RTCU900072	Lampada spia gialla	Lampe témoin jaune	Yellow warning lamp	Gelbe Kontrolleuchte	x	x	x	x	x	x
9	PACU800038	Distanziale porta forno	Entretoise porte du four	Oven door distance piece	Tür Distanzstück	x	x	x	x	x	x
10	PACU800051	Controporta forno	Contre porte du four	Oven counter door	Ofen Gegentür	x	x	x	x	x	x
11	RTCU800097	Guarnizione porta forno	Guarniture porte du four	Oven door gasket	Türdichtung	x	x	x	x	x	x
12	RTCU900027	Cerniera sinistra porta forno	Charnière gauche porte du four	Oven door left hinge	Linke Türangel	x	x	x	x	x	x
13	RTCU900026	Cerniera destra porta forno	Charnière droite porte du four	Oven door right hinge	Rechte Türangel	x	x	x	x	x	x
14	RTCU900004	Portarullino cerniera	Support charnière	Hinge support	Scharnierrollenträger	x	x	x	x	x	x
15	PACU800134	Pannello isolante porta	Panneau isolant pour porte	Door insulating panel	Isoliertafel	x	x	x	x	x	x
16	RTCU900112	Staffa alta	Étrier haute	Hingh flask	Hochbügel	x	x	x	x	x	x
17	RTCU800028	Griglia forno	Grille du four	Oven grate	Ofenrost	x	x	x	x	x	x
18	GACU800114	Laterale forno	Panneau latéral four	Oven lateral panel	Seitenwand	x	x	x	x	x	x
19	RTCU900186	Resistenza forno 2,5 kW 240 V	Resistance four 2,5 kW 240 V	Oven element 2,5 kW 240 V	Elektrischer Widerstand 2,5 kW 240 V	x	x	x	x	x	x
20	PACU800270	Piano forno elettrico	Plan du four électrique	Electric oven plan	Elektroofenebene	x	x	x	x	x	x
21	PACU800023	Fondo cassa forno	Fond caisson	Body bottom	Ofenbodenscheibe	x	x	x	x	x	x
22	PACU800264	Piano porta resistenza	Plan de support pour résistance	Support plan for element	Widerstandstragefläche	x	x	x	x	x	x
23	PACU800169	Pannello isolante fondo forno	Panneau isolant fond du four	Oven bootom insulating panel	Isoliertafel	x	x	x	x	x	x
24	PACU800336	Capilano sinistro	Panneau couvre isolant gauche	Insulating panel cover lett.	Isoliermaterialverkleidung	x	x	x	x	x	x
25	PACU800113	Pannello isolante superiore forno	Panneau isolant supérieur du four	Insulating oven upper panel	Obere Isoliertafel	x	x	x	x	x	x
26	PACU800119	Pannello isolante posteriore forno	Panneau isolant postérieur du four	Insulating oven back panel	Hintere Isoliertafel	x	x	x	x	x	x
27	PACU800172	Pannello isolante laterale forno	Panneau isolant latéral du four	Insulating oven lateral panel	Isoliertafel	x	x	x	x	x	x
28	PACU800259	Parete destra cassone forno	Paroi droite caisson four	Oven body right side	Rechte Ofenschublade	x	x	x	x	x	x
29	PACU800258	Parete sinistro cassone forno	Paroi gauche caisson four	Oven body left side	Linke Ofenschulade	x	x	x	x	x	x
30	GACU800088	Posteriore cassone forno	Postérieur caisson four	Oven body back side	Ofenschubladenrückwand	x	x	x	x	x	x
31	PACU900177	Asta portaresistenza	Tige support résistance	Rod holder for element	Widerstandshalterung	x	x	x	x	x	x
32	PACU800262	Protezione termostato forno	Protection thermostat four	Oven thermostat protection	Thermostatschutz	x	x	x	x	x	x
33	PACU800261	Squadretta fiss. pannello comando	Equerre pour fix. de panneau de contr.	Bracket to fix control panel	Steuertafelbefestigungswinkel	x	x	x	x	x	x
34	RTBF900045	Morsettiera 12 morsetti	Group de conn. des cables 12 cables	Terminal bloc 12 terminals	Klemmenbrett 12 polig	x	x	x	x	x	x
35	RTBF700021	Fermacavo Ø 16	Chaumard Ø 16	Chock Ø 16	Kabeldurchgang Ø 16	x	x	x	x	x	x
36	RTCU900030	Ferro di manovra	Crochet de déplacement	Removal hook	Bedienungseisen	x	x	x	x	x	x
37	PACU800337	Coprilana destro	Panneau couvre isolant droit	Insulating panel cover right	Isoliermaterialverkleidung	x	x	x	x	x	x