

TAV. 54		Struttura	Structure	Structure	Struktur	EC45
	Codice	Denominazione	Denominaton	Denominaton	Bezeichnung	
1	RTCU800001	Terminale manigle	Terminal de la poignée	Handle terminal	Griffanschluß	X
2	PACU800122	Maniglia porta	Poignée porte	Door handle	Handgriff	X
3	RTBF800016	Attacco magnetico	Attaque magnetique	Magnet connection	Magnetanschluß	X
4	PACU800067	Porta destra	Porte droite	Right door	Rechte Tür	X
5	MPLAN40N00	Lama s/clima	Laine pour preserver la chaleur	Insulating panel to keep the temp.	Isoliermaterial	X
6	RTCU700051	Bussola porta	Douille porte	Door bush	Türbuchse	X
7	PABF900104	Cerniera inferiore porte	Charnière inférieure	Lower hinge	Untere Türangel	X
8	PACU800157	Controporta	Contre porte	Countre door	Gegentür	X
9	RTBF800021	Gommino porta	Bouchon porte	Door rubber cap	Türgummi	X
10	PACU800037	Cerniera superiore destra	Charnière supérieure	Upper hinge	Rechte Türangel	X
11	PACU700194	Piastina fissaggio cerniera	Egierre fixe charnière	Bracket to fix hinge	Scharnierbefestigungsplättchen	X
12	PABF800226	Aquadretta portacomandi	Egierre	Bracket	Haltewinkel	X
13	PABF800133	Telaio facciata	Chassis pour panneau antérieur	Front panel frame	Vorderwandrahmen	X
14	GACU800053	Basamento	Soubassement	Base	Untergestell	X
15	PABF800252	Coperchio scatola morsettiera	Couvercle pour group de com.	Terminal block cover	Klemmbrettdeckel	X
16	GABF800096	Scatola protezione morsettiera	Egierre pour group de connection	Terminal block bracket	Klemmbrett-Haltewinkel	X
17	PABF800223	Protezione comandi	Protection pour commander	Controls protection	Schutzgehäuse	X
18	GACU800122	Piedino inox	Pied inox	Inox foot	Inox-Fuß	X
19	RTTAV00006	Supporto regolatore	Support du regulateur	Regulator support	Reglerhalterung	X
20	RTCU800022	Regolatore piedino	Regulateur pied	Foot regulator	Fußregler	X
21	PACU800009	Fianco destro	Côté droite	right side	Rechte Seite	X
22	GABF800091	Cruscotto	Panneau de contrôle	Control panel	Stirnbrett	X
23	PABF800138	Controcruscotto	Contre panneau de contrôle	Counter control panel	Gegenstirnbrett	X
24	PABF800225	Contenitore isolante vasca	Boîtier externe laine	Insulating panel outer housing	Äußeres Gehäuse	X
25	PACU800008	Fianco sinistro	Côté gauche	Left side	Linke Seite	X
26	GABF800093	Vasca EC45	Cuve EC45	Bowl EC45	Wanne EC45	X
27	GABF800098	Fondo forato	Fond perforé	Perforeted bottom	Gelochter Boden	X
28	PACU800186	Fondello caminetto superiore	Sole cheminée supérieure	Upper chimney bottom	Schornsteinbodenscheibe	X
29	GACU800013	Griglia camino	Grille de la cheminée	Chimney grate	Schornsteinrost	X
30	PACU800183	Caminetto superiore	Cheminée supérieure	Upper chimney	Oberer Schornstein	X
31	PACU800024	Posteriore inox	Panneau postérieur	Back panel	Inox-Rückwand	X
32	PABF800127	Schienale interno	Panneau postérieure intérieur	Internal back	Innenriemchen	X

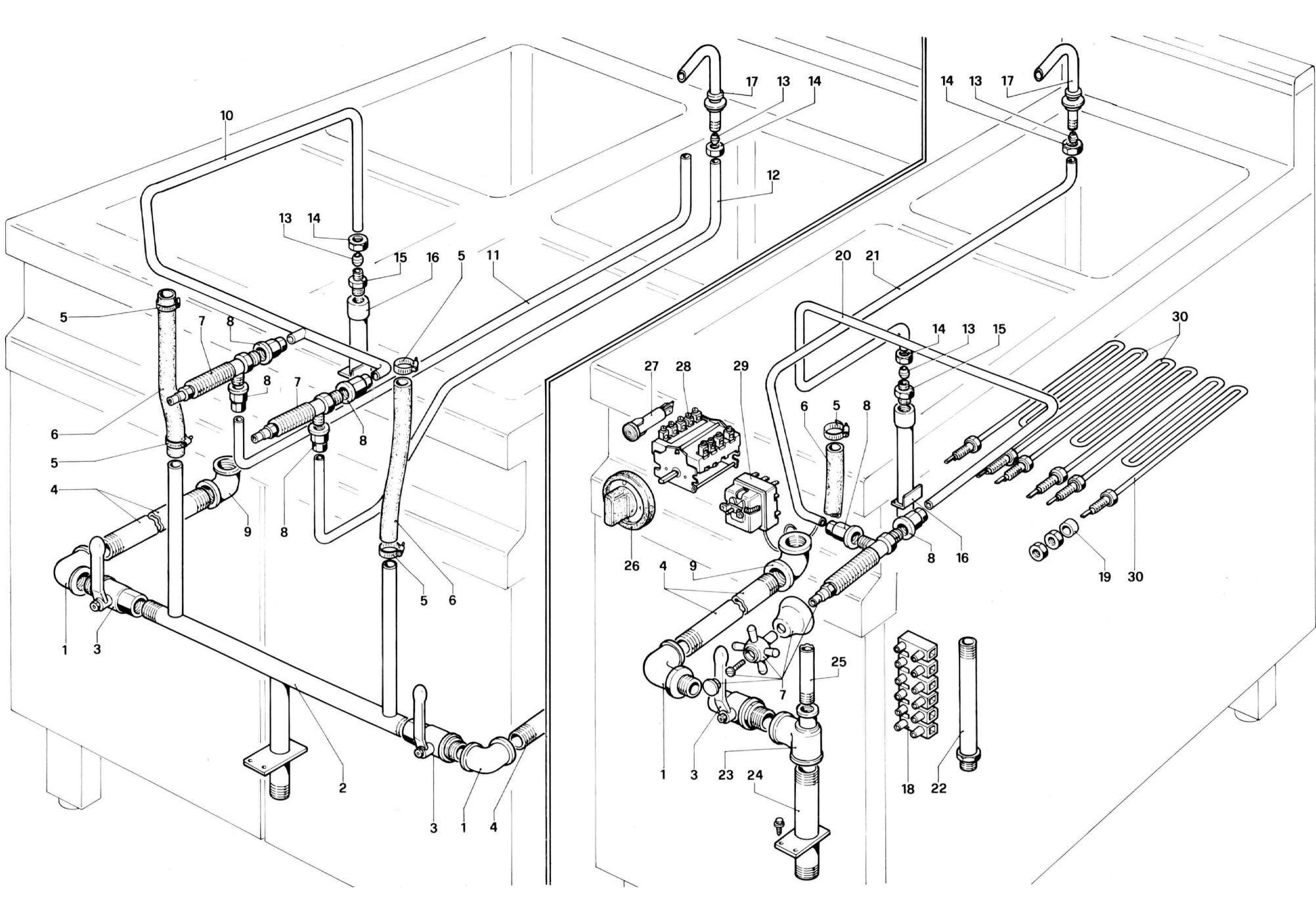

<b>TAV.56</b>		<b>Impianto elettrico</b>	<b>Equipements électrique</b>	<b>Electric system equipment</b>	<b>Elektrische Anlage</b>	<b>EC45</b>
	Codice	Denominazione	Denominaton	Denominaton	Bezeichnung	
1	RTBF800072	Gomito 1"MF	Raccord 1" MF	Elbow 1"MF	Kniestück 1"MF	×
2	RTBF800058	Rampa scarico acqua	Collecteur de decharge de l'eau	Water discharge collector	Wasserablaßrampe	×
3	RTBF800073	Rubinetto scarico acqua	Robinet de decharge de l'eau	Water discharge tap	Wasserablaßhahn	×
4	RTBF800067	Tubo scarico acqua	Tube de decharge de l'eau	Water discharge pipe	Wasserablaßrohr	×
5	RTBF800171	Fascetta Ø 24.36	Collier Ø 24-36	Clamp Ø 24-36	Schelle Ø 24-36	×
6	MPGOM21T00	Tubo PVC	Tube en PVC	PVC pipe	PVC Rohr	×
7	RTCP800018	Rubinetto acqua	Robinet de l'eau	Water tap	Wasserhahn	×
8	RTBF800126	Niples completo Ø 10	Niples Ø 10	Niples Ø 10	Nippel Ø 10	×
9	RTBF800070	Gomito 1"FF	Raccord 1"	Elbow 1"	Kniestück 1"	×
10	PABF800152	Tubo alimentazione rubinetto acqua	Tube alimentation rubinet de l'eau	Water tap feeding pipe	Wasserhahnversorgungsrohr	×
11	PABF800149	Tubo erogazione acqua vasca sinistra	Tuyau distribution eau gauche	Left water feeding pipe	Wannenversorgungsrohr	×
12	PABF800150	Tubo erogazione acqua vasca destra	Tuyau distribution eau droit	Right water feeding pipe	Wannenversorgungsrohr	×
13	RTCU900012	Bicomo per tubo Ø 10	Bicône pour tuyau Ø 10	Bicone for pipe Ø 10	Zweikegel	×
14	RTCU900013	Calotta per tubo Ø 10	Ecrou pour tube Ø 10	Nut for pipe Ø 10	Mutter für Schlauch Ø 10	×
15	RTCU900132	Niples 1/2"-3/8"	Niples 1/2"-3/8"	Niples 1/2"-3/8"	Nippel 1/2"-3/8"	×
16	GABF800035	Tubo carico acqua	Tuyau distribution eau	Water feeding pipe	Versorgungsrohr	×
17	RTBF800041	Erogatore acqua	Distributeur pour l'eau	Water distributor	Wasserversorger	×
18	RTBF800045	Morsettiera 6 poli	Groupe de connection des cables	Terminal block 6 poles	Klemmbrett 6 polig	×
19	RTBF800194	Distanziale	Entrtoise	Spacer	Distanzstück	×
20	PABF800153	Tubo alimentazione rubinetto	Tube alimentation rubinet	Tap feeding pipe	Hahnversorgungsrohr	×
21	PABF800151	Tubo alimentazione acqua	Tuyau distribution eau	Water feeding pipe	Versorgungsrohr	×
22	RTBF800178	Tubo protezione cavo	Tube de protection	Protection pipe	Schutz	×
23	RTBF800116	Raccordo 1"x1/2	Raccord 1"-1/2"	Fitting 1"-1/2	Anschlußstück 1"-1/2	×
24	RTBF800067	Tubo scarico acqua	Tube de decharge de l'eau	Water discharge pipe	Wasserablaßrohr	×
25	RTBF800115	Tubo scarico troppo pieno	Tube de decharge de l'eau	Water discharge pipe	Wasserablaßrohr	×
26	RTCP800104	Manopola commutatore	Poignée pour commutateur	Commutator knob	Kommutatorkugelgriff	×
27	RTCU900290	Lampada spia verde	Lampe témoin verte	Green warning light	Grüne Kontrolleuchtbirne	×
28	RTCP900036	Commutatore	Commutateur	Commutator	Kommutator	×
29	RTCP900074	Termostato Limit	Thermostat Limit	Limit thermostat	Limit Thermostat	×
30	RTBF800168	Resistenza elettrica 2kW 240V	Résistance électrique 2kW 240V	Over heating electr. 2kW 240V	Elektr. Widerstand 2kW 240V	×