



MOINHO CAFÉ

GRINDERS



MOINHO CAFÉ MCF 64 OD - 6.0.056.0002

GRINDER MCF 64 OD

POTÊNCIA 300 W
POWER

TENSÃO DE ALIMENTAÇÃO 230V-50Hz
POWER SUPPLY

PRODUTIVIDADE9 kg/h
GROUPS

CAPACIDADE DA TREMONHA 1,5 kg
HOPPER CAPACITY

ROTAÇÕES POR MINUTO 1400 rpm
ROTATIONS PER MINUTE

DIÂMETRO DAS MÓS 64 mm
BLADE DIAMETER

PESO LIQUIDO12,5 kg
NET WEIGHT

PESO BRUTO 14,5 kg
GROSS WEIGHT

DIMENSÕES (LxPxH) 195 x 360 x 515 mm
DIMENSIONS

DIMENSÕES DA EMBALAGEM (LxPxH) 285 x 510 x 600 mm
PACKAGE DIMENSIONS

MOINHO CAFÉ MCF 64 OD

GRINDER MCF 64 OD

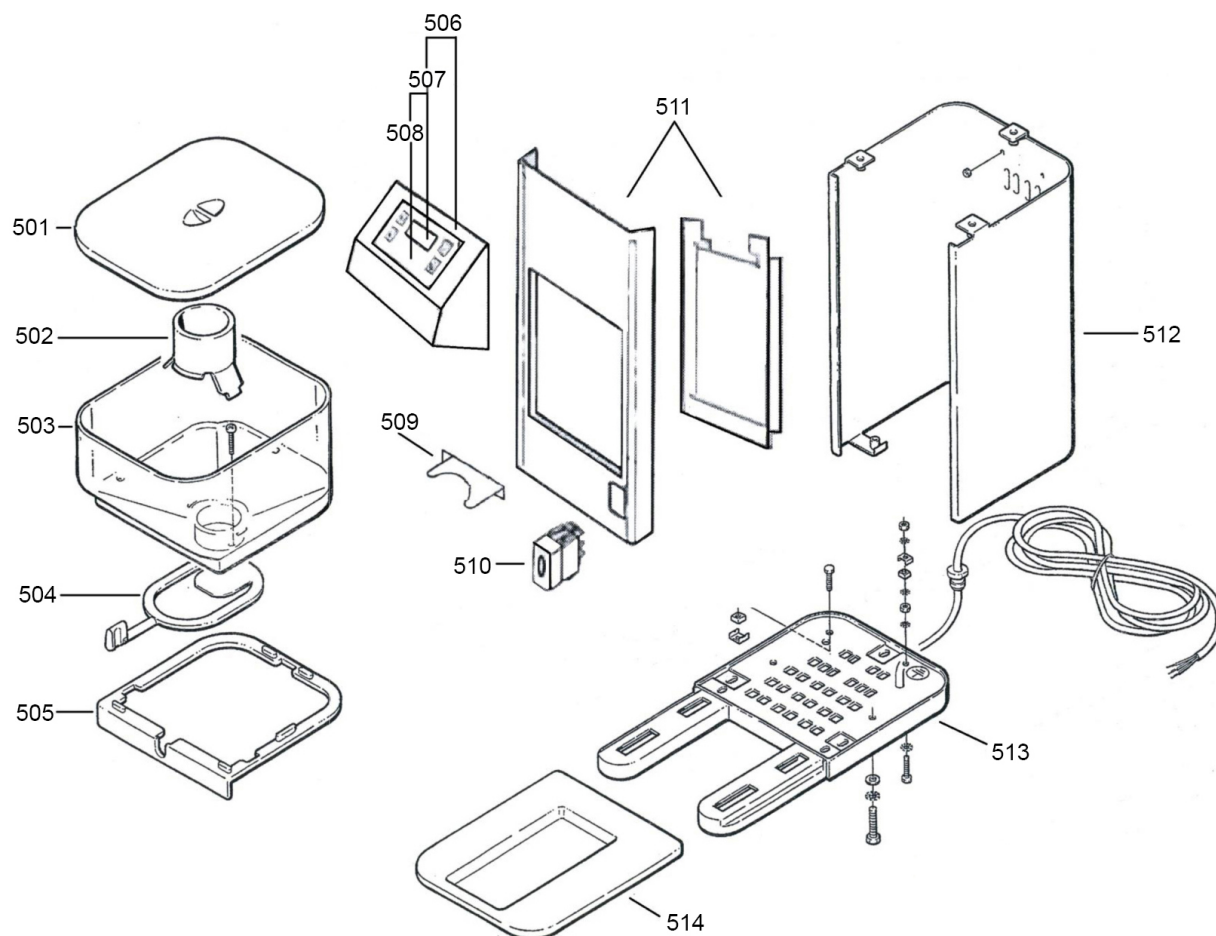

LISTA DE COMPONENTES E ACESSÓRIOS

Spare parts list

ITEM Nº	CÓDIGO	DESIGNAÇÃO	DESIGNATION
501	5.0.056.0002	TAMPA TREMONHA MCF64/128	HOPPER LID
502	5.0.056.0004	PROTECÇÃO DEEDOS MCF64/128	FINGER PROTECTION
503	5.0.056.0001	TREMONHA MCF64/128	1,4KG HOPPER WITH COUPLING
504	5.0.056.0003	FECHE TREMONHA MCF64/128	HOPPER SHUTTER
505	5.0.056.0005	SUPORTE TREMONHA MCF64/128	HOPPER COLLAR
506	5.0.056.0042	PAINEL COMANDO COMPLETO MCF64/128 OD	COMPLETE CONSOLE (FACEPLATE, PUSH BUTTON DISPLAY, LABEL)
507	5.0.056.0041	BOTAO + ETIQUETA DISPLAY MCF64/128 OD	PUSH BUTTON DISPLAY + BUTTON LABEL
508	5.0.056.0043	ETIQUETA DISPLAY MCF64/128 OD	PUSH BUTTON LABEL
509	5.0.056.0044	FORQUILHA MCF64/128 OD	ODM PLASTIC FILTER HOLDER BRACKET
510	4.0.050.0030	INTERRUPTOR N/ LUMINOSO 8216052086	POWER SWITCH
511	5.0.056.0040	PAINEL FRONTAL MCF64 OD/128 OD - POLIDO	COMPLETE 320mm ODM FRONTAL
512	5.0.056.0024	CARROÇARIA MCF64/128 - POLIDA	320mm POLISHED BODY
513	5.0.056.0022	BASE MCF64/128	BASE WITH RUBBER FEET
514	5.0.056.0021	PRATO RECUPERAÇÃO CAFE MCF64/128	COFFEE TRAY

MOINHO CAFÉ MCF 64 OD

GRINDER MCF 64 OD

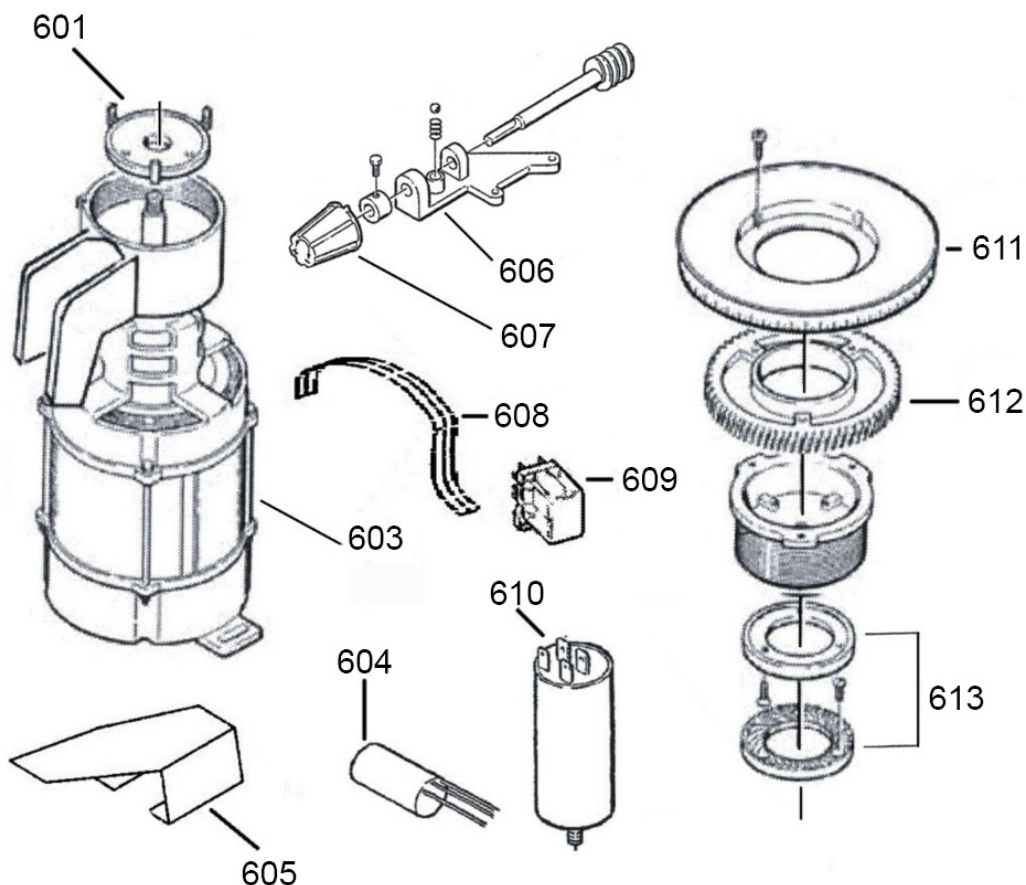

LISTA DE COMPONENTES E ACESSÓRIOS

Spare parts list

ITEM Nº	CÓDIGO	DESIGNAÇÃO	DESIGNATION
601	5.0.056.0051	PORTA MOS MCF64	PAD FOR FLAT GRIND BURR
603	5.0.056.0082	MOTOR 230V/50HZ MCF64 OD	COMPLETE ODM MOTOR-1400RPM-230/240V 50HZ FOR FLAT GRIND BURR
604	5.0.056.0065	FILTRO ANTI-RUIDO MCF64/128	INTERFERENCE SUPPRESSOR 220/230/240V
605	5.0.056.0078	SUPORTE MOTOR MCF64 OD	HIGH ODM MOTOR SUPPORT
606	5.0.056.0012	VEIO REGULAÇÃO MOAGEM MCF64/128	COMPLETE MICROMETER ADJUSTMENT WITH HANDLE
607	5.0.056.0013	MANIPULO VEIO REGULAÇÃO MCF64/128	ADJUSTMENT HANDLE
608	5.0.056.0072	CABO UNIDADE ELECTR. MCF64/128 OD	DATA CABLE
609	5.0.056.0071	UNIDADE ELECTRONICA MCF64/128 OD	ELECTRONIC BOARD 220/230/240V
610	5.0.056.0061	CONDENSADOR 10µF	10µF CAPACITOR 220/230/240V
611	5.0.056.0011	ANEL REGULAÇÃO MOAGEM MCF64/128	ADJUSTMENT DISK WITH SEPARATE NUMBERED LABEL
612	5.0.056.0014	RODA DENTADA MCF64/128	TOOTHED WHEEL
613	5.0.056.0054	MOS (PAR) Ø64 MCF64	FLAT GRINDSTONES - COUPLE

MOINHO CAFÉ MCF 64 OD

GRINDER MCF 64 OD

ESQUEMA ELECTRICO

Electric Scheme

