

SUPERLOTUS 70 TOP

GAS / GAS / GAS / GAZ

TP2T-78GP

	1	2	3
Vedi Pagina			
See Page	269	270	272
Siehe Seite			
Voir Page			
Ver Página			

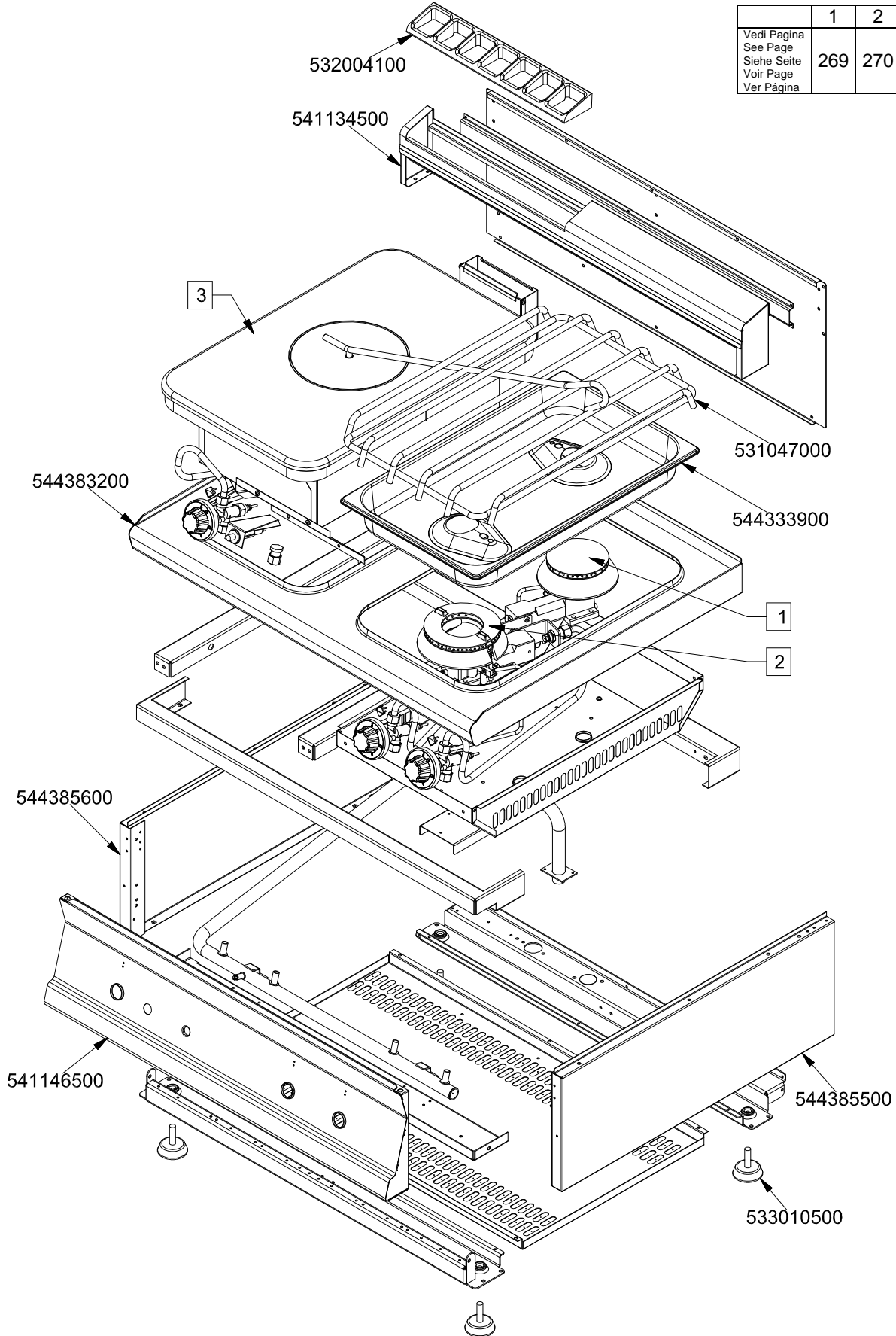

560041600M00P00

PCT-G R

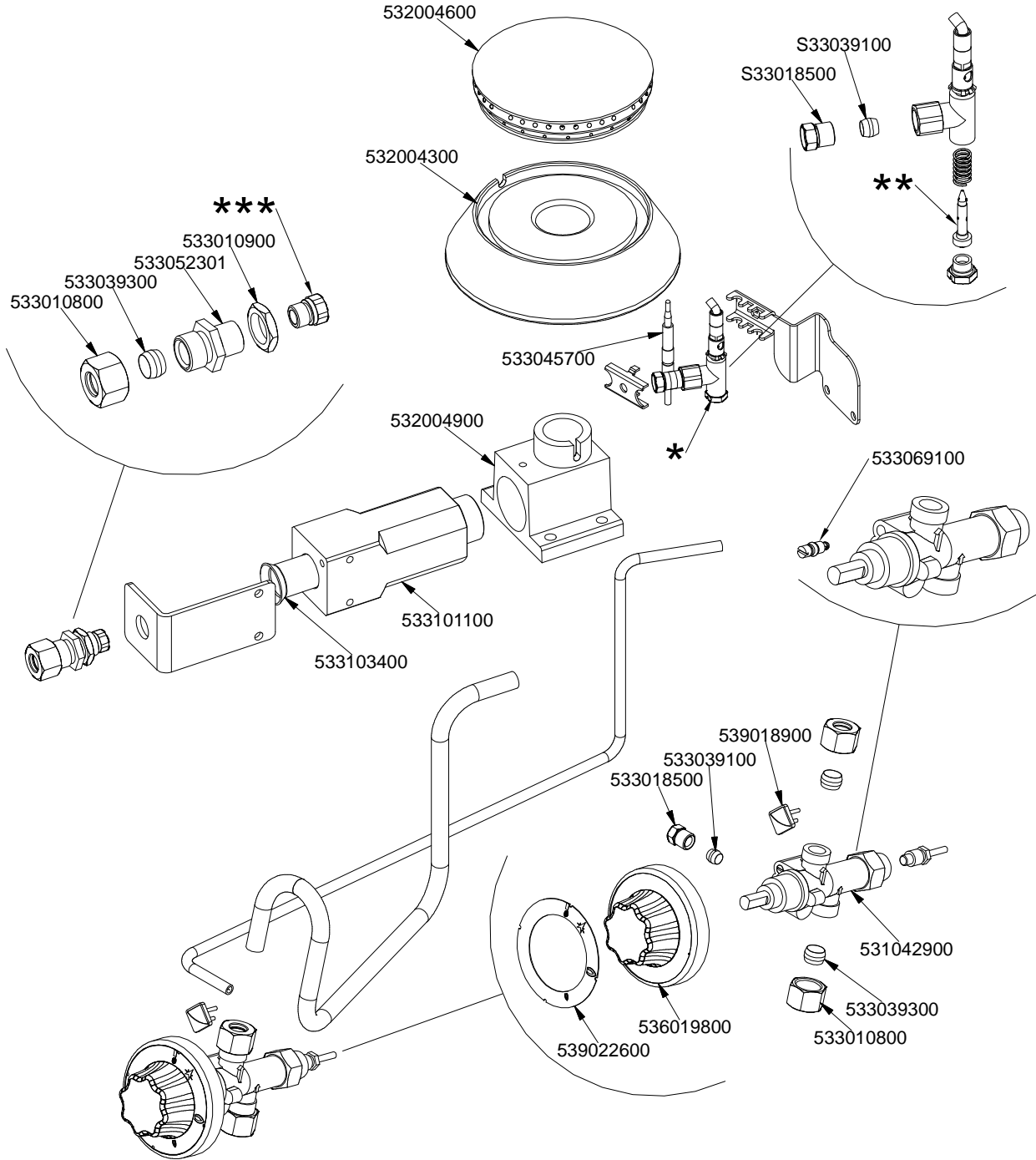

	*	**	***
G30-28+30mbar G31- 37mbar	533091400	533091000	533043900
G30- 50mbar	533091400	533091000	533019300
G20- 20mbar G25- 25mbar	533091500	533091200	533031000
G20- 20mbar DE-AT	533091500	533091200	533031000
G25- 20mbar	533091500	533091200	533043500
G25- 25mbar NL	533091500	533091200	533019400

560038600M00P00

PCT-G UR

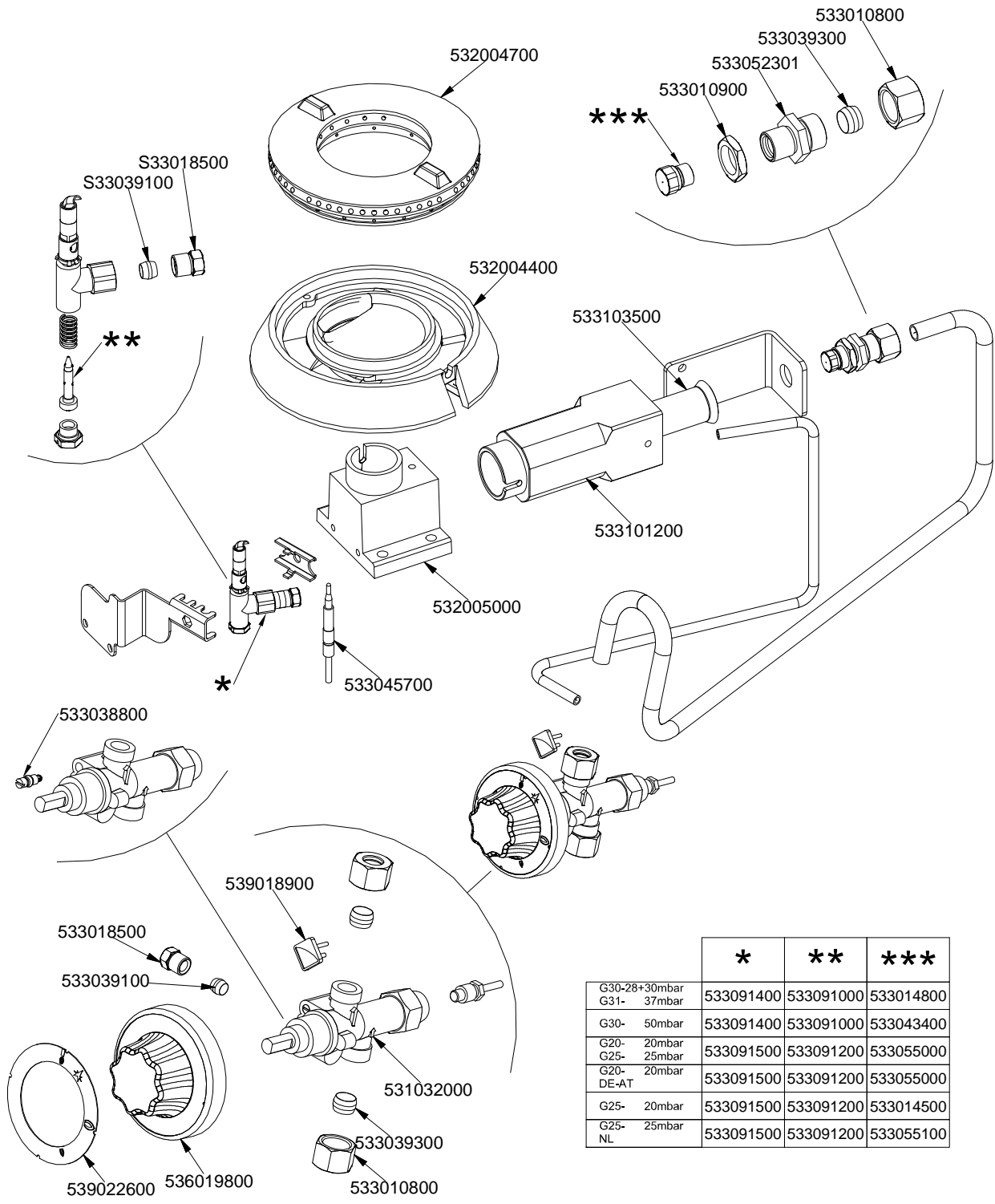

	*	**	***
G30-28+30mbar G31- 37mbar	533091400	533091000	533014800
G30- 50mbar	533091400	533091000	533043400
G20- 20mbar G25- 25mbar	533091500	533091200	533055000
G20- 20mbar DE-AT	533091500	533091200	533055000
G25- 20mbar	533091500	533091200	533014500
G25- 25mbar NL	533091500	533091200	533055100

560038700M00P00

TPT

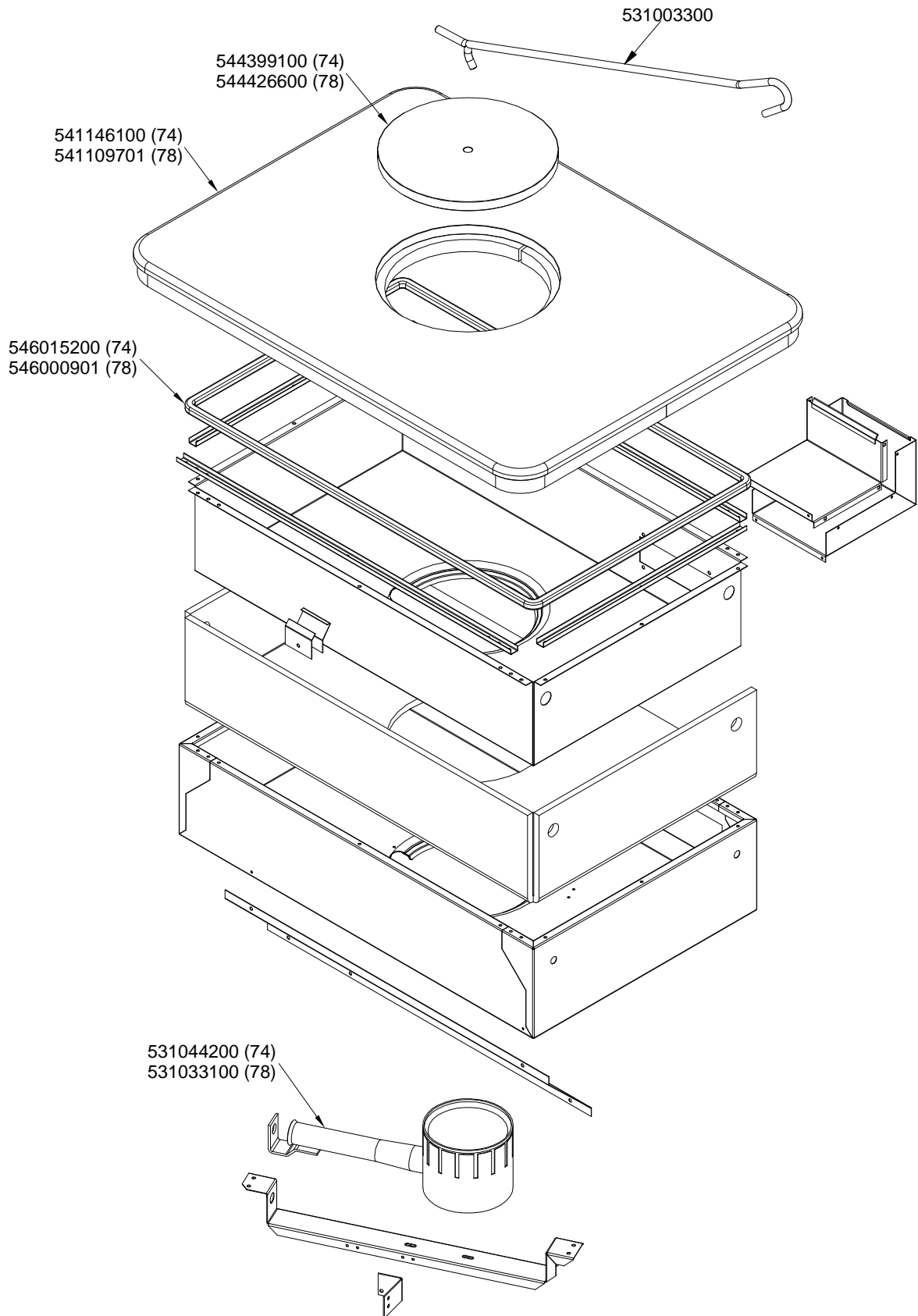

560041400M00P00

SUPERLOTUS 70≥0602

COMPONENTI COMUNI / STANDARDS PARTS / UEBLICHE TEILE / COMPOSANTS COMMUNS

TPT

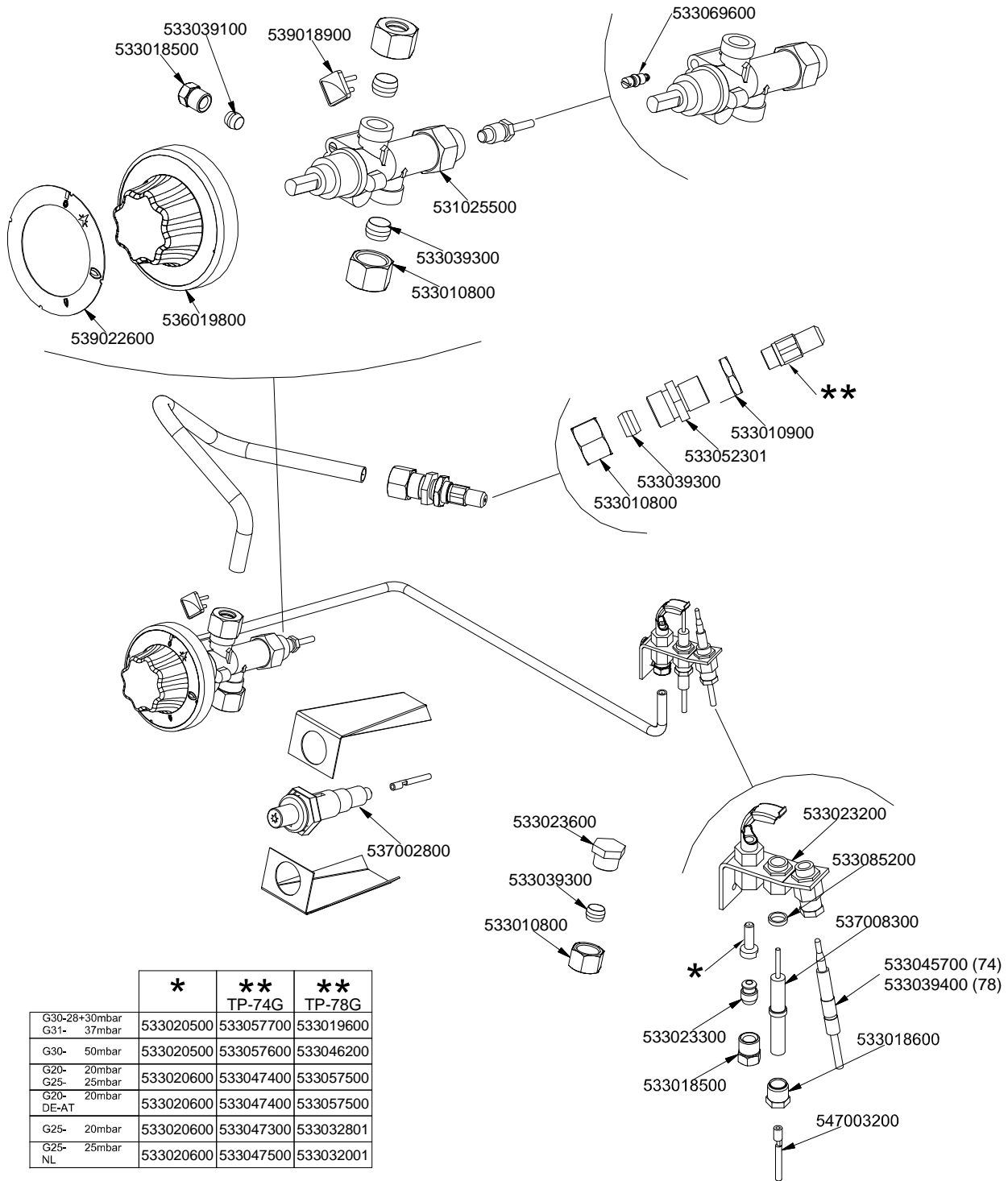

	*	**	**
		TP-74G	TP-78G
G30-28+30mbar G31- 37mbar	533020500	533057700	533019600
G30- 50mbar	533020500	533057600	533046200
G20- 20mbar G25- 25mbar	533020600	533047400	533057500
G20- DE-AT	533020600	533047400	533057500
G25- 20mbar	533020600	533047300	533032801
G25- NL	533020600	533047500	533032001

560035102M00P00

Page	Pos	Code	Description
001		532004100	FLUE GRID L=370 70LINE (RAF)
001		541134500	LOW SPACER 78 1 LHD GRID
001		531047000	2 BURNER GRID FOR PC-700
001		544333900	BURNER CONTAINER 1/1GN R 304
001		544383200	UPPER PLATE PC-78GP CF4-78GP/GPE
001		544385600	LEFT SIDE OF 70T LINE
001		541146500	CONTROL PANEL TP2-98G
001		533010500	LEG M10*25 D.40
001		544385500	RIGHT SIDE OF 70T LINE
002		533039100	
002		533018500	
002		532004600	BURNER COVER RING R D104
002		532004300	MIDDLE BURNER BODY 70LINE P.
002		533010900	NUT M14*1 H.4
002		533052301	JOINT FOR NOZZLE HOLDER
002		533039300	BICONE §10
002		533010800	TUBE NUT D.10 M16*1,5
002		533045700	THERMOCOUPLE M9*1 500
002		532004900	ELBOW FITTING OF BURNER VENTURI R
002		533069100	BY PASS COCK §60 20S
002		533101100	BURNER VENTURI R
002		533103400	AIR ADJUSTMENT BUSHING D20 EST.H57
002		539018900	INDEX FOR KNOB
002		533039100	BICONE §6
002		533018500	FITTING FOR BICONE D.6 M10*1
002		531042900	B.PASS §60 SAFETY COCK PC/CF 90
002		536019800	BLACK KNOB §70 PIN §8*6,5
002		539022600	GRADUATED STICKER FOR KNOB
002		533091400	P.NOZZLE §100 UG.§20 PC90 LPG-FLUS
002		533091000	NOZZLE 0.100 §20
002		533043900	NOZZLE §115 CH12*14 F-CW4
002		533019300	NOZZLE §100 G-FQ5 F-CW
002		533091500	PILOT NOZZLE S.100 §30 PC90 NAT.GAS
002		533091200	PILOT NOZZLE 0100 Ø35 PIL.PC
002		533031000	NOZZLE §175 CH12X14
002		533043500	NOZZLE §190 CH12*14 G25 PC4R
002		533019400	NOZZLE §180 CH12*14 L-FQ5
003		533010800	TUBE NUT D.10 M16*1,5
003		533039300	BICONE §10
003		532004700	BURNER COVER RING UR D128
003		533010900	NUT M14*1 H.4
003		533018500	
003		533039100	
003		532004400	BIG BURNER BODY 70LINE P.
003		533103500	AIR ADJUSTMENT BUSHING D22 EST.H57
003		533052301	JOINT FOR NOZZLE HOLDER
003		533101200	BURNER VENTURI UR
003		532005000	ELBOW FITTING OF BURNER VENTURI UR
003		533045700	THERMOCOUPLE M9*1 500
003		533038800	75 BY-PASS FOR 21S TAP
003		539018900	INDEX FOR KNOB

Page	Pos	Code	Description
003		533018500	FITTING FOR BICONE D.6 M10*1
003		533039100	BICONE §6
003		539022600	GRADUATED STICKER FOR KNOB
003		531032000	GAS COCK P.V.BY-PASS Ø075
003		536019800	BLACK KNOB §70 PIN §8*6,5
003		533091400	P.NOZZLE S100 UG.§20 PC90 LPG-FLUS
003		533091000	NOZZLE 0.100 §20
003		533014800	NOZZLE §135 CH12*14,0
003		533043400	NOZZLE §117 CH12*14 G-PC4 UR
003		533091500	PILOT NOZZLE S.100 §30 PC90 NAT.GAS
003		533091200	PILOT NOZZLE 0100 Ø35 PIL.PC
003		533055000	NOZZLE §205 CH12*14 G25 CW4
003		533014500	NOZZLE §225 CH12*14 OVEN GN 2/1
003		533055100	NOZZLE §215 CH12*14 L-CW4
004		531003300	TP-PLATE LIFTING HOOK
004		544426600	PLATE RING FOR TP-98G
004		541109701	UPPER PLATE TP-78G
004		546000901	SQUARE BRAID OF INSULATING MATERIAL
004		531033100	BURNER TP..-78G
005		533069600	BY PASS COCK §130 20S-21S
005		533039100	BICONE §6
005		533018500	FITTING FOR BICONE D.6 M10*1
005		539018900	INDEX FOR KNOB
005		531025500	GAS COCK 21S P.V.BY-PASS Ø130
005		533039300	BICONE §10
005		533010800	TUBE NUT D.10 M16*1,5
005		536019800	BLACK KNOB §70 PIN §8*6,5
005		539022600	GRADUATED STICKER FOR KNOB
005		533010900	NUT M14*1 H.4
005		533052301	JOINT FOR NOZZLE HOLDER
005		533023600	TAP PLUG §10 M16*1, 5CH19
005		537002800	PIEZOELECTRIC IGNITION M18
005		533085200	
005		537008300	ROUND PLUG §2,4- LONG ELECTRODE
005		533039400	THERMOCOUPLE M9*1*850
005		533023200	"TARGET" PILOT + NIPPLE TC BRAC.90°
005		533023300	BICONE §6 ("TARGET" PILOT)
005		533018600	PLUG FITTING
005		547003200	HIGH-VOLTAGE CABLE TUBE.§2 L=500
005		533020500	NOZZLE 0.140 §19
005		533057700	NOZZLE §130A CH12*30 F-BRF74
005		533019600	NOZZLE §165 CH12*30 MH-FT5 H-FT6
005		533057600	NOZZLE §115A CH12*30 G-BRF74
005		533046200	NOZZLE §150 CH12X30 L-BR TP
005		533020600	NOZZLE 0.140 §27
005		533047400	NOZZLE §195 CH12*30 M-BM8
005		533057500	NOZZLE §260 CH12X30
005		533047300	NOZZLE §215 CH12*30 L-BM8
005		533032801	NOZZLE §280 CH12*30 M-CPM
005		533047500	NOZZLE §205 CH12*30 ML-BM-8G
005		533032001	NOZZLE §270 CH12*30 MH-CPM