

TAV. 207 STRUTTURA STRUCTURE STRUCTURE STRUKTUR

	Codice	Denominazione	Denomination	Denomination	Bezeichnung	FGC00	FGP00	FMM00/061
1	GAFOC00056	Cassone forno	Caisson du four	Oven body	Ofenshublade	●	●	●
2	RTCU700002	Attacco griglia laterale	Attaque latérale	Lateral connection	Seitenanschluss	●	●	●
3	PAFOC00051	Disco scarico condensa	Disque évacuation condensation	Moisture drain disk	Kondenswasserablassscheibe	●	●	●
4	GAFOC00030	Cerniera superiore porta	Charnière supérieure	Upper hinge	Linke Türangel	●	●	●
5	GAFOC00031	Cerniera inferiore porta	Charnière inférieure	Lower door hinge	Untere Türangel	●	●	●
6	MPGOM03P00	Guarnizione vetro porta	Guarniture porte	Oven door gasket	Türdichtung	●	●	●
7	GAFOC00001	Porta forno	Porte du four	Oven door	Ofentür	●	●	●
8	RTFOC00008	Cristallo porta forno	Verre porte four	Oven door glass	Ofentürglas	●	●	●
9	RTFOC00007	Maniglia serratura	Poignée porte four	Oven door handle	Ofentürgriff	●	●	●
10	PAFOC00008	Controporta forno	Contre porte du four	Oven counter door	Gegentür	●	●	●
11	PAFOC00007	Protezione serratura porta	Protection de la serrure	Lock guard	Schlosschutz	●	●	●
12	PAFOC00085	Prolunga sinistra facciata	Rallonge gauche facade	Left facade extension	Verlängerung Linke Front	●	●	●
13	RTFOC00093	Guarnizione porta forno	Guarniture porte du four	Oven door gasket	Türdichtung	●	●	●
14	GAFOC00048	Cassetto	Tiroir	Drawer	Kasten	●	●	●
15	PAFOC00181	Traversa antigoccia	Traverse anti-goutte	Anti-drip crosspiece	Tropfschutzquerstange	●	●	●
16	PAFOC00084	Prolunga destra facciata	Rallonge droite facade	Right facade extension	Verlängerung Rechte Front	●	●	●
17	PAFOC00080	Coprilana inferiore	Panneau couvre isolant	Insulating panel cover	Isoliermaterialverkleidung	●	●	●
18	PACU800150	Pannello isolante	Panneau isolant	Insulating panel	Isoliertafel	●	●	●
19	GAFOC00059	Basamento	Soubassement	Base	Untergestel	●	●	●
20	GAFOC00057	Cruscotto	Panneau de contrôle	Control panel	Stirnbrett	●	●	●
21	RTFOC00035	Microinterruttore	Microswitch	Microswitch	Microswitch	●	●	●
22	PAFOC00023	Coprilana destro	Panneau couvre isolant	Insulating panel cover	Isoliermaterialverkleidung	●	●	●
23	RTFOC00086	Piedino	Pied	Foot	Inos-Fuss	●	●	●
24	PAFOC00082	Fianco inox	Côté inox	Inox side	Inox-Seite	●	●	●
25	GAFOC00019	Supporto ventola	Support ventilateur	Fan support	Laufradsupport	●	●	●
26	PAFOC00081	Coprilana inf. posteriore	Panneau couvre isolant	Insulating panel cover	Isoliermaterialverkleidung	●	●	●
27	PAFOC00024	Coprilana posteriore	Panneau couvre isolant	Insulating panel cover	Isoliermaterialverkleidung	●	●	●
28	PAFOC00083	Posteriore inox	Panneau postérieur inox	Inox back panel	Inox-Rückwand	●	●	●
29	PAFOC00022	Coprilana sinistro	Panneau couvre isolant	Insulating panel cover	Isoliermaterialverkleidung	●	●	●
30	PAFOC00136	Protezione comp. elettrici	Protection composant électriques	Electrical components guard	Schutz elektrischen Komponenten	●	●	●
31	PAFOC00141	Coprilana superiore	Panneau couvre isolant	Insulating panel cover	Isoliermaterialverkleidung	●	●	●
32	GAFOC00058	Coperchio	Couvercle	Cover	Topfdeckel	●	●	
32	GAFOC00086	Coperchio	Couvercle	Cover	Topfdeckel			●
33	GAFOC00005	Serratura porta forno	Serrure porte four	Over door lock	Ofentürschloss	●	●	●
34	RTFOC00057	Zoccolo centrale serratura	Prise centrale serrure	Central connection lock	Mittlerer Anschluss	●	●	●
35	RTFOC00005	Zoccolo esterno serratura	Prise extérieure serrure	External connection lock	Ausserer Anschluss	●	●	●
36	RTFOC00009	Gancio fisso serratura	Crochet fixe de la serrure	Lock fixed hook	Fester Schlossnaken	●	●	●
37	RTBF800021	Gommino porta forno	Bouchon de la porte	Door rubber cap	Türgummi	●	●	●
38	RTFOC00202	Guarnizione portalamпада	Garniture	Gasket	Dichtung	●	●	●
39	RTFOC00201	Vetro portalamпада	Verre protège ampoule	Lamp-holder glass	Leuchtenhalterungsglas	●	●	●
40	RTFOC00037	Lampada 25W 220V.	Ampoule 25W 220V	Lamp 25W 220V	Leuchte 25W 220V	●	●	●
41	RTFOC00036	Portalamпада	Douille	Lamp-holder	Leuchtenhalterung	●	●	●
42	RTFOC00060	Asta posteriore scarico cond.	Antenne arriere	Rear rod	Hinterere stange	●	●	●
43	RTFOC00061	Asta trasversale scarico cond.	Antenne transversale	Transverse rod	Querstange	●	●	●
44	RTFOC00056	Manopola scarico condensa	Manette évacuation condens.	Moisture drain knob	Drehknopf Kondenswasserablass	●	●	●
45	RTFOC00062	Asta anteriore scarico cond.	Antenne avant	Front/rod	Vordere stange	●	●	●
46	RTFOC00116	Tubo di collegamento infer.	Tuyon de branchement inférieur	Lower connection hose	Unteres Verbindungsrohr	●	●	●
47	RTFOC00117	Tubo di collegamento poster.	Tuyan de branchement postérieur	Rear connection hose	Hinteres Verbindungsrohr	●	●	●
48	RTFOC00059	Asta posteriore scarico cond.	Antenne arriere	Rear rod	Hinterere stange	●	●	●
49	RTFOC00152	Rampa scarico condensa	Rampe évacuation condensation	Moisture drain ramp	Kondenswasserablassrampe			●
49	RTFOC00052	Rampa scarico condensa	Rampe évacuation condensation	Moisture drain ramp	Kondenswasserablassrampe	●	●	
50	RTFOC00124	Gomito scarico condensa	Coude évacuation condensation	Moisture drain elbow	Kondenswasserablasskniestück	●	●	●
51	ACFCU00001	Camino antiventio	Chemineé antirefuleur	Chimney	Schornstein	●	●	●
52	PAFOC00092	Pannello inferiore	Panneau inférieur	Lowel panel	Untere Tafel	●	●	●
53	PAFOC00087	Deviatore fumi	Aiguilleur des fumées	Throttle	Rauchabweiser	●	●	●
54	MPISO00013	Pannello isolante	Panneau isolant	Insulating panel	Isoliertafel	●	●	●
55	GAFOC00061	Camino interno	Cheminée extérieure	External chimney	Aussenschornstein	●	●	●

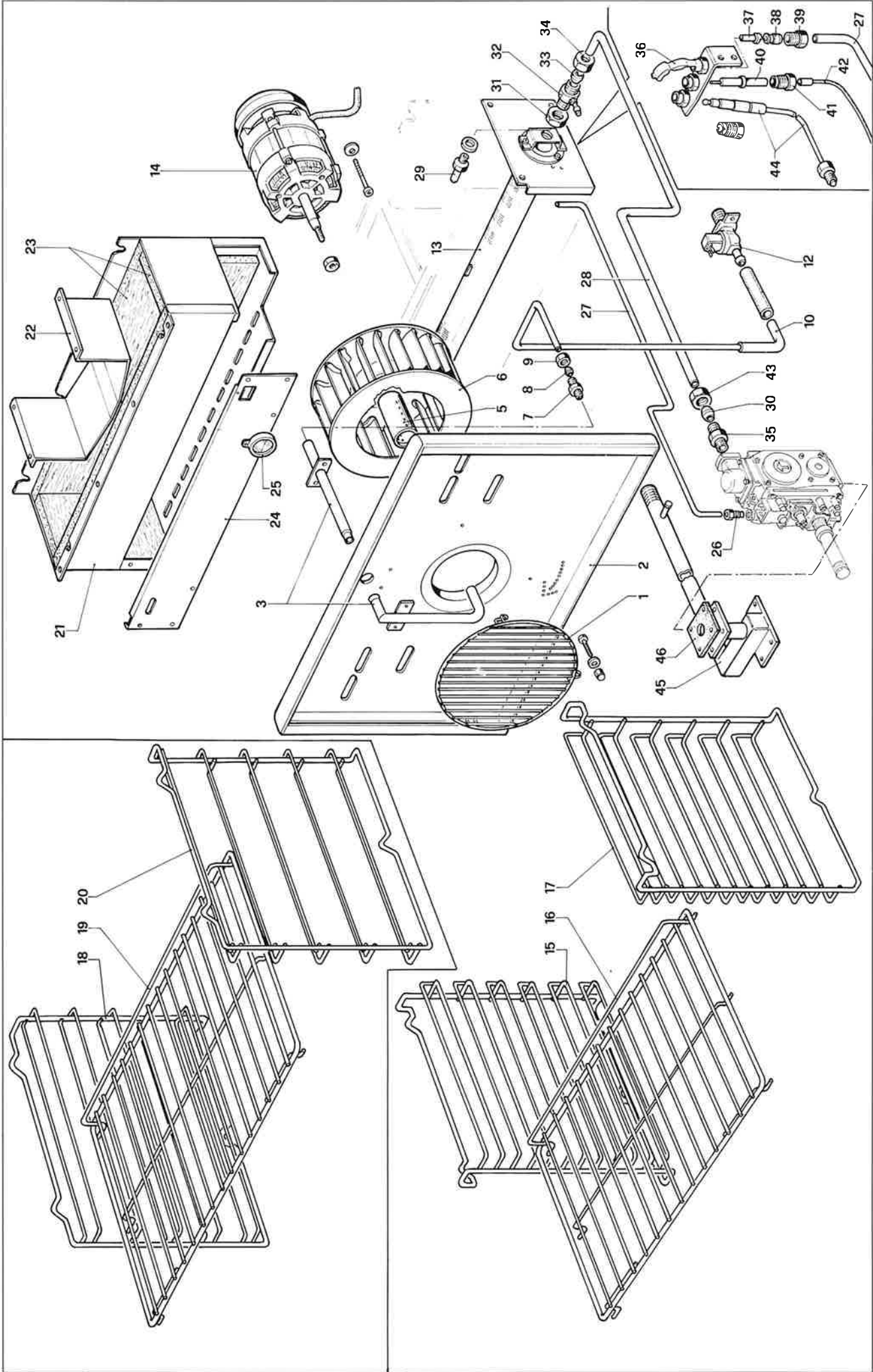

	Codice	Denominazione	Denomination	Denomination	Bezeichnung	FGC060/FGP050	FGM060/061	FGM060/061
1	RTFOC00014	Griglia protezione ventilatore	Grille ventilateur	Fan grille	Ventilatorgitter	●	●	
2	GAFOC00020	Convogliatore aria	Coiffe ventilateur air	Air duct	Luftförderer	●	●	
3	RTFOC00018	Umidificatore	Humidificateur	Humidifier	Befeuchter	●	●	
5	RTFOC00155	Nebulizzatore	Nébulisateur	Atomizer	Zerstäuber	●	●	
6	RTFOC00012	Girante ventilatore	Couronne mobile ventilateur	Fan wheel	Ventilatorlaufrad	●	●	
7	RTFOC00019	Iniettore umidificatore	Injecteur humidificateur	Injecteur for humidifier	Einspritzer für Befencter	●	●	
8	RTC800183	Bicono Ø 6	Bicone pour tube Ø 6	Bicone for pipe Ø 6	Zweikegel Ø 6	●	●	
9	RTFOC00020	Calotta per tubo Ø 6	Ecrou pour tube Ø 6	Nut for pipe Ø 6	Mutter für Schlauch Ø 6	●	●	
10	RTFOC00021	Tubo alimentazione umidificatore	Tube alimentation	Feeding pipe	Versorgungsrohr	●	●	
12	RTFOC00022	Elettrovalvola	Electrovanne	Solenoid valve	E-Ventil	●	●	
13	GAFOC00064	Briatore	Brûleur	Burner	Brenner	●	●	
14	RTFOC00011	Motore elettrico	Moteur électrique	Electric motor	E-Motor	●	●	
15	RTFOC00015	Griglia laterale sinistra (FGC060)	Grille latérale gauche (FGC060)	Left lateral grate (FGC060)	Linke Seitenrost (FGC060)	●		
15	RTFOC00180	Griglia laterale sinistra	Grille latérale gauche	Left lateral grate	Linke Seitenrost		●	
16	RTFOC00017	Griglia forno (FGC060)	Grille du four (FGC060)	Oven grate (FGC060)	Ofenrost (FGC060)	●		
16	RTFOC00175	Griglia forno	Grille du four	Oven grate	Ofenrost		●	
17	RTFOC00016	Griglia laterale destra (FGC060)	Grille latérale droite (FGC060)	Right lateral grate (FGC060)	Rechte Seitenrost (FGC060)	●		
17	RTFOC00176	Griglia laterale destra	Grille latérale droite	Right lateral grate	Rechte Seitenrost		●	
18	RTFOC00081	Griglia laterale sinistra (FGP050)	Grille latérale gauche (FGP050)	Left lateral grate (FGP050)	Linke Seitenrost (FGP050)	●		
19	RTFOC00083	Griglia forno (FGP050)	Grille du four (FGP050)	Oven grate (FGP050)	Ofenrost (FGP050)	●		
20	RTFOC00082	Griglia laterale destra (FGP050)	Grille latérale droite (FGP050)	Right lateral grate (FGP050)	Rechte Seitenrost (FGP050)	●		
21	GAFOC00063	Camera di combustione	Chambre de combustion	Combustion chamber	Brennkammer	●	●	
22	PAFOC00104	Deflettore bruciatore	Défecteur pour brûleur	Burner deflector	Deflektor	●	●	
23	MPIS00012	Pannello isolante	Panneau isolant	Insulating panel	Isolierplatte	●	●	
24	PAFOC00101	Coperchio camera combustione	Panneau antérieur chambre comb.	Combustion chamber face	Brennkammervorderwand	●	●	
25	RTBF900054	Visore con retro	Doville	Viewer	Monitor	●	●	
26	RTC800217	Raccordo e bicono Ø 6	Ecrou et bicone Ø 6	Nut and bicone Ø 6	Mutter und Zweikegel Ø 6	●	●	
27	PAFOC00098	Tubo alimentazione pilota	Tube pour veilleuse	Pilot pipe	Pilotbrennerrohr	●	●	
28	PAFOC00097	Tubo alimentazione bruciatore	Tube alimentation du brûleur	Burner feeding pipe	Brennerversorgungsrohr	●	●	
29	RTCP800016	Iniettore Ø 1.70 per GPL	Injecteur Ø1.70 pour GPL	Injector LPG Ø1.70	Flüssiggas-Einspritzer Ø1.70	●	●	
29	RTFOC00102	Iniettore Ø 2.80 gas metano	Injecteur Ø2.80 pour méthane	Methane injector Ø2.80	Methangas-Einspritzer Ø2.80	●	●	
30	RTCP900088	Bicono Ø 14	Bicone Ø 14	Bicone Ø 14	Zweikegel Ø 14	●	●	
31	RTCP800013	Controdado 1/2"	Countre écrou 1/2"	Lock nut 1/2"	Gegenmutter 1/2"	●	●	
32	RTCP800012	Supporto iniettore	Support injecteur	Injector support	Einspritzerhalterung	●	●	
33	RTBF800137	Bicono Ø 14	Bicone Ø 14	Bicone Ø 14	Zweikegel Ø 14	●	●	
34	RTBF800015	Calotta Ø 14	Écrou pour tube Ø 14	Nut for pipe Ø 14	Mutter für Schlauch Ø 14	●	●	
35	RTCP900087	Nipples 1/2" - M20	Nipples 1/2" - M20	Nipples 1/2" - M20	Nippel 1/2" - M20	●	●	
36	RTCP800034	Corpo pilota	Corps veilleuse	Pilot body	Pilotbrenner	●	●	
37	RTCP800041	Iniettore pilota Ø 0,19 per GPL	Injecteur veilleuse Ø 0.19 pour GPL	L.P.G. pilot injector Ø 0.19	Flüssiggas-Einspritzer Ø 0.19	●	●	
37	RTCP800040	Iniettore Ø 0.36 gas metano	Injecteur veilleuse Ø 0.36 pour méth.	Methane pilot injector Ø 0.36	Methangas-Einspritzer Ø 0.36	●	●	
38	RTC800183	Bicono Ø 6	Bicone Ø 6	Bicone Ø 6	Zweikegel Ø 6	●	●	
39	RTC800182	Calotta Ø 6	Écrou pour tube Ø 6	Nut for pipe Ø 6	Mutter für schlauch Ø 6	●	●	
40	RTCP800033	Candela rotonda	Bugie d'allumage	Spark plug	Zündkerze	●	●	
41	RTC800215	Raccordo candela pilota	Raccord pour bugie veilleuse	Fitting for pilot spark plug	Anschlussstück	●	●	
42	RTFOC00128	Cavo accensione	Cable d'allumage	Lighting cable	Zündkabel	●	●	
43	RTCP900089	Calotta Ø 14	Écrou pour tube Ø 14	Nut for pipe Ø 14	Mutter für schlauch Ø 14	●	●	
44	RTFOC00241	Termocoppia cm. 100	Thermocouple cm. 100	Thermocouple 100 cm.	Thermoelement 100 cm.	●	●	
45	RTFOC00091	Rampa forno	Collecteur du four	Oven collector	Speiserampe	●	●	
46	RTFOC00100	Guarnizione rampa	Garniture	Gasket	Dichtung	●	●	

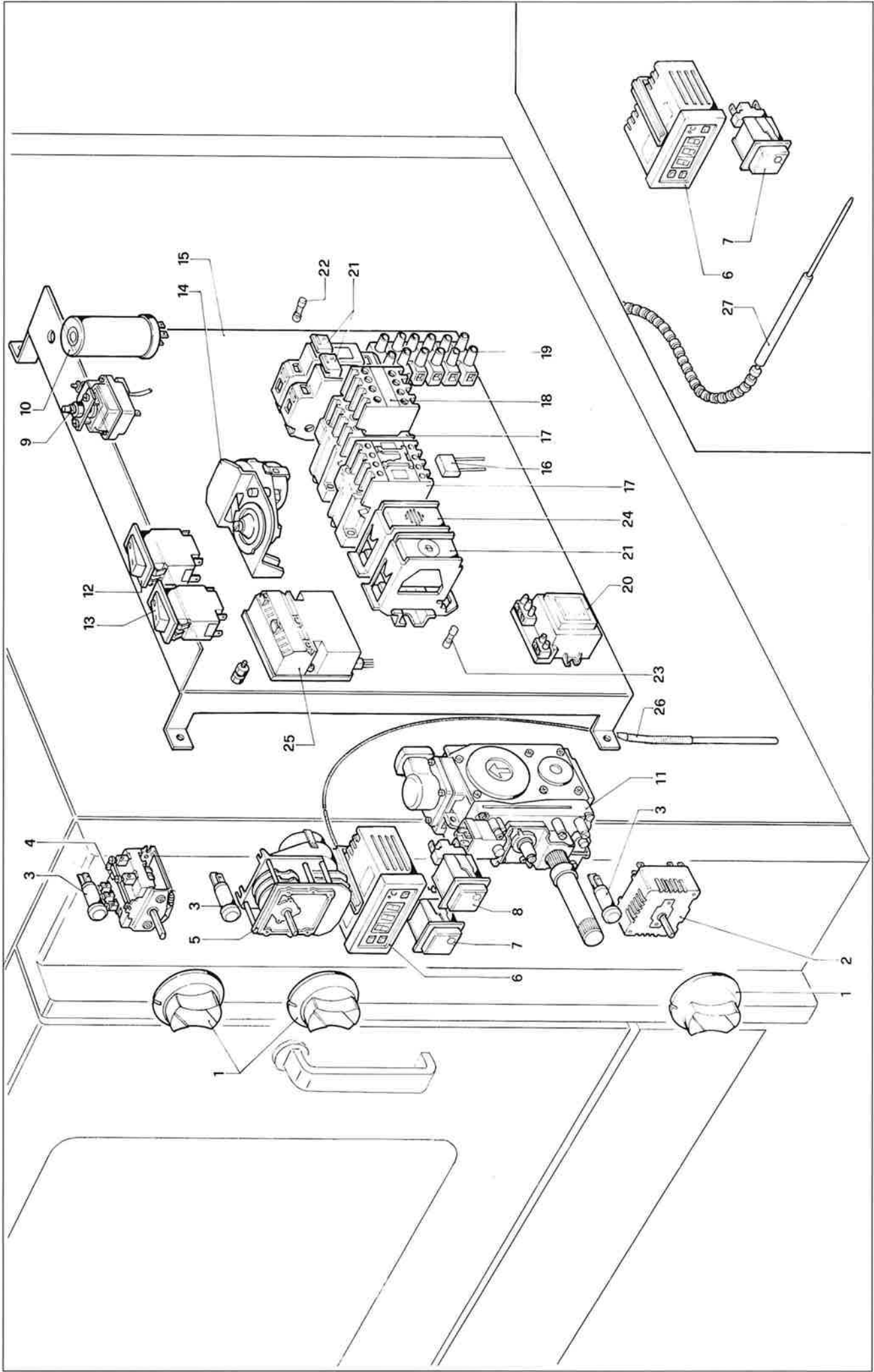

STAR CHEF

TAV. 209

TAV. 209 APPARECCHIATURE ELETTRICHE APPAREILLAGES ÉLECTRIQUES ELECTRICAL EQUIPMENT ELEKTROGERÄTE

	Codice	Denominazione	Denomination	Denomination	Bezeichnung	FGC060	FGP050	FGC100	FCP080
1	RTFOC00055	Manopola comando	Manette de commande	<i>Control knob</i>	Steuerdrehknopf	●	●	●	●
2	RTCU800066	Regolatore d'energia FCV 240 V.	Régulateur d'énergie	<i>Power regulator</i>	Energiescher Regler	●	●	●	●
3	RTCU900072	Lampada spia gialla	Lampe témoin jaune	<i>Yellow warning lamp</i>	Gelbe Kontrollenchtenbrine	●	●	●	●
4	RTFOC00031	Commutatore	Commutateur du four	<i>Oven commutator</i>	Kommutator	●	●	●	●
5	RTFOC00030	Timer	Timer	<i>Timer</i>	Timer	●	●	●	●
6	RTFOC00029	Termostato elettronico	Thermostat électronique	<i>Electronic thermostat</i>	Elektra-Thermostat	●	●	●	●
7	RTFOC00033	Pulsante 2 velocità	Bouton 2 vitesses	<i>Two-speed button</i>	Taste Zwei Geschwindig	●	●	●	●
8	RTFOC00032	Pulsante luce	Bouton lumière	<i>Light button</i>	Lichttaste	●	●	●	●
9	RTFOC00038	Termostato Limit	Thermostat Limit	<i>Limit thermostat</i>	Limit Thermostat	●	●	●	●
10	RTFOC00053	Condensatore	Condensateur	<i>Condenser</i>	Kondensator	●	●	●	●
11	RTFOC00095	Valvola gas	Valve gas	<i>Valve sit</i>	Gasventil	●	●	●	●
12	RTFOC00074	Termica 1,6 A	Interrupteur thermique 1,6 A	<i>Overload swith 1,6 A</i>	Thermoschutzschalter 1,6 A			●	●
12	RTFOC00045	Termica 3 A	Interrupteur thermique 3 A	<i>Overload switch 3 A</i>	Thermoschutzschalter 3 A	●	●		
13	RTFOC00129	Termica 0,6A	Interrupteur thermique 0,6 A	<i>Overload swith 0,6 A</i>	Thermoschutzschalter 0,6 A			●	●
13	RTFOC00044	Termica 0,8 A	Interrupteur thermique 0,8 A	<i>Overload switch 0,8 A</i>	Thermoschutzschalter 0,8 A	●	●		
14	RTFOC00042	Ciclatore 50 Hz	Cycleur 50 Hz	<i>Buzzer 50 Hz</i>	Taktvorrichtung 50 Hz	●	●	●	●
15	PAFOC00029	Supporto componenti elettrici	Support composant électriques	<i>Electrical components support</i>	Halterungelektrischen Komponenten	●	●	●	●
16	RTFOC00023	Antidisturbo radio	Antiparasitage radio	<i>Antijamming</i>	Furkenstörung	●	●	●	●
17	RTFOC00040	Relais FCV	Relais FCV	<i>Relais FCV</i>	Relais FCV	●	●	●	●
18	RTFOC00041	Contatti ausiliari	Contacts auxiliaires	<i>Auxiliary contacts</i>	Nebenkontakte	●	●	●	●
19	RTBF900045	Morsettiera 6 poli	Groupe de conn. des cables	<i>Terminal bloc 6 poles</i>	Klemmenbreit 6 Polig	●	●	●	●
20	RTFOC00039	Trasformatore 220 ÷ 12V	Trasformateur el. 220 ÷ 12V	<i>Electric trasformer 220 ÷ 12V</i>	Transformator 220 ÷ 12V	●	●	●	●
21	RTFOC00048	Portafusibile	Porte-fusible	<i>Fuse-holder</i>	Sicherungshalter	●	●	●	●
22	RTFOC00024	Fusibile 2,5 A	Fusible 2,5 A	<i>Fuse 2,5 A</i>	Schmelzsicherung 2,5 A	●	●	●	●
23	RTFOC00047	Fusibile 0,1 A	Fusible 0,1 A	<i>Fuse 0,1 A</i>	Schmelzsicherung 0,1 A	●	●	●	●
24	RTFOC00046	Ronzatore	Bourdonneur	<i>Buzzer</i>	Summer	●	●	●	●
25	RTF800129	Accenditore elettrico	Allumage électrique	<i>Electric lighting</i>	Elektrischer Anzünder	●	●	●	●
26	RTFOC00034	Termocoppia cm. 100	Thérmococuple cm. 100	<i>Thermocouple 100 cm.</i>	Thermoelement 100 cm.	●	●	●	●
27	RTFOC00130	Sonda al cuore cm. 55	Sonde thermique cm. 55	<i>Thermique probe 55 cm</i>	Wärmefühler 55 cm	●	●		
27	RTFOC00131	Sonda al cuore cm. 82	Sonde thermique cm. 82	<i>Thermic probe 82 cm.</i>	Wärmefühler 82 cm.			●	●