

DISHWASHER

ELECTROMECHANICAL SWITCHES
LOWER AND UPPER WASHING

TYPE: 9U

Accessories
BREAK TANK
BOOSTER PUMP
DVGW
COLD RINSE
WATER SOFTNER
DETERGENT DISPENSER
DRAIN PUMP

Spare parts manual

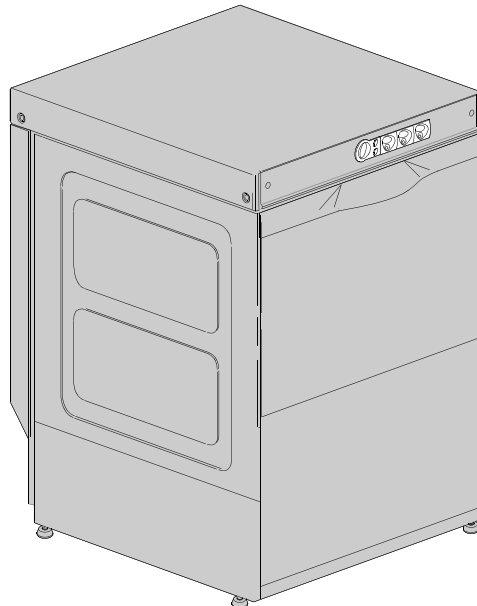

INFORMAZIONI GENERALI

Questo catalogo serve per richiedere con esattezza le parti di ricambio

Nelle ordinazioni indicare:

1) il numero dei codici dei particolari seguito dalla descrizione e la quantità desiderata;

2) Il codice alfa-numeric presente nella seconda colonna della tabella ;

I disegni delle parti di ricambio sono solo indicativi e non rappresentano il pezzo in oggetto.

I dati contenuti in questo catalogo sono indicativi e possono essere soggetti a modifiche senza impegno di preavviso.

ALLGEMEINE INFORMATIONEN

Dieser Ersatzteilkatalog dient zur genauen Angabe der Teile bei Ersatzteilbestellungen.

Bei Ersatzbestellung ist folgendes anzugeben:

1) Die Bestellnummer der Ersatzteile mit der entsprechenden Beschreibung genaue Menge;

2) Der alpha-numerischer Code auf der zweiten Reihe in dein Spalte;

Die Zeichnungen der Ersatzteile sind nur als Hinweise gedacht und stellen nicht das betroffene Teil dar.

Bei den im Katalog angeführten Daten handelt es sich um Anhaltsdaten, die jederzeit, ohne Vorankündigung, geändert werden können.

GENERAL INFORMATION

The present spare parts order exactly the right spare parts

When ordering specify:

1) the part's code number followed by its description and quantity needed;

2) The alpha-numeric code is in the second column in the chart;

Spare parts drawings are general and do not represent the part.

The contents of this catalogue are general and can undergo changes without prior notice.

INFORMACIONES GENERALES

El presente catálogo sirve para pedir con exactitud las partes de repuesto

En los pedidos se debe indicar:

1) el número de código de la parte y a continuación la descripción cantidad deseada;

2) El código alfanumerico presente en la signada columna de la tabla;

Los diseños de las partes de recambio son solo indicativos y no representan la pieza en cuestión.

Los datos contenidos en el presente catálogo son indicativos y pueden modificarse sin aviso previo.

INFORMATIONS GENERALES

Ce catalogue permet de commander correctement les pièces détachées

Les commandes doivent être passées en indiquant:

1) le numero de code des pièces détachées suivi de leur description quantité désirée;

2) le code alphanumérique dans la deuxième colonne du tableau;

Les plans des pièces détachées sont fournis seulement à titre indicatif et ne représentent pas la pièce concernée.

Les données de ce catalogue sont citées seulement à titre indicatif et peuvent être l'objet de modifications sans avis préalable.

**ESEMPIO
EXAMPLE
EXEMPLE
BEISPIEL**

Rif.	Codici
MODULE:Particolari	
10505	540903
10510	540908
10515	15065/A
10520	540086
10525	540028

Note

Tutte le informazioni riportate si intendono aggiornate alla data di stampa. Il Produttore si riserva il diritto di apportare qualsiasi modifica richiesta dallo sviluppo evolutivo dei suddetti prodotti.

Per la sicurezza, la garanzia, l'affidabilità ed il valore della lavastoviglie usa solo ricambi originali.

Attenzione

Questo libretto è parte integrante della lavastoviglie e, in caso di passaggio di proprietà, deve essere consegnato al nuovo acquirente.

Remarque

Toutes les informations contenues dans ce manuel s'entendent mises à jour à la date d'impression. En raison du développement constant de ses produits, usine se réserve le droit d'apporter à tout instant les modifications qu'elle jugera utiles.

Pour la sécurité, la garantie, la fiabilité et la valeur de votre lavevaisselles n'utilisez que des pièces de rechange d'origine.

Attention

Ce manuel doit être considéré comme partie intégrante de la la lavevaisselles, en cas de transfert de propriété, doit toujours être remis au nouveau propriétaire.

Note

The information contained herein is valid at the time of going to print. The Company reserves the right to make any changes required by the future development of the above-mentioned products.

For your safety, as well as to preserve the warranty reliability and worth of your dishwashers, use original spare parts only.

Warning

This manual forms an integral part of the dishwashers and - if a transfer of title occurs - must always be handed over to the new owner.

Hinweis

Die Der Hersteller behält sich das Recht vor, jegliche, durch eine Weiterentwicklung der genannten Produkte bedingte Änderungen vornehmen zu können.

Verwenden Sie für Ihre Sicherheit, die Garantie, die Zuverlässigkeit und den Wert Ihrer machine originale Ersatzteile.

Achtung

Diese Betriebsanleitung ist Bestandteil des machine und muss bei seinem Weiterverkauf dem neuen Besitzer ausgehändigt werden.

1. Spare parts

General body parts.....	7
Lockup system	9
Control panel	11
Control electric components.....	13
Solenoid valve group	15
Solenoid valve group	17
Break Tank	19
Booster pump.....	21
DVGW	23
Water softner group.....	25
Shining product dosing device group .	27
Shining product dosing device group .	29
Boiler group	31
3 ways derivation	33
Wash pump	35
Wash pump	37

Dosing device group	39
Dosing device group	41
Drain pump group.....	43
Pressure switch group with air trap ...	45
Turret group with rotating arms	47

1.1 Voltage codes

Voltage code	Voltage
A	3/N/PE~400/230V 50Hz
B	~250V 16A 50Hz
C	3/N/PE~380/220V 50Hz
D	3/PE~200V 50-60Hz
F	2/PE 220-240V 50Hz
G	3/N/PE~415/240V 50Hz
H	3/PE~230V 50Hz
I	3/PE~220V 60Hz
J	3/PE~380 50Hz
K	3/PE~400V 50Hz
L	3/PE~415V 50Hz
M	3/PE~440V 60Hz
N	3/PE~460V 60Hz
O	3/PE~480V 60Hz
P	1/N/PE~220-240V 50Hz
R	2/PE~220-230V 60Hz
S	3/N/PE~400/230V 50Hz
T	3/PE~230V 60Hz

1.2 Product codes

Product code	Full name
Model codes	
em	ELECTROMECHANICAL SWITCHES
ls	LOWER AND UPPER WASHING
Type codes	
9U	9U
Accessory codes	
bt	BREAK TANK
pap	BOOSTER PUMP
dvgw	DVGW
fs	COLD RINSE
d	WATER SOFTNER
dde	DETERGENT DISPENSER
ps	DRAIN PUMP

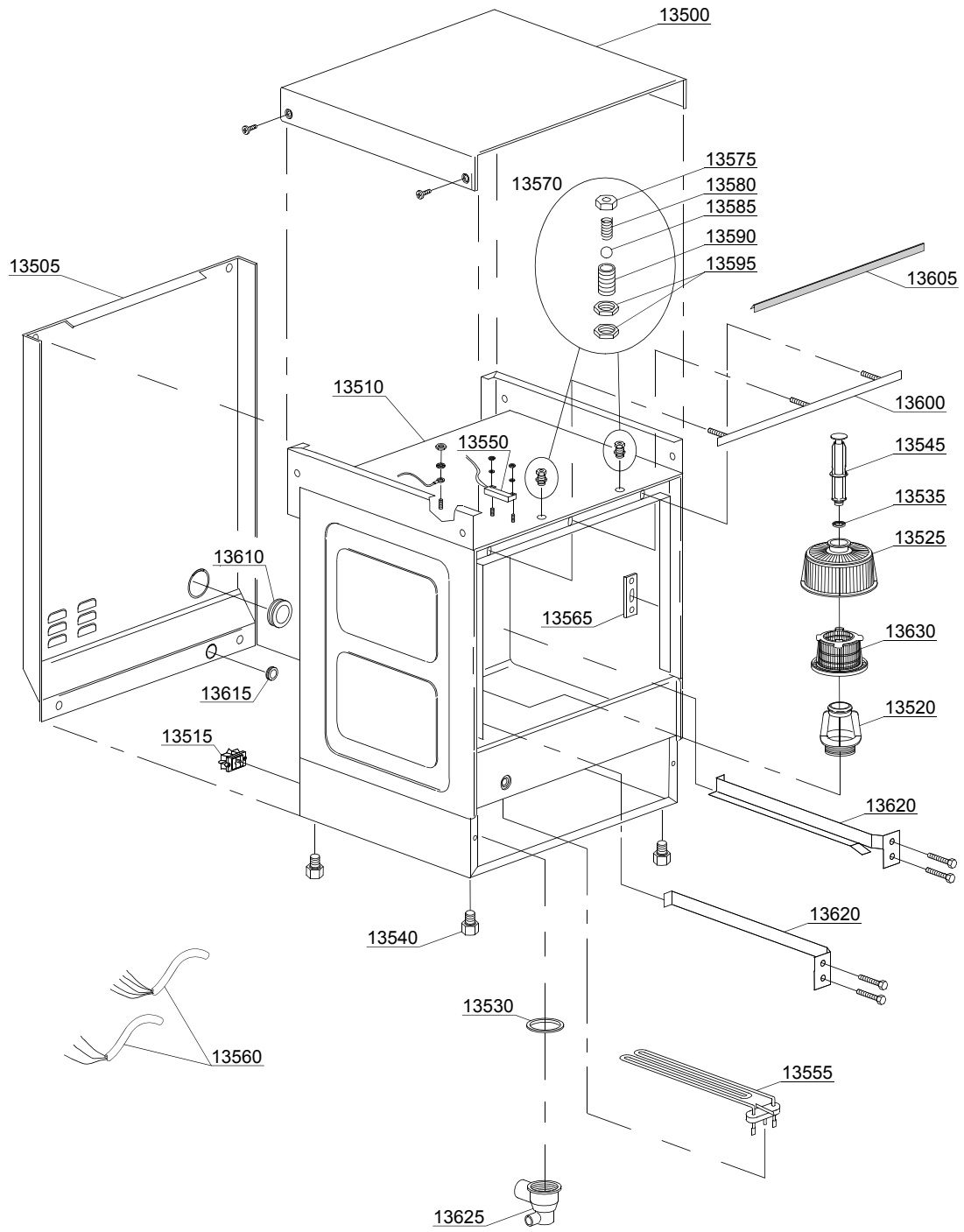

01_015_e

Spare parts

ID	P-code	Model	Type	Accessory	Voltage	Description
MODULE:General body parts						
13500	500904		9U			Cover
13505	500909		9U			Back panel
13510	500900		9U			Body
13510	500900/A		9U	ws		Body
13515	15065/A		9U			Cable-fastener with screw
13520	500607		9U			Ferrule with filter
13525	500616		9U			Suction filter
13530	80208		9U			95x75x3 gasket
13535	13021		9U			DEM 40 gasket
13540	10850		9U			Foot
13545	500618		9U			Overflow pipe
13550	10778		9U			Reed magnet
13555	150047		9U			2,7KW heating element
13555	15047/E		9U			2,5KW heating element
13555	16035/B		9U			1,6KW heating element
13560	15118		9U			5x2,5x2500 cable
13560	15104/B		9U			3x4x2500 cable
13560	10713		9U			3x2,5x2500 cable
13560	15145		9U			4x4x2500 cable
13565	150401		9U			Door rod slide
13570	10775		9U			Door jack assembly
13575	10802		9U			Door jack locknut
13580	10777		9U			Spring for door hook
13585	10776		9U			Sphere
13590	10803		9U			Door jack body
13595	10801		9U			Door jack nut
13600	150921		9U			Door gasket angular
13605	135205		9U			Door gasket
13610	13317		9U			Ø40mm fairlead
13615	13323		9U			Ø13mm fairlead
13620	500902		9U			Right/left internal slide
13625	500606		9U			Right side scrap tray
13630	500600		9U			Interior filter with rack

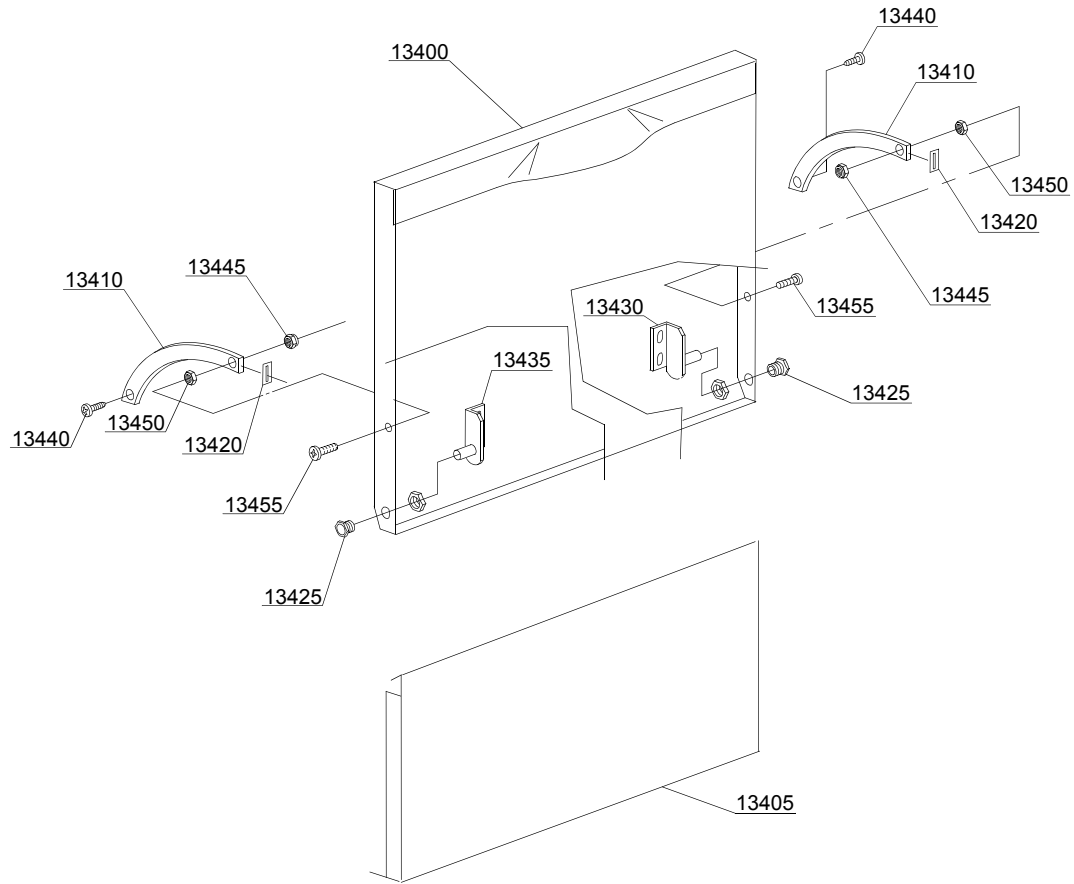

02_112_e

ID	P-code	Model	Type	Accessory	Voltage	Description
MODULE:Lockup system						
13400	500933		9U			Door
13405	500903		9U			Lower door
13405	500912		9U			Eurochef lower door
13410	150221		9U			Right/left door rod
13420	135222		9U			Hinge door seal
13425	11835/A		9U			Brass bush
13430	150210		9U			Right hinge door
13435	150211		9U			Left hinge door
13440	11121		9U			Self-tapping screw
13445	11721		9U			M6 self-locking nut
13450	11706		9U			M6 stainless steel nut
13455	11111		9U			Stainless steel screw

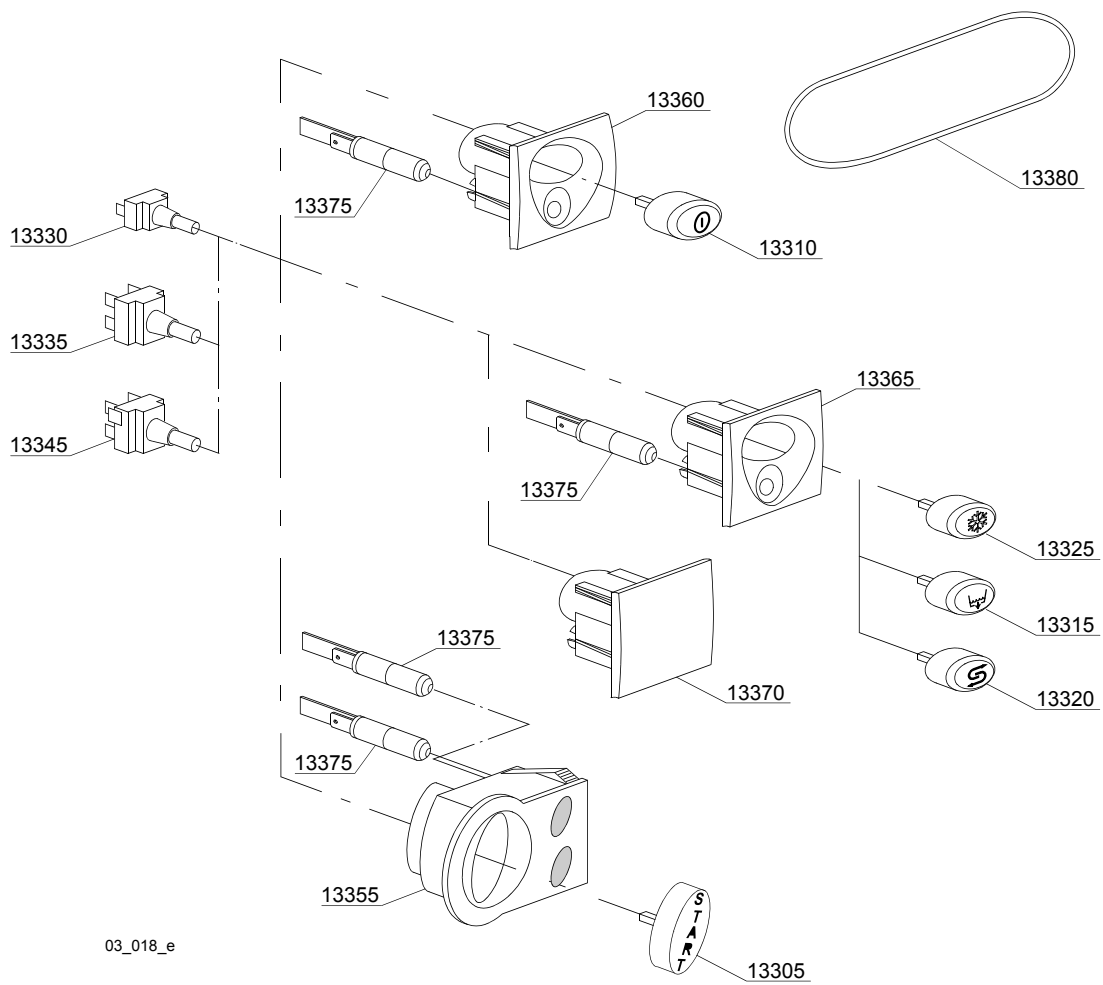
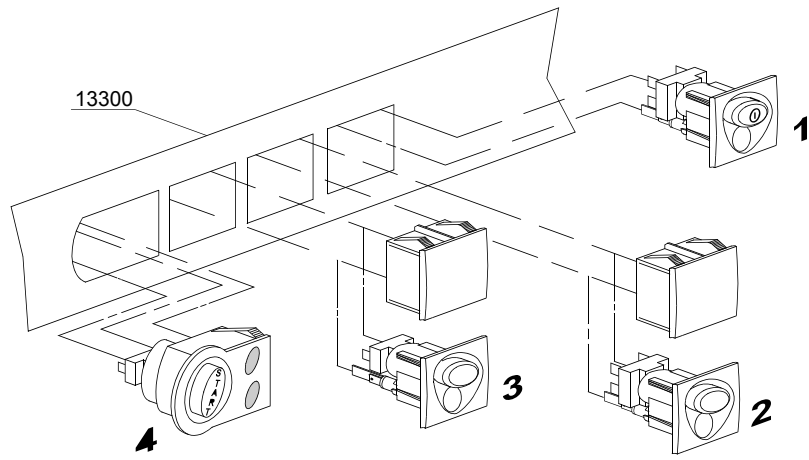

03_018_e

ID	P-code	Model	Type	Accessory	Voltage	Description
MODULE:Control panel						
13300	500931		9U			Control panel GS 50
13300	500935		9U			Control panel GS 50
13305	89347		9U			Start key
13310	89340		9U			ON-OFF key
13315	89343		9U	dp		Drain pump key
13320	89345		9U	ws		Regeneration key
13325	89344		9U	cr		Hot/cold key
13330	15813		9U			16A unipolar push button
13335	15812		9U			16A switch
13335	15800		9U			16A bipolar push button
13345	15811		9U			16A bipolar switch
13345	15811/A		9U			16A bipolar switch push button
13355	89301		9U			Start key support
13360	89304		9U			Key support
13365	89302		9U	dp,ws,cr		Key support
13370	89303		9U			Closed support
13375	15826		9U			Pilot light
13380	89333		9U			OR gasket

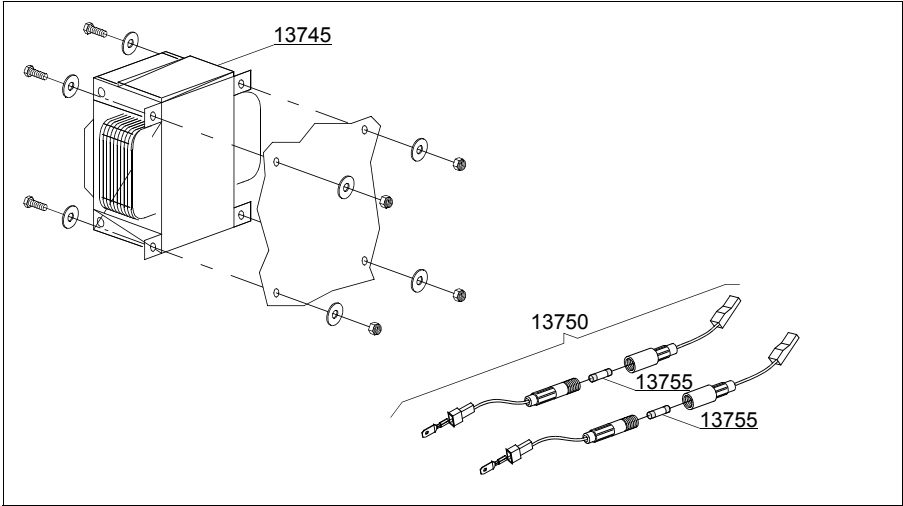
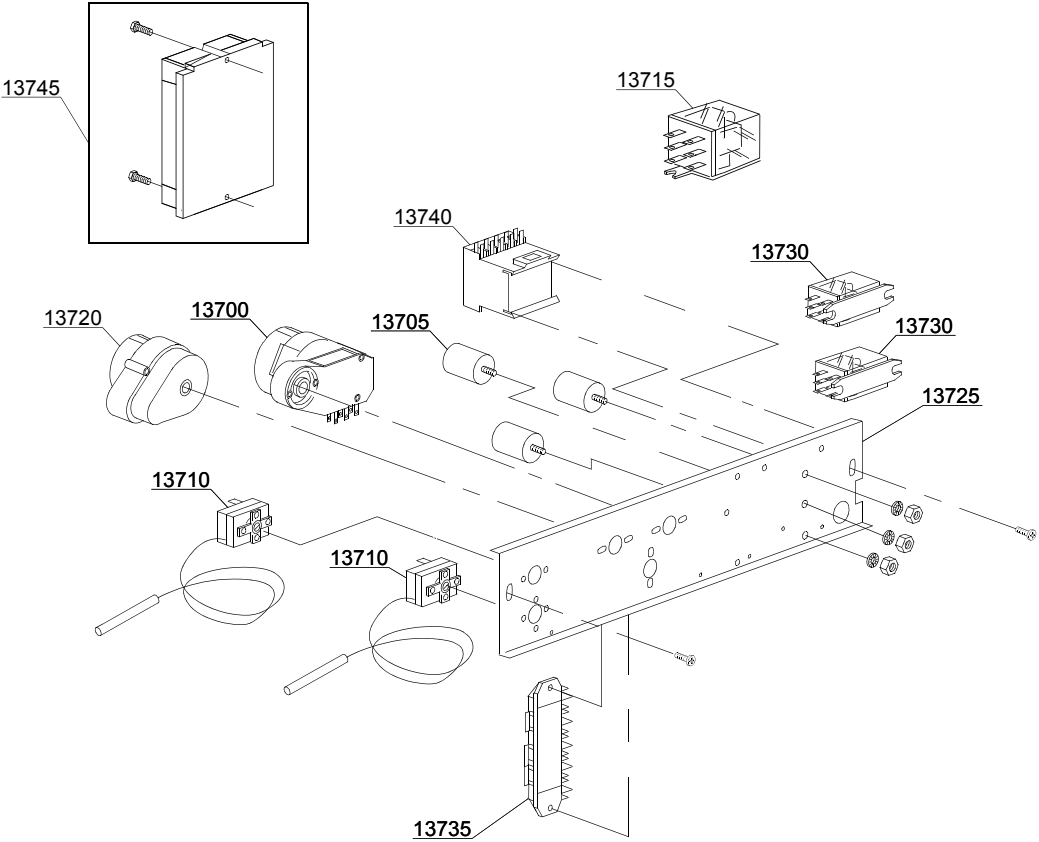

Spare parts

ID	P-code	Model	Type	Accessory	Voltage	Description
MODULE:Control electric components						
13700	10708/L		9U		A	120" timer
13700	10708/B		9U			120" timer - 220Vac 60Hz
13700	10708/E		9U			90" timer with thermostop
13700	10708/T		9U			120" timer with thermostop
13705	15149		9U			Low noise filter
13710	10707/1		9U			0-90°C thermostat
13715	16047		9U	dp		16A tripolar relay
13720	16064/A		9U	ws		Regeneration timer
13725	500910		9U			Electric components panel
13730	15620		9U			Bipolar relay in deviation
13730	15620/A		9U			Bipolar relay in deviation - 110Vac 60Hz
13735	500550		9U			3 poles terminal board
13735	500551		9U			6 poles terminal board
13740	15086		9U			Remote control switch 230V 50/60Hz 4C
13740	15086/B		9U			Remote control switch
13740	10300055		9U			25A 110Vac remote control switch
13745	50553		9U			3 Times electronic timer 120"220Va 60 Hz

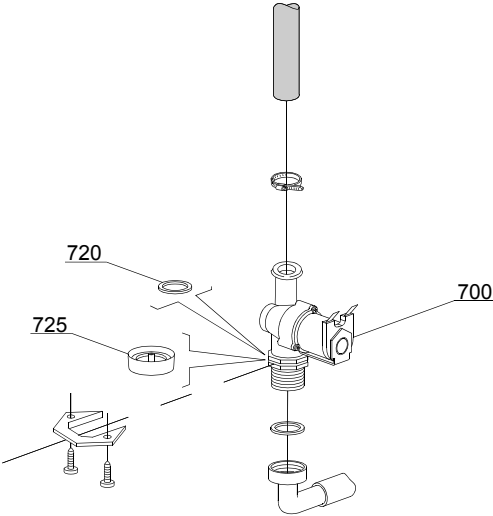

05_002_e

Spare parts

ID	P-code	Model	Type	Accessory	Voltage	Description
MODULE: Solenoid valve group						
700	10703		9U			Single solenoid valve
700	10703/A		9U			Single solenoid valve - 110Vac
720	N.C.		9U			Pression reducing valve

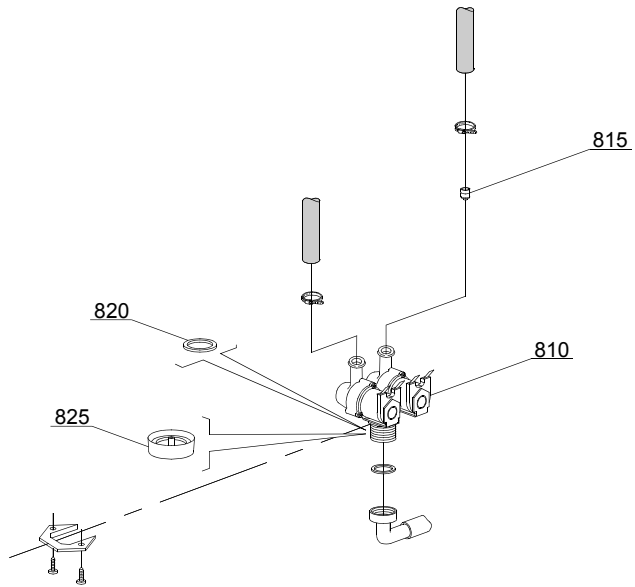

05_003_e

Spare parts

ID	P-code	Model	Type	Accessory	Voltage	Description
MODULE: Solenoid valve group						
810	15098		9U	cr,ws		Double solenoid valve - Ø10
815	15115		9U	cr,ws		Green presson solenoid valve
820	N.C.		9U	cr,ws		Pression reducing valve

06_002_e

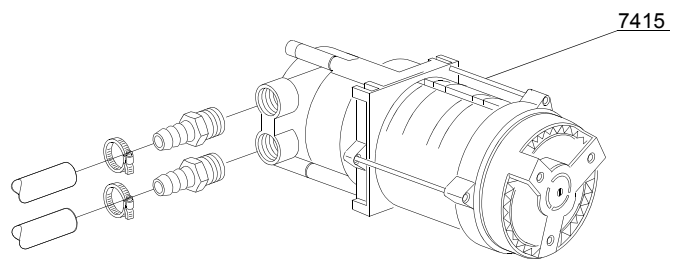
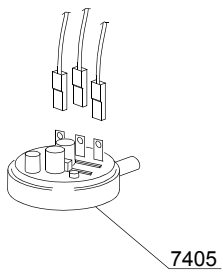
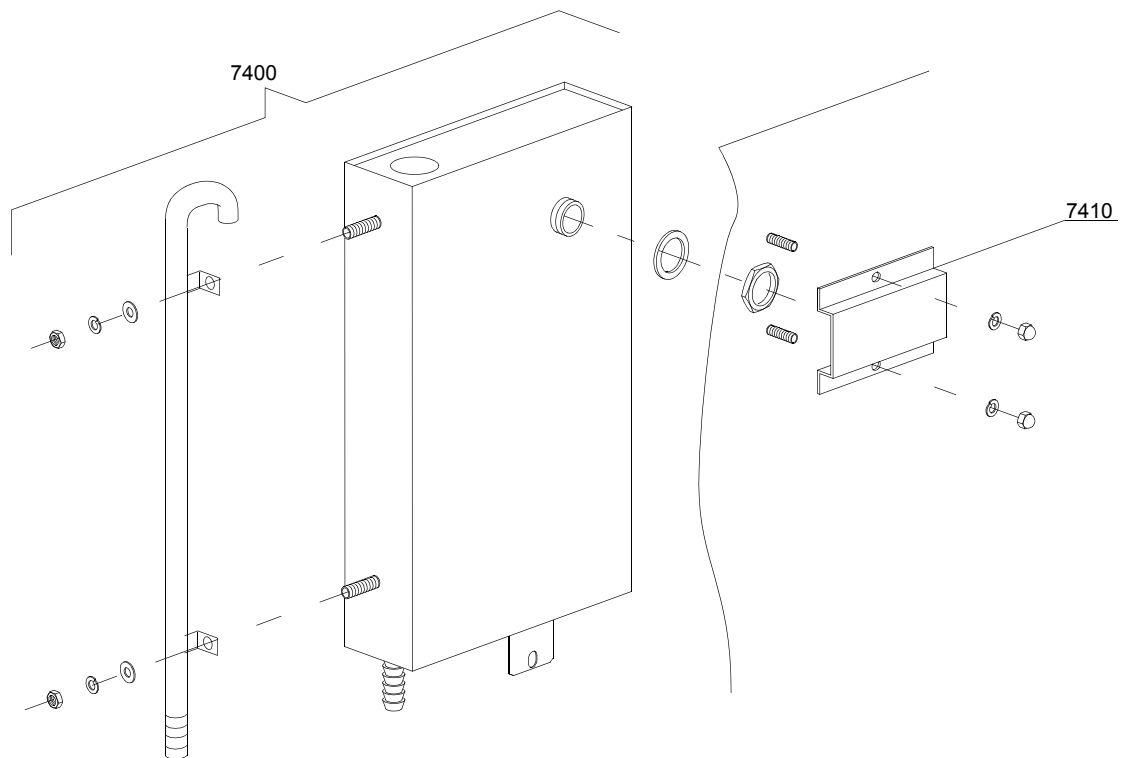

Spare parts

ID	P-code	Model	Type	Accessory	Voltage	Description
MODULE:Break Tank						
7400	15735		9U	bt		Break tank assembly
7405	10706/A		9U	bt		47-27 pressure switch
7410	15738		9U	bt		Hole protection
7415	15100/D		9U	bt		Booster pump

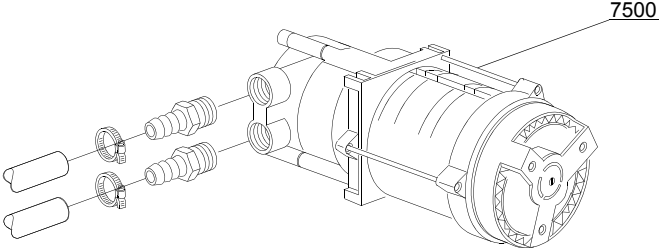

07_003_e

Spare parts

ID	P-code	Model	Type	Accessory	Voltage	Description
MODULE:Booster pump						
7500	15100/D		9U	bp		Booster pump

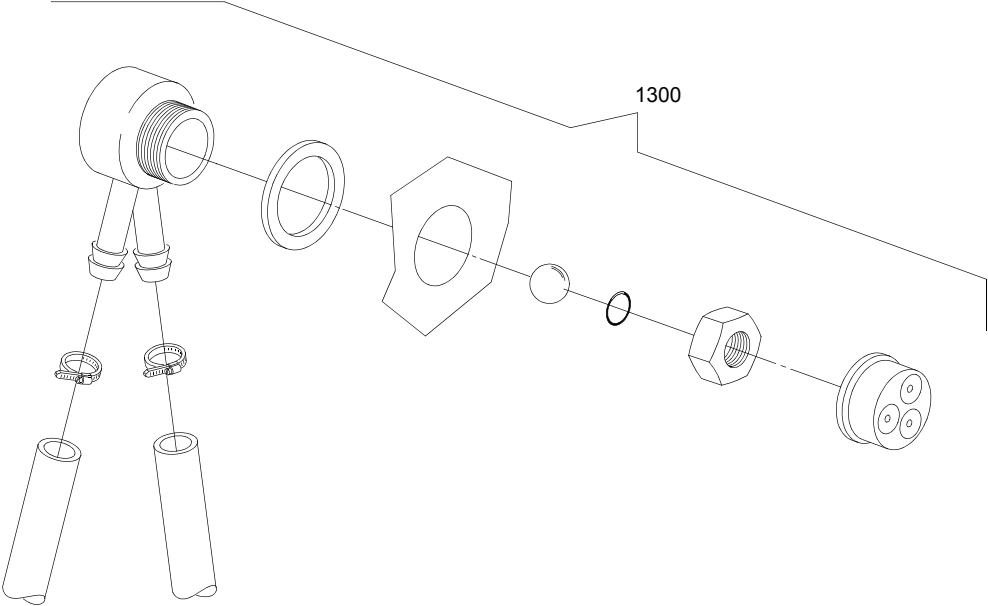

08_005_e

Spare parts

ID	P-code	Model	Type	Accessory	Voltage	Description
MODULE:DVGW						
1300	999900006		9U	dvgw		DVGW assembly

09_001_e

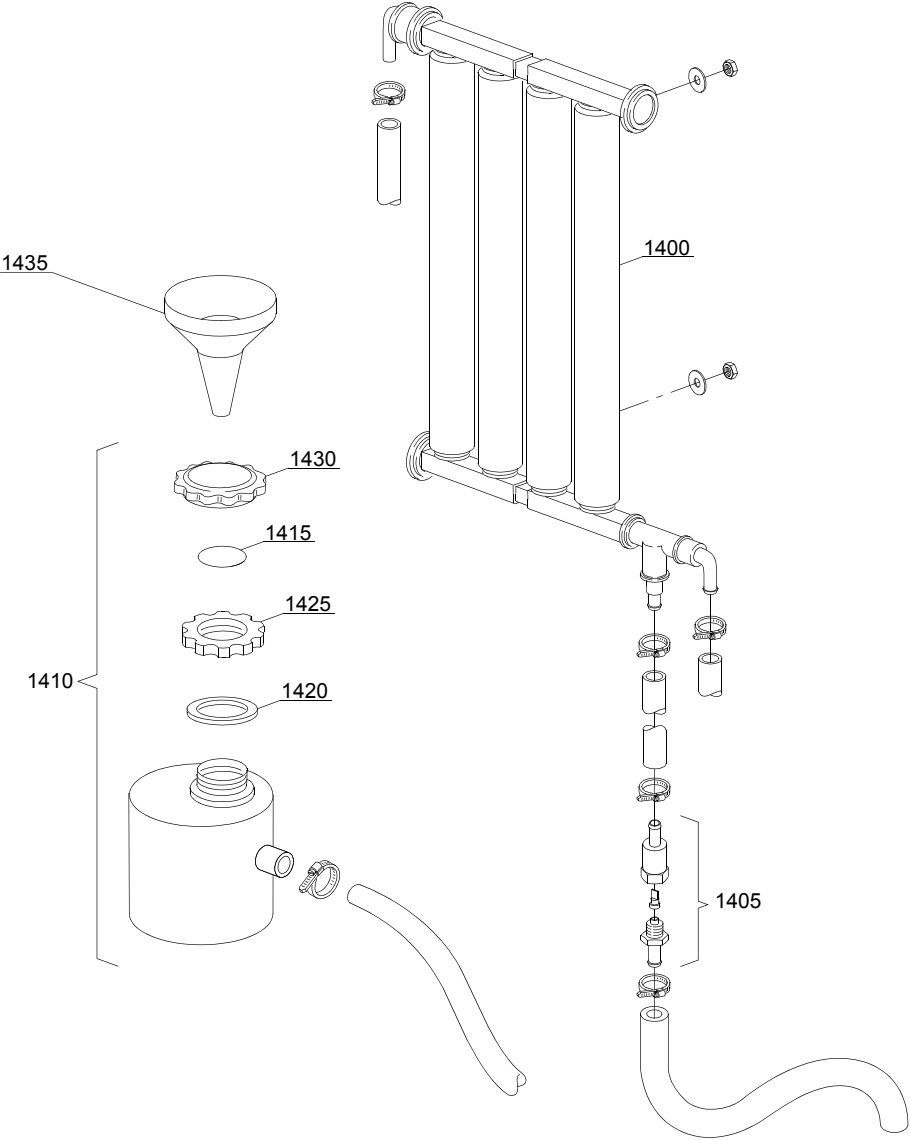

ID	P-code	Model	Type	Accessory	Voltage	Description
MODULE:Water softner group						
1400	16066		9U	ws		4 elements water softner
1405	16070		9U	ws		Nonreturn valve
1410	16065		9U	ws		Salt container
1415	16067/A		9U	ws		OR gasket
1420	16067/B		9U	ws		Gasket
1425	16067/C		9U	ws		Ring nut
1430	16067/D		9U	ws		Plug
1435	16082		9U	ws		Funnel

10_002_e

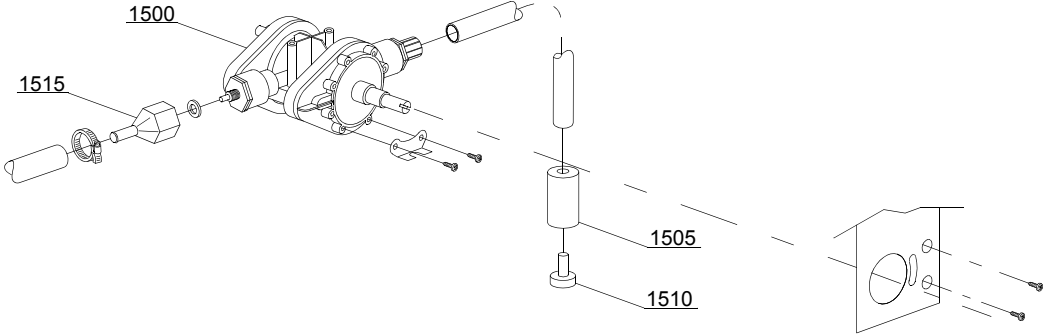

Spare parts

ID	P-code	Model	Type	Accessory	Voltage	Description
MODULE:Shining product dosing device group						
1500	10798		9U			Shining product dosing device
1505	12525		9U			Counter-weight
1510	15058		9U			Small filter
1515	10798/B		9U			Brass pipe fitting

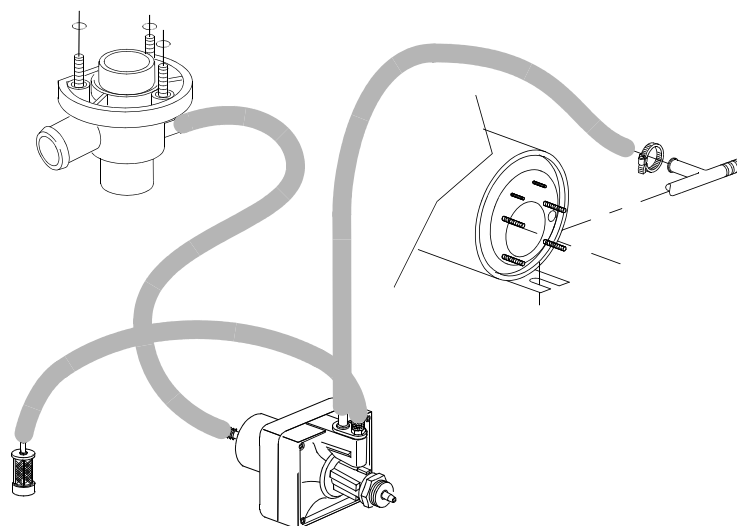
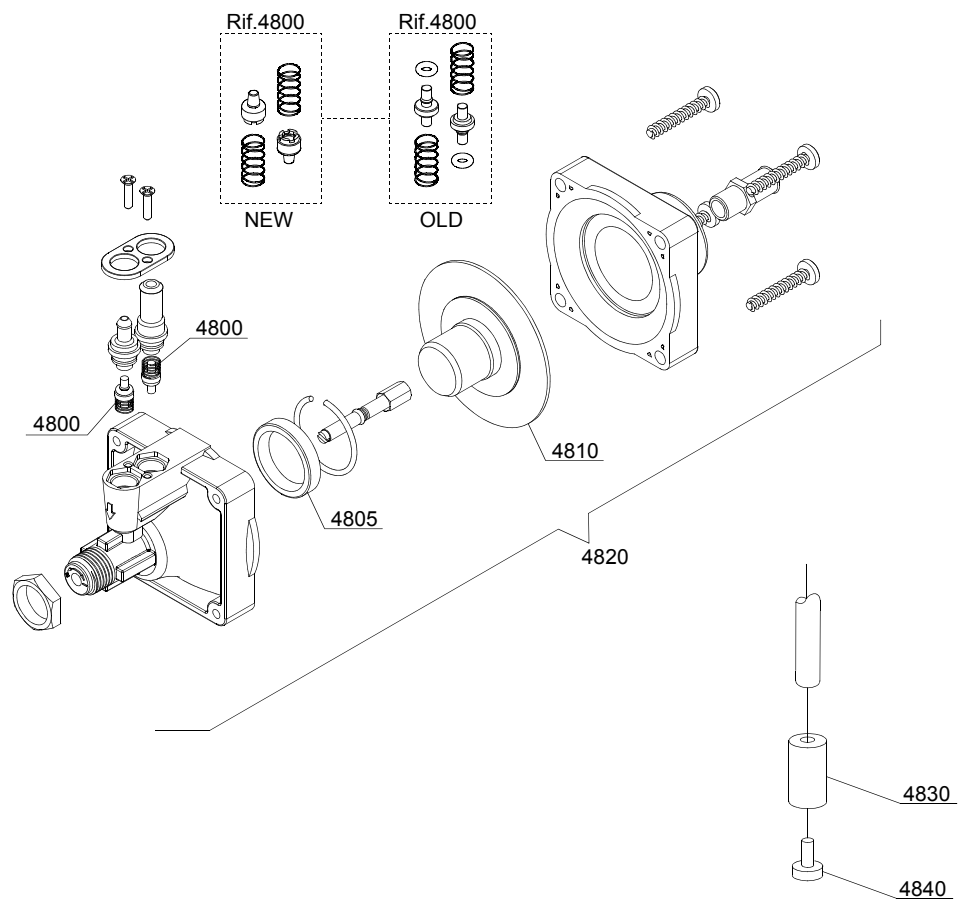

10_004_e

Spare parts

ID	P-code	Model	Type	Accessory	Voltage	Description
MODULE:Shining product dosing device group						
4800	10805		9U			Tecnopro dosing valve
4805	10806		9U			Ø22 gasket
4810	10807		9U			Membrane
4820	10799		9U			Shining product dosing device
4830	12525		9U			Counter-weight
4840	15058		9U			Small filter

11_002_e

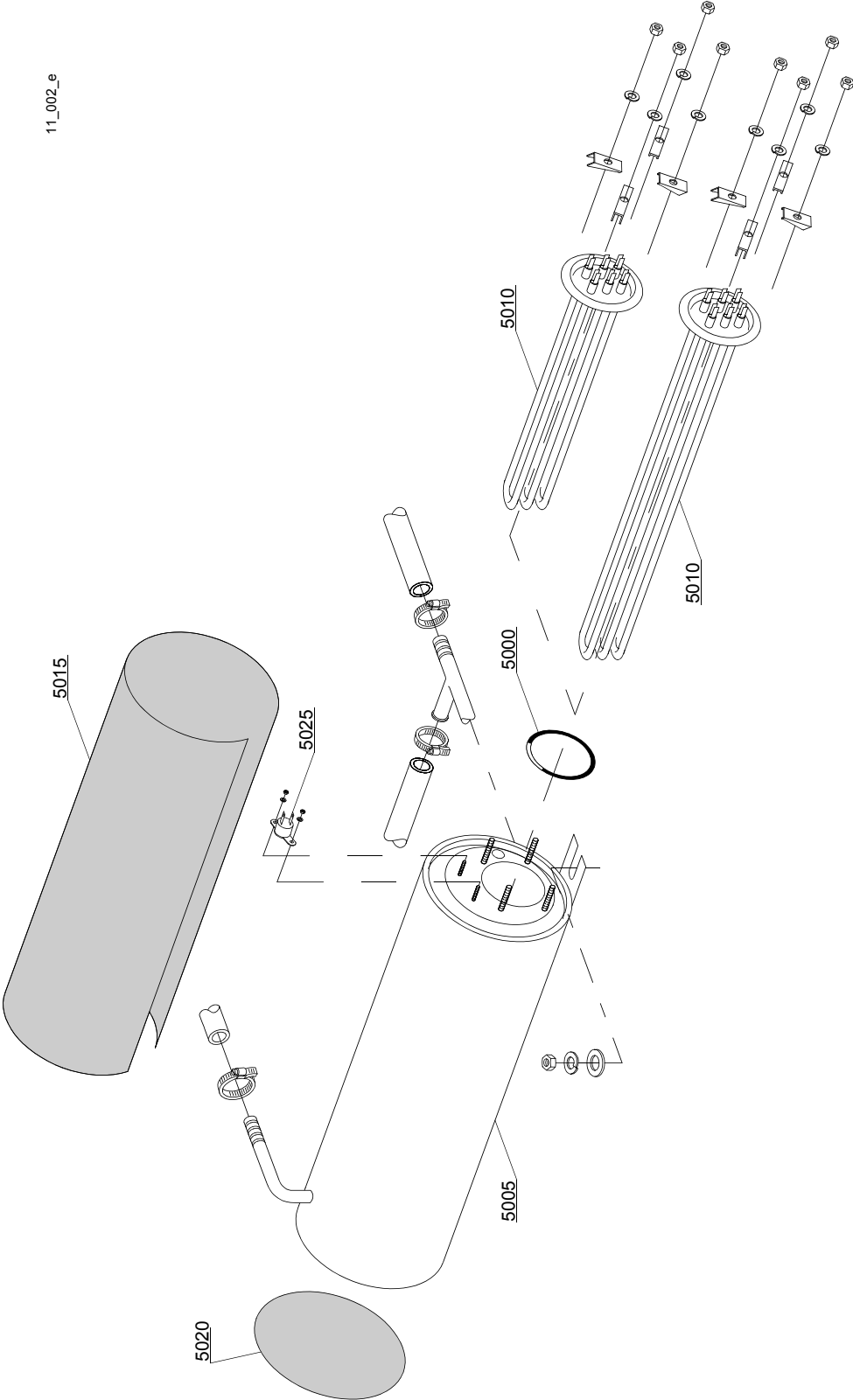

Spare parts

ID	P-code	Model	Type	Accessory	Voltage	Description
MODULE:Boiler group						
5000	13005		9U			OR 151 NBR gasket
5005	150905		9U			Boiler
5010	15089		9U			4,5KW heating element
5010	15089/B		9U			4,5KW - 440V heating element
5010	15089/C		9U			3,5KW - 110V heating element
5010	15089/D		9U			2,5KW - 220V heating element
5010	15089/E		9U			6KW - 230V heating element
5010	15046		9U			3KW heating element
5015	15066		9U			Insulating boiler
5020	15205		9U			Ø160 bottom
5025	15550		9U			Safety thermostat

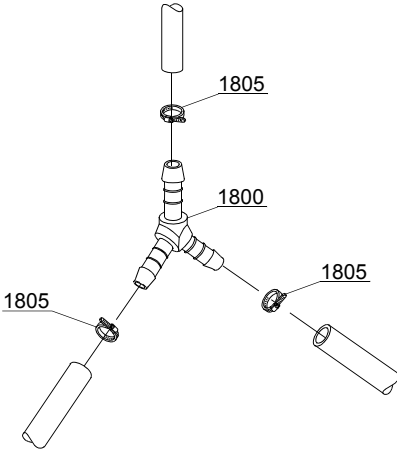

12_003_e

Spare parts

ID	P-code	Model	Type	Accessory	Voltage	Description
MODULE:3 ways derivation						
1800	540091		9U			Ø12 mm plastic 3 ways derivation
1805	11807		9U			12/22 clamp

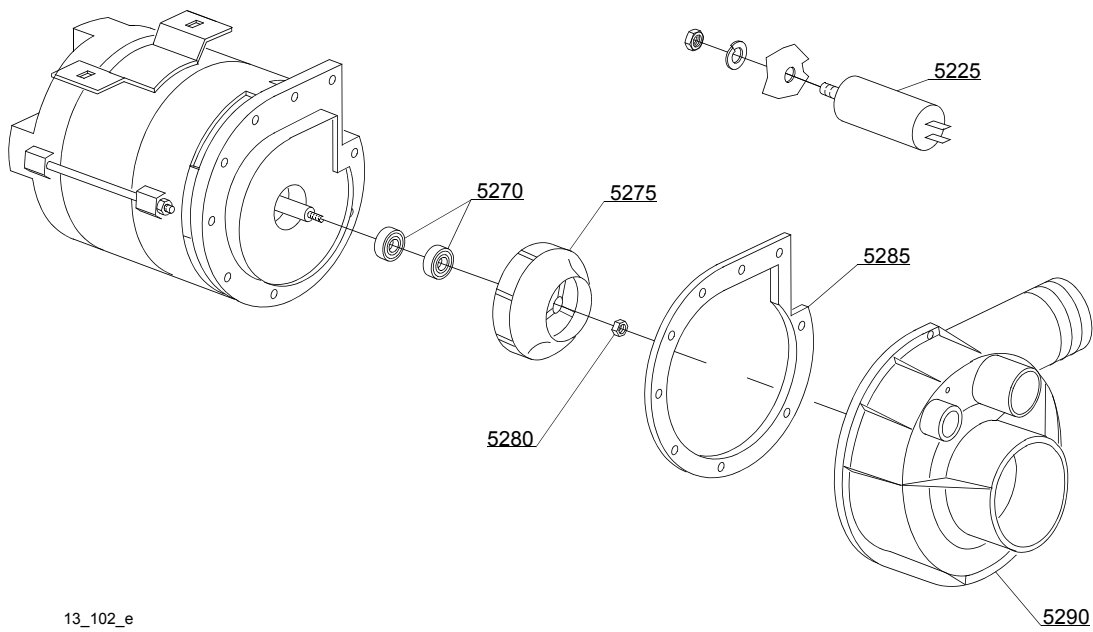
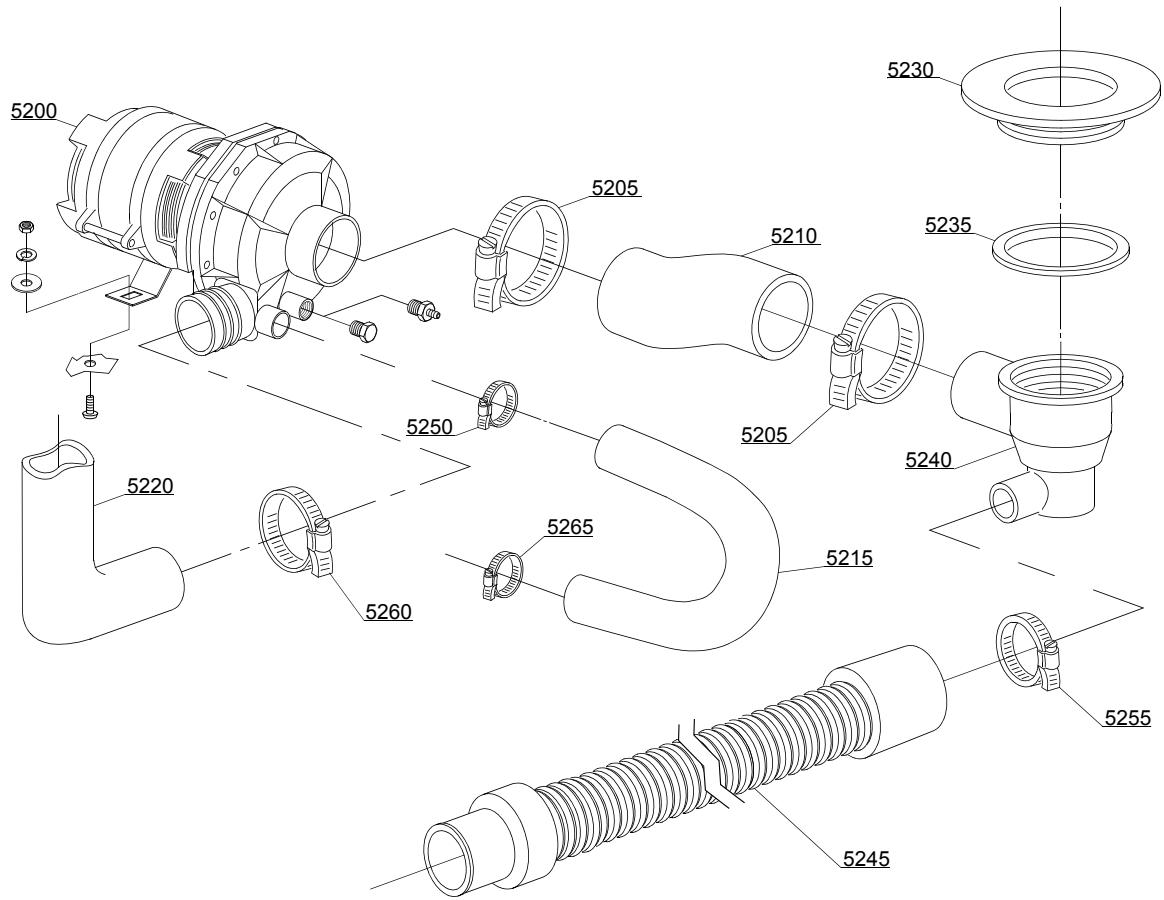

13_102_e

ID	P-code	Model	Type	Accessory	Voltage	Description
MODULE:Wash pump						
5200	15908/P		9U			0,75Hp - 110Vac 60Hz wash pump
5200	15908/O		9U			0,75Hp - 200Vac 50Hz wash pump
5200	15908/D		9U			1Hp - 200Vac 50Hz wash pump
5205	11824		9U			50/70 clamp
5210	25032		9U			Suction pipe coupling
5215	560014		9U			Pump/lower wash turret delivery pipe
5220	560008		9U			Top delivery pipe
5225	15081		9U			12,5 uF condenser
5230	500601		9U			Ring nut
5235	80208		9U			95x75x3 gasket
5240	500606		9U			Right side scrap tray
5245	10727		9U			Drain pipe
5250	11806		9U			25/40 clamp
5255	11807		9U			12/22 clamp
5260	11810		9U			40/60 clamp
5265	11809		9U			30/45 clamp
5270	15080/C		9U			Rotating seals
5275	15079/B		9U			Pump rotor
5280	11724		9U			M6 stainless steel nut
5285	15079/D		9U			Gasket
5290	15031/E		9U			Scroll

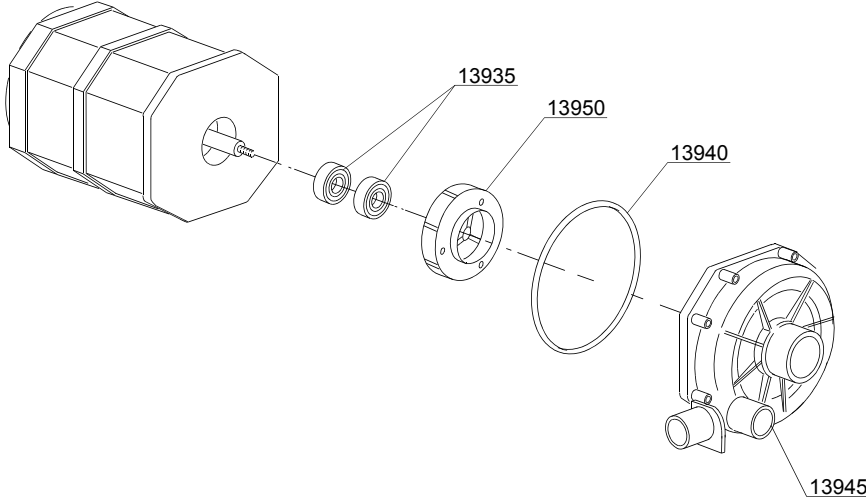
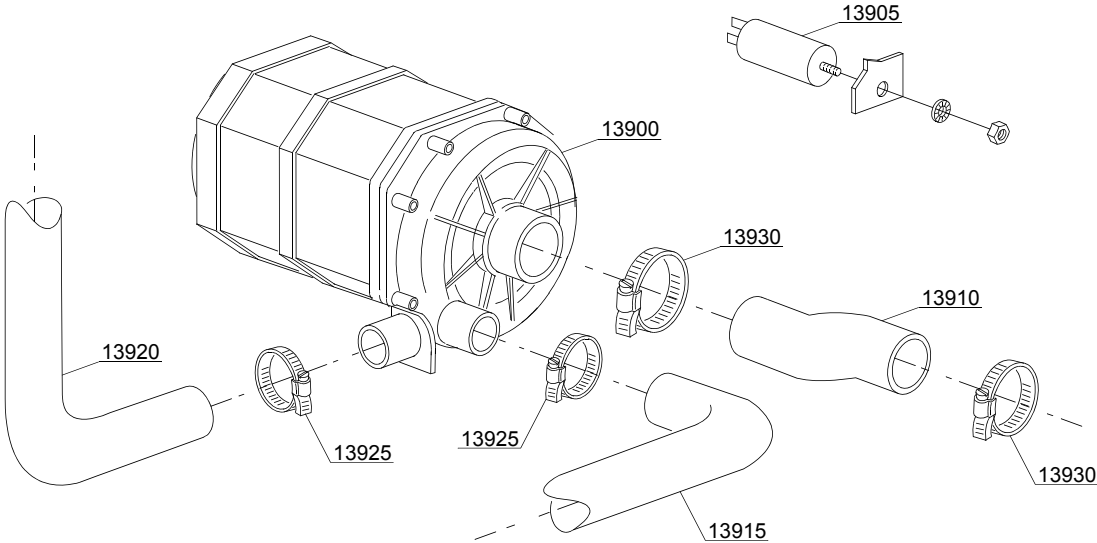

13_110_e

Spare parts

ID	P-code	Model	Type	Accessory	Voltage	Description
MODULE:Wash pump						
13900	150914		9U			0,70Hp wash pump
13900	150915		9U			0,70Hp wash pump - 230Vac 60Hz
13905	15081		9U			12,5 uF condenser
13910	25032/A		9U			Suction pipe coupling
13915	150049		9U			Lower wash pipe coupling
13920	150048/A		9U			Wash ramp
13925	11806		9U			25/40 clamp
13930	11809		9U			30/45 clamp
13935	15080		9U			Rotating seals
13940	7130		9U			OR pump gasket
13945	16182		9U			Scroll
13950	15079/F		9U			Pump rotor

14_002_e

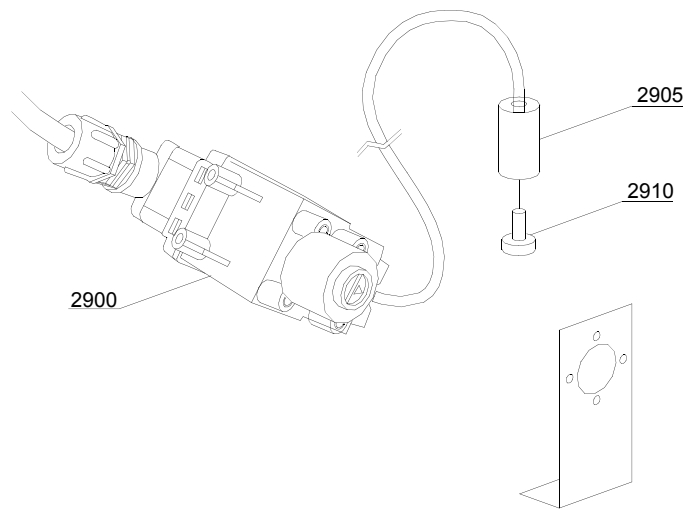
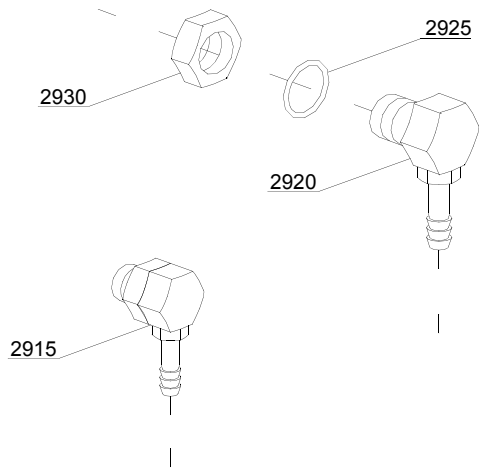

Spare parts

ID	P-code	Model	Type	Accessory	Voltage	Description
MODULE:Dosing device group						
2900	15108/L		9U	dd		Lang dosing device
2905	12525		9U	dd		Counter-weight
2910	15058		9U	dd		Small filter
2915	15123		9U	dd		Compleat plastic injector
2920	15148		9U	dd		Steel injector
2925	15159		9U	dd		OR gasket
2930	10200205		9U	dd		M12x1 stainless steel nut

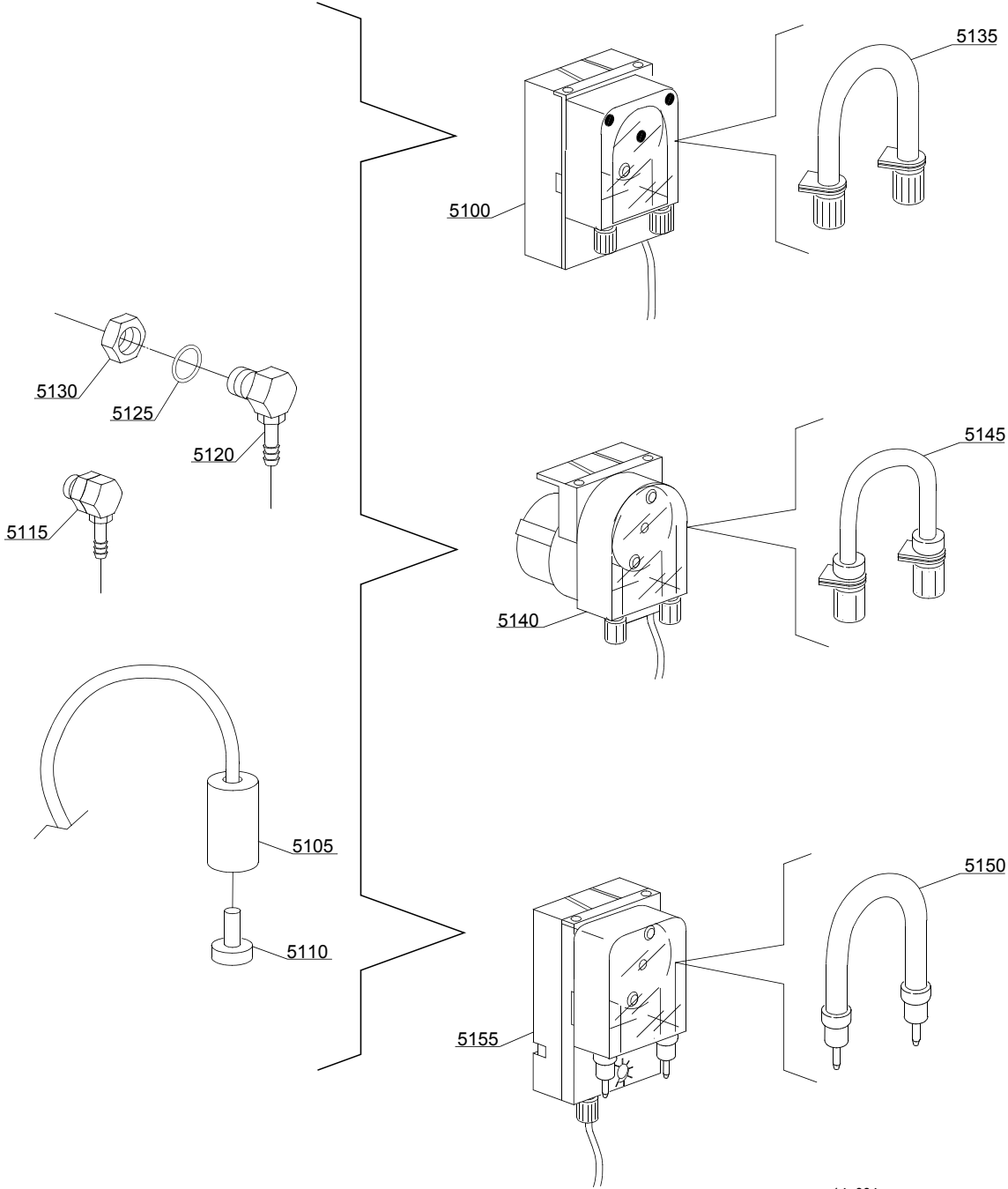

14_004_e

Spare parts

ID	P-code	Model	Type	Accessory	Voltage	Description
MODULE:Dosing device group						
5100	15985		9U	dd		Seko dosing device
5105	12525		9U	dd		Counter-weight
5110	15058		9U	dd		Small filter
5115	15123		9U	dd		Complet plastic injector
5120	15148		9U	dd		Steel injector
5125	15159		9U	dd		OR gasket
5130	10200205		9U	dd		M12x1 stainless steel nut
5135	15185		9U	dd		Ø 10 Seko thermoplastic pipe
5140	15985		9U	dd		Germac dosing device
5145	15108/E		9U	dd		Ø 8 Germac thermoplastic pipe
5150	15985/A		9U	dd		Ø 10 PLAS CONT thermoplastic pipe
5155	15985		9U	dd		PLAS CONT detergent pipe

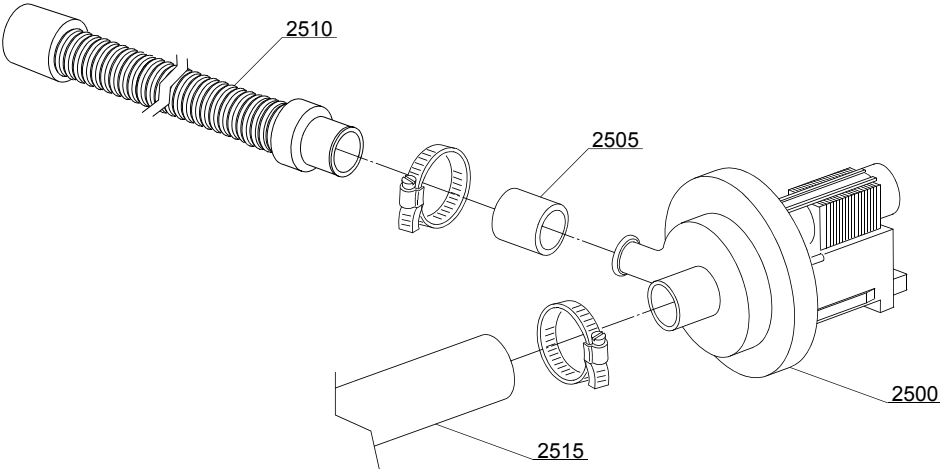

15_004_e

Spare parts

ID	P-code	Model	Type	Accessory	Voltage	Description
MODULE:Drain pump group						
2500	15101		9U	dp		Drain pump
2505	15101/D		9U	dp		Pipe fitting
2510	10727		9U	dp		Drain pipe
2515	18044		9U	dp		Drain coude/pump connection pipe

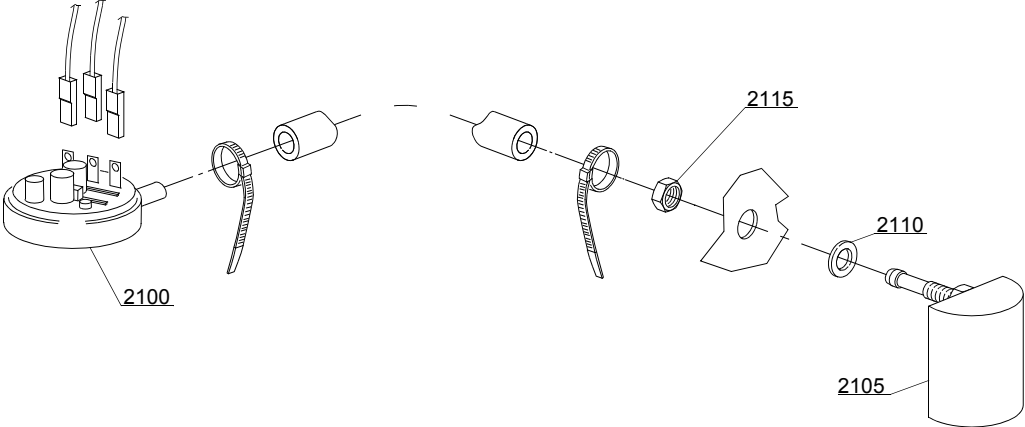

16_001_e

Spare parts

ID	P-code	Model	Type	Accessory	Voltage	Description
MODULE:Pressure switch group with air trap						
2100	10706/A		9U			47-27 pressure switch
2105	10911/B		9U			Air trap assembly
2110	13301		9U			Gasket
2115	11702		9U			M8 stainless steel nut

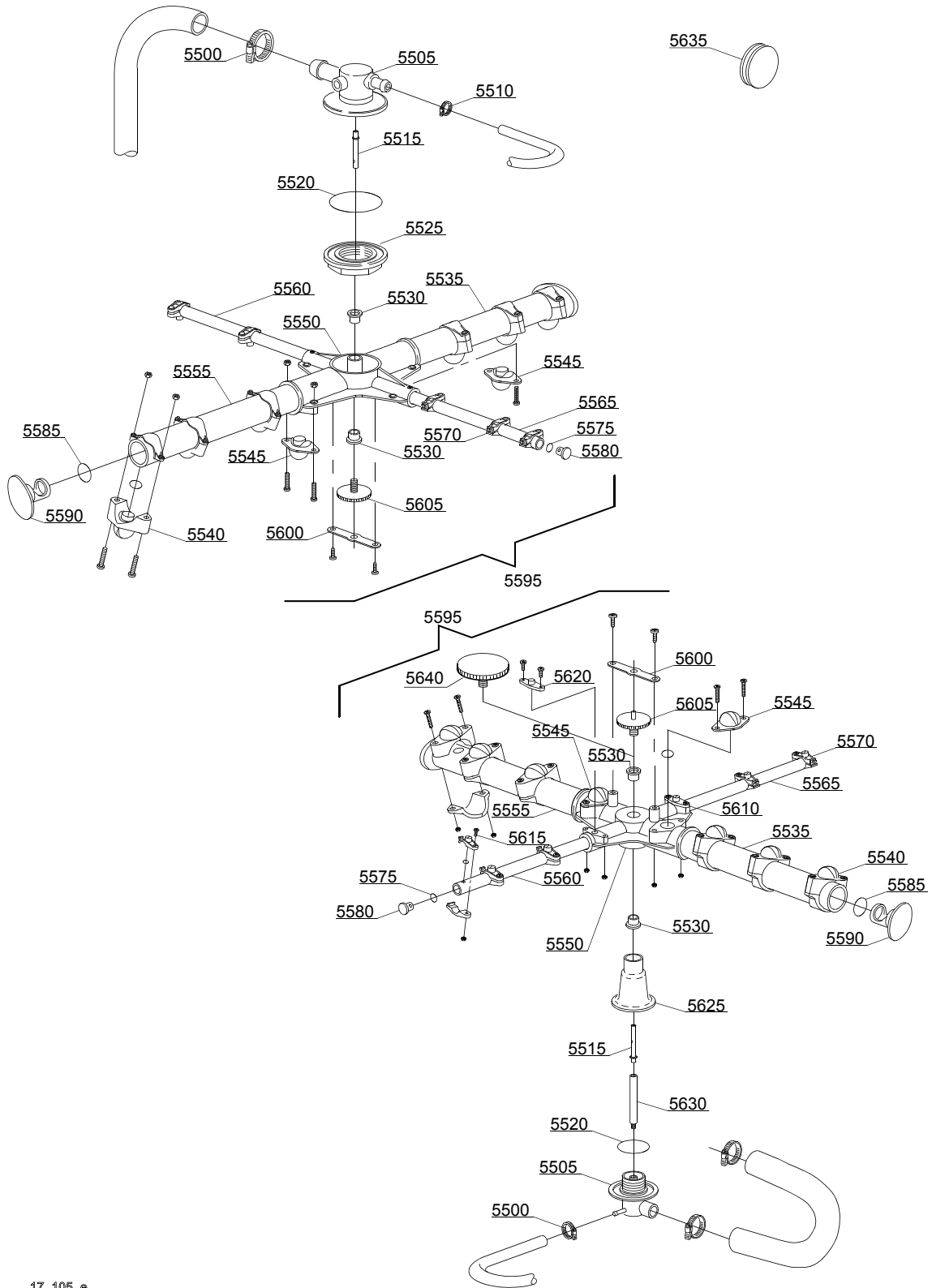

17_105_e

ID	P-code	Model	Type	Accessory	Voltage	Description
MODULE:Turret group with rotating arms						
5500	11806		9U			25/40 clamp
5505	500612		9U			Top/lower turret
5510	11807		9U			12/22 clamp
5515	15300		9U			Ø10x51 lower/top rinse axle
5520	13015		9U			6225 OR 160 NBR gasket
5525	500610		9U			Ring nut for fixing turret
5530	13319		9U			Sliding washer
5535	15571		9U			Ø28 right wash pipe
5540	10211		9U			Ø28 raised nozzle
5545	10218		9U			Ø28 opened plane nozzle
5550	10209		9U			4 ways big rotor
5555	15572		9U			Ø28 left wash pipe
5560	15575		9U			Right rinse pipe
5565	15576		9U			Left rinse pipe
5570	12528		9U			Ø10 complet rinse nozzle
5575	13016		9U			2018 OR 103 NBR gasket
5580	12532		9U			Ø10 plastic plug
5585	13018		9U			OR 2087 NBR gasket
5590	10257		9U			Ø28 plastic plug
5595	15956		9U			Ø28 wash/rinse group
5600	10210		9U			Blocking ring nut rotor plaque
5605	11101/I		9U			Stainless steel group fixing screw
5610	10217		9U			Ø10 closed plane nozzle
5615	11004		9U			4x10 TCB Ø8 spax toothed screw
5620	10213		9U			Ø10 opened plane nozzle
5625	550223		9U			Lower pipe coupling
5630	550226		9U			Lower rinse axle
5635	13316/A		9U			DVGW hole gasket