

DISHWASHER

ELECTROMECHANICAL SWITCHES
LOWER AND UPPER WASHING
INSULATED MODEL

TYPE: 29S

Accessories
BREAK TANK
BOOSTER PUMP
DVGW
COLD RINSE
WATER SOFTNER
DETERGENT DISPENSER
DRAIN PUMP

Spare Parts Manual

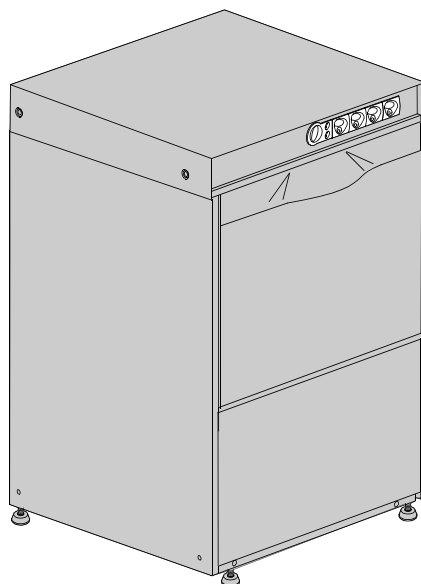

INFORMAZIONI GENERALI

Questo catalogo serve per richiedere con esattezza le parti di ricambio

Nelle ordinazioni indicare:

1) il numero dei codici dei particolari seguito dalla descrizione e la quantità desiderata;

2) Il codice alfa-numerico presente nella seconda colonna della tabella ;

I disegni delle parti di ricambio sono solo indicativi e non rappresentano il pezzo in oggetto.

I dati contenuti in questo catalogo sono indicativi e possono essere soggetti a modifiche senza impegno di preavviso.

ALLGEMEINE INFORMATIONEN

Dieser Ersatzteilkatalog dient zur genauen Angabe der Teile bei Ersatzteilbestellungen.

Bei Ersatzbestellung ist folgendes anzugeben:

1) Die Bestellnummer der Ersatzteile mit der entsprechenden Beschreibung genaue Menge;

2) Der alpha-numerischer Code auf der zweiten Reihe in dein Spclud;

Die Zeichnungen der Ersatzteile sind nur als Hinweise gedacht und stellen nicht das betroffene Teil dar.

Bei den im Katalog angeführten Daten handelt es sich um Anhaltsdaten, die jederzeit, ohne Vorankündigung, geändert werden können.

GENERAL INFORMATION

The present spare parts order exactly the right spare parts

When ordering specify:

1) the part's code number followed by its description and quantity needed;

2) The alpha-numeric code is in the second column in the chart;

Spare parts drawings are general and do not represent the part.

The contents of this catalogue are general and can undergo changes without prior notice.

INFORMACIONES GENERALES

El presente catálogo sirve para pedir con exactitud las partes de repuesto

En los pedidos se debe indicar:

1) el número de código de la parte y a continuación la descripción cantidad deseada;

2) El código alfanumerico presente en la segnada columna de la tabla;

Los diseños de las partes de recambio son solo indicativos y no representan la pieza en cuestión.

Los datos contenidos en el presente catálogo son indicativos y pueden modificarse sin aviso previo.

INFORMATIONS GENERALES

Ce catalogue permet de commander correctement les pièces détachées

Les commandes doivent être passées en indiquant:

1) le numero de code des pièces détachées suivi de leur description quantité désirée;

2) le code alphanumérique dans la deuxième colonne du tableau;

Les plans des pièces détachées sont fournis seulement à titre indicatif et ne représentent pas la pièce concernée.

Les données de ce catalogue sont citées seulement à titre indicatif et peuvent être l'objet de modifications sans avis préalable.

ESEMPIO
EXAMPLE
EXEMPLE
BEISPIEL

Rif.	Codici
MODULE:Particolari	
10505	540903
10510	540908
10515	15065/A
10520	540086
10525	540028

 **Note**

Tutte le informazioni riportate si intendono aggiornate alla data di stampa. Il Produttore si riserva il diritto di apportare qualsiasi modifica richiesta dallo sviluppo evolutivo dei suddetti prodotti.

Per la sicurezza, la garanzia, l'affidabilità ed il valore della lavastoviglie usa solo ricambi originali. **Per alcuni codici, sono richieste quantità minime d'ordine.**

 **Attenzione**

Questo libretto è parte integrante della lavastoviglie e, in caso di passaggio di proprietà, deve essere consegnato al nuovo acquirente.

 **Remarque**

Toutes les informations contenues dans ce manuel s'entendent mises à jour à la date d'impression. En raison du développement constant de ses produits, usine se réserve le droit d'apporter à tout instant les modifications qu'elle jugera utiles.

Pour la sécurité, la garantie, la fiabilité et la valeur de votre lavevaisselles n'utilisez que des pièces de rechange d'origine. **Pour quelque référence on demande un minimum de pièces par commande**

 **Attention**

Ce manuel doit être considéré comme partie intégrante de la la lavevaisselles, en cas de transfert de propriété, doit toujours être remis au nouveau propriétaire.

 **Note**

The information contained herein is valid at the time of going to print. The Company reserves the right to make any changes required by the future development of the above-mentioned products.

For your safety, as well as to preserve the warranty reliability and worth of your dishwashers, use original spare parts only. **For some codes a minimum quantity for order is required.**

 **Warning**

This manual forms an integral part of the dishwashers and - if a transfer of title occurs - must always be handed over to the new owner.

 **Hinweis**

Die Der Hersteller behält sich das Recht vor, jegliche, durch eine Weiterentwicklung der genannten Produkte bedingte Änderungen vornehmen zu können.

Verwenden Sie für Ihre Sicherheit, die Garantie, die Zuverlässigkeit und den Wert Ihrer machine originale Ersatzteile. **Für bestimmte Code nummer werden mindesten bestellungen verlangt.**

 **Achtung**

Diese Betriebsanleitung ist Bestandteile des machine und muss bei seinem Weiterverkauf dem neuen Besitzer ausgehändigt werden.



Code DW 999XXXXXX **CL/Part**

Model DESCRIPTION 

S/N DW A 1015770 Type

400V 3N 50HZ 8A
3500W 500W



16A

IPX3

Pressione Dinamica alimentazione idrica **200-500 kPa**
 Pression dynamique arrivee d'eau
 Dynamic pressure water supply
 Dynamischer Druck asserreinlauf

Pressione dinamica vapore saturo
 Pression dynamique vapeur satuee
 Dymanischer Druck gesattigter Dampf
 Pression Dinamica Vapor Saturado

TECHICAL SPECIFICATION



MADE IN ITALY

Temperatura massima acqua in ingresso **60°C**
 Temperature max eau a l'entre
 Maximale Temperatur Wasseranschluß
 Maximum Water temperature in-feeding

Model 

S/N 

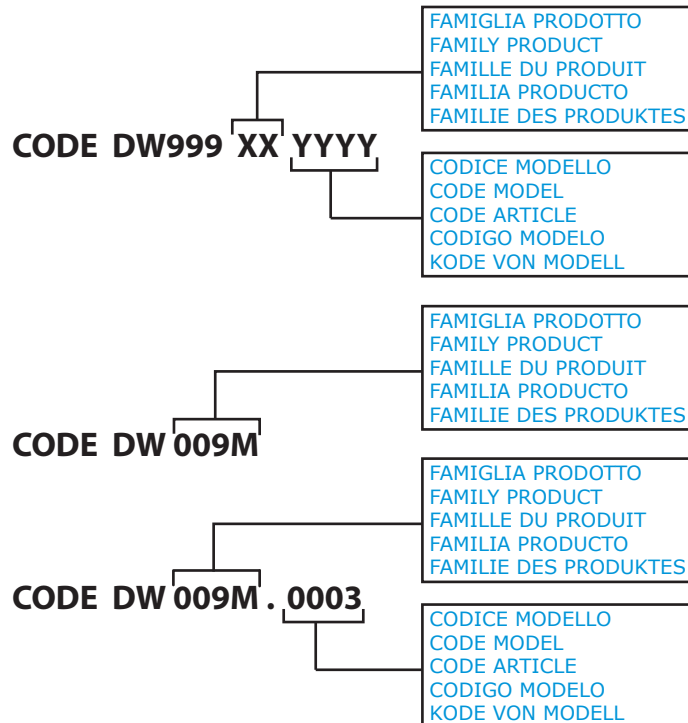

1. Spare parts

General body parts.....	7
Lockup system	9
Control panel and switches.....	11
Electric control components.....	13
Solenoid valve group	15
Solenoid valve group	17
Break Tank	19
Rinse with steady temperature.....	21
Booster pump.....	23
DVGW	25
Water softner group.....	27
Rinse aid dispenser group.....	29
Rinse aid dispenser group.....	31
Boiler group	33
3 ways connection	35
Wash pump	37

Dosing detergent group.....	39
Drain pump group.....	41
Pressure switch group with air trap ...	43
Turret group with rotating arms	45

1.1 Voltage codes

Volt	Voltage code
A	3/N/PE~380-400V 50-60Hz
D	3/PE~200-210V 50-60Hz
F	2/PE~220-240V 50-60Hz
G	3/N/PE~415V 50-60Hz
H	3/PE~220-230V 50-60Hz
K	3/PE~380-400V 50-60Hz
L	3/PE~415V 50-60Hz
M	3/PE~440V 60Hz
P	1/N/PE~220-230V 50-60Hz
R	2/PE~220-240V 50-60Hz
U	1/N/PE~240V 50-60Hz
V	3/PE~240V 50-60Hz
W	1/N/PE~100-110V 50-60Hz

1.2 Product codes

Product code	Full name
Model codes	
e	ELECTRONICAL SWITCHES
uw	LOWER AND UPPER WASHING
i	INSULATED MODEL
Type codes	
29S	29S
Accessory codes	
bt	BREAK TANK
bp	BOOSTER PUMP
dvgw	DVGW
cr	COLD RINSE
ws	WATER SOFTNER
dd	DETERGENT DISPENSER
dp	DRAIN PUMP

01_002_e

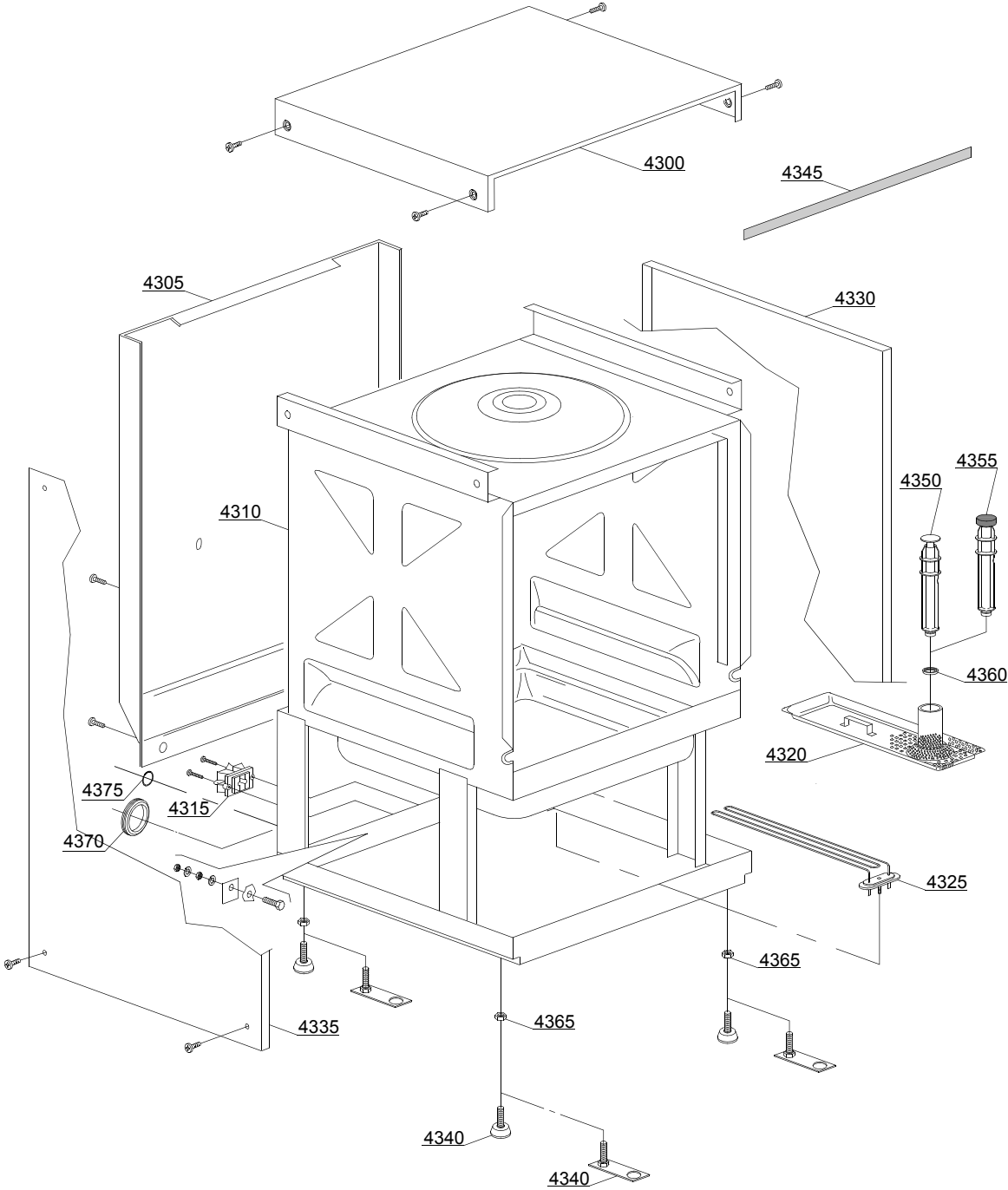

Spare parts

ID	P-code	SN from	SN to	Mod.	Acces.	Volt	Description
Module:General body parts							
4300	560917		-	i			Cover
4305	560919		-	i			Back panel
4305	560938		-	i	bt		Back panel
4310	560900		-	i			Body
4315	15065/A		-	i			Cable-fastener with screw
4320	560925		-	i			Surface filter
4325	150047		-	i			2,7/2,94KW 230/240V heating element
4330	560914		-	i			Right side
4335	560915		-	i			Left side
4340	10786		-	i			M10x25 Ø40 black foot (minimum 4 pieces)
4340	15176		-	i			M10 marina foot
4345	560021		-	i			Profile for door O-ring
4350	500619		-	i			H=213mm Overflow pipe
4355	560020		-	i	dp		Drain pump Overflow pipe
4360	13021		-	i			DEM 40 O-ring (minimum 2 pieces)
4365	11711		-	i			M10 zinc plated nut (minimum 20 pieces)
4370	13317		-	i			D.40mm unloading pipe pass (minimum 2 pieces)
4375	13323		-	i			D.13mm dosing pipe pass (minimum 2 pieces)

em=ELECTROMECHANICAL SWITCHES, uw=LOWER AND UPPER WASHING, i=INSULATED MODEL
29S=29S

bt=BREAK TANK, bp=BOOSTER PUMP, dvgw=DVGW, cr=COLD RINSE, ws=WATER SOFTNER, dd=DETERGENT DISPENSER, dp=DRAIN PUMP

A=3/N/PE~380-400V 50-60Hz, D=3/PE~200-210V 50-60Hz, F=2/PE~220-240V 50-60Hz, G=3/N/PE~415V 50-60Hz, H=3/PE~220-230V 50-60Hz, K=3/PE~380-400V 50-60Hz, L=3/PE~415V 50-60Hz, M=3/PE~440V 60Hz, P=1/N/PE~220-230V 50-60Hz, R=2/PE~220-240V 50-60Hz, U=1/N/PE~240V 50-60Hz, V=3/PE~240V 50-60Hz, W=1/N/PE~100-110V 50-60Hz

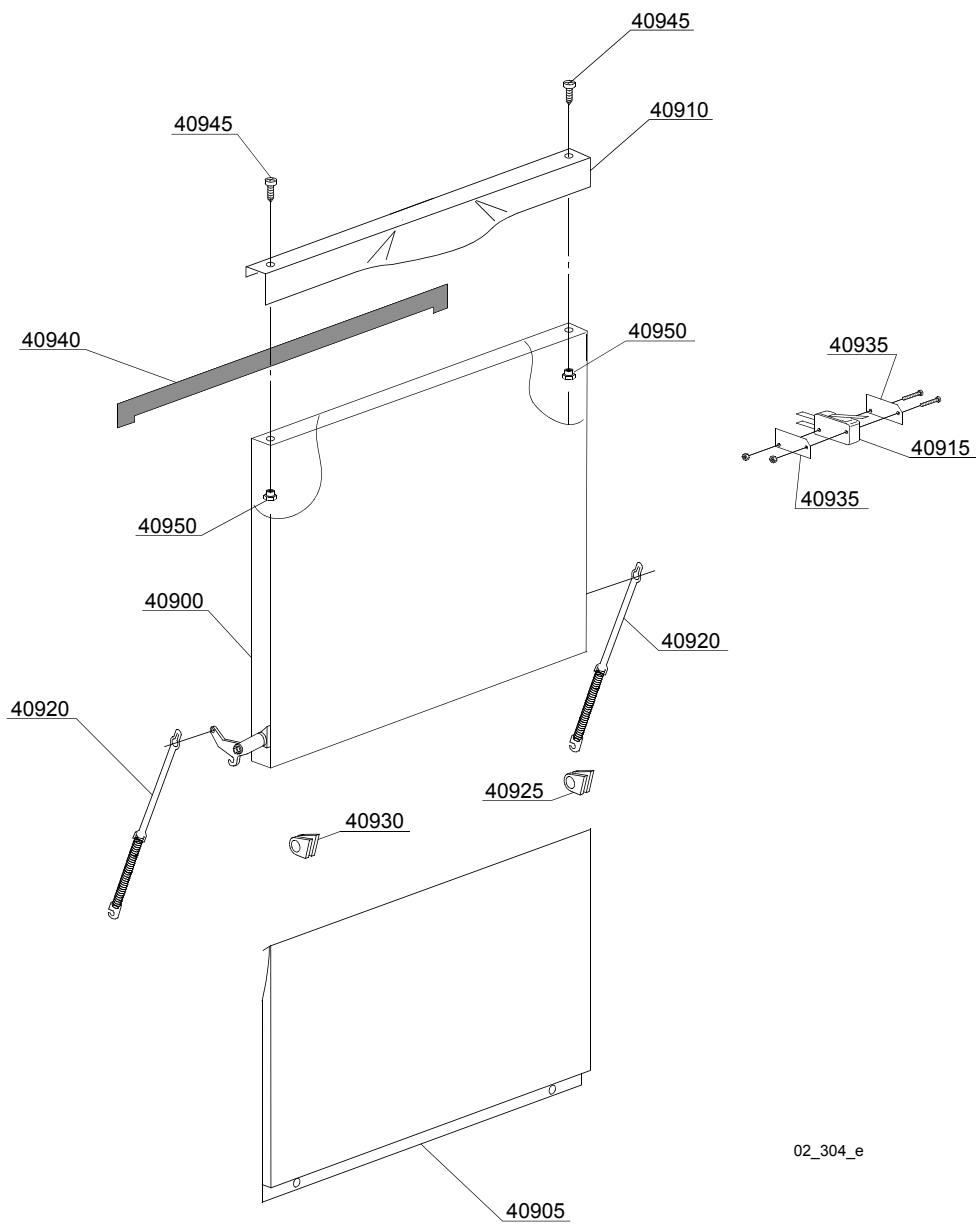

02_304_e

Spare parts

ID	P-code	SN from	SN to	Mod.	Acces.	Volt	Description
Module: Lockup system							
40900	560963		-				Door with steel handle
40905	560920		-				Lower door
40910	560959		-				Stainless steel handle
40915	10704		-				Door microswitch
40920	560003		-				Door spring
40925	560006		-				Right lock for door hinge (minimum 2 pieces)
40930	560007		-				Left lock for door hinge (minimum 2 pieces)
40935	10770		-				Insulation for door microswitch (minimum 3 pieces)
40940	560021		-				Profile for door O-ring
40945	11225		-				M4x6 Inox Screw
40950	11226		-				M4 inox Plated nut

em=ELECTROMECHANICAL SWITCHES, uw=LOWER AND UPPER WASHING, i=INSULATED MODEL

29S=29S

bt=BREAK TANK, bp=BOOSTER PUMP, dvgw=DVGW, cr=COLD RINSE, ws=WATER SOFTNER, dd=DETERGENT DISPENSER, dp=DRAIN PUMP

A=3/N/PE~380-400V 50-60Hz, D=3/PE~200-210V 50-60Hz, F=2/PE~220-240V 50-60Hz, G=3/N/PE~415V 50-60Hz, H=3/PE~220-230V 50-60Hz, K=3/PE~380-400V 50-60Hz, L=3/PE~415V 50-60Hz, M=3/PE~440V 60Hz, P=1/N/PE~220-230V 50-60Hz, R=2/PE~220-240V 50-60Hz, U=1/N/PE~240V 50-60Hz, V=3/PE~240V 50-60Hz, W=1/N/PE~100-110V 50-60Hz

03_055_e

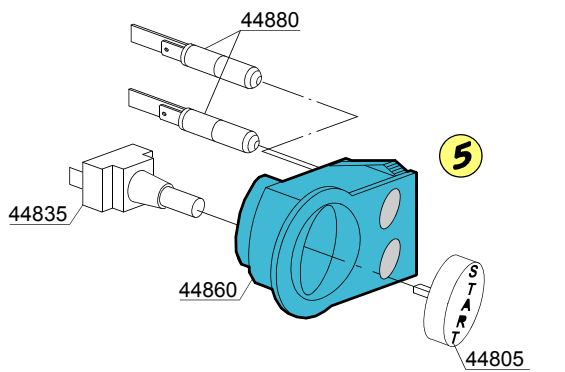
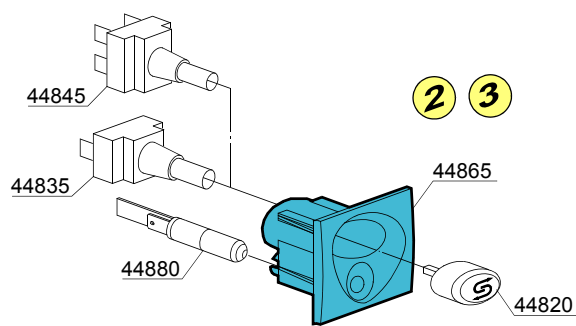
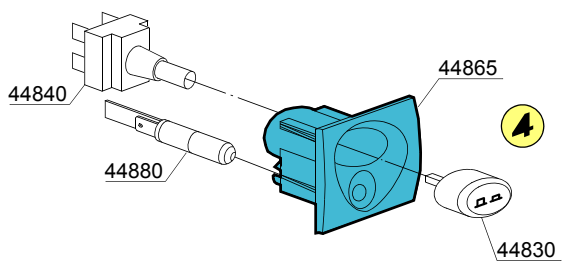
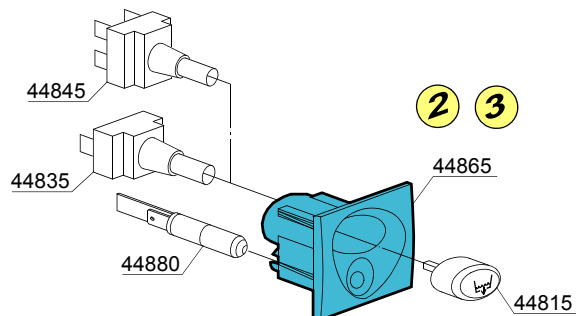
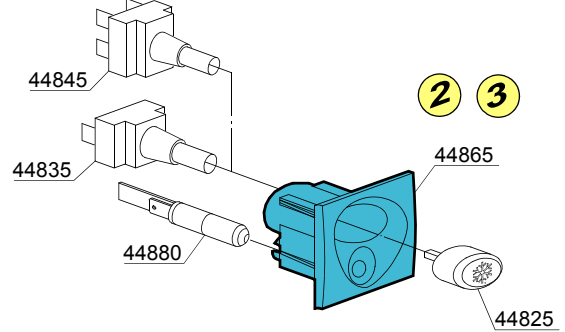
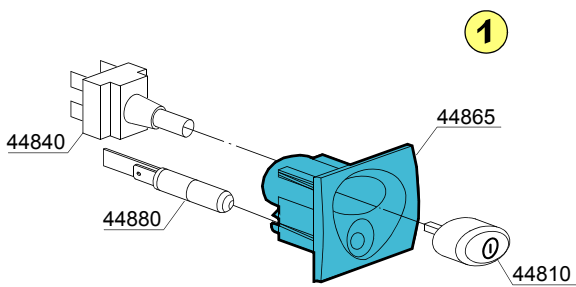
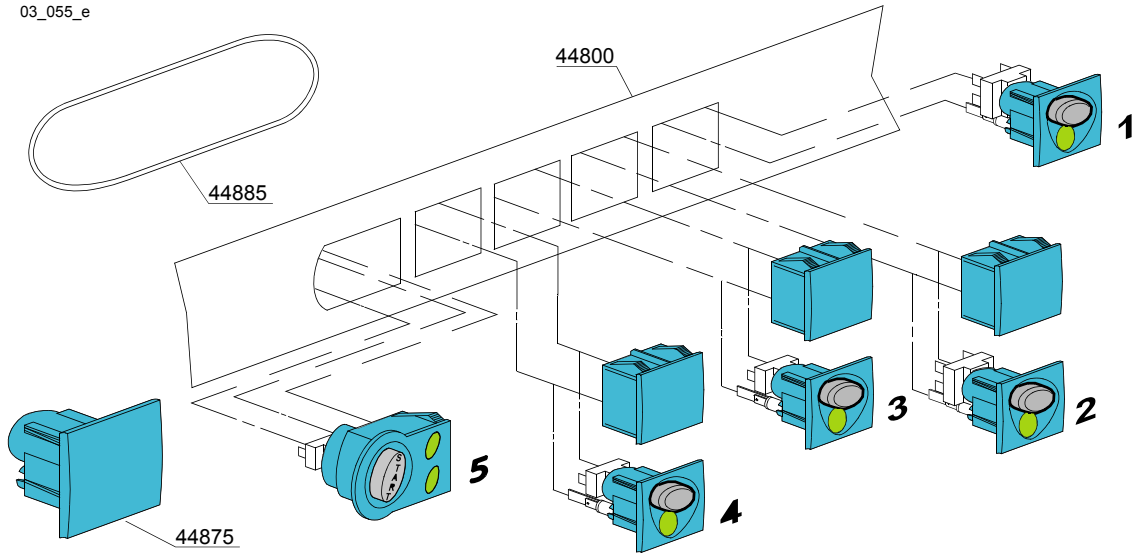

Spare parts

ID	P-code	SN from	SN to	Mod.	Acces.	Volt	Description
Module:Control panel and switches							
44800	510009		-	em			Control panel
44805	89347		-	em			Start push button
44810	89340		-	em			ON-OFF push button
44815	89343		-	em	dp		Drain pump push button
44820	89345		-	em	ws		Regeneration push button
44825	89344		-	em	cr		Hot/cold push button
44830	89342		-	em			Time selector switch push button
44835	15813		-	em			16A unipolar switch
44840	15812		-	em			16A switch
44845	15800		-	em			16A bipolar switch
44860	89301		-	em			Start push button support
44865	89304		-	em			Push button support
44870	89302		-	em	dp,ws,cr		Push button support
44875	89303		-	em			Closed support
44880	15826		-	em			Pilot light 220V
44885	89333		-	em			OR O-ring (minimum 3 pieces)

em=ELECTROMECHANICAL SWITCHES, uw=LOWER AND UPPER WASHING, i=INSULATED MODEL
29S=29S

bt=BREAK TANK, bp=BOOSTER PUMP, dvgw=DVGW, cr=COLD RINSE, ws=WATER SOFTNER, dd=DETERGENT DISPENSER, dp=DRAIN PUMP

A=3/N/PE~380-400V 50-60Hz, D=3/PE~200-210V 50-60Hz, F=2/PE~220-240V 50-60Hz, G=3/N/PE~415V 50-60Hz, H=3/PE~220-230V 50-60Hz, K=3/PE~380-400V 50-60Hz, L=3/PE~415V 50-60Hz, M=3/PE~440V 60Hz, P=1/N/PE~220-230V 50-60Hz, R=2/PE~220-240V 50-60Hz, U=1/N/PE~240V 50-60Hz, V=3/PE~240V 50-60Hz, W=1/N/PE~100-110V 50-60Hz

04_003_e

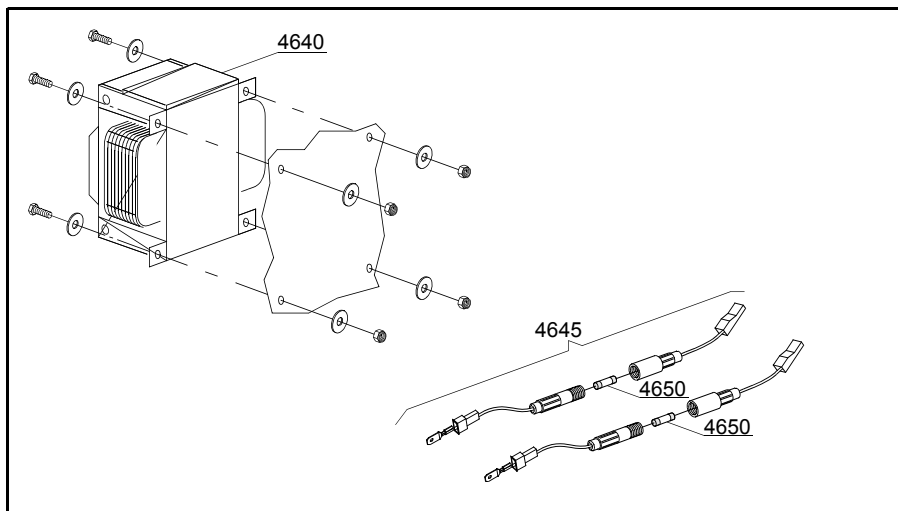
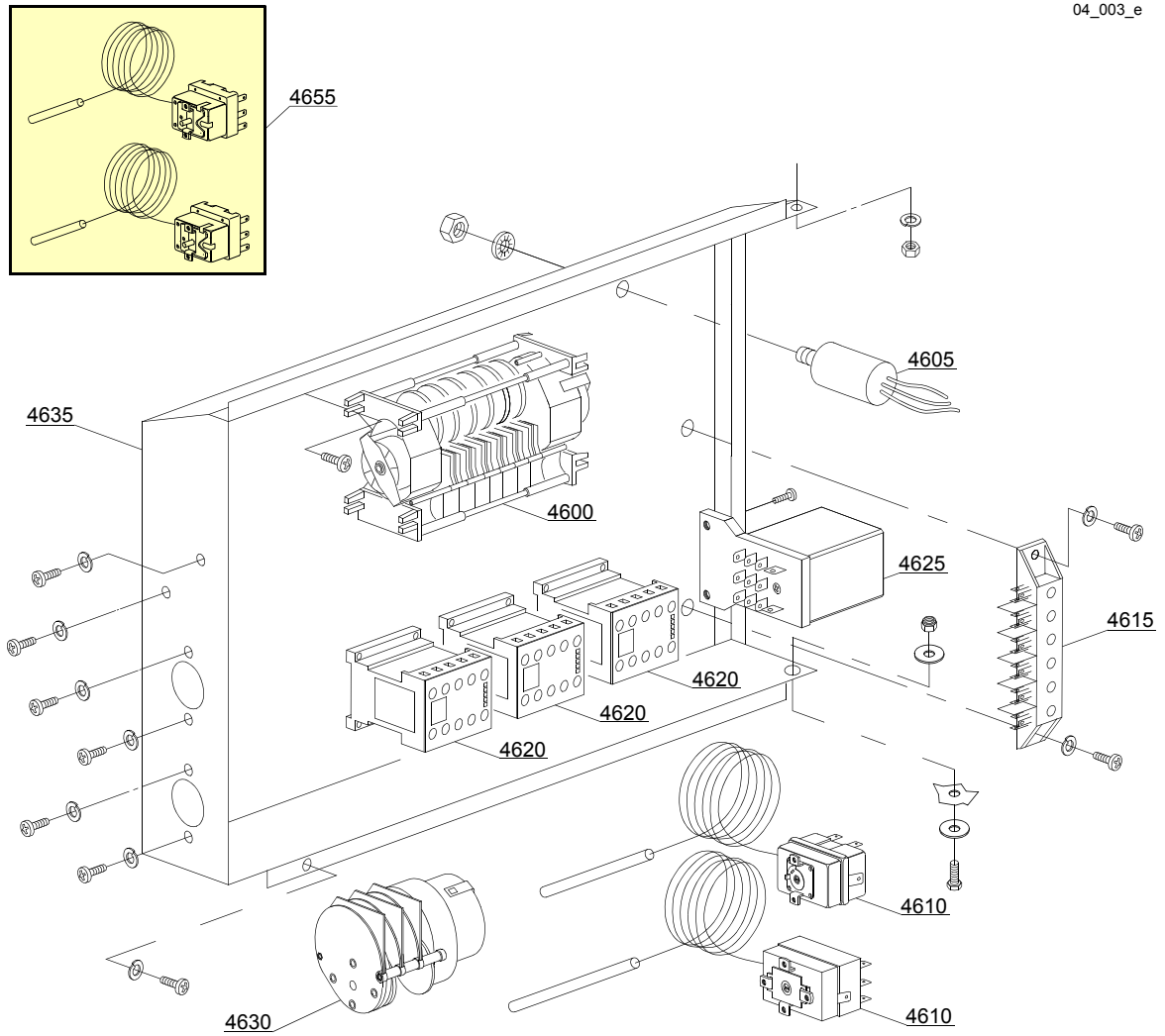

Spare parts

ID	P-code	SN from	SN to	Mod.	Acces.	Volt	Description
Module:Electric control components							
4600	10300123		-	i		A	90/180" timer - 230Vac 50Hz
4600	30001028		-	i			120/180" timer - 230Vac 60Hz
4600	22011/A		-	i		A	120/240" timer - 200Vac 50Hz
4600	30001031		-	i		A	120/180" timer with thermostop - 230Vac 50Hz
4600	30001032		-	i			120/180" - 230V 60Hz timer with thermostop
4600	30001030		-	i			120/240" timer with thermostop - 230Vac 50Hz
4605	15146		-	i			Low noise filter
4605	15149		-	i			Low noise filter
4605	15187		-	i			Low noise filter
4610	10707/1		-	i			0-90°C thermostat
4615	500551		-	i			6 poles terminal board
4620	15086		-	i			Contactora 230V 50/60Hz 4C
4620	15086/B		-	i			Contactora 240V 50Hz
4620	15086/T		-	i			200Vac3N 50/60HZ contactora
4625	16037/D		-	i	ws		16A bipolar relay - 230Vac
4625	15620		-	i	ws		16A bipolar relay in deviation
4630	16064/A		-	i	ws		Regeneration timer
4635	560921		-	i			Electric components panel
4640	15381		-	i			160Va transformer 0-230-400-415-440/230V
4645	15147		-	i			Fuse-holder
4650	15163		-	i			Fuse (minimum 5 pieces)
4651	50553		-	i			3 times electronic timer with regeneration

em=ELECTROMECHANICAL SWITCHES, uw=LOWER AND UPPER WASHING, i=INSULATED MODEL
29S=29S

bt=BREAK TANK, bp=BOOSTER PUMP, dvgw=DVGW, cr=COLD RINSE, ws=WATER SOFTNER, dd=DETERGENT DISPENSER, dp=DRAIN PUMP

A=3/N/PE~380-400V 50-60Hz, D=3/PE~200-210V 50-60Hz, F=2/PE~220-240V 50-60Hz, G=3/N/PE~415V 50-60Hz, H=3/PE~220-230V 50-60Hz, K=3/PE~380-400V 50-60Hz, L=3/PE~415V 50-60Hz, M=3/PE~440V 60Hz, P=1/N/PE~220-230V 50-60Hz, R=2/PE~220-240V 50-60Hz, U=1/N/PE~240V 50-60Hz, V=3/PE~240V 50-60Hz, W=1/N/PE~100-110V 50-60Hz

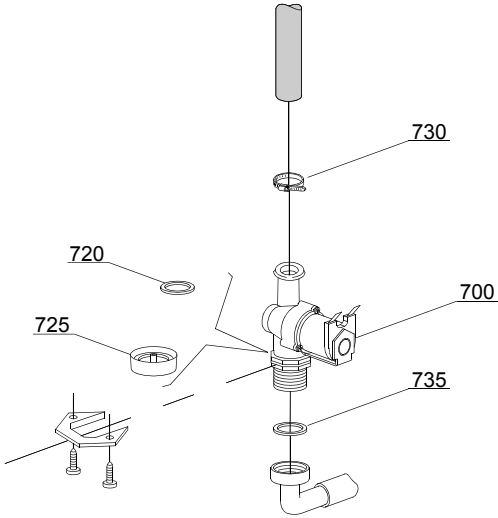

05_002_e

Spare parts

ID	P-code	SN from	SN to	Mod.	Acces.	Volt	Description
Module:Solenoid valve group							
700	10703		-	i,em			Single solenoid valve - 230Vac
720	N.C.		-	i,em			Pression reducing valve
730	11807		-	i,em			12/22 clamp (minimum 3 pieces)
735	13307		-	i,em			3/4 gasket

em=ELECTROMECHANICAL SWITCHES, uw=LOWER AND UPPER WASHING, i=INSULATED MODEL
29S=29S

bt=BREAK TANK, bp=BOOSTER PUMP, dvgw=DVGW, cr=COLD RINSE, ws=WATER SOFTNER, dd=DETERGENT DISPENSER, dp=DRAIN PUMP

A=3/N/PE~380-400V 50-60Hz, D=3/PE~200-210V 50-60Hz, F=2/PE~220-240V 50-60Hz, G=3/N/PE~415V 50-60Hz, H=3/PE~220-230V 50-60Hz, K=3/PE~380-400V 50-60Hz, L=3/PE~415V 50-60Hz, M=3/PE~440V 60Hz, P=1/N/PE~220-230V 50-60Hz, R=2/PE~220-240V 50-60Hz, U=1/N/PE~240V 50-60Hz, V=3/PE~240V 50-60Hz, W=1/N/PE~100-110V 50-60Hz

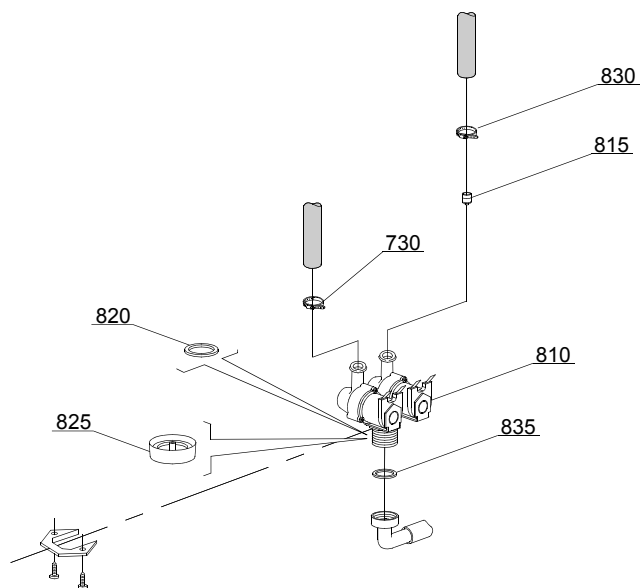

05_003_ε

Spare parts

ID	P-code	SN from	SN to	Mod.	Acces.	Volt	Description
Module:Solenoid valve group							
810	15098		-	i,em	cr,ws		Double solenoid valve - Ø10 - 230Vac
815	15115		-	i,em	cr,ws		Green pression solenoid valve for regeneration (minimum 2 pieces)
820	N.C.		-	i,em	cr,ws		Pression reducing valve
830	11807		-	i,em			12/22 clamp (minimum 3 pieces)
835	13307		-	i,em			3/4 gasket

em=ELECTROMECHANICAL SWITCHES, uw=LOWER AND UPPER WASHING, i=INSULATED MODEL
29S=29S

bt=BREAK TANK, bp=BOOSTER PUMP, dvgw=DVGW, cr=COLD RINSE, ws=WATER SOFTNER, dd=DETERGENT DISPENSER, dp=DRAIN PUMP

A=3/N/PE~380-400V 50-60Hz, D=3/PE~200-210V 50-60Hz, F=2/PE~220-240V 50-60Hz, G=3/N/PE~415V 50-60Hz, H=3/PE~220-230V 50-60Hz, K=3/PE~380-400V 50-60Hz, L=3/PE~415V 50-60Hz, M=3/PE~440V 60Hz, P=1/N/PE~220-230V 50-60Hz, R=2/PE~220-240V 50-60Hz, U=1/N/PE~240V 50-60Hz, V=3/PE~240V 50-60Hz, W=1/N/PE~100-110V 50-60Hz

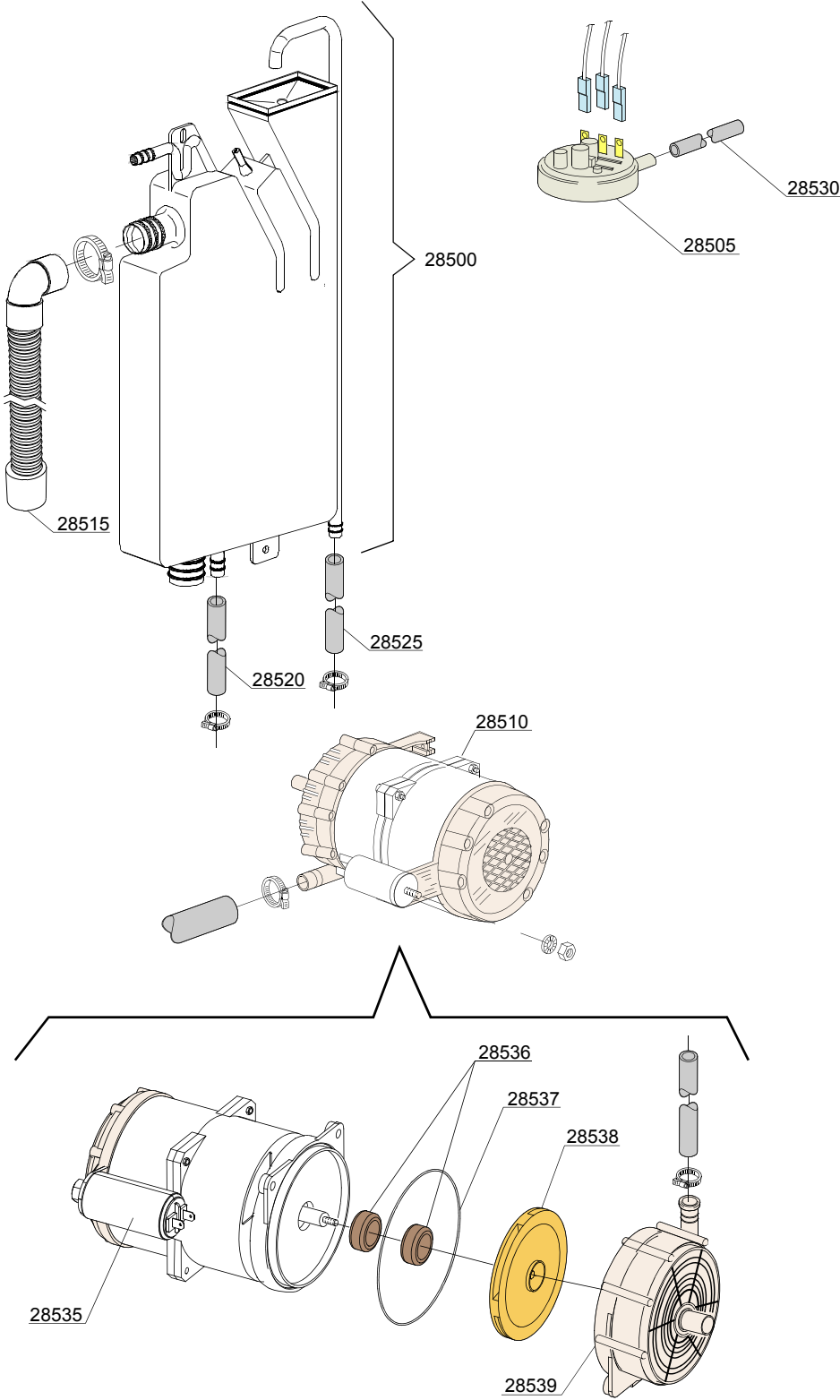

06_004ae

Spare parts

ID	P-code	SN from	SN to	Mod.	Acces.	Volt	Description
Module:Break Tank							
28500	15735		-	i,em	bt		Break tank assembly
28505	10706/A		-	i,em	bt		47-27 pressure switch
28510	15100/DO		-	i,em	bt		Booster pump 220/240V - body pumps in plastic
28515	15721		-	i,em	bt		BT long pipe L=1070
28515	15722		-	i,em	bt		BT middle pipe L=920
28515	15723		-	i,em	bt		BT small pipe L=690
28520	2907350		-	i,em	bt		12x20 EPDM rubber hose
28525	2907352		-	i,em	bt		PVC WRAS rubber hose
28530	14508		-	i,em	bt		4,5x9 EPDM rubber hose (minimum 2 mt)
28535	10702		-	i,em	bt		5 uF condenser - 450V
28536	15100/S		-	i,em	bt		Rotating seals
28537	15100/T		-	i,em	bt		OR-(O-ring) gasket EPDM
28538	15100/U		-	i,em	bt		Pump rotor
28539	15100/V		-	i,em	bt		Scroll

em=ELECTROMECHANICAL SWITCHES, uw=LOWER AND UPPER WASHING, i=INSULATED MODEL
29S=29S

bt=BREAK TANK, bp=BOOSTER PUMP, dvgw=DVGW, cr=COLD RINSE, ws=WATER SOFTNER, dd=DETERGENT DISPENSER, dp=DRAIN PUMP

A=3/N/PE~380-400V 50-60Hz, D=3/PE~200-210V 50-60Hz, F=2/PE~220-240V 50-60Hz, G=3/N/PE~415V 50-60Hz, H=3/PE~220-230V 50-60Hz, K=3/PE~380-400V 50-60Hz, L=3/PE~415V 50-60Hz, M=3/PE~440V 60Hz, P=1/N/PE~220-230V 50-60Hz, R=2/PE~220-240V 50-60Hz, U=1/N/PE~240V 50-60Hz, V=3/PE~240V 50-60Hz, W=1/N/PE~100-110V 50-60Hz

06_006_e

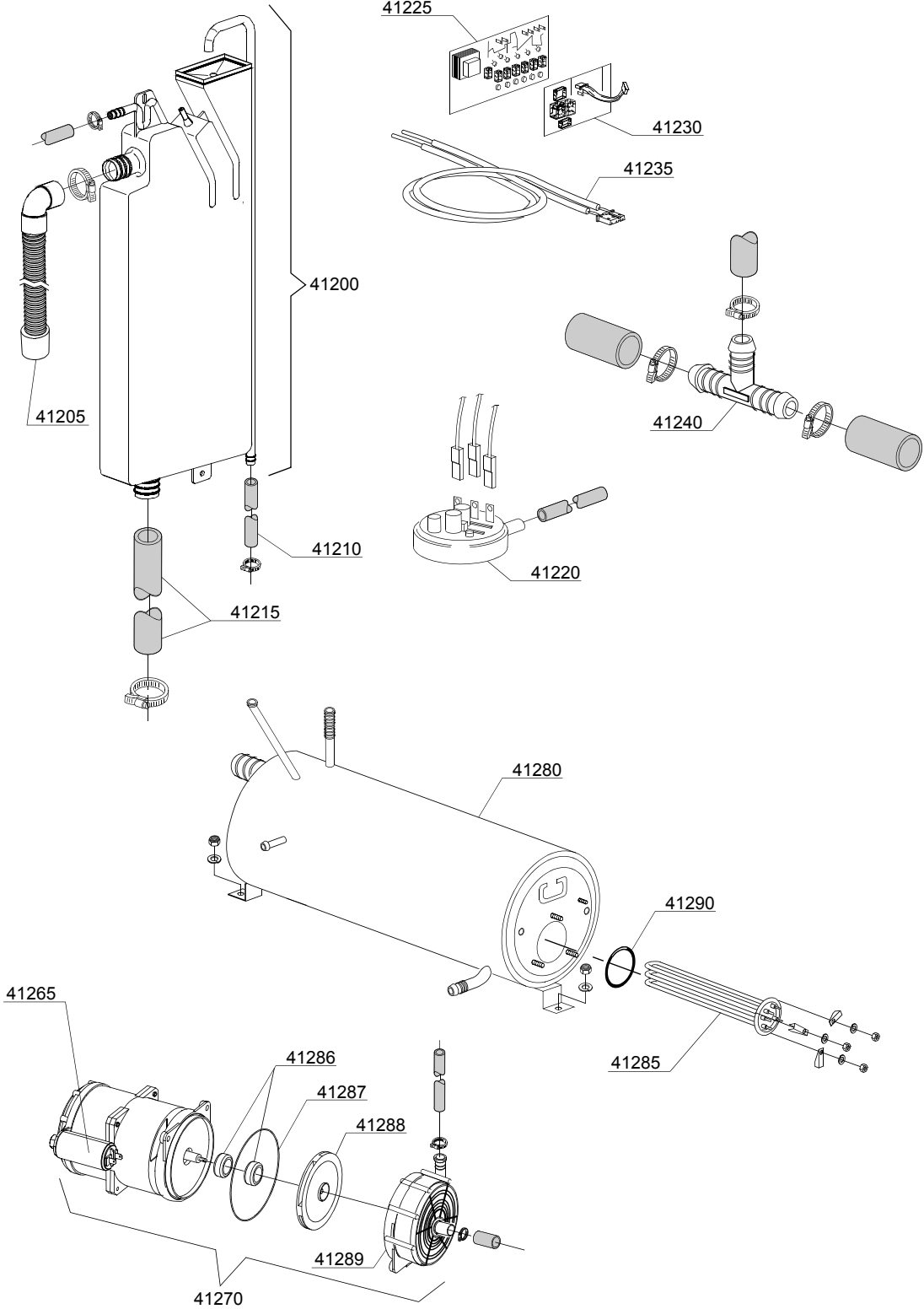

Spare parts

ID	P-code	SN from	SN to	Mod.	Acces.	Volt	Description
Module: Rinse with steady temperature							
41200	15720		-	i,em			Break tank assembly
41205	15721		-	i,em			BT middle pipe L=920
41210	2907352		-	i,em			PVC WRAS rubber hose
41215	x		-	i,em			Pipe coupling
41220	10706/A		-	i,em			34-100 pressure switch
41225	50569		-	i,em			Electronic Card without Chip
41230	50559		-	i,em			Circuit board DP
41235	50562		-	i,em			Sensor
41240	540098		-	i,em			3 ways D25
41265	10702		-	i,em			5 uF condenser
41270	15100/DO		-	i,em			Rinsing pump
41275	10718		-	i,em			Pump pipe coupling
41280	560062		-	i,em			Boiler
41285	15089		-	i,em			Boiler Element 4,5KW 230 / 240 VaC 3
41285	15089/B		-	i,em			Boiler Element 4,5KW 240 /440 V
41285	15089/E		-	i,em			Boiler Element 6KW 230 / 240 VaC 3
41286	15100/S		-	i,em			Rotating seals
41287	15100/T		-	i,em			OR (O-ring) gasket EPDM
41288	15100/U		-	i,em			Pump rotor
41289	15100/V		-	i,em			Scroll
41290	13015		-	i,em			OR (O-ring) 6225 gasket 160 NBR

em=ELECTROMECHANICAL SWITCHES, uw=LOWER AND UPPER WASHING, i=INSULATED MODEL
29S=29S

bt=BREAK TANK, bp=BOOSTER PUMP, dvgw=DVGW, cr=COLD RINSE, ws=WATER SOFTNER, dd=DETERGENT DISPENSER, dp=DRAIN PUMP

A=3/N/PE~380-400V 50-60Hz, D=3/PE~200-210V 50-60Hz, F=2/PE~220-240V 50-60Hz, G=3/N/PE~415V 50-60Hz, H=3/PE~220-230V 50-60Hz, K=3/PE~380-400V 50-60Hz, L=3/PE~415V 50-60Hz, M=3/PE~440V 60Hz, P=1/N/PE~220-230V 50-60Hz, R=2/PE~220-240V 50-60Hz, U=1/N/PE~240V 50-60Hz, V=3/PE~240V 50-60Hz, W=1/N/PE~100-110V 50-60Hz

07_003_e

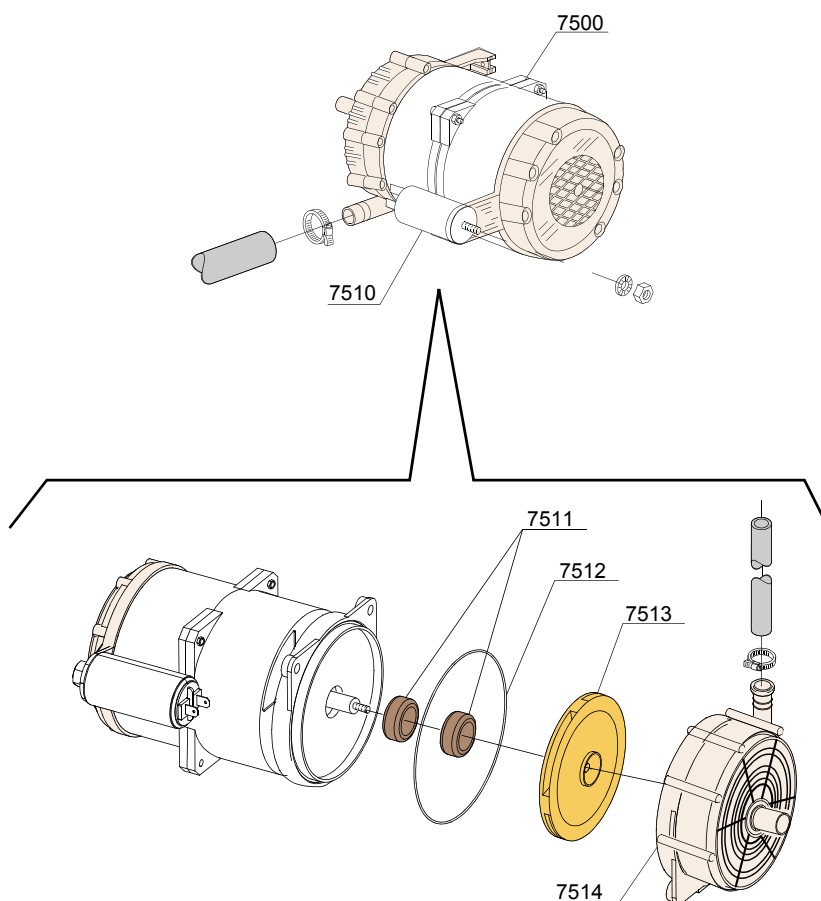

VERSIONE BREAK TANK / VERSIONE PLUS
BREAK TANK VERSION / SYSTEM PLUS VERSION
VERSION BREAK TANK / VERSION SISTEME PLUS

Spare parts

ID	P-code	SN from	SN to	Mod.	Acces.	Volt	Description
Module:Booster pump							
7500	15100/DO		-	i,em	bp		Booster pump 220/240V - body pumps in plastic
7505	12013		-	i,em	bp		Rubber-holder
7510	10702		-	i,em	bp		5 uF condenser - 450V
7511	15100/S			i,em	bp		Rotating seals
7512	15100/T			i,em	bp		OR (O-ring) gasket EPDM
7513	15100/U			i,em	bp		Pump rotor
7514	15100/V			i,em	bp		Scroll

em=ELECTROMECHANICAL SWITCHES, uw=LOWER AND UPPER WASHING, i=INSULATED MODEL
29S=29S

bt=BREAK TANK, bp=BOOSTER PUMP, dvgw=DVGW, cr=COLD RINSE, ws=WATER SOFTNER, dd=DETERGENT DISPENSER, dp=DRAIN PUMP

A=3/N/PE~380-400V 50-60Hz, D=3/PE~200-210V 50-60Hz, F=2/PE~220-240V 50-60Hz, G=3/N/PE~415V 50-60Hz, H=3/PE~220-230V 50-60Hz, K=3/PE~380-400V 50-60Hz, L=3/PE~415V 50-60Hz, M=3/PE~440V 60Hz, P=1/N/PE~220-230V 50-60Hz, R=2/PE~220-240V 50-60Hz, U=1/N/PE~240V 50-60Hz, V=3/PE~240V 50-60Hz, W=1/N/PE~100-110V 50-60Hz

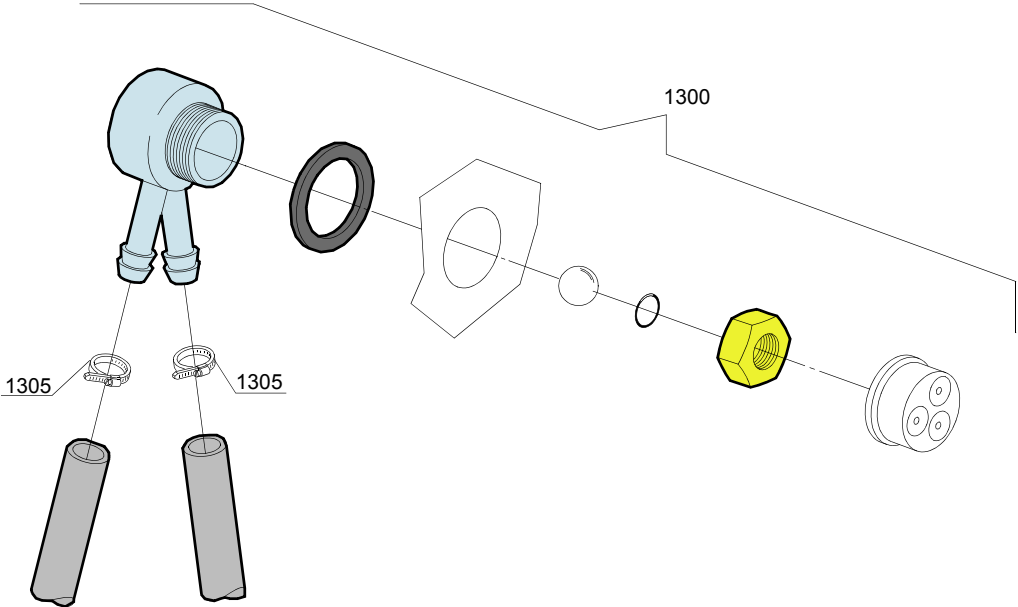

08_005_e

Spare parts

ID	P-code	SN from	SN to	Mod.	Acces.	Volt	Description
Module:DVGW							
1300	99900006		-	i,em	dvgw		DVGW assembly
1305	11807		-	i,em	dvgw		12/22 clamp (minimum 3 pieces)

em=ELECTROMECHANICAL SWITCHES, uw=LOWER AND UPPER WASHING, i=INSULATED MODEL
29S=29S

bt=BREAK TANK, bp=BOOSTER PUMP, dvgw=DVGW, cr=COLD RINSE, ws=WATER SOFTNER, dd=DETERGENT DISPENSER, dp=DRAIN PUMP

A=3/N/PE~380-400V 50-60Hz, D=3/PE~200-210V 50-60Hz, F=2/PE~220-240V 50-60Hz, G=3/N/PE~415V 50-60Hz, H=3/PE~220-230V 50-60Hz, K=3/PE~380-400V 50-60Hz, L=3/PE~415V 50-60Hz, M=3/PE~440V 60Hz, P=1/N/PE~220-230V 50-60Hz, R=2/PE~220-240V 50-60Hz, U=1/N/PE~240V 50-60Hz, V=3/PE~240V 50-60Hz, W=1/N/PE~100-110V 50-60Hz

09_001_e

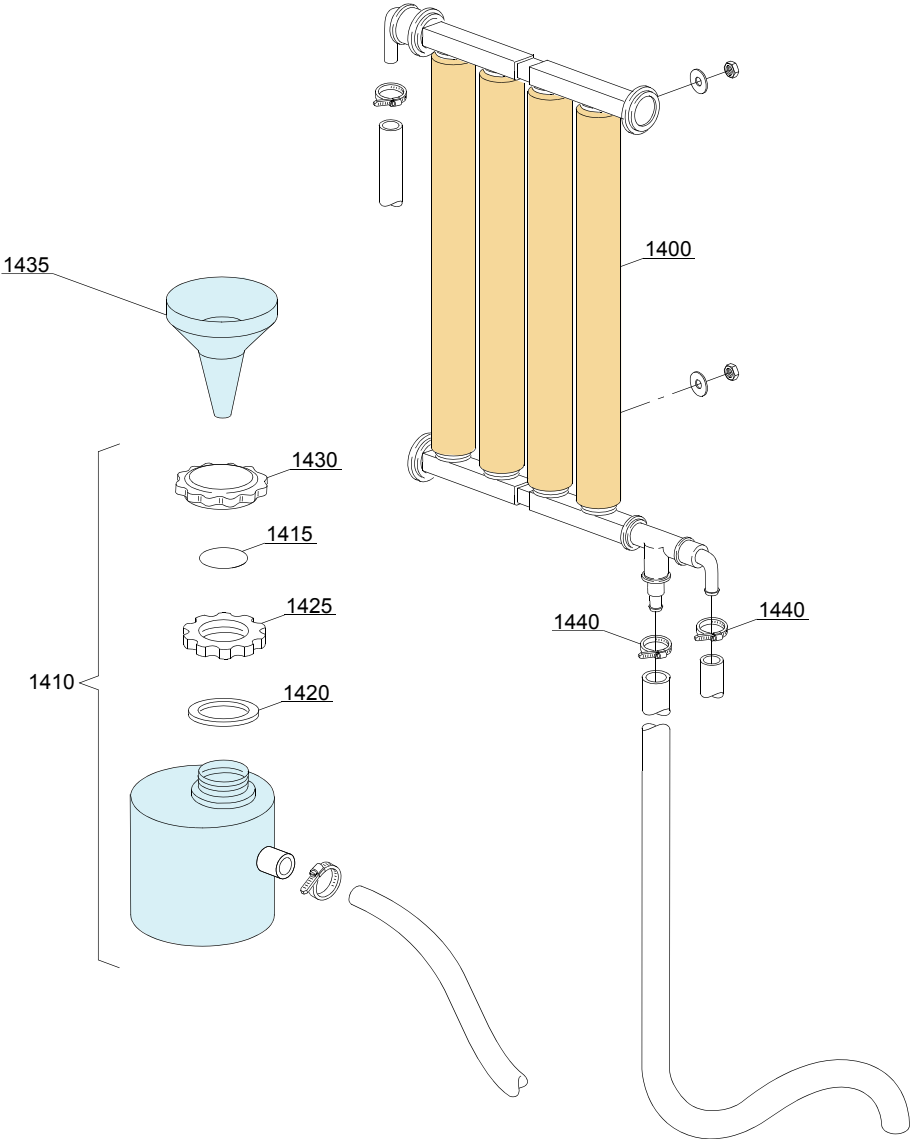

Spare parts

ID	P-code	SN from	SN to	Mod.	Acces.	Volt	Description
Module: Water softner group							
1400	16066		-	em	ws		4 elements water softner
1405	16070		-	em	ws		Nonreturn valve
1410	16065		-	em	ws		Salt container
1415	16067/A		-	em	ws		OR O-ring
1420	16067/B		-	em	ws		O-ring
1425	16067/C		-	em	ws		Ring nut
1430	16067/D		-	em	ws		Plug
1435	16082		-	em	ws		Funnel
1440	11807		-	em	ws		12/22 clamp (minimum 3 pieces)

em=ELECTROMECHANICAL SWITCHES, uw=LOWER AND UPPER WASHING, i=INSULATED MODEL
29S=29S

bt=BREAK TANK, bp=BOOSTER PUMP, dvgw=DVGW, cr=COLD RINSE, ws=WATER SOFTNER, dd=DETERGENT DISPENSER, dp=DRAIN PUMP

A=3/N/PE~380-400V 50-60Hz, D=3/PE~200-210V 50-60Hz, F=2/PE~220-240V 50-60Hz, G=3/N/PE~415V 50-60Hz, H=3/PE~220-230V 50-60Hz, K=3/PE~380-400V 50-60Hz, L=3/PE~415V 50-60Hz, M=3/PE~440V 60Hz, P=1/N/PE~220-230V 50-60Hz, R=2/PE~220-240V 50-60Hz, U=1/N/PE~240V 50-60Hz, V=3/PE~240V 50-60Hz, W=1/N/PE~100-110V 50-60Hz

10_001be

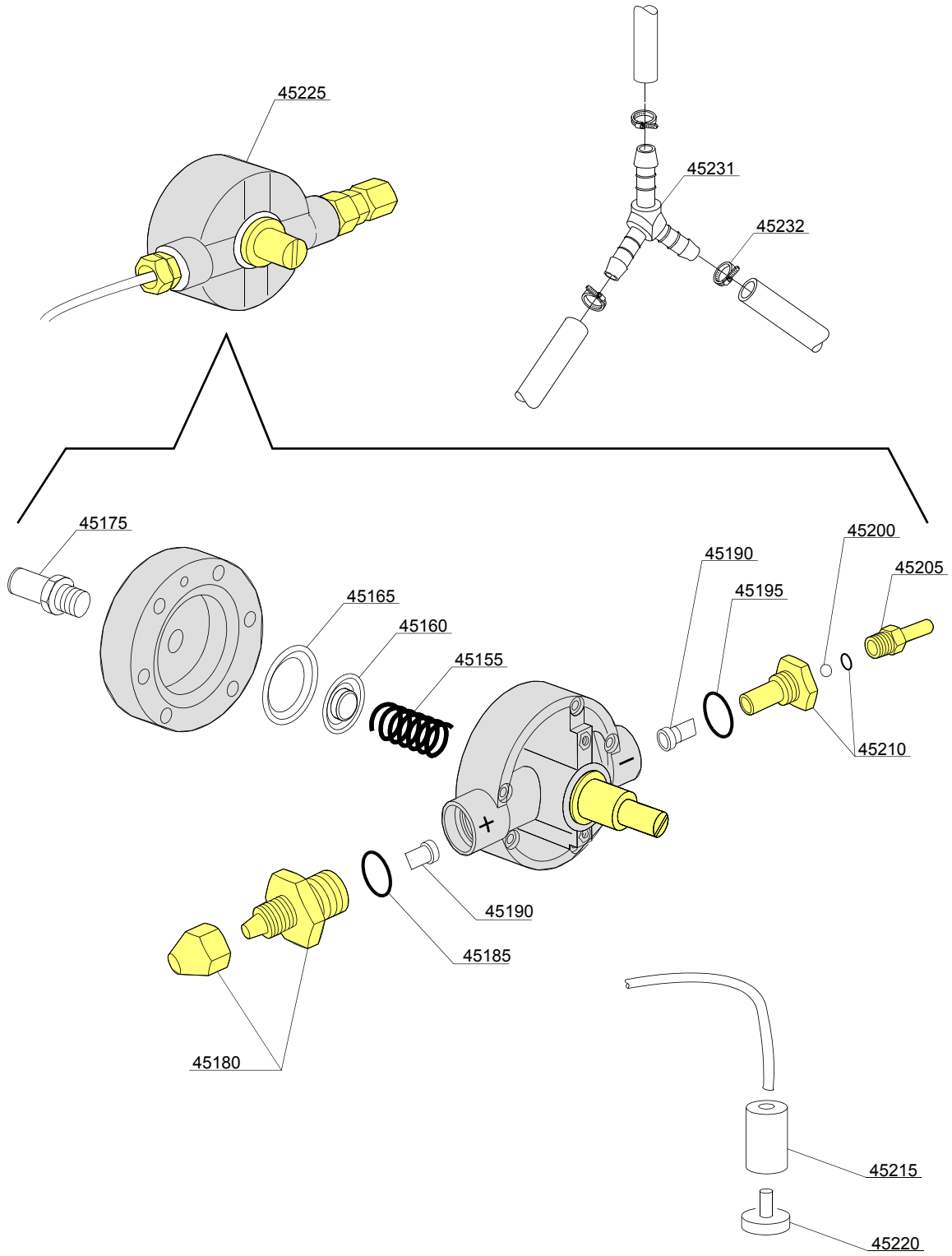

Spare parts

ID	P-code	SN from	SN to	Mod.	Acces.	Volt	Description
Module: Rinse aid dispenser group							
45155	10705/M		-	i,em			Spring
45160	10705/N		-	i,em			Disc to membrane
45165	10705/O		-	i,em			Membrane
45175	12506		-	i,em			Rubber-holder Ø 10mm
45180	10705/G		-	i,em			Pipe fitting
45185	10705/C		-	i,em			OR-gasket
45190	10705/D		-	i,em			Silicone valve
45195	10705/C		-	i,em			OR-gasket
45200	10705/T		-	i,em			Sphere made of Teflon
45205	10705/R		-	i,em			Brass pipe fitting
45210	10705/E		-	i,em			OR-gasket Guide valve
45215	12525		-	i,em			Ballast
45220	15058		-	i,em			Small filter (minimum 3 pieces)
45225	10799/G		-	i,em			GERMAC rinse aid dispenser
45231	540091		-	i,em			Ø12 mm plastic 3 ways connection
45232	11807		-	i,em			Clamp 12-22 (minimum 3 pieces)

em=ELECTROMECHANICAL SWITCHES, uw=LOWER AND UPPER WASHING, i=INSULATED MODEL
29S=29S

bt=BREAK TANK, bp=BOOSTER PUMP, dvgw=DVGW, cr=COLD RINSE, ws=WATER SOFTNER, dd=DETERGENT DISPENSER, dp=DRAIN PUMP

A=3/N/PE~380-400V 50-60Hz, D=3/PE~200-210V 50-60Hz, F=2/PE~220-240V 50-60Hz, G=3/N/PE~415V 50-60Hz, H=3/PE~220-230V 50-60Hz, K=3/PE~380-400V 50-60Hz, L=3/PE~415V 50-60Hz, M=3/PE~440V 60Hz, P=1/N/PE~220-230V 50-60Hz, R=2/PE~220-240V 50-60Hz, U=1/N/PE~240V 50-60Hz, V=3/PE~240V 50-60Hz, W=1/N/PE~100-110V 50-60Hz

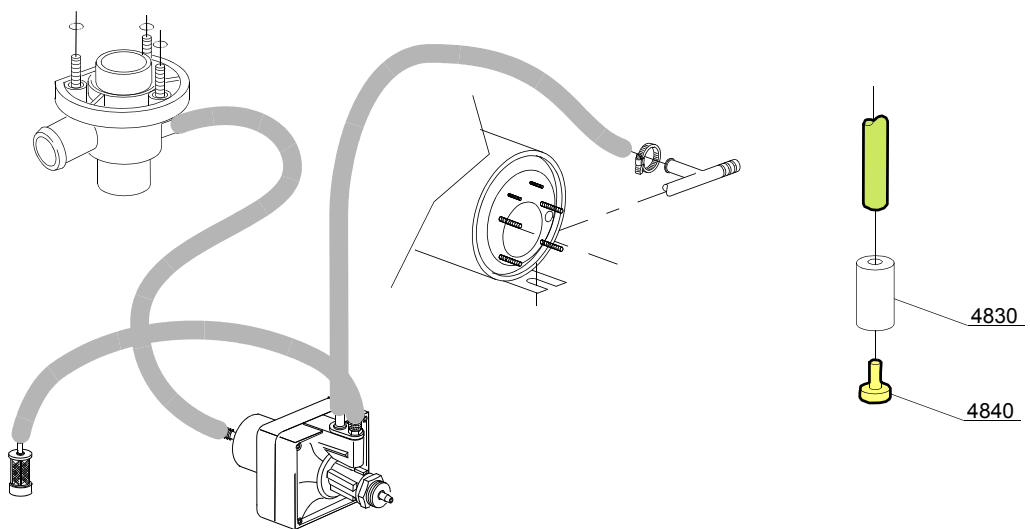
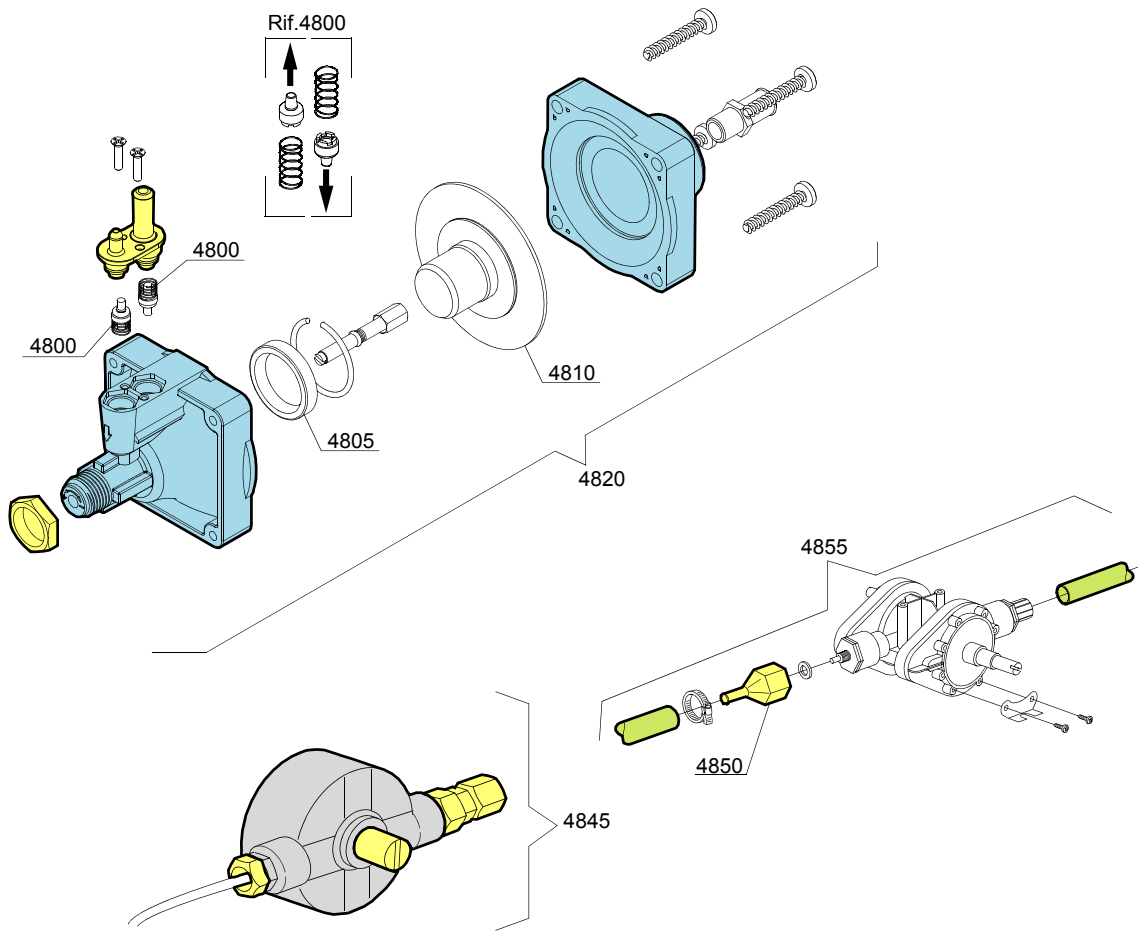

10_004_e

Spare parts

ID	P-code	SN from	SN to	Mod.	Acces.	Volt	Description
Module: Rinse aid dispenser group							
4800	10805		-	em			Tecnopro non return valve
4805	10806		-	em			Ø22 O-ring
4810	10807		-	em			Membrane
4820	10799		-	em			TECNO PRO rinse aid dispenser
4830	12525		-	em			Ballast
4840	15058		-	em			Small filter (minimum 3 pieces)
4845	10799/G		-	em			GERMAC rinse aid dispenser
4850	10798/B		-	em			Brass pipe fitting
4855	10798		-	em			LANG rinse aid dispenser

em=ELECTROMECHANICAL SWITCHES, uw=LOWER AND UPPER WASHING, i=INSULATED MODEL
29S=29S

bt=BREAK TANK, bp=BOOSTER PUMP, dvgw=DVGW, cr=COLD RINSE, ws=WATER SOFTNER, dd=DETERGENT DISPENSER, dp=DRAIN PUMP

A=3/N/PE~380-400V 50-60Hz, D=3/PE~200-210V 50-60Hz, F=2/PE~220-240V 50-60Hz, G=3/N/PE~415V 50-60Hz, H=3/PE~220-230V 50-60Hz, K=3/PE~380-400V 50-60Hz, L=3/PE~415V 50-60Hz, M=3/PE~440V 60Hz, P=1/N/PE~220-230V 50-60Hz, R=2/PE~220-240V 50-60Hz, U=1/N/PE~240V 50-60Hz, V=3/PE~240V 50-60Hz, W=1/N/PE~100-110V 50-60Hz

11_002_e

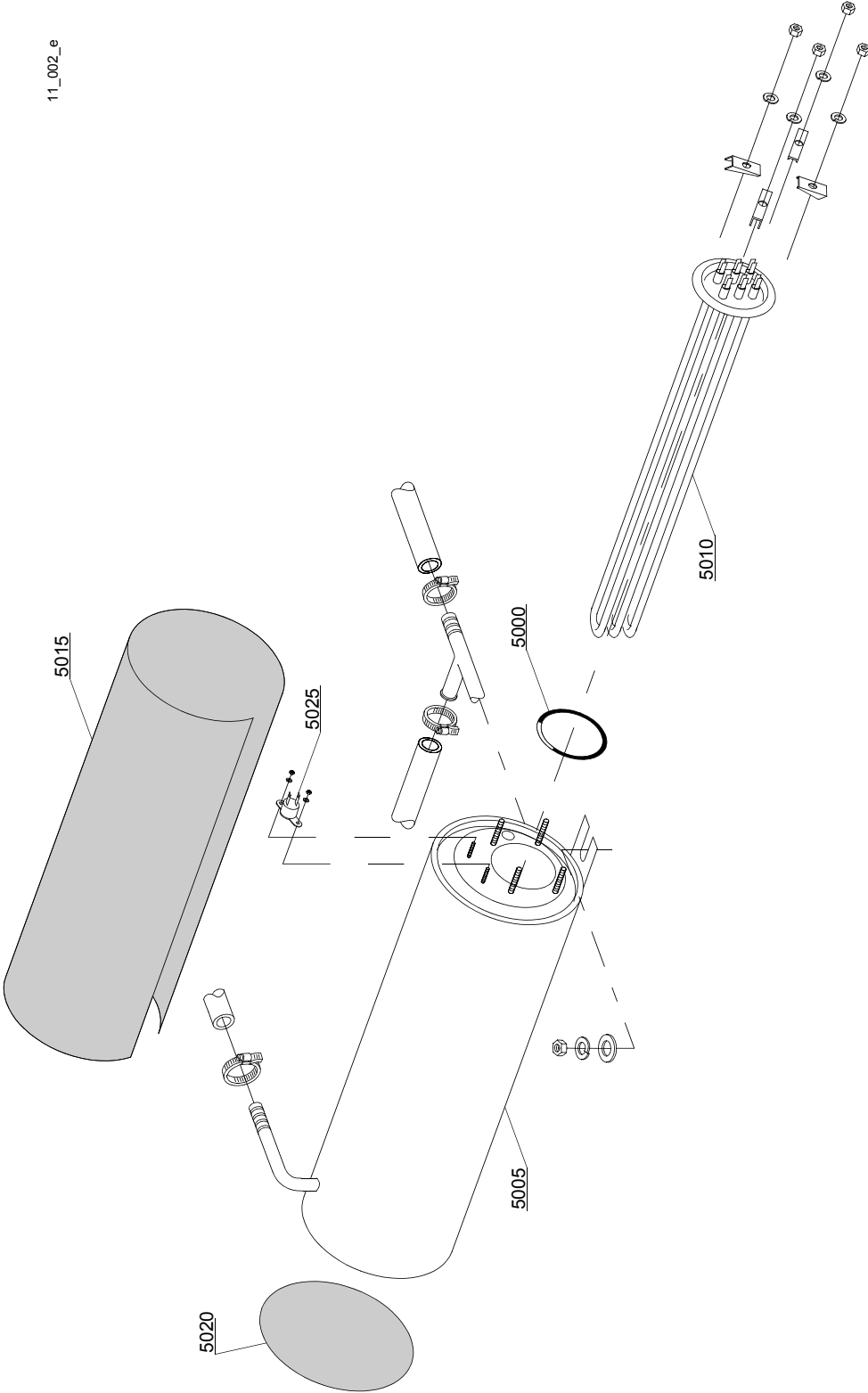

Spare parts

ID	P-code	SN from	SN to	Mod.	Acces.	Volt	Description
Module:Boiler group							
5000	13005		-	i,em			OR 151 NBR O-ring (minimum 5 pieces)
5005	150905		-	i,em			Boiler
5005	150917		-	i,em			AISI 314 boiler
5010	15089		-	i,em			4,5/4,9KW 230/240V 3 heating element
5010	15089/B		-	i,em			4,5KW heating element - 254/440Vac
5010	15089/E		-	i,em			6/6,53KW - 230/240V 3 heating element
5015	15066		-	i,em			Insulation boiler
5020	15205		-	i,em			Ø160 End piece (minimum 2 pieces)
5025	15550		-	i,em			Safety thermostat

em=ELECTROMECHANICAL SWITCHES, uw=LOWER AND UPPER WASHING, i=INSULATED MODEL
29S=29S

bt=BREAK TANK, bp=BOOSTER PUMP, dvgw=DVGW, cr=COLD RINSE, ws=WATER SOFTNER, dd=DETERGENT DISPENSER, dp=DRAIN PUMP

A=3/N/PE~380-400V 50-60Hz, D=3/PE~200-210V 50-60Hz, F=2/PE~220-240V 50-60Hz, G=3/N/PE~415V 50-60Hz, H=3/PE~220-230V 50-60Hz, K=3/PE~380-400V 50-60Hz, L=3/PE~415V 50-60Hz, M=3/PE~440V 60Hz, P=1/N/PE~220-230V 50-60Hz, R=2/PE~220-240V 50-60Hz, U=1/N/PE~240V 50-60Hz, V=3/PE~240V 50-60Hz, W=1/N/PE~100-110V 50-60Hz

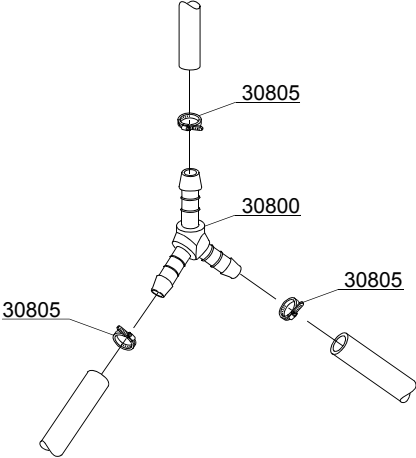

12_003ae

Spare parts

ID	P-code	SN from	SN to	Mod.	Acces.	Volt	Description
Module:3 ways connection							
30800	540091		-	i,em			Ø12 mm plastic 3 ways connection
30805	11807		-	i,em			12/22 clamp (minimum 3 pieces)

em=ELECTROMECHANICAL SWITCHES, uw=LOWER AND UPPER WASHING, i=INSULATED MODEL
29S=29S

bt=BREAK TANK, bp=BOOSTER PUMP, dvgw=DVGW, cr=COLD RINSE, ws=WATER SOFTNER, dd=DETERGENT DISPENSER, dp=DRAIN PUMP

A=3/N/PE~380-400V 50-60Hz, D=3/PE~200-210V 50-60Hz, F=2/PE~220-240V 50-60Hz, G=3/N/PE~415V 50-60Hz, H=3/PE~220-230V 50-60Hz, K=3/PE~380-400V 50-60Hz, L=3/PE~415V 50-60Hz, M=3/PE~440V 60Hz, P=1/N/PE~220-230V 50-60Hz, R=2/PE~220-240V 50-60Hz, U=1/N/PE~240V 50-60Hz, V=3/PE~240V 50-60Hz, W=1/N/PE~100-110V 50-60Hz

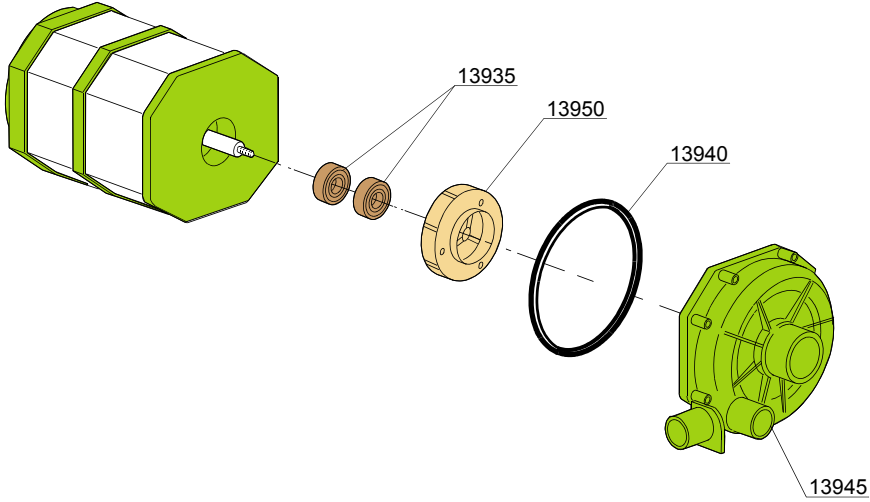
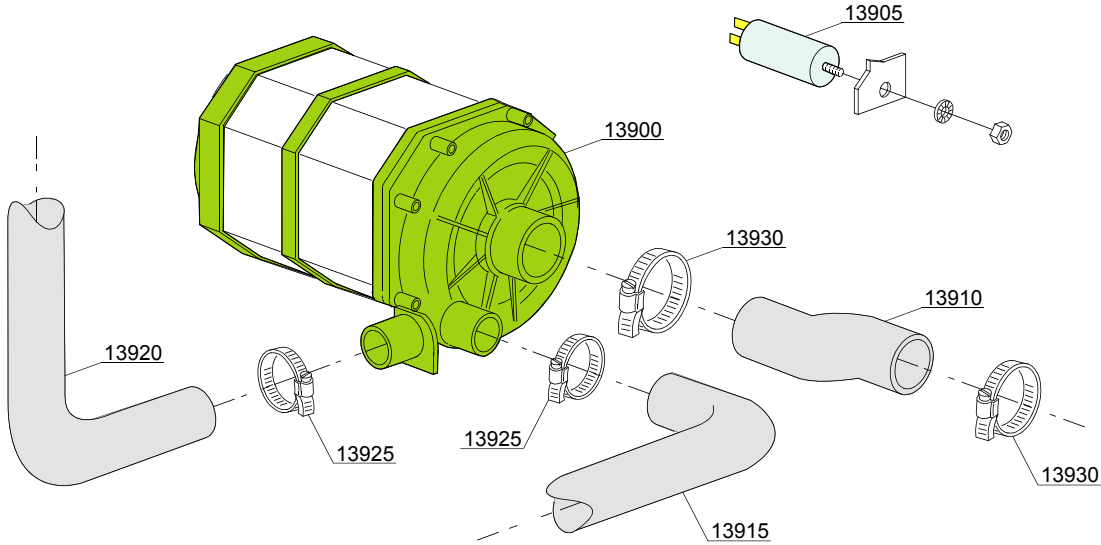

13_110_e

Spare parts

ID	P-code	SN from	SN to	Mod.	Acces.	Volt	Description
Module: Wash pump							
13900	150914		-	uw			0,70Hp wash pump - 230Vac 50Hz
13900	150915		-	uw			0,70Hp wash pump - 230Vac 60Hz
13905	15081		-	uw			12,5 uF condenser
13910	25032/A		-	uw			Suction pipe coupling
13915	150049		-	uw			Lower wash pipe coupling
13920	150048/A		-	uw			Wash ramp
13925	11806		-	uw			25/40 clamp (minimum 2 pieces)
13930	11809		-	uw			30/45 clamp (minimum 2 pieces)
13935	15080		-	uw			Rotating seals
13940	7130		-	uw			OR pump O-ring (minimum 2 pieces)
13945	16182		-	uw			Scroll
13950	15079/F		-	uw			Pump rotor

em=ELECTROMECHANICAL SWITCHES, uw=LOWER AND UPPER WASHING, i=INSULATED MODEL

29S=29S

bt=BREAK TANK, bp=BOOSTER PUMP, dvgw=DVGW, cr=COLD RINSE, ws=WATER SOFTNER, dd=DETERGENT DISPENSER, dp=DRAIN PUMP

A=3/N/PE~380-400V 50-60Hz, D=3/PE~200-210V 50-60Hz, F=2/PE~220-240V 50-60Hz, G=3/N/PE~415V 50-60Hz, H=3/PE~220-230V 50-60Hz, K=3/PE~380-400V 50-60Hz, L=3/PE~415V 50-60Hz, M=3/PE~440V 60Hz, P=1/N/PE~220-230V 50-60Hz, R=2/PE~220-240V 50-60Hz, U=1/N/PE~240V 50-60Hz, V=3/PE~240V 50-60Hz, W=1/N/PE~100-110V 50-60Hz

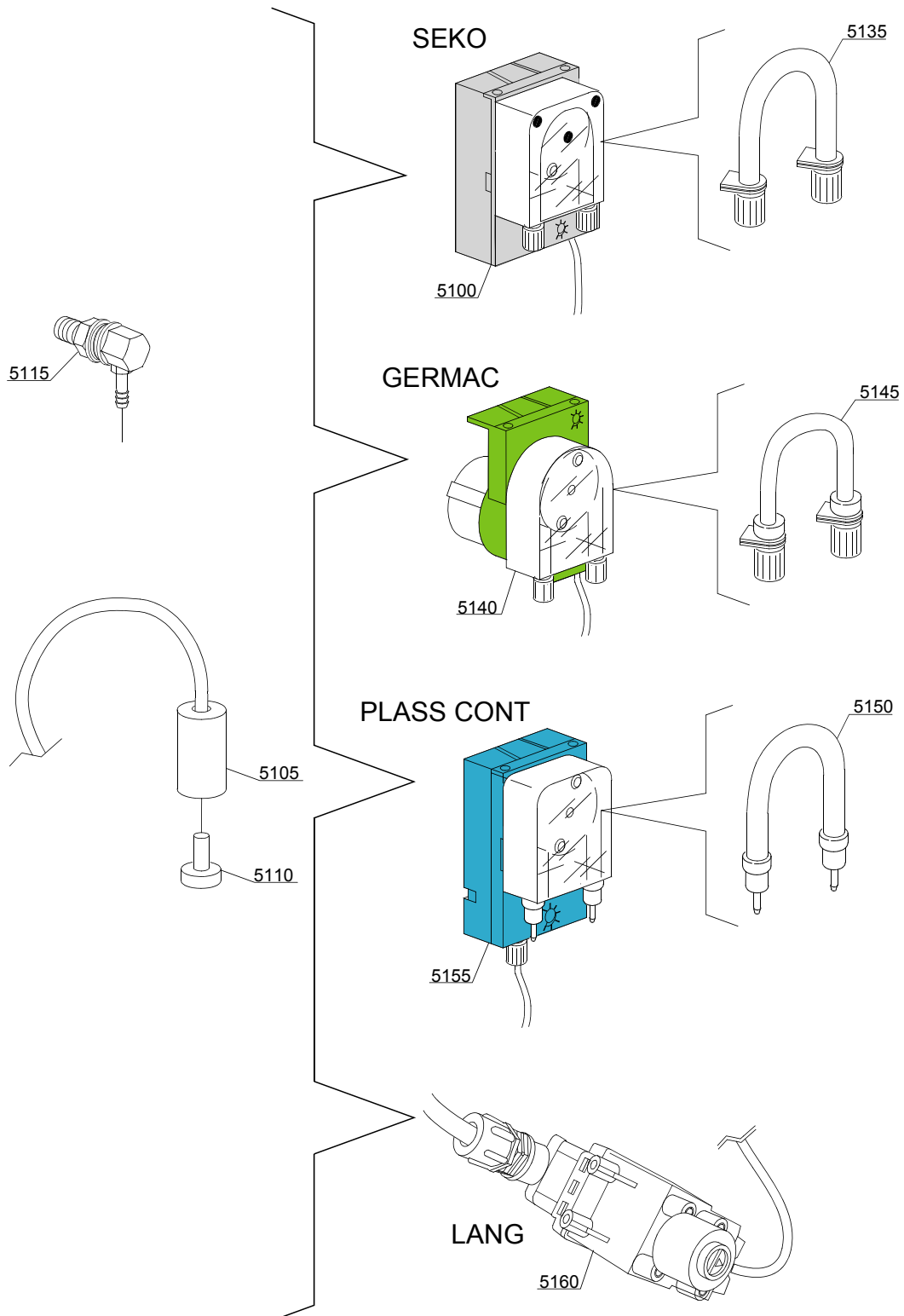

14_004_e

Spare parts

ID	P-code	SN from	SN to	Mod.	Acces.	Volt	Description
Module:Dosing detergent group							
5100	15985		-	i,em	dd		Seko detergent pump
5105	12525		-	i,em	dd		Ballast
5110	15058		-	i,em	dd		Small filter (minimum 3 pieces)
5115	15123		-	i,em	dd		Compleat stainless steel injector
5135	15185		-	i,em	dd		Seko thermoplastic pipe
5140	15985		-	i,em	dd		Germac detergent pump
5145	15108/E		-	i,em	dd		Germac thermoplastic pipe
5150	15985/A			i,em	dd		Plas Cont thermoplastic pipe
5155	15985			i,em	dd		Plas Cont detergent pump
5160	15108/L			i,em	dd		LANG detergent pump

em=ELECTROMECHANICAL SWITCHES, uw=LOWER AND UPPER WASHING, i=INSULATED MODEL
29S=29S

bt=BREAK TANK, bp=BOOSTER PUMP, dvgw=DVGW, cr=COLD RINSE, ws=WATER SOFTNER, dd=DETERGENT DISPENSER, dp=DRAIN PUMP

A=3/N/PE~380-400V 50-60Hz, D=3/PE~200-210V 50-60Hz, F=2/PE~220-240V 50-60Hz, G=3/N/PE~415V 50-60Hz, H=3/PE~220-230V 50-60Hz, K=3/PE~380-400V 50-60Hz, L=3/PE~415V 50-60Hz, M=3/PE~440V 60Hz, P=1/N/PE~220-230V 50-60Hz, R=2/PE~220-240V 50-60Hz, U=1/N/PE~240V 50-60Hz, V=3/PE~240V 50-60Hz, W=1/N/PE~100-110V 50-60Hz

15_002_e

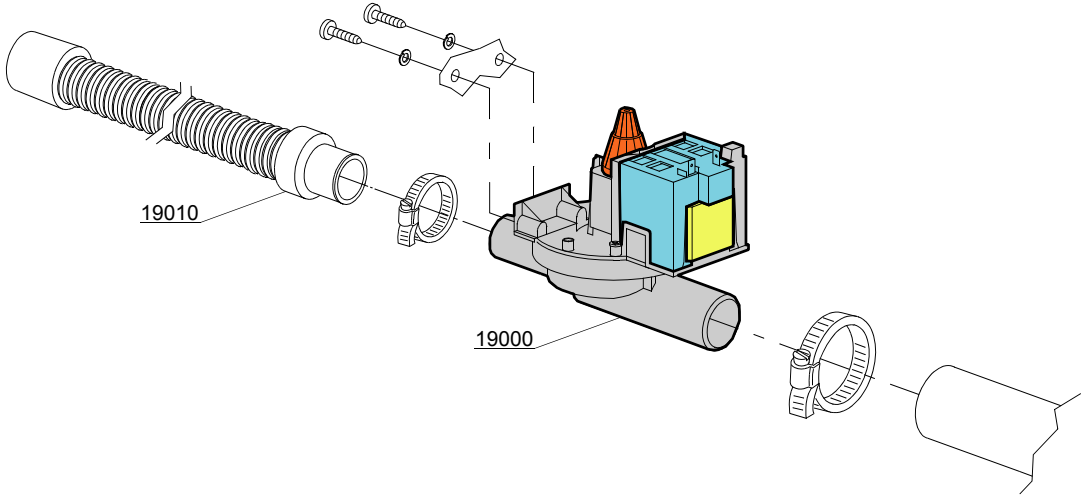

Spare parts

ID	P-code	SN from	SN to	Mod.	Acces.	Volt	Description
Module: Drain pump group							
19000	15101/A		-	i,em	dp	A	Drain pump - 50Hz
19000	15101/B		-	i,em	dp		Drain pump - 220V 60Hz
19010	10727		-	i,em	dp		Drain pipe

em=ELECTROMECHANICAL SWITCHES, uw=LOWER AND UPPER WASHING, i=INSULATED MODEL
29S=29S

bt=BREAK TANK, bp=BOOSTER PUMP, dvgw=DVGW, cr=COLD RINSE, ws=WATER SOFTNER, dd=DETERGENT DISPENSER, dp=DRAIN PUMP

A=3/N/PE~380-400V 50-60Hz, D=3/PE~200-210V 50-60Hz, F=2/PE~220-240V 50-60Hz, G=3/N/PE~415V 50-60Hz, H=3/PE~220-230V 50-60Hz, K=3/PE~380-400V 50-60Hz, L=3/PE~415V 50-60Hz, M=3/PE~440V 60Hz, P=1/N/PE~220-230V 50-60Hz, R=2/PE~220-240V 50-60Hz, U=1/N/PE~240V 50-60Hz, V=3/PE~240V 50-60Hz, W=1/N/PE~100-110V 50-60Hz

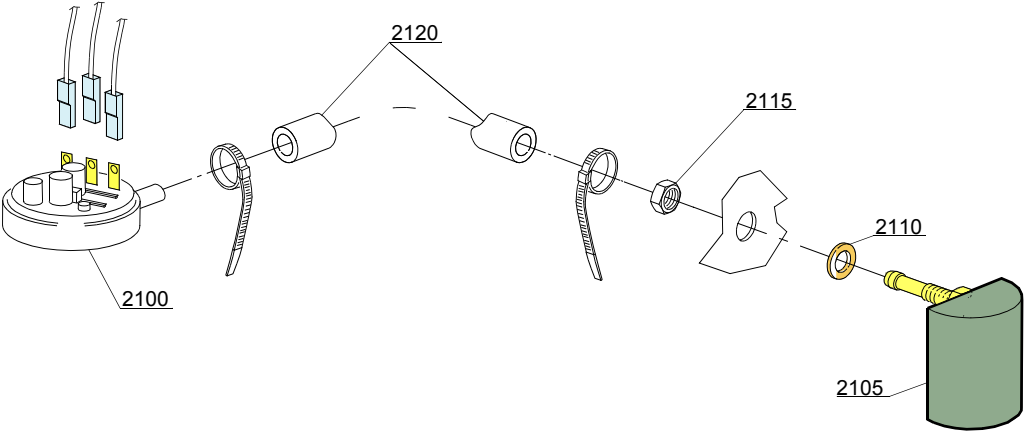

16_001_e

Spare parts

ID	P-code	SN from	SN to	Mod.	Acces.	Volt	Description
Module:Pressure switch group with air trap							
2100	10300026		-	i,em			76-38 pressure switch
2105	135911/D		-	i,em			Grey air trap assembly
2110	13301		-	i,em			O-ring (minimum 10 pieces) - D14x8x1,5
2115	11702		-	i,em			M8 stainless steel nut (minimum 10 pieces)
2120	14508		-	i,em			4,5X9 EPDM rubber hose (minimum 2mt)

em=ELECTROMECHANICAL SWITCHES, uw=LOWER AND UPPER WASHING, i=INSULATED MODEL

29S=29S

bt=BREAK TANK, bp=BOOSTER PUMP, dvgw=DVGW, cr=COLD RINSE, ws=WATER SOFTNER, dd=DETERGENT DISPENSER, dp=DRAIN PUMP

A=3/N/PE~380-400V 50-60Hz, D=3/PE~200-210V 50-60Hz, F=2/PE~220-240V 50-60Hz, G=3/N/PE~415V 50-60Hz, H=3/PE~220-230V 50-60Hz, K=3/PE~380-400V 50-60Hz, L=3/PE~415V 50-60Hz, M=3/PE~440V 60Hz, P=1/N/PE~220-230V 50-60Hz, R=2/PE~220-240V 50-60Hz, U=1/N/PE~240V 50-60Hz, V=3/PE~240V 50-60Hz, W=1/N/PE~100-110V 50-60Hz

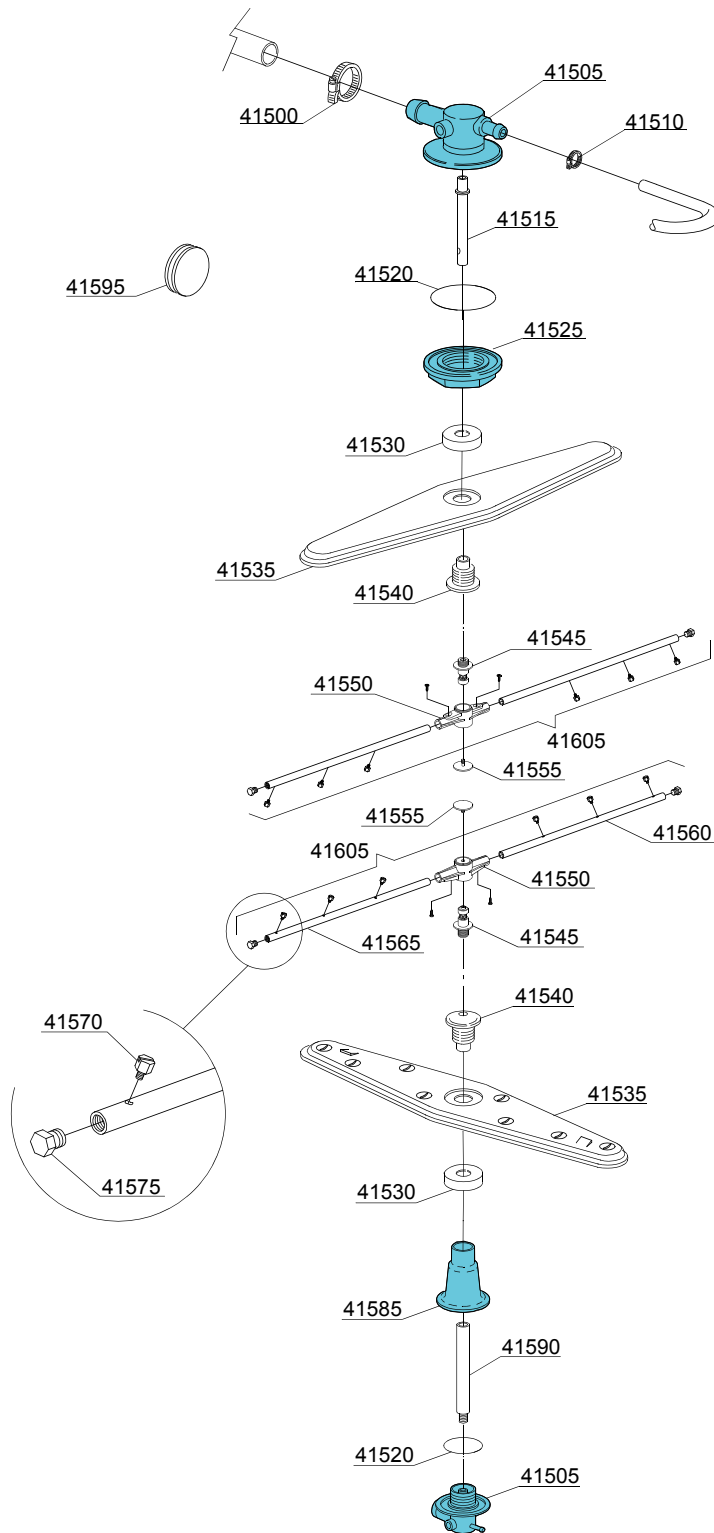

17_127_e

Spare parts

ID	P-code	SN from	SN to	Mod.	Acces.	Volt	Description
Module:Turret group with rotating arms							
41500	11806		-	uw			25/40 clamp (minimum 2 pieces)
41505	500612		-	uw			Top/lower turret
41510	11807		-	uw			12/22 clamp (minimum 3 pieces)
41515	500703		-	uw			Upper rinse axle extension
41520	13015		-	uw			6225 OR 160 NBR O-ring (minimum 5 pieces)
41525	500623		-	uw			Ring nut for fixing turret
41530	500702		-	uw			Nut for wash arm bearing 05 (inox rinse arm)
41535	500700		-	uw			Stainless steel wash rotor
41540	500701		-	uw			Hub for rotor (inox rinse arm)
41545	10651		-	uw			Rinse axle
41550	10650		-	uw			Rinse arm
41555	10652		-	uw			Rinse arm screw
41560	10657		-	uw			Right rinse arm - stainless steel nozzle
41565	10658		-	uw			Left rinse arm - stainless steel nozzle
41570	560018		-	uw			Stainless steel rinse nozzle
41575	560017		-	uw			Rinse arm plug
41580	550220		-	uw			Hub rotor/pipe coupling spacer
41585	500706		-	uw			Lower pipe coupling
41590	500705		-	uw			Rinse lower distributor connection axle
41595	13316/A		-	uw			DVGW hole O-ring
41605	75918		-	uw			Top/lower rinse arm complete

em=ELECTROMECHANICAL SWITCHES, uw=LOWER AND UPPER WASHING, i=INSULATED MODEL
29S=29S

bt=BREAK TANK, bp=BOOSTER PUMP, dvgw=DVGW, cr=COLD RINSE, ws=WATER SOFTNER, dd=DETERGENT DISPENSER, dp=DRAIN PUMP

A=3/N/PE~380-400V 50-60Hz, D=3/PE~200-210V 50-60Hz, F=2/PE~220-240V 50-60Hz, G=3/N/PE~415V 50-60Hz, H=3/PE~220-230V 50-60Hz, K=3/PE~380-400V 50-60Hz, L=3/PE~415V 50-60Hz, M=3/PE~440V 60Hz, P=1/N/PE~220-230V 50-60Hz, R=2/PE~220-240V 50-60Hz, U=1/N/PE~240V 50-60Hz, V=3/PE~240V 50-60Hz, W=1/N/PE~100-110V 50-60Hz