

TAV.206		Griglie e ventilazione	Grilles et ventilation	Grilles and ventilation	Gitter und Belüftung	FEC100	FEP080	FEM100/101/102
	Codice	Denominazione	Denominaton	Denominaton	Bezeichnung			
1	RTFOC00014	Griglia protezione ventilatore	Grille ventilateur	Fan grille	Ventilatorgitter	×	×	×
2	GAFOC00067	Convogliatore aria	Coiffée ventilateur air	Air duct	Luftförderer	×	×	×
3	RTFOC00071	Umidificatore	Humidificateur	Humidifier	Befeuchter	×	×	×
4	RTFOC00068	Resistenza elettr. 2500W 230V	Resistance elect. 2500W 230V	Over heating elect. 2500W 240V	Elektr. Widerstand 2500W 240V	×	×	×
5	RTFOC00118	Vite fissaggio girante	Vis de fixation couronne mobile	Wheel attachment serews	Laufradbefestigungsschraube	×	×	×
6	RTFOC00067	Girante ventilatore	Couronne mobile ventilateur	Fan wheel	Ventilatorlaufrad	×	×	×
7	RTFOC00066	Motore elettrico	Moteur électrique	Electric motor	E-Motor	×	×	×
8	RTFOC00156	Nebulizzatore	Nébulisateur	Atomizer	Zersträuber	×	×	×
9	RTFOC00019	Iniettore umidificatore	Injecteur humidificateur	Injecteur for humidifier	Einspritzer für Befeuchter	×	×	×
10	RTCU800183	Bicone Ø 6	Bicone pour tube Ø 6	Bicone for pipe Ø 6	Zweikegel Ø 6	×	×	×
11	RTFOC00020	Calotta Ø 6	Ecron pour tube Ø 6	Nut for pipe Ø 6	Mutter für Schlauch Ø 6	×	×	×
12	RTFOC00022	Elettrovalvola 2 vie	Electrovanne 2 voies	Solenoid valve 2 ways	E-Ventil	×	×	×
13	RTFOC00072	Tubo alimentazione umidif.	Tube alimentation	Feeding pipe	Versorgungsrohr	×	×	×
15	RTFOC00070	Griglia laterale destra	Grille latérale droite	Right lateral grate	Rechter Seitenrost	×		
15	RTFOC00178	Griglia laterale destra	Grille latérale droite	Right lateral grate	Rechter Seitenrost			×
16	RTFOC00069	Griglia laterale sinistra	Grille latérale gauche	Left lateral grate	Linker Seitenrost	×		
16	RTFOC00181	Griglia laterale sinistra (FEM101)	Grille latérale gauche (FEM101)	Left lateral grate (FEM101)	Linker Seitenrost (FEM101)			×
16	RTFOC00179	Griglia laterale sinistra (FEM100)	Grille latérale gauche (FEM100)	Left lateral grate /FEM100)	Linker Seitenrost			×
17	RTFOC00017	Griglia forno	Grille du four	Oven grate	Ofenrost	×		
17	RTFOC00175	Griglia forno	Grille du four	Oven grate	Ofenrost			×
18	RTFOC00114	Griglia laterale destra	Grille letérale droite	Right lateral grate	Rechter Seitenrost		×	
19	RTFOC00113	Griglia laterale sinistra	Grille latérale gauche	Left lateral grate	Linker Seitenrost		×	
20	RTFOC00083	Griglia forno	Grille du four	Oven grate	Ofenrost		×	
21	RTFOC00275	Termostato elettrico	Thermostat	Thermostat	Thermostat	×	×	×
22	PACP800062	Squadrette portatermostato	Eguerre de fixation thermostat	Bracket to fix thermostat	Winkel	×	×	×
23	RTFOC00120	Regolatore elettrovalvola Ø 0,25	Regulateur electrovanne Ø 0,25	Solenoid valve regulator Ø 0,25	E-Ventil Regler Ø 0,25	×	×	×
24	MPGOM10T00	Tubo gomma Ø 10x17	Tuyau Ø 10x17	Pipe Ø 10x17	Rohr Ø 10x17	×	×	×
25	RTMIN00221	Fascetta Ø 14-22	Collier Ø 14-22	Clamp Ø 14-22	Windel Ø 14-22	×	×	×

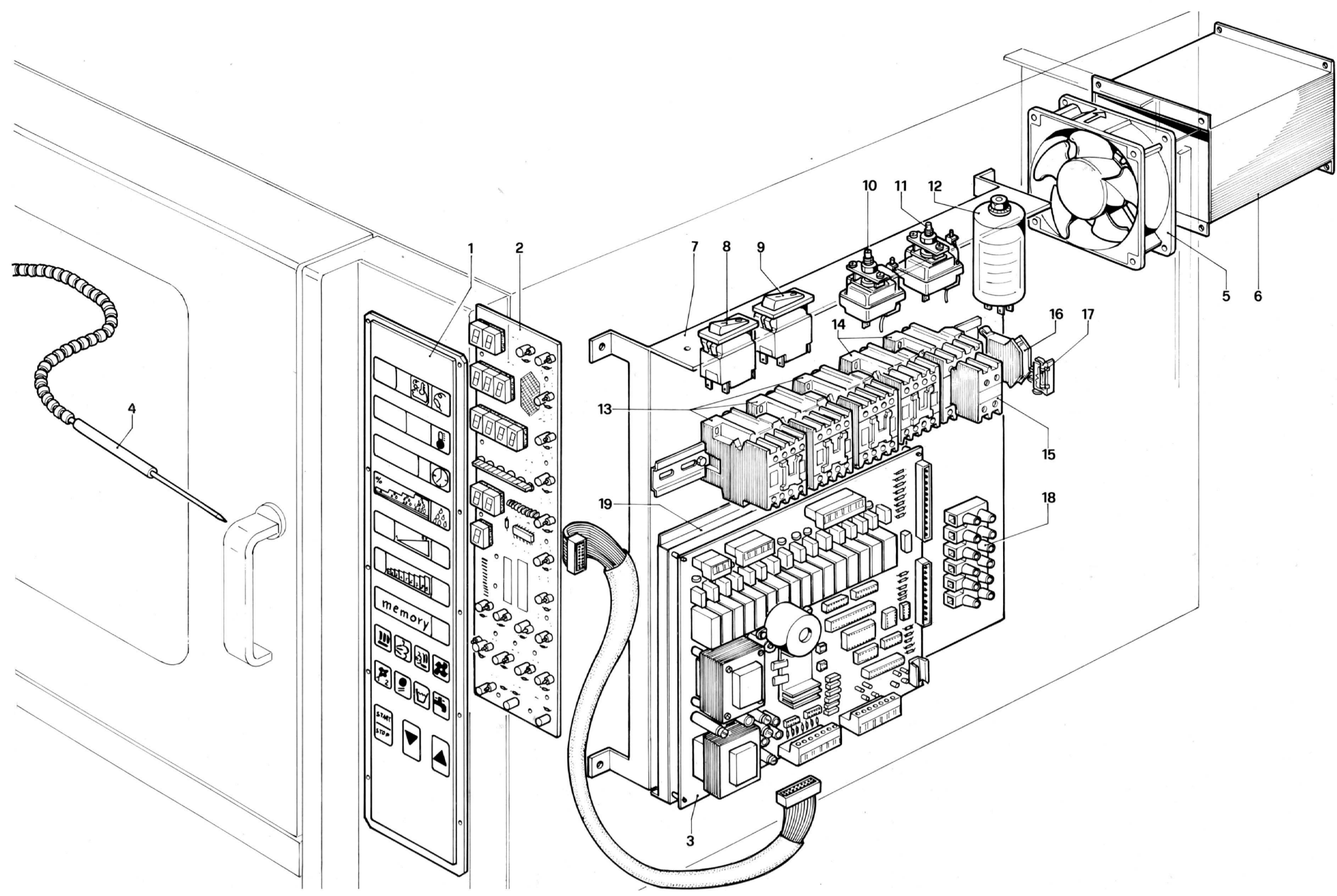

TAV.222		Apparecchiature elettriche	Appareillages électriques	Electrical equipment	Elektrogeräte	FEM062	FEM102
	Codice	Denominazione	Denominaton	Denominaton	Bezeichnung		
1	RTFOC00191	Mascherina cruscotto	Panneau de contrôle	Control panel	Steuertafel	×	×
2	RTFOC00194	Scheda elettronica comandi	Fiche électronique	Electronics card	Elektronische Komponenten	×	×
3	RTFOC00195	Scheda elettronica comandi	Fiche électronique	Electronics card	Elektronische Komponenten	×	×
4	RTFOC00130	Sonda al cuore 55cm	Sonde thermique 55cm	Thermic probe 55cm	Wärmefühler 55cm	×	
4	RTFOC00131	Sonda al cuore 82cm	Sonde thermique 82cm	Thermic probe 82cm	Wärmefühler 82cm		×
5	RTFOC00254	Motore e ventilatore	Ventilateur électrique	Electronic ventilator	Ventilatorlau	×	×
6	GAFOC00119	Convogliatore calore	Convoyeur de charleur	Heat conveyor	Wärmeförderer	×	
6	GAFOC00118	Convogliatore calore	Convoyeur de charleur	Heat conveyor	Wärmeförderer		×
7	PAFOC00029	Supporto componenti elettrici	Support composant électriques	Electrical components support	Halterung elektronischer Komponenten	×	×
8	RTFOC00044	Termica 0,8A	Interrupteur thermique 0,8A	Overload switch 0,8A	Thermostatschutzschalter 0,8A	×	
8	RTFOC00129	Termica 0,6A	Interrupteur thermique 0,6A	Overload switch 0,6A	Thermostatschutzschalter 0,6A		×
9	RTFOC00045	Termica 3A	Interrupteur thermique 3A	Overload switch 3A	Thermostatschutzschalter 3A	×	
9	RTFOC00074	Termica 1,8A	Interrupteur thermique 1,8A	Overload switch 1,8A	Thermostatschutzschalter 1,8A		×
10	RTFOC00173	Termostato Limit	Thermostat Limit	Limit thermostat	Limit Thermostat	×	×
11	RTFOC00038	Termostato Limit	Thermostat Limit	Limit thermostat	Limit Thermostat	×	×
12	RTFOC00256	Condensatore	Condensateur	Condenser	Kondensator	×	×
13	RTFOC00040	Relais FCV	Relais FCV	Relais FCV	Relais FCV	×	×
13	RTBF800153	Relais	Relais	Relais	Relais	×	×
14	RTFOC00171	Relais	Relais	Relais	Relais	×	×
15	RTFOC00041	Contatti ausiliari	Contacts auxiliaires	Auxiliary contacts	Nebenkontakte	×	×
16	RTFOC00048	Portafusibile	Porte-fusible	Fuse-holder	Sicherungshalter	×	×
17	RTFOC00284	Fusibile 6,3A	Fusibile 6,3A	Fuse 6,3A	Schmelzsicherung 6,3A	×	×
18	RTBF900045	Morsettiera 6 poli	Groupe de connection des cables	Terminal bloc 6 poles	Klemmbrett 6 polig	×	×
19	PAFOC00237	Supporto scheda elettronica	Support fiche électronique	Electronics card support	Halterung	×	×

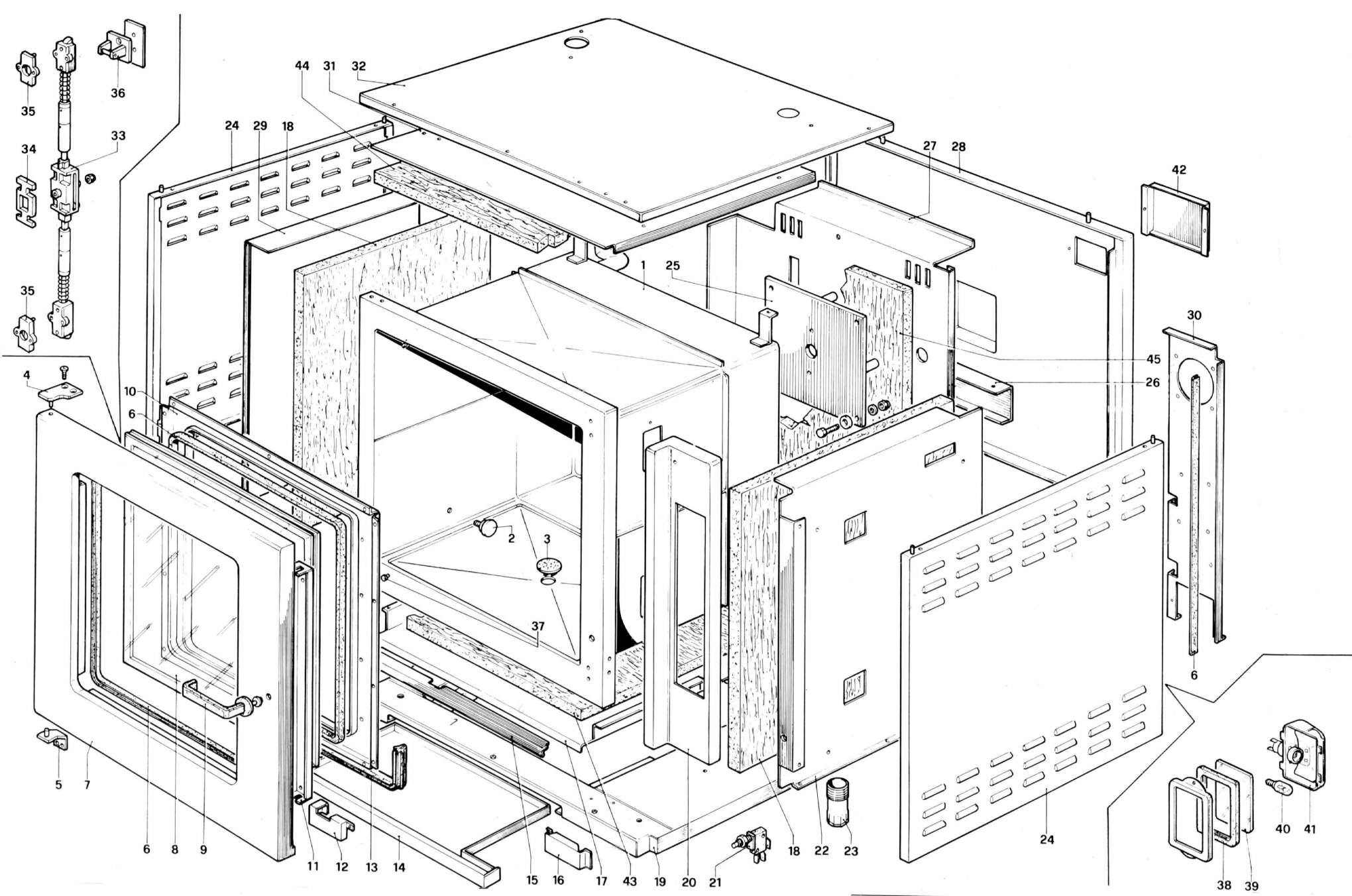

TAV.223		Struttura	Structure	Structure	Struktur	FEM102
	Codice	Denominazione	Denominaton	Denominaton	Bezeichnung	
1	GAFOC00052	Cassone forno	Caisson du four	Oven body	Ofenschubblade	×
2	RTCU700002	Attacco griglia laterale	Attaque latérale	Lateral connection	Seitenanschluß	×
3	GAFOC00027	Disco copriforo	Disque	Disk	Scheibe	×
4	GAFOC00030	Cerniera superiore porta	Charnière supérieure	Upper hinge	Linke Türangel	×
5	GAFOC00031	Cerniera inferiore porta	Charnière inférieure	Lower door hinge	Untere Türangel	×
6	MPGOM03P00	Guarnizione vetro porta	Guarniture porte	Oven door gasket	Türdichtung	×
7	GAFOC00049	Porta forno	Porte du four	Oven door	Ofentür	×
8	RTFOC00065	Cristallo porta forno	Verre porte four	Oven door glass	Ofentürglas	×
9	RTFOC00007	Maniglia serratura	Poignée porte four	Oven door handle	Ofentürgriff	×
10	PAFOC00064	Controporta forno	Contre porte du four	Oven counter door	Gegentür	×
11	PAFOC00063	Protezione serratura porta	Protection de la serrure	Lock guard	Schloßschutz	×
12	PAFOC00039	Prolunga sinistra facciata	Rollange gauche tacade	Left facade extension	Verlängerung linke Front	×
13	RTFOC00094	Guarnizione porta forno	Guarniture porte du four	Oven door gasket	Türdichtung	×
14	GAFOC00048	Cassetto	Tiroir	Drawer	Kasten	×
15	PAFOC00181	Traversa antigoccia	Traverse anti-goutte	Anti-drip crosspiece	Tropfschutzquerstange	×
16	PAFOC00038	Prolunga destra facciata	Rollange droite facade	Right facade extension	Verlängerung rechte Front	×
17	PAFOC00025	Coprilana inferiore	Panneau couvre isolant	Insulating panel cover	Isoliermaterialverkleidung	×
18	RTFOC00248	Pannello isolante laterale	Panneau isolant	Insulating panel	Isoliermaterialverkleidung	×
19	GAFOC00040	Basamento	Soubassement	Base	Untergestell	×
20	GAFOC00102	Cruscotto	Panneau de contrôle	Control panel	Stirnbrett	×
21	RTFOC00035	Microinterruttore	Microswitch	Microswitch	Microswitch	×
22	PAFOC00066	Coprilana destro	Panneau couvre isolant	Insulating panel cover	Isoliermaterialverkleidung	×
23	RTFOC00051	Piedino	Pied	Foot	Inox-Fuß	×
24	PAFOC00068	Fianco inox	Côté inox	Inox side	Inox-Seite	×
25	GAFOC00053	Supporto ventilatore	Support ventilateur	Fan support	Lautradsupport	×
26	PAFOC00026	Coprilana inf. posteriore	Panneau couvre isolant	Insulating panel cover	Isoliermaterialverkleidung	×
27	PAFOC00067	Coprilana posteriore	Panneau couvre isolant	Insulating panel cover	Isoliermaterialverkleidung	×
28	GAFOC00117	Posteriore inox	Panneau postérieur inox	Inox back panel	Inox-Rückwand	×
29	PAFOC00065	Coprilana sinistro	Panneau couvre isolant	Insulating panel cover	Isoliermaterialverkleidung	×
30	PAFOC00233	Protezione comp. elettrici.	Protection composant électriques	Electrical components guard	Schutz elektrischen Komponenten	×
31	PAFOC00140	Coprilana superiore	Panneau couvre isolant	Insulating panel cover	Isoliermaterialverkleidung	×
32	GAFOC00090	Coperchio	Couvercle	Cover	Topfdeckel	×
33	GAFOC00051	Serratura porta forno	Serrure porte four	Oven door lock	Ofentürschloß	×
34	RTFOC00057	Zoccolo centrale serratura	Prise centrale serrure	Central connection lock	Mittlerer Anschluß	×
35	RTFOC00005	Zoccolo esterno serratura	Prise extérieure serrure	External connection lock	Äußerer Anschluß	×
36	RTFOC00009	Gancio fisso serratura	Crochet fixe de la serrure	Lock fixed hook	Fester Schlossnaken	×
37	RTBF800021	Gommino porta forno	Bouchon de la porte	Door rubber cap	Türgummi	×
38	RTFOC00202	Guarnizione portalampada	Garniture	Gasket	Dichtung	×
39	RTFOC00201	Vetro portalampada	Verre protège ampoule	Lamp-holden glass	Leuchtenhalterungsglass	×
40	RTFOC00037	Lampada 25W 220V	Ampoule 25W 220V	Lamp 25W 220V	Leuchte 25W 220V	×
41	RTFOC00036	Portalampada	Douille	Lamp-holder	Leuchtenhalterung	×
42	PAFOC00234	Protezione convogliatore calore	Protection convoyeur	Heat conveyor guard	Schutz Wärmeförderer	×
43	RTFOC00247	Pannello isolante fondo	Panneau isolant fond	Bottom insulating panel	Isoliermaterialverkleidung	×
44	RTFOC00249	Pannello isolante superiore	Panneau isolant supérieur	Upper insulating panel	Linke Isoliermaterialverkleidung	×
45	RTFOC00244	Pannello isolante posteriore	Panneau isolant postérieur	Rear insulating panel	Isoliermaterialverkleidung	×

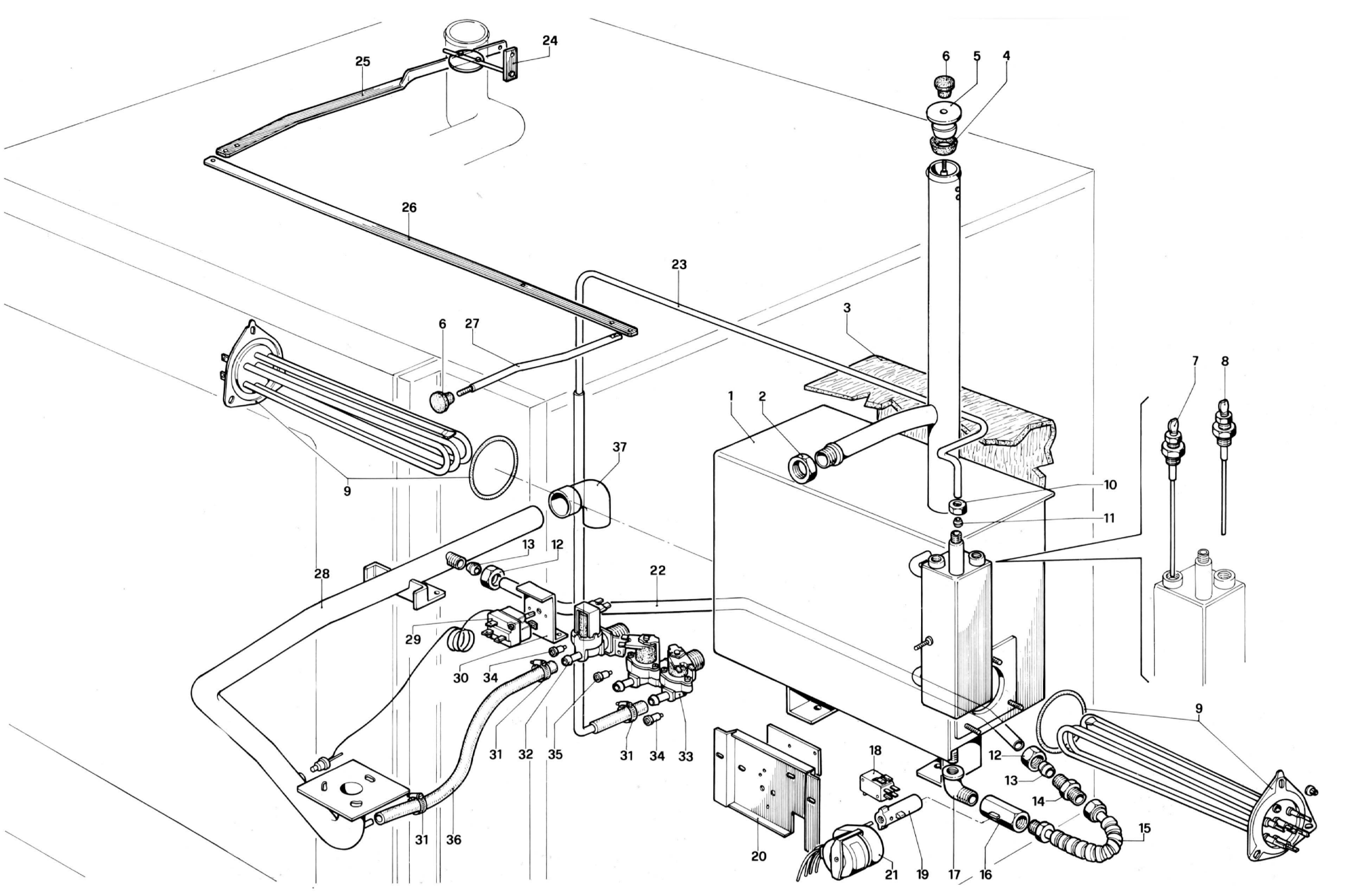

TAV. 224		Boiler elettrico	Bouilleur electric	Electric boiler	Elektroboiler	FEM102
	Codice	Denominazione	Denomination	Demonination	Bezeichnung	
1	GAFOC00084	Boiler elettrico	Bouilleur electric	Electric boiler	Elektroboiler	×
2	RTFOC00186	Dado 3/4" inox	Ecrou inox 3/4"	Inox nut 3/4"	Mutter inox 3/4"	×
3	MPISO00011	Isolante	Panneau isolant	Insulating panel	Isolier tafel	×
4	RTFOC00213	Guarnizione valvola peso	Guarniture valve	Valve gasket	Dichtung	×
5	RTFOC00212	Valvola peso	Valve	Valve	Ventil	×
6	RTFOC00056	Manopola scarico	Manette évacuation	Drain knob	Drehknopf	×
7	RTFOC00149	Sonda livello 210mm	Sonde niveau 210mm	Level probe 210mm	Niveaufühler 210mm	×
8	RTFOC00225	Sonda livello 190mm	Sonde niveau 190mm	Level probe 190mm	Niveaufühler 190mm	×
9	RTFOC00150	Resistenza elettrica 7,5kW 230V	Resistance électrique 7,5KW 230V	Oven heating electric 7,5KW 230V	Elektr. Widerstand 7,5KW 230V	×
10	RTCU900013	Calotta per tubo Ø 10	Ecrou pour tube Ø 10	Nut for pipe Ø 10	Mutter für Schlauch Ø 10	×
11	RTCU900012	Bicono per tubo Ø 10	Bicone pour tube Ø 10	Bicone for pipe Ø 10	Zweikegel Ø 10	×
12	RTCP900089	Calotta per tubo Ø 14	Ecrou pour tube Ø 14	Nut for pipe Ø 14	Mutter für Schlauch Ø 14	×
13	RTCP900088	Bicono per tubo Ø 14	Bicone pour tube Ø 14	Bicone for pipe Ø 14	Zweikegel Ø 14	×
14	RTCP900087	Nipples 1/2"-M20	Nipples 1/2"-M20	Nipples 1/2"-M20	Nippel 1/2"-M20	×
15	PACP800010	Tubo flessibile	Tube flexible	Flexible pipe	Wasserablaßrohr	×
16	RTFOC00136	Rubinetto sfera 1/2"	Robinet de decharge	Water discharge tap	Ablaßhahn	×
17	RTCP900034	Gomito MF 1/2"	Raccord MF 1/2"	Elbow 1/2"	Kniestück 1/2"	×
18	RTFOC00198	Microinterruttore	Microswitch	Microswitch	Microswitch	×
19	RTFOC00192	Albero rubinetto boiler	Arbre du robinet de decharge	Tap shaft	Hahnverlängerung	×
20	PAFOC00262	Supporto motoriduttore	Support électroréducteur	Electric motor reducer support	Halterung	×
21	RTFOC00197	Motoriduttore	Electroréducteur	Electric motor reducer	Electric motor reducer	×
22	PAFOC00204	Tubo scarico acqua	Tube de decharge de l'eau	Water discharge pipe	Wasserablaßrohr	×
23	RTFOC00228	Tubo carico acqua	Tube alimentation eau	Water feeding pipe	Versorgungsrohr	×
24	RTFOC00077	Asta attacco disco condensa	Antenne disque évacuation	Moisture drain disk rod	Kondenswasserablaßscheibe stange	×
25	RTFOC00078	Asta posteriore scarico condensa	Antenne arriere	Rear rod	Hintere Stange	×
26	RTFOC00109	Asta trasversale scarico condensa	Antenne trasversale	Transverse rod	Querstange	×
27	RTFOC00080	Asta anteriore scarico condensa	Antenne avant	Front rod	Vordere Stange	×
28	RTFOC00152	Rampa scarico condensa	Rampe évacuation condensation	Moisture drain ramp	Kondenswasserablaßrampe	×
29	RTFOC00275	Termostato elettrico abbatt.vapore	Thermostat	Thermostat	Thermostat	×
30	PACP800062	Squadretta portatermostato	Egierre de fixation thermostat	Bracket to fix thermostat	Winkel	×
31	RTMIN00221	Fascetta Ø 14-22	Collier Ø 14-22	Clamp Ø 14-22	Windel Ø 14-22	×
32	RTFOC00022	Elettrovalvola 1 via	Electrovanne 1 voie	Solenoid valve 1 way	E-ventil 1 Weg	×
33	RTFOC00203	Elettrovalvola 2 vie	Electrovanne 2 voies	Solenoid valve 2 ways	E-ventil 2 Wegs	×
34	RTFOC00145	Regolatore elettrovalvola 1,20	Regulateur electrovanne Ø 1,20	Solenoid valve regulator Ø 1,20	E-ventil Regler Ø 1,20	×
35	RTFOC00120	Regolatore elettrovalvola 0,25	Regulateur electrovanne Ø 0,25	Solenoid valve regulator Ø 0,25	E-ventil Regler Ø 0,25	×
36	MPGOM10T00	Tubo gomma Ø 10x17	Tuyau Ø 10x17	Pipe Ø 10x17	Rohr Ø 10x17	×
37	RTFOC00124	Gomiti 1"1/4 scarico condensa	Coude évacuation condensation	Moisture drain elbow	Kondenswasserablaßkniestück	×



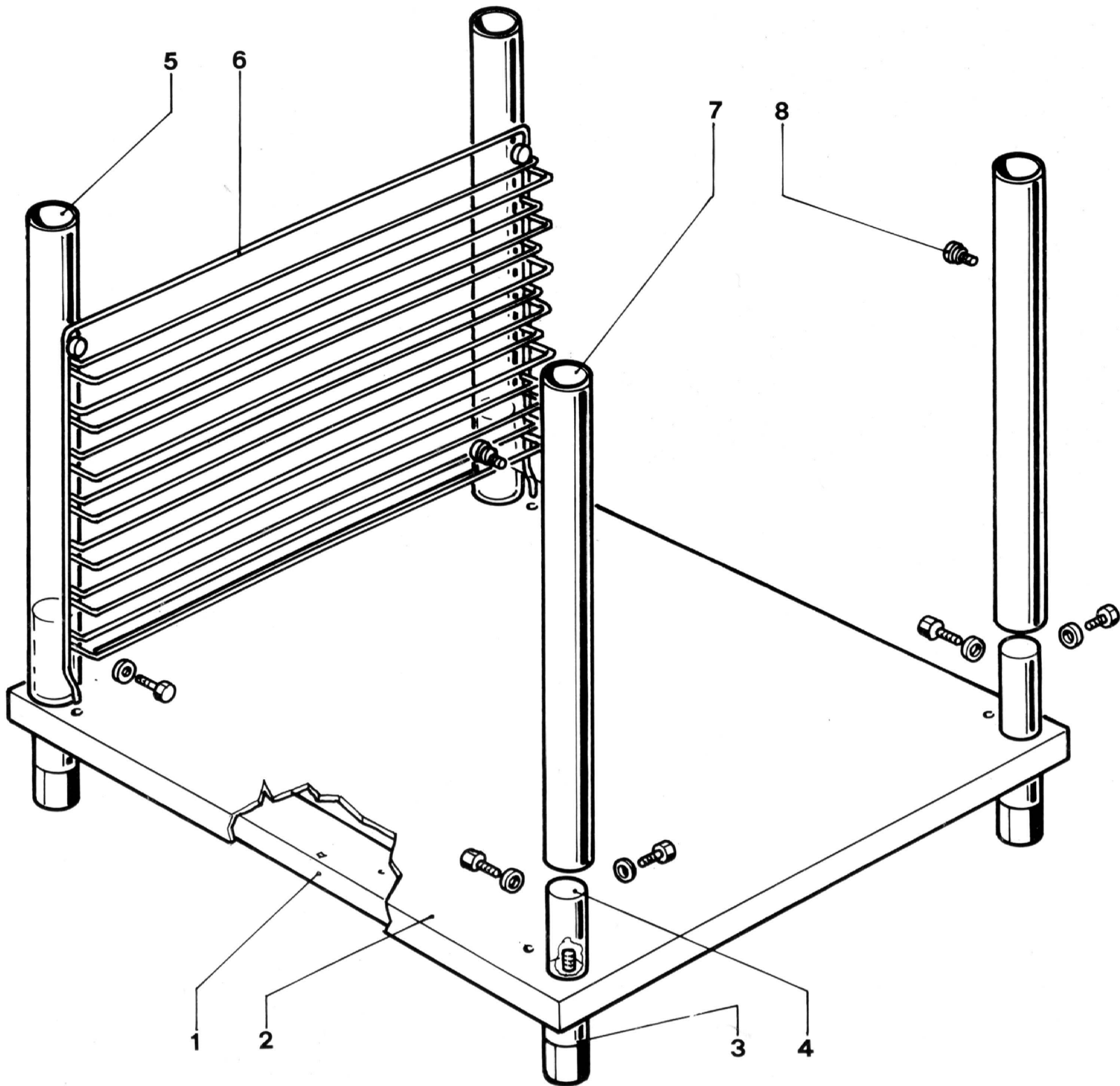

<b>TAV.204</b>		<b>Supporto forno</b>	<b>Support du four</b>	<b>Oven support</b>	<b>Ofenhalterung</b>	
	Codice	Denominazione	Denominaton	Denominaton	Bezeichnung	
1	GAFOC00077	Basamento supporto forno	Soubassement du support	Oven support base	Untergestell	×
2	PAFOC00133	Ripiano supporto forno	Fonde support du four	Oven support bottom	Boden	×
3	RTFOC00119	Piedino	Pied	Foot	Inox-Fuß	×
4	RTFOC00121	Rinforzo gamba	Rentort jambe	Leg bracing	Verstärkung	×
5	PAFOC00134	Gamba sinistra	Jambe gauche	Left leg	Linker Fuß	×
6	RTFOC00122	Griglia laterale	Grille latérale	Lateral grate	Seitenrost	×
7	PAFOC00135	Gamba destra	Jambe droite	Right leg	Rechter Fuß	×
8	RTBF700043	Attacco griglia	Attaque grille	Grate connection	Seitenanschluß	×