

# SUPERLOTUS 70≥0602

ELETTRICO / ELECTRIC / ELEKTRO / ELECTRIQUE

**F13-74ET F2/13-78ET F18-74ET F2/18-78ET≤07040723**

	1
Vedi Pagina See Page Siehe Seite Voir Page Ver Página	216

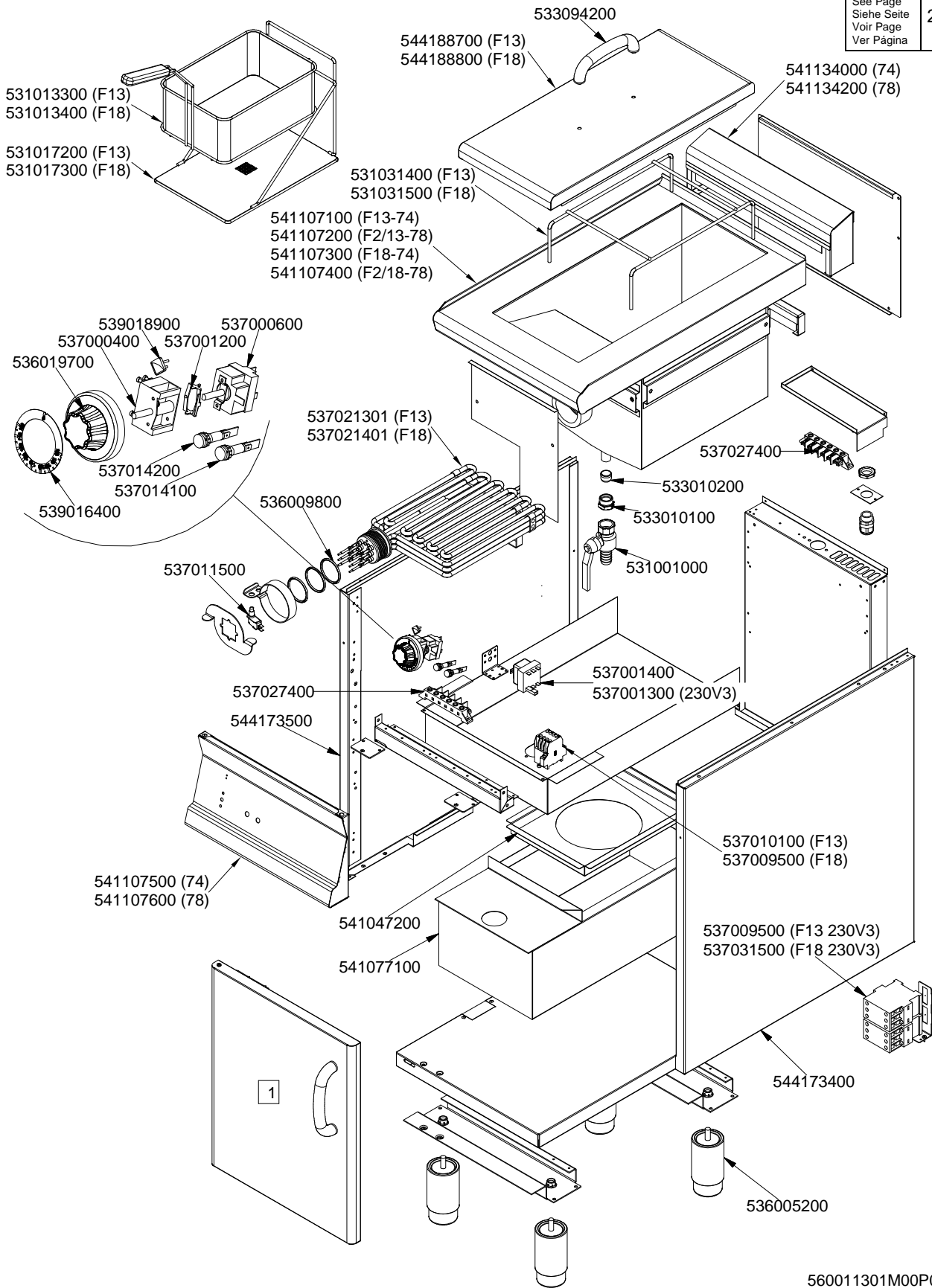

560011301M00P00

**PORTE / DOORS / FLÜGELÜREN / PORTES**

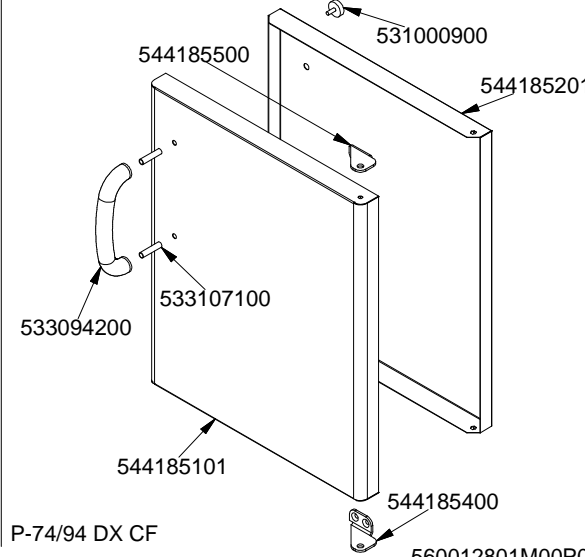
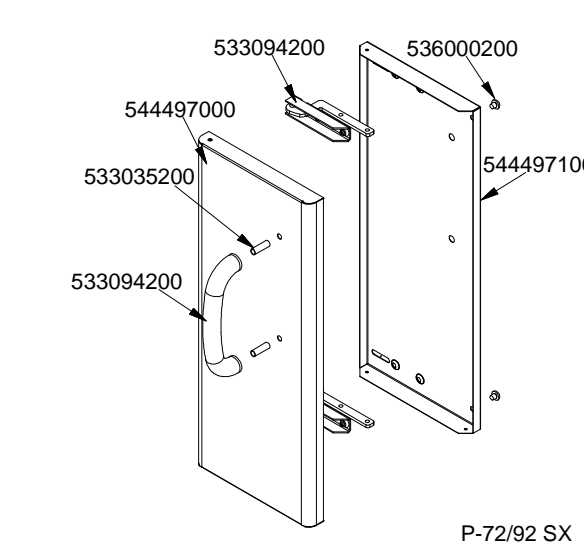
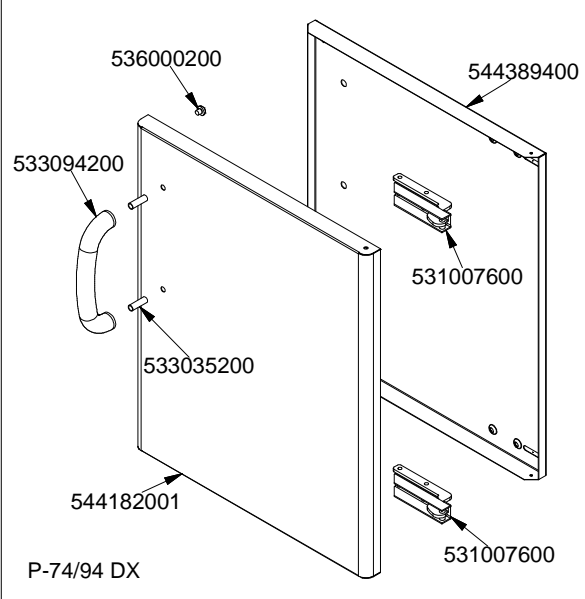
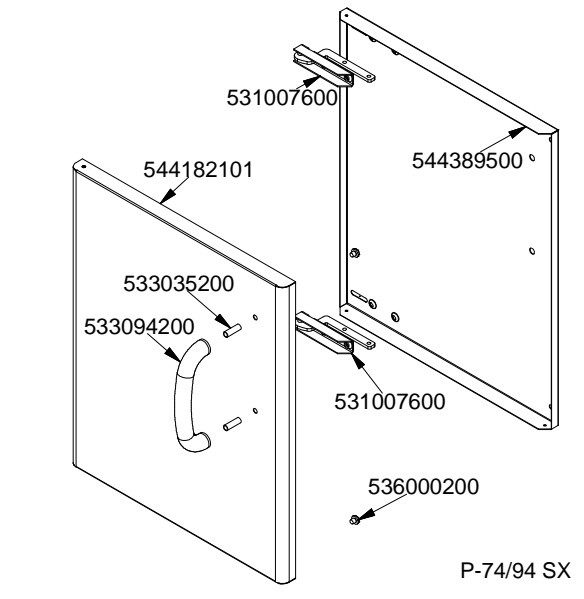
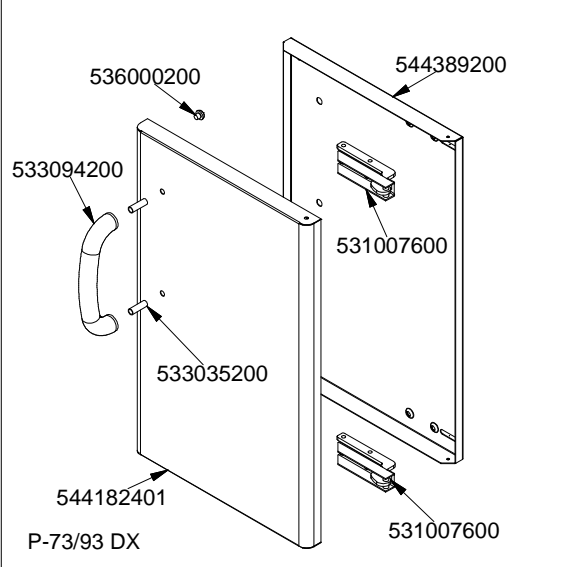
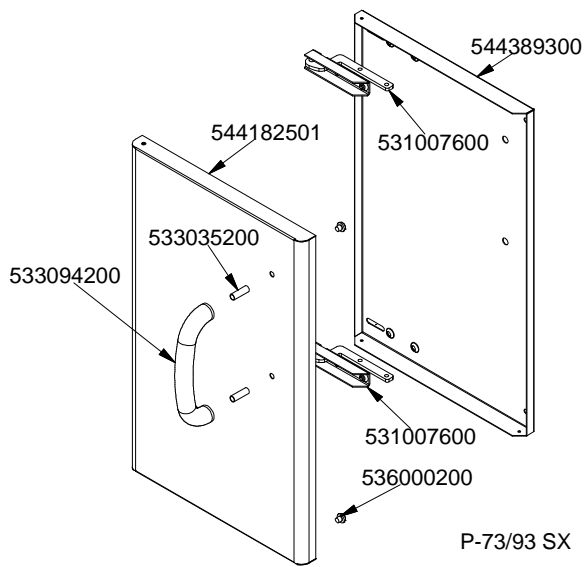

Page	Pos	Code	Description
001		533094200	S/S HANDLE FOR 70/90 SERIES
001		541134200	NEUTRAL LOW SPACER 78
001		541107200	UPPER PLATE F2/13-78E
001		537000600	THERMOSTAT 90-180°C SINGLEPHASE
001		537001200	FIXING BRACKET FOR THERMOSTAT/COMM.
001		539018900	INDEX FOR KNOB
001		537000400	COMMUTATOR 1POS.SINGLEPHASE S49 16A
001		536019700	BLACK KNOB §70 PIN §6*5
001		537014200	GREEN WARNING LIGHT 250V
001		537014100	WHITE WARNING LIGHT 250V
001		539016400	ADHESIVE GRADUATED DISC FOR KNOB
001		536009800	GASKET O-RING 47,22X3,53 VITON
001		537011500	MICRO-SWITCH 16A
001		537027400	TERMINAL BLOCK THREEPHASE 40A
001		533010200	BICONE 18S
001		533010100	3/4 D. 18 PIPE UNION
001		531001000	DRAIN COCK 3/4" + HANDLE
001		537001400	SAFETY THERMOSTAT 235°C THREEPHASE
001		537001300	SAFETY THERMOST.235°C SINGLEPH+NUT
001		544173500	LEFT SIDE PANEL S.70
001		541107600	CONTROL PANEL F2/13/18-78E
001		541047200	FILTER FOR DRIP TRAY
001		541077100	FILTER FOR DRIP TRAY 23L
001		544173400	RIGHT SIDE PANEL S.70
001		536005200	INOX LEG 2" 120-180 M10
002		544389300	
002		531007600	DOOR HINGE
002		544182501	LEFT DOOR 73
002		533035200	
002		533094200	S/S HANDLE FOR 70/90 SERIES
002		536000200	D.12 H.4 BUMPER
002		544389200	
002		544182401	RIGHT DOOR 73
002		544389500	INNER-DOOR OF LHD 74
002		544182101	LEFT DOOR 74
002		544389400	
002		544182001	RIGHT DOOR 74
002		544497100	
002		544497000	
002		531000900	MAGNET §22 KG.3 WITH DISK
002		544185500	UPPER DOOR HINGE FOR COMPARTME CF70
002		544185201	
002		533107100	
002		544185101	RIGHT DOOR 74 CF
002		544185400	LOWER DOOR HINGE FOR COMPARTME CF70