



**Kochgeräte
Elektro Fritteusen Serie 700**

Artikel-Nr. 134201, 134203, 134205
(418031-352250XI, -354350XI, -356450XI)

Ersatzteile

8. Ersatzteile

Außenteile31

Innere Bestandteile.....33

8.1 Spannungscodes

Spannung	Spannungscodes
A	3/N/PE~400/230V 50Hz
B	~250V 16A 50Hz
C	3/N/PE~380/220V 50Hz
D	3/PE~200V 50-60Hz
F	2/PE 220-240V 50Hz
G	3/N/PE~415/240V 50Hz
H	3/PE~230V 50Hz
I	3/PE~220V 60Hz
J	3/PE~380 50Hz
K	3/PE~400V 50Hz
L	3/PE~415V 50Hz
M	3/PE~440V 60Hz
N	3/PE~460V 60Hz
O	3/PE~480V 60Hz
P	1/N/PE~220-240V 50Hz
R	2/PE~220-230V 60Hz
S	3/N/PE~400/230V 50Hz
T	3/PE~230V 60Hz
U	1/N/PE~100V 50-60Hz

8.2 Produktcodes

Produktcode	Ernennung
Modellcodes	
Typecodes	
415	134001
610	134003
815	134005
Zubehörcodes	

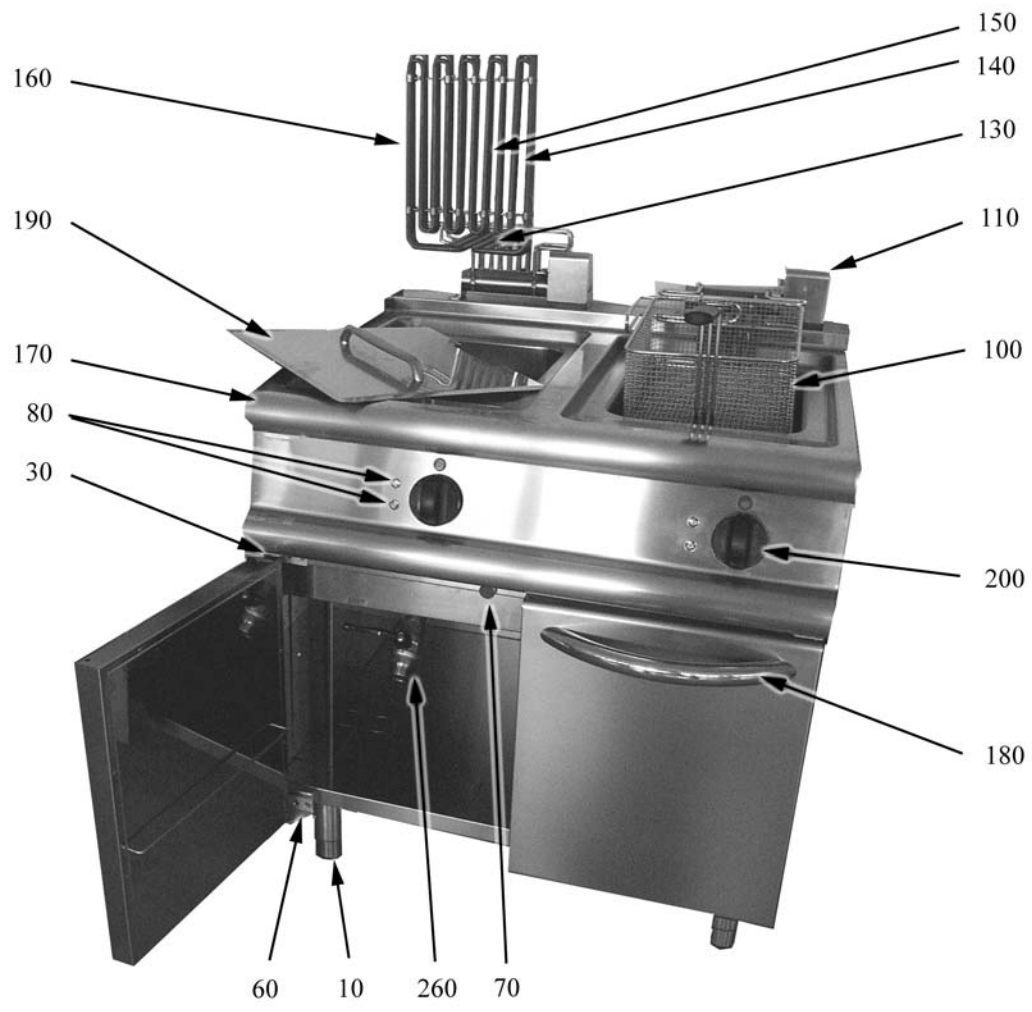

ID	Typ	Beschreibung	p-code
Module: Aussenteile			
10		Fuss	826490142
30		Untere rechte tuerscharniere	2547870
60		Untere rechte tuerscharniere	2547860
70		Magnet	826900011
80		Weisses Glass	6A039207
100	415,815	Korb	418031940180
100	610	Korb	418031940170
110		Mikroschalter	6A039800
130		Befestigungsklemmen des Kapillarrohrs	8208270
140		Clips ø6	8208250
150		Clips ø4	8208260
160	610	Winderstand 9 kW	9000482
160	415,815	Winderstand 13 kW	9000483
170	415	Beckenplatte	826135260
170	610	Beckenplatte	826135270
170	815	Beckenplatte	826135290
180	415	Handgriff	826430010
180	610	Handgriff	826430080
190	415,815	Deckel	821450700
190	610	Deckel	821450710
200		Schwarzer Knebel fuer elektrische Friteusen	824710680X
260		Schieber	6A023010

415=134001, 610=134003, 815=134005

A=3/N/PE~400/230V 50Hz, H=3/PE~230V 50Hz

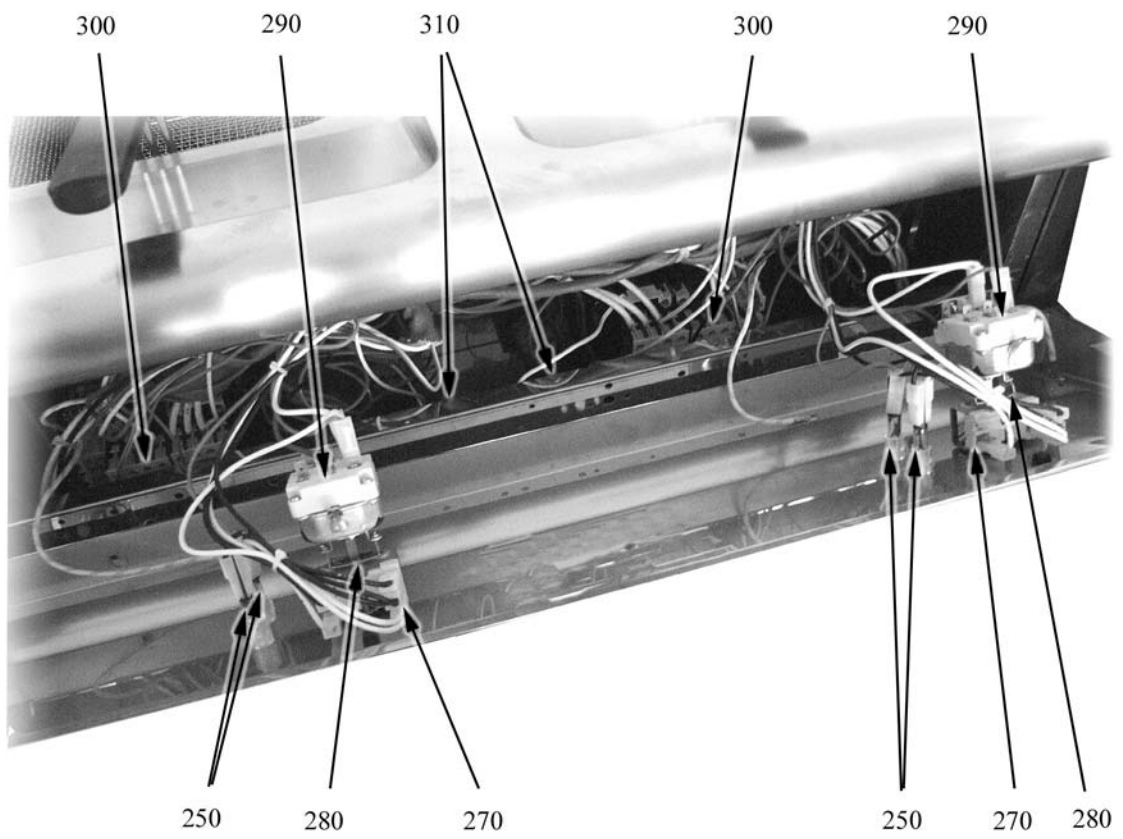

ID	Typ	Beschreibung	p-code
Module:Innenteile			
250		Lampe	826650050
250		Lampe	6A038506
270	610	Hauptschalter	6A046001
270	415,815	Hauptschalter	6A046000
280	815	Halteuegel	6A045900
280	610	Halteuegel	6A045000
280	415	Halteuegel	41821550060
290		Thermostat	8219601
310		Sicherheitsthermostat	8219602

415=134001, 610=134003, 815=134005

A=3/N/PE~400/230V 50Hz, H=3/PE~230V 50Hz