

CLASSICA

TAV. 908

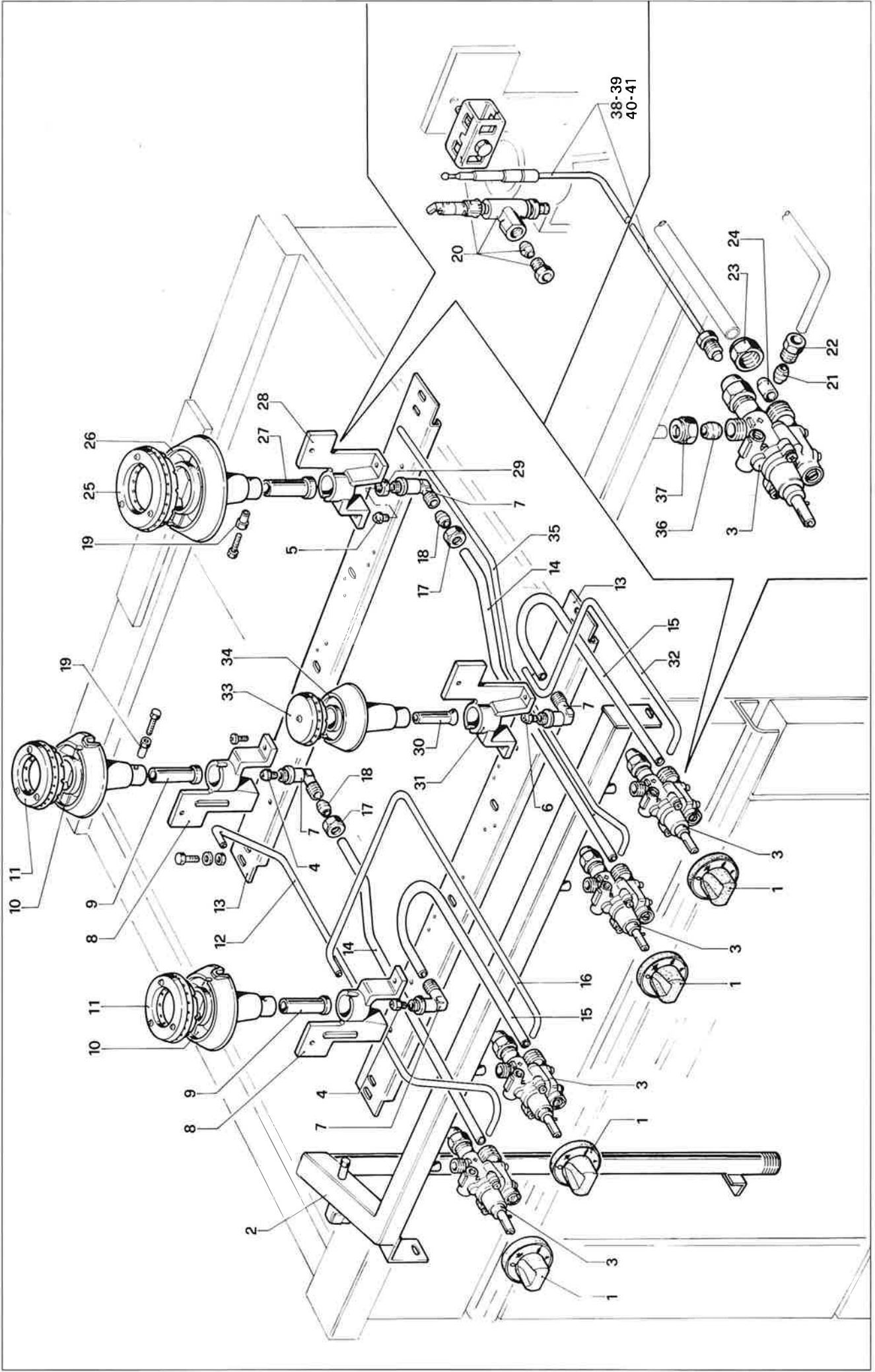



CLASSICA

TAV. 909



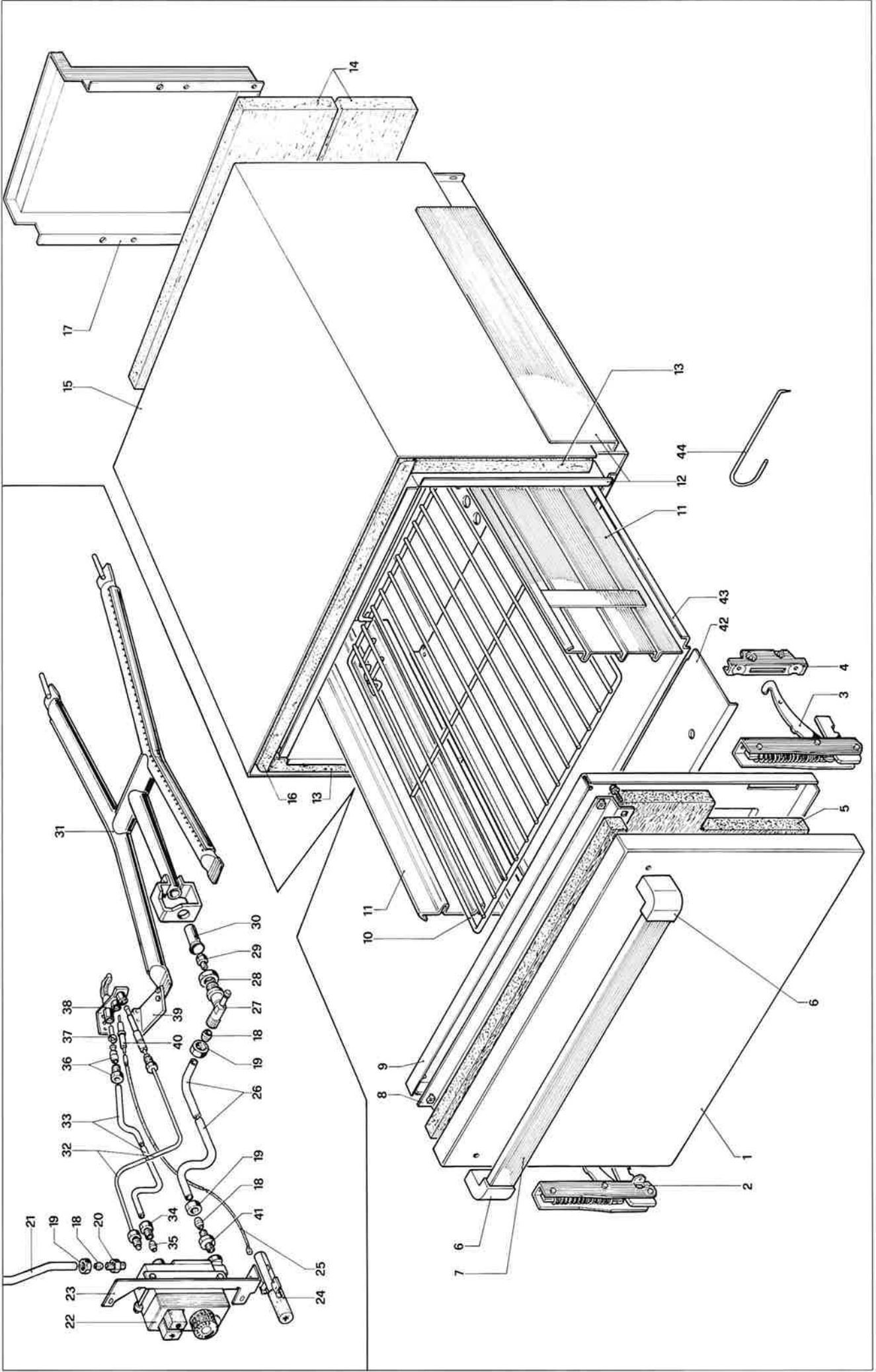

	Codice	Denominazione	Denomination	Denomination	C4F	C6F	C6ZF	C6FA	C8F
1	PACU900001	Porta forno	Porte du four	Oven door	●	●	●	●	●
2	RTC900027	Cerniera porta sinistra	Charnière gauche porte du four	Oven door left hinge	●	●	●	●	●
3	RTC900026	Cerniera porta destra	Charnière droite porte du four	Oven door right hinge	●	●	●	●	●
4	RTC900004	Porta rullino cerniera	Support charnière	Hinge support	●	●	●	●	●
5	PACU900004	Pannello isolante porta	Panneau isolant porte du four	Insulating panel oven door	●	●	●	●	●
6	RTC900029	Terminale maniglia	Terminal poignée	Handle terminal	●	●	●	●	●
7	PACU900005	Maniglia porta	Poignée porte four	Oven door handle	●	●	●	●	●
8	PACU900003	Distanziale porta	Entretoise porte	Door spacer	●	●	●	●	●
9	PACU900002	Controporta forno	Contre porte du four	Oven counter door	●	●	●	●	●
10	RTC800028	Griglia forno	Grille du four	Oven grate	●	●	●	●	●
11	GACU900018	Laterale forno	Panneau latéral du four	Oven lateral panel	●	●	●	●	●
12	GACU900024	Cassone forno	Caisson four	Oven covering	●	●	●	●	●
13	PACU900421	Pannello isolante laterale	Panneau isolant latéral four	Insulating lateral oven panel	●	●	●	●	●
14	PACU900422	Pannello isolante posteriore	Panneau isolant base four	Insulating posterior oven panel	●	●	●	●	●
15	PACU900069	Coprilana	Panneau couvre isolant du four	Wrapping insulating panel	●	●	●	●	●
16	PACU900068	Pannello isolante superiore	Panneau isolant superieur caisson	Insulating superior oven panel	●	●	●	●	●
17	PACU900089	Parete caminetto interno	Cheminée intérieure	Internal chimney	●	●	●	●	●
18	RTC900012	Bicono per tubo Ø 10	Bicone pour tube Ø 10	Bicone for pipe Ø 10	●	●	●	●	●
19	RTC900013	Calotta tubo Ø 10	Écrou pour tube Ø 10	Nut for pipe Ø 10	●	●	●	●	●
20	RTC900132	Niples 1/2" x 3/8"	Niples 1/2" x 3/8"	Niples 1/2" x 3/8"	●	●	●	●	●
21	PACU900095	Tubo alimentazione valvola	Tune de distribution soupape	Valve distribution pipe	●	●	●	●	●
22	RTC900064	Valvola gas	Soupape à gaz	Gas valve	●	●	●	●	●
22	RTC900063	Valvola gas	Soupape à gaz	Gas valve			●		
23	PACU900441	Squadretta sinistra porta valvola	Egierre gauche pour soupape	Left bracket to fix gas valve	●	●		●	
23	PACU900553	Squadretta destra porta valvola	Egierre droite pour soupape	Right bracket to fix gas valve			●		
23	PACU900440	Squadretta destra porta valvola	Egierre droite pour soupape	Right bracket to fix gas valve					●
24	RTC900020	Accenditore piezo	Allumage piezo	Piezolighting	●	●	●	●	●
25	RTC900384	Cavo accensione	Cable d'allumage	Lighting cable	●	●	●	●	●
26	PACU900063	Tubo alimentazione bruciatore	Tube d'alimentation brûleur four	Feeding pipe oven burner	●	●	●	●	●
27	RTC900337	Supporto iniettore forno	Support injecteur du four	Injector support	●	●	●	●	●
28	RTC900078	Controdado	Contre écrou	Lock nut	●	●	●	●	●
29	RTC900235	Iniettore Ø 1.45 K per GPL	Injecteur Ø 1.45 K pour GPL	LPG gas injector Ø 1.45 K	●	●	●	●	●
29	RTBF900017	Iniettore Ø 2.20 L per gas metano	Injecteur Ø 2.20 L pour méthane	Methane injector Ø 2.20 L	●	●	●	●	●
30	PACU900138	Regolatore aria	Dispositif de réglage d'admission d'air	Air regulator burner	●	●	●	●	●
31	RTC900058	Bruciatore forno	Brûleur four	Oven burner	●	●	●	●	●
32	RTC900060	Termocoppia cm. 75	Thermocouple cm. 75	Thermocouple cm. 75	●	●	●	●	●
33	PACU900105	Tubo pilota forno	Tube veilleuse four	Oven pilot pipe	●	●	●	●	●
34	RTC800182	Raccordo Ø 6 per tubo pilota	Écrou Ø 6 pour veilleuse	Nut Ø 6 for pilot	●	●	●	●	●
35	RTC800183	Bicono per tubo Ø 6	Bicone pour tube Ø 6	Bicone for pipe Ø 6	●	●	●	●	●
36	RTC900217	Raccordo + bicono Ø 6	Écrou + bicone Ø 6	Nut + bicone Ø 6	●	●	●	●	●
37	RTCP800041	Iniettore pilota Ø 0.19 K per GPL	Injecteur veilleuse Ø 0.19 K pour GPL	LPG gas injector Ø 0.19 K	●	●	●	●	●
37	RTCP800040	Iniettore pilota Ø 0.36 K gas metano	Injecteur veilleuse Ø 0.36 K pour méthane	Methane injector Ø 0.36	●	●	●	●	●
38	RTCP800034	Corpo pilota 3 vie	Veilleuse 3 voies	3-ways pilot	●	●	●	●	●
39	PACU900500	Squadretta porta pilota	Egierre pour veilleuse	Bracket to fix pilot	●	●	●	●	●
40	RTCP800033	Candela rotonda	Bougie oxide tonde	Oxide spark plug	●	●	●	●	●
41	RTC900220	Raccordo 3/8"	Raccord 3/8"	Fitting 3/8"	●	●	●	●	●
42	PACU900010	Piano anteriore forno	Plan du four antérieur	Front oven plan	●	●	●	●	●
43	PACU900212	Piano forno	Plan du four	Oven plan	●	●	●	●	●
44	RTC900030	Ferro di manovra	Crochet de déplacement	Removal hook	●	●	●	●	●