

IF IN DOUBT ASK!!

DO NOT SCALE !!

First Angle Projection

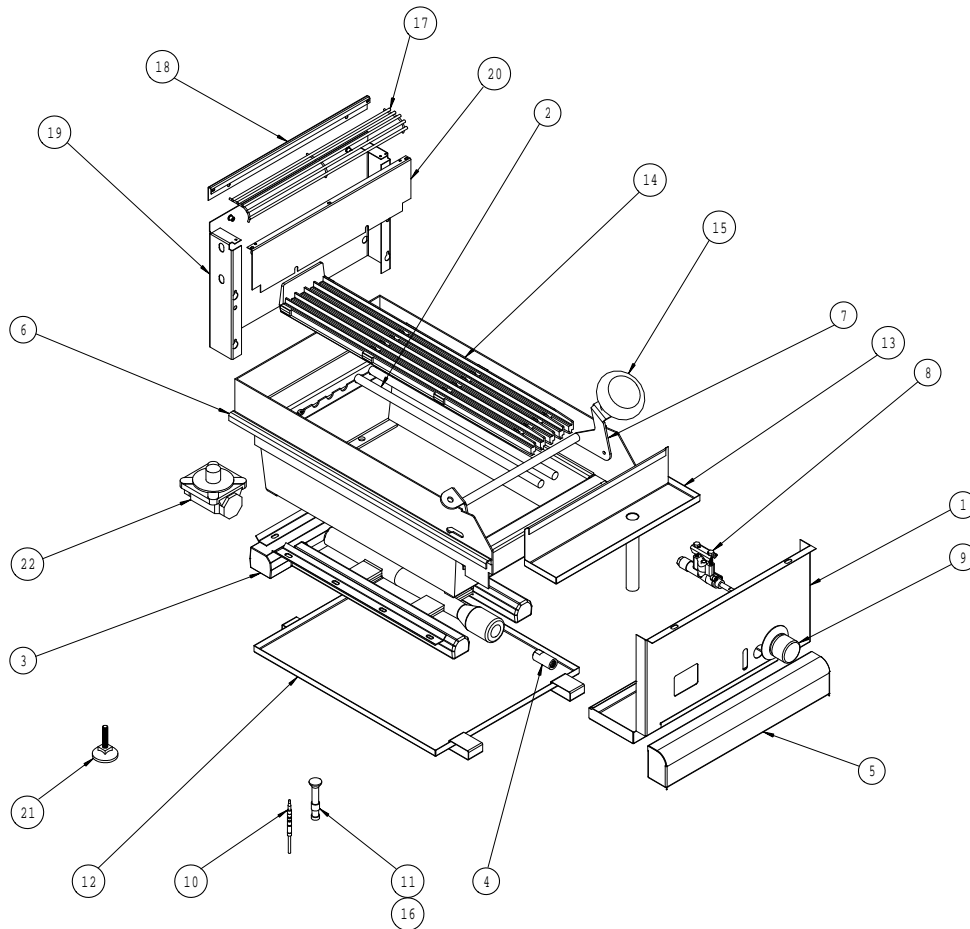
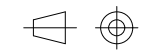

ITEM	DESCRIPTION	SPARES No	
		G350/9	G350/10
1	CONTROL PANEL	539080020	539221000
2	HEARTH ROD SET	539080030	539090030
3	BURNER ASSEMBLY	539220590	539220590
4	BURNER INJECTOR NAT GAS	539220680	539220680
	BURNER INJECTOR PROPANE	539220685	539220685
5	FAT DRAWER	539220610	539220940
6	HEARTH SURROUND	539220780	539220960
7	BRANDER LIFTING BAR	539211530	539211540
8	CONTROL VALVE NAT GAS	539220221	539220221
	CONTROL VALVE PROPANE	539220550	539220550
9	CONTROL KNOB	539220560	539220560
10	THERMOCOUPLE	539220530	539220530
11	PILOT BURNER ASSY RH NAT GAS	539220540	539220540
	PILOT BURNER ASSY RH PROPANE	539220545	539220545
	PILOT BURNER ASSY LH NAT GAS	N/A	539220910
	PILOT BURNER ASSY LH PROPANE	N/A	539220915
12	DRIP TRAY	539220600	539220930
13	DRIP TROUGH ASSEMBLY	539220615	N/A
14	BRANDING GRID	539220810	539220810
15	BRANDER KNOB	539220990	539220990
16	PILOT ORIFICE NAT GAS	539221010	539221010
	PILOT ORIFICE PROPANE	539221015	539221015
17	FLUE GRID	539211040	539210510
18	FLUE BACK TRIM	539211030	539210500
19	FLUE BACK	539211031	539220870
20	FLUE FRONT	N/A	539211090
21	ADJUSTABLE FOOT	539220730	539220730
22	GOVERNOR	539220660	539220660
23	FLUE FRONT	N/A	539211090

All dimensions in millimetres, Tolerance- Linear $\pm 0.5\text{mm}$ Angular $\pm 0.5^\circ$ (or as stated). All sharp edges to be removed from sheet metal parts.



Drawn	I. HAMILTON	Product	G350/9/10 CHARGRILLS	
Date	03-10-06	Title	SPARES DIAGRAM	
Scale				
Matl.		Drawing Number	AD45035	Issue
No. off		Finish		
Bin No.		Kraus No.		

Issue	Mod No.	Alteration	Zone	Drawn by	Date

This part is common to the following units

© No reproduction or publication of this drawing may be made and no article may be manufactured or assembled in accordance with this drawing without prior written consent. This prohibition is a condition of any contract relating to this drawing. Rights reserved under the Copyright Act 1956 as amended by the Design Copyright Act 1988.

UNCONTROLLED

Falcon Foodservice Equipment. Wallace View Hillfoots Road Stirling Scotland