DESPIECE TECNICO

**Marmitas Eléctricas
Electric Boiling Pans
Marmites Electriques
Elektro Kochkessel
Pentole Elettriche**

Gama 900

Modelos:

ME9-10 BM // ME9-15 BM

Junio 2001 June



Fagor Industrial

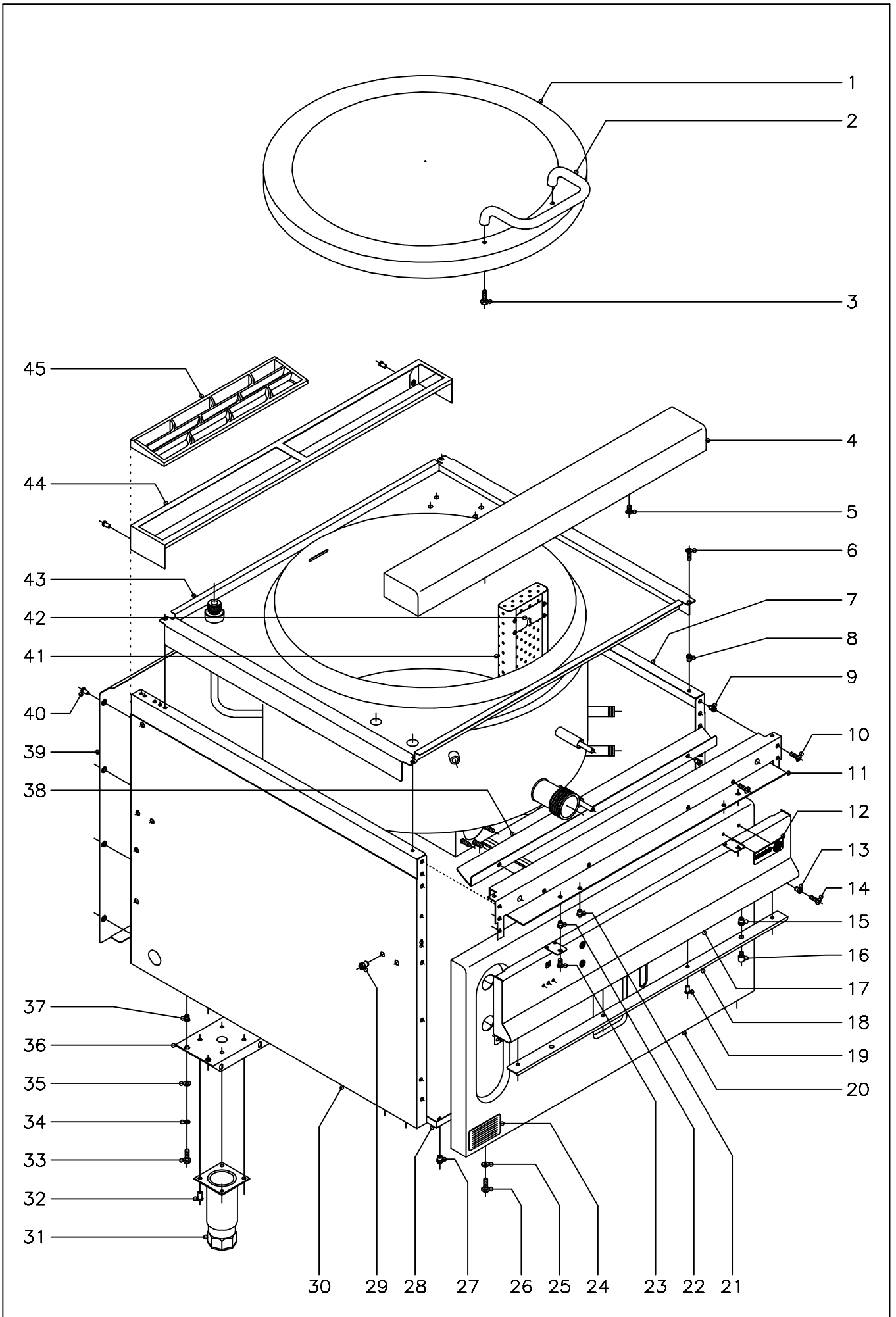



N plano	Firma	Fecha	Aparato	MUEBLE	Lamina	Fagor Industrial S.Coop. FAGOR
C-1063		6-2001	MARMITAS	ME9-10BM, ME9-15BM	1	Ofate

MOD.		MARMITAS		ZONA		MUEBLE				PLANO		C-1063	
ITEM	CODIGO	DENOMINACION	TEXTO	ME9-10 BM	ME9-15 BM	ME9-10 BM S	ME9-15 BM S						NOTAS
1	S036141	Tapa		1	1	1	1						
2	S036123	Asa de tapa		1	1	1	1						
3	Q012053	Tornillo exagonal M-8x20		2	2	2	2						
4	R165431	Anterior de mesa		1	1	1	1						
5	Q152004	Tornillo aplastado M-5x13		2	2	2	2						
6	Q152004	Tornillo aplastado M-5x13		4	4	4	4						
7	X162811	Panel lateral derecho		1	1	-	-						
7	X192805	Panel lateral derecho		-	-	1	-						
7	S372812	Panel lateral derecho		-	-	-	1						
8	Q221342	Remache exagonal M-5		4	4	4	4						
9	Q221342	Remache exagonal M-5		6	6	6	6						
10	Q152004	Tornillo aplastado M-5x13		6	6	6	6						
11	R162613	Escuadra amarre anterior mesa		1	1	1	1						
12	U262806	Escudo FAGOR		1	1	1	1						
	Q221023	Clips sujecion escudo		2	2	2	2						
13	Q221342	Remache exagonal M-5		2	2	2	2						
14	Q152004	Tornillo aplastado M-5x13		2	2	2	2						
15	Q221343	Remache exagonal M-6		1	1	1	1						
16	Q151336	Tornillo soporte guia		1	1	1	1						
17	S092809	Panel portamandos		1	1	1	1						
18	S032807	Protector		1	1	1	1						
19	Q419005	Remache tubular Ø4x8		4	4	4	4						
20	S082801	Panel frontal		1	-	-	-						
20	S092810	Panel frontal		-	1	-	1						
20	S292803	Panel frontal		-	-	1	-						
21	Q221342	Remache exagonal M-5		2	2	2	2						
22	Q221342	Remache exagonal M-5		2	2	2	2						
23	Q152004	Tornillo aplastado M-5x13		2	2	2	2						
24	S326540	Papel polyester 65x118		1	1	1	1						Placa matricula

MOD.		MARMITAS	ZONA	MUEBLE				PLANO	C-1063				
ITEM	CODIGO	DENOMINACION	TEXTO	ME9-10 BM	ME9-15 BM	ME9-10 BM S	ME9-15 BM S						NOTAS
25	Q302022	Arandela plana Ø16xØ6x1,2		2	2	2	2						
26	Q012042	Tornillo exagonal M-6x15		2	2	2	2						
27	Q221343	Remache exagonal M-6		2	2	2	2						
28	S092611	Base inferior		1	1	-	-						
28	S092806	Base inferior		-	-	1	-						
28	S362805	Base inferior		-	-	-	1						
29	Q221343	Remache exagonal M-6		14	14	14	14						
30	X162810	Panel lateral izquierdo		1	1	-	-						
30	X192803	Panel lateral izquierdo		-	-	1	-						
30	S372810	Panel lateral izquierdo		-	-	-	1						
31	X260150	Pata regulable		4	4	-	-						
32	Q411304	Remache avibulb Ø4,8		16	16	-	-						
33	Q012042	Tornillo exagonal M-6x15		8	8	-	-						
34	Q162040	Arandela muelle A-6		8	8	-	-						
35	Q302022	Arandela plana Ø16xØ6x1,2		8	8	-	-						
36	S032631	Liston soporte patas		2	2	-	-						
37	Q221343	Remache exagonal M-6		8	8	-	-						
38	S032645	Escuadra aislante calor		1	1	1	1						
	Q221342	Remache exagonal M-5		2	2	2	2						
	Q152004	Tornillo aplastado M-5x13		2	2	2	2						
39	U562853	Panel posterior		1	1	-	-						
39	X242817	Panel posterior		-	-	1	-						
39	S372816	Panel posterior		-	-	-	1						
40	Q419005	Remache tubular Ø4x8		8	8	8	8						
41	S016145	Filtro de cuba		1	-	1	-						
41	S036145	Filtro de cuba		-	1	-	1						
42	S036117	Soporte filtro		2	2	2	2						
	Q412000	Remache tubular Ø4x8		8	8	8	8						
43	S086150	Cuba de 100 l.		1	-	1	-						

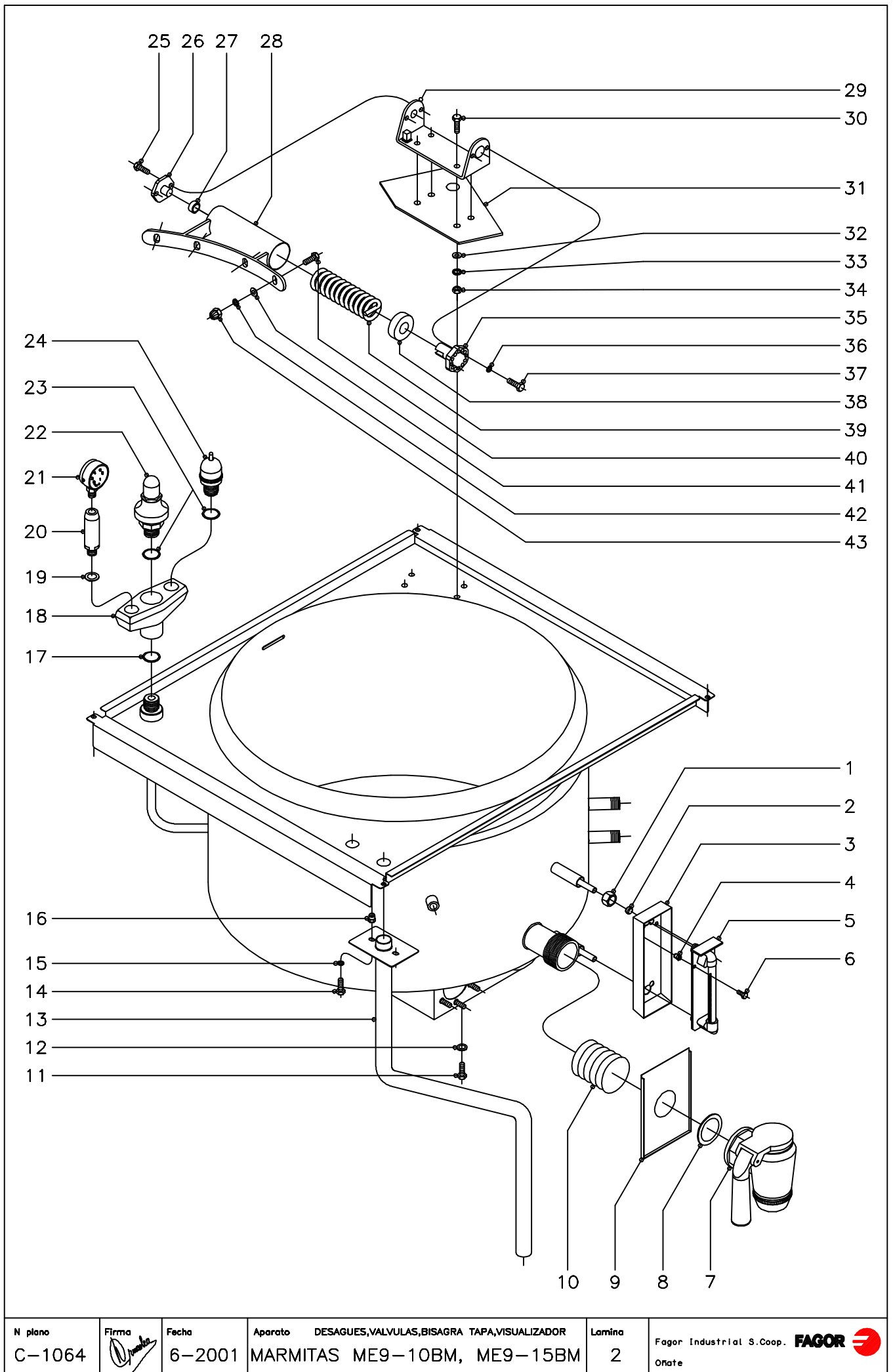
ITEM	CODIGO	DENOMINACION	TEXTO	ME9-10 BM	ME9-15 BM	ME9-10 BM S	ME9-15 BM S						NOTAS
43	S096150	Cuba de 150 l.		-	1	-	1						
44	R205428	Soporte embellecedor 1 M.		1	1	1	1						
	Q419005	Remache tubular Ø4x8		2	2	2	2						
45	R205425	Embellecedor chimenea		2	2	2	2						



N plano C-1064	Firma 	Fecha 6-2001	Aparato DESAGUES, VALVULAS, BISAGRA TAPA, VISUALIZADOR MARMITAS ME9-10BM, ME9-15BM	Lamina 2	Fagor Industrial S.Coop. FAGOR  Oñate
-------------------	--	-----------------	---	-------------	--

MOD.		MARMITAS		ZONA		DESAGUES, VALVULAS, BISAGRA TAPA, VISUALIZADOR				PLANO		C-1064	
ITEM	CODIGO	DENOMINACION	TEXTO	ME9-10 BM	ME9-15 BM	ME9-10 BM S	ME9-15 BM S						NOTAS
1	S082101	Tuerca 3/8"		2	2	2	2						
2	U265008	Bicono Ø 10		2	2	2	2						
3	S292600	Proteccion visualizador		1	1	1	1						
4	Q221341	Remache exagonal M-4		2	2	2	2						
5	S082100	Visualizador		1	1	1	1						
6	Q012021	Tornillo exagonal M-4x10		2	2	2	2						
7	S112150	Grifo de vaciado		1	1	1	1						
8	S112152	Junta grifo vaciado		1	1	1	1						
9	S112803	Cubierta de grifo		1	1	1	1						
10	S112105	Muelle soporte cubierta		1	1	1	1						
11	Q012063	Tornillo exagonal M-10x20		1	1	1	1						
12	Q304003	Arandela junta cobre Ø18xØ10,5x2		1	1	1	1						
13	S036119	Tubo vaciado		1	1	-	1						
13	S065004	Tubo vaciado		-	-	1	-						
14	Q012032	Tornillo exagonal M-5x15		2	2	2	2						
15	Q262030	Arandela muelle A-5		2	2	2	2						
16	Q221342	Remache exagonal M-5		2	2	2	2						
17	Q306049	Arandela junta Ø31xØ26,5x1		1	1	1	1						
18	S022100	Soporte tres salidas		1	1	1	1						
19	Q306039	Arandela junta Ø25xØ16,5x1,5		1	1	1	1						
20	S022102	Sifon portamanometro		1	1	1	1						
21	9220815	Manometro de 0 a 1 kg/cm2		1	1	1	1						
22	S022101	Valvula de seguridad		1	1	1	1						
23	Q306049	Arandela junta Ø31xØ26,5x1		2	2	2	2						
24	S022103	Valvula de presion		1	1	1	1						
25	Q012041	Tornillo exgonal M-6x10		2	2	2	2						
26	S116119	Giro de asa		1	1	1	1						
27	S116126	Cojinete cilindrico		1	1	1	1						
28	S036143	Bisagra tapa		1	1	1	1						

MOD.		MARMITAS		ZONA		DESAGUES, VALVULAS, BISAGRA TAPA, VISUALIZADOR				PLANO		C-1064	
ITEM	CODIGO	DENOMINACION	TEXTO	ME9-10 BM	ME9-15 BM	ME9-10 BM S	ME9-15 BM S						NOTAS
29	S036131	Soporte de bisagra		1	1	1	1						
30	Q012055	Tornillo exagonal M-8x30		4	4	4	4						
31	S026102	Refuerzo bisagra		1	1	1	1						
32	Q232050	Arandela plana A-8		4	4	4	4						
33	Q262050	Arandela muelle A-8		4	4	4	4						
34	Q162050	Tuerca exagonal M-8		4	4	4	4						
35	S116120	Tensor resorte		1	1	1	1						
36	Q262040	Arandela muelle A-6		2	2	2	2						
37	Q012042	Tornillo exagonal M-6x15		2	2	2	2						
38	S116118	Casquillo		1	1	1	1						
39	S116121	Resorte tapa		1	1	1	1						
40	Q012053	Tornillo exagonal M-8x20		4	4	4	4						
41	Q232050	Arandela plana A-8		4	4	4	4						
42	Q262050	Arandela muelle A-8		4	4	4	4						
43	Q212051	Tuerca sombrerete M-8		4	4	4	4						

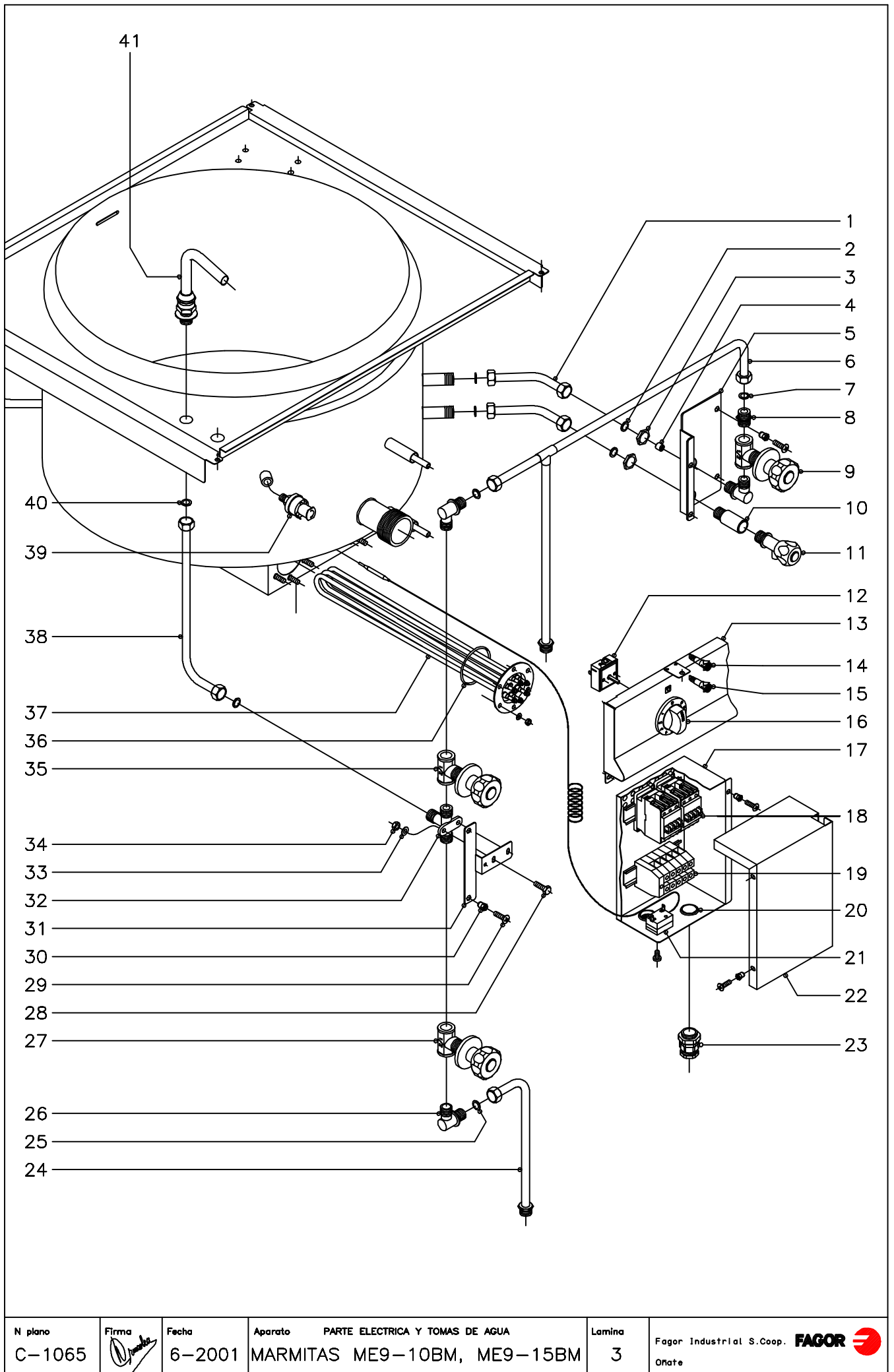

N plano
C-1065

Firma
[Signature]

Fecha
6-2001

Aparato PARTE ELECTRICA Y TOMAS DE AGUA
MARMITAS ME9-10BM, ME9-15BM

Lamina
3

Fagor Industrial S.Coop. **FAGOR**
Oñate

MOD.		MARMITAS		ZONA		PARTE ELECTRICA Y TOMAS DE AGUA				PLANO		C-1065	
ITEM	CODIGO	DENOMINACION	TEXTO	ME9-10 BM	ME9-15 BM	ME9-10 BM S	ME9-15 BM S						NOTAS
1	S025006	Conduccion a nivel y llenado		2	-	2	-						
1	S045004	Conduccion a nivel y llenado		-	2	-	2						
2	Q306024	Arandela junta Ø 18xØ 12,5x1,5		4	4	4	4						
3	Q221302	Tuerca exagonal 1/2"		2	2	2	2						
4	S225012	Regulador de caudal		1	1	1	1						
5	S092601	Soporte grifos llenado-vaciado		1	1	1	1						
	Q221342	Remache exagonal M-5		2	2	2	2						
	Q152004	Tornillo aplastado M-5x13		2	2	2	2						
6	S045015	Conduccion superior agua (calien.)		1	1	-	-						
6	S065018	Conduccion superior agua (calien.)		-	-	1	-						
6	S375005	Conduccion superior agua (calien.)		-	-	-	1						
7	Q306024	Arandela junta Ø 18xØ 12,5x1,5		2	2	2	2						
8	S205023	Manguito doble 1/2"		1	1	1	1						
9	S112154	Llave de paso c/mando (Caliente)		1	1	1	1						
10	S045006	Casquillo grifo nivel		1	1	1	1						
11	S022104	Grifo nivel		1	1	1	1						
12	S333001	Regulador de energia		1	1	1	1						
13	S092809	Panel portamandos		1	1	1	1						
14	Z203004	Piloto verde		1	1	1	1						
15	Z203005	Piloto ambar		1	1	1	1						
16	S333006	Boton de mando Ø 6		1	1	1	1						
17	S092604	Caja electrica		1	1	1	1						
	Q221342	Remache exagonal M-5		2	2	2	2						
	Q152004	Tornillo aplastado M-5x13		2	2	2	2						
18	X183011	Contactador 230V.		2	2	2	2						
	Z103084	Guia L=138		1	1	1	1						
19	Z683069	Borna fases (gris)		3	3	3	3						
	Z683097	Borna neutro (azul)		1	1	1	1						
	Z683070	Borna tierra (verde-amarillo)		1	1	1	1						

MOD.		MARMITAS		ZONA		PARTE ELECTRICA Y TOMAS DE AGUA				PLANO		C-1065	
ITEM	CODIGO	DENOMINACION	TEXTO	ME9-10 BM	ME9-15 BM	ME9-10 BM S	ME9-15 BM S						NOTAS
	Z683096	Tope final		1	1	1	1						
	Z103084	Guia L=138		1	1	1	1						
20	X723014	Pasamuros Ø 30		2	2	2	2						
21	Z213014	Termostato limitador		1	1	1	1						
	Q081330	Tornillo alomado BZ-3,5x6,5		2	2	2	2						
22	S093014	Tapa caja electrica		1	1	1	1						
	Q221342	Remache exagonal M-5		3	3	3	3						
	Q152004	Tornillo aplastado M-5x13		3	3	3	3						
23	R023013	Prensaestopas		1	1	1	1						
24	S035036	Conduccion inferior agua (fria)		1	1	-	-						
24	S065020	Conduccion inferior agua (fria)		-	-	1	-						
24	S375007	Conduccion inferior agua (fria)		-	-	-	1						
25	Q306024	Arandela junta Ø 18xØ 12,5x1,5		1	1	1	1						
26	S115013	Codo		3	3	3	3						
27	S112151	Llave paso con mando (fria)		1	1	1	1						
28	Q012042	Tornillo exagonal M-6x15		2	2	2	2						
29	Q152004	Tornillo aplastado M-5x13		2	2	2	2						
30	Q221342	Remache exagonal M-5		2	2	2	2						
31	S032640	Soporte grifos de agua		1	1	1	1						
32	S205022	Racord union de grifos		1	1	1	1						
33	Q262040	Arandela muelle A-6		2	2	2	2						
34	Q162040	Tuerca exagonal M-6		2	2	2	2						
35	S112154	Llave de paso c/mando (Caliente)		1	1	1	1						
36	Q307035	Junta torica AN-36		2	2	2	2						
37	Z721701	Resistencia calenta. 9600W.,230V.		2	2	2	2						
	Q232040	Arandela plana A-6		12	12	12	12						
	Q163140	Tuerca exagonal M-6		12	12	12	12						
38	S035032	Conducto grifos a base		1	1	1	1						
39	S093000	Presostato		1	1	1	1						

MOD.

MARMITAS

ZONA

PARTE ELECTRICA Y TOMAS DE AGUA

PLANO

C-1065

ITEM	CODIGO	DENOMINACION	TEXTO	ME9-10 BM	ME9-15 BM	ME9-10 BM S	ME9-15 BM S							NOTAS
40	Q306024	Arandela junta \varnothing 18x \varnothing 12,5x1,5		2	2	2	2							
41	S052100	Tubo de llenado		1	1	1	1							

MOD.	MARMITAS			ZONA	VARIOS				PLANO				
ITEM	CODIGO	DENOMINACION	TEXTO	ME9-10 BM	ME9-15 BM	ME9-10 BM S	ME9-15 BM S						NOTAS
	S096511	Folleto de instrucciones		1	1	1	1						
	S333003	Esquema electrico adhesivo		1	1	1	1						Plano HC-72844
	S333002	Esquema electrico de montaje		1	1	1	1						Plano HC-72843
	S093002	Cableado portamandos		1	1	1	1						
	X183008	Cableado regleta a contactor		2	2	2	2						
	S093004	Cableado contactor a resistencias		1	1	1	1						

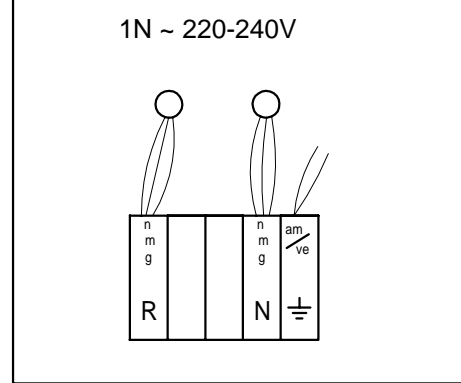
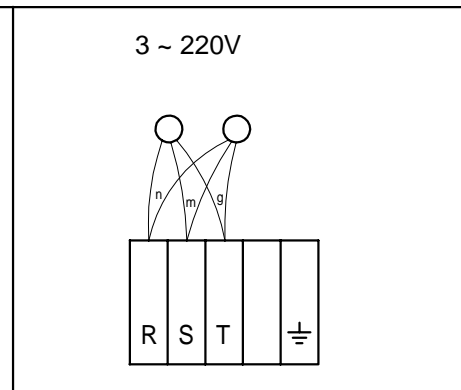
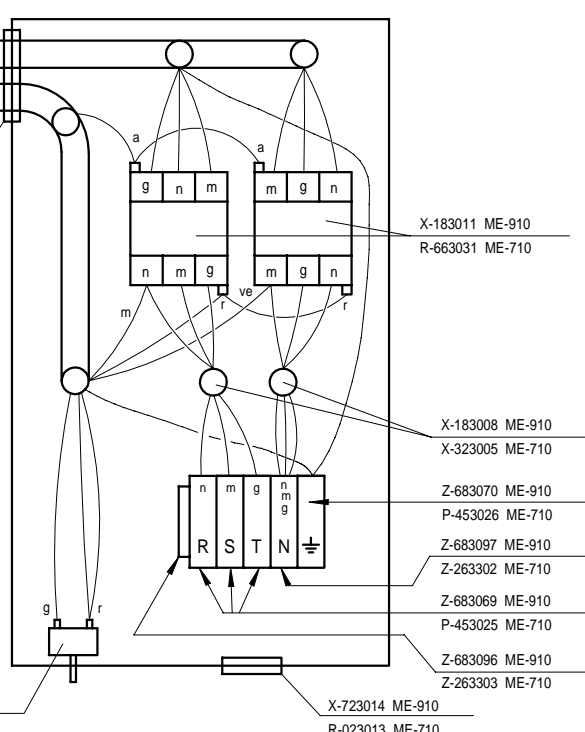
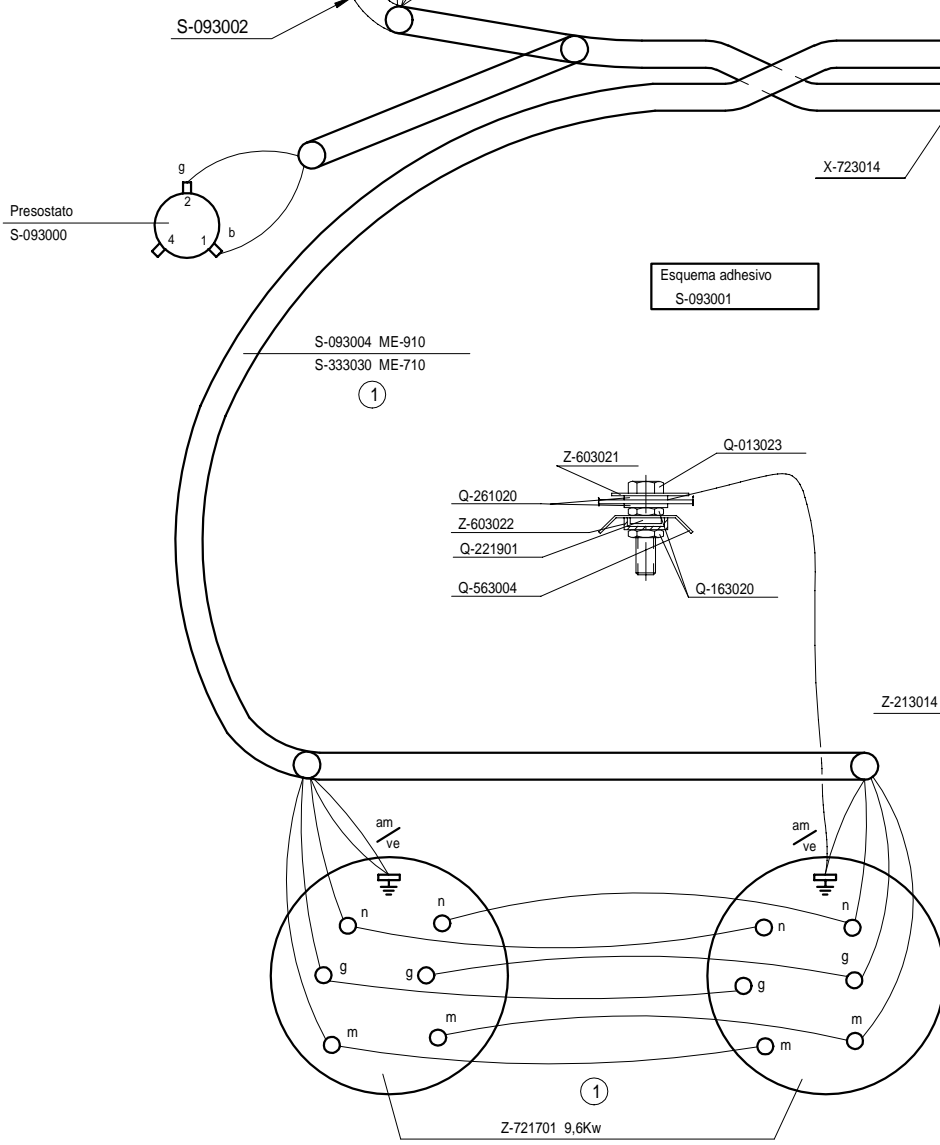
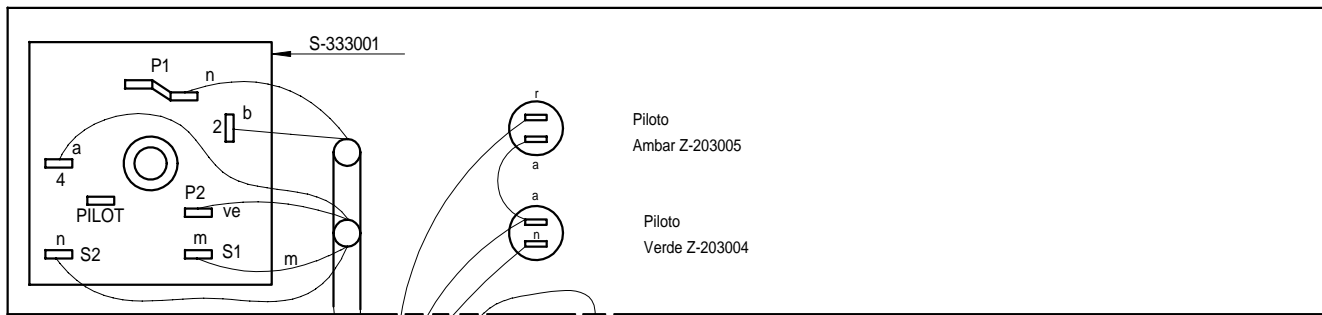

Plano de montaje 380-415V		S-333002	
Nº	Pieza	Cant.	Material
Nº	Modificación	Propuesta de	Fecha
1	De R143000 a Z721701 en ME710	Plazaola	9-2-99
DeS333000aS333030/deZ691751aZ721701			
Tolerancias generales		$\leq 3\pm$ $5-25\pm$ $25-50\pm$	
		$50-100\pm$ $> 100\pm$ $\infty\pm$	
Dibujado	Firma	Fecha	
Proyectado	KONTXI	19/6/97	
Comprobado	<i>foya</i>		
Escala	Fagor Industrial, Koop, Elk, Mugatua		Mecanizado superficial
<p style="text-align: center;">MARMITAS</p>			Plano numero
			HC-72843-1
Plano hau ez daiteke erabili ez berrizta gure baimenitz gabe			Sustituye al N°
			Sustituido por

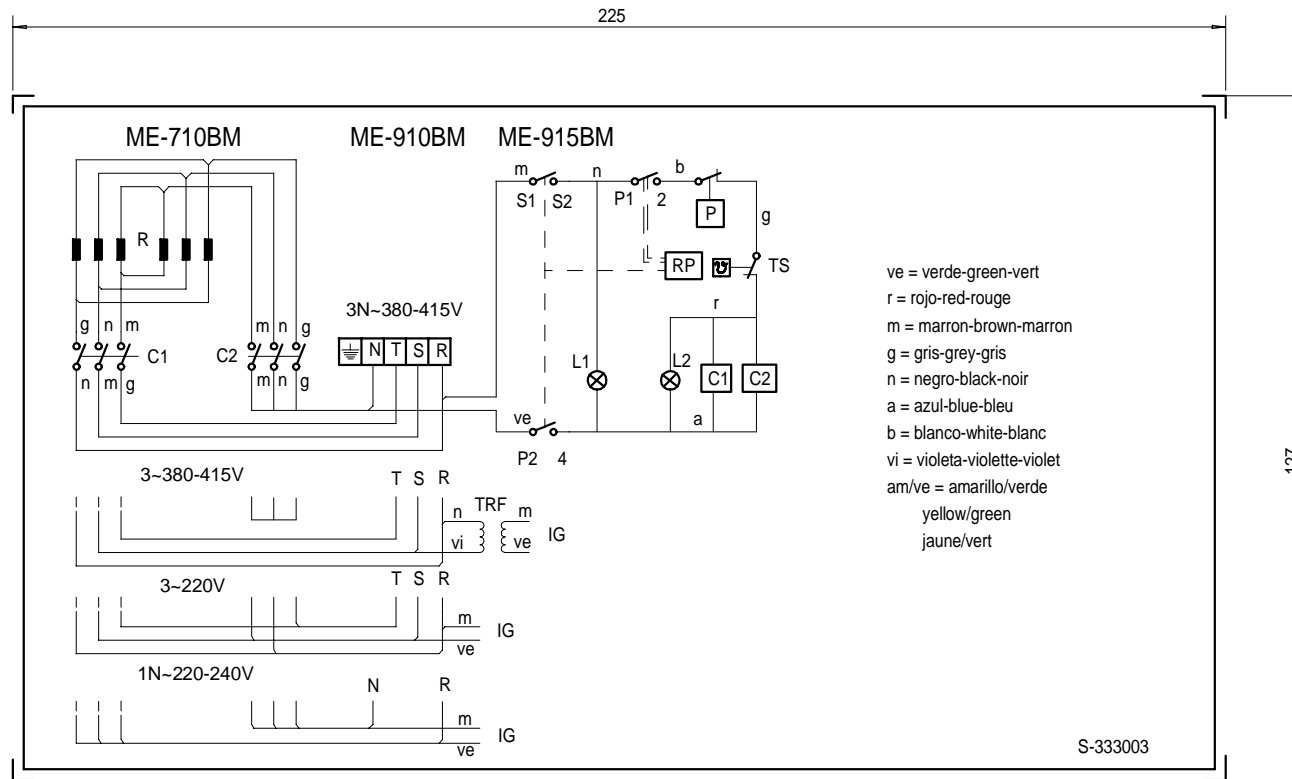

NOTA

- Las inscripciones resistirán sin modificación apreciable el frotamiento durante 15 seg. de un algodón impregnado en gasolina.

- IG: Interruptor general
- L1: Lámpara funcionamiento
- RP: Regulador de energía.
- L2: Lámpara calentamiento
- C1,C2: Contactor de calentamiento
- R: Resistencias
- P: Presostato (0,3 bar.)
- TS: Termostato Seguridad (125°)
- TRF: Transformador

Plastico blanco alto brillo

Esquema teorico adhesivo		S-333003			
Nº	Pieza	Material	Nº Clasificacion	Acabado	
Nº	Modificacion	Propuesta de	Fecha	Tolerancias generales	
				$\leq 5 \pm$ $5-25 \pm$ $25-50 \pm$	$50-100 \pm$ $> 100 \pm$ $\infty \pm$
	Firma	Fecha	 Fagor Industrial, Koop, Elk, Mugatua		
Dibujado	KONTXI	20/6/97			
Proyectado					
Comprobado	<i>Letour</i>				
Escala	MARMITA ELECTRICA			Plano numero	
				HC-72844	
				Sustituye al Nº	
	Plano hau ez daiteke erabili ez bertizia gure baimeniz gabe			Sustituido por	