DESPIECE TECNICO

**Mantenedor de fritos
Chips scuttle
Chauffe frites
Frittenwanne
Scaldapatate
Conservador de frituras**

GAMA SNACK

Modelos:

MF6-05

Junio 2009 June

Revisado Mayo 2013 May Revised



F A G O R I N D U S T R I A L

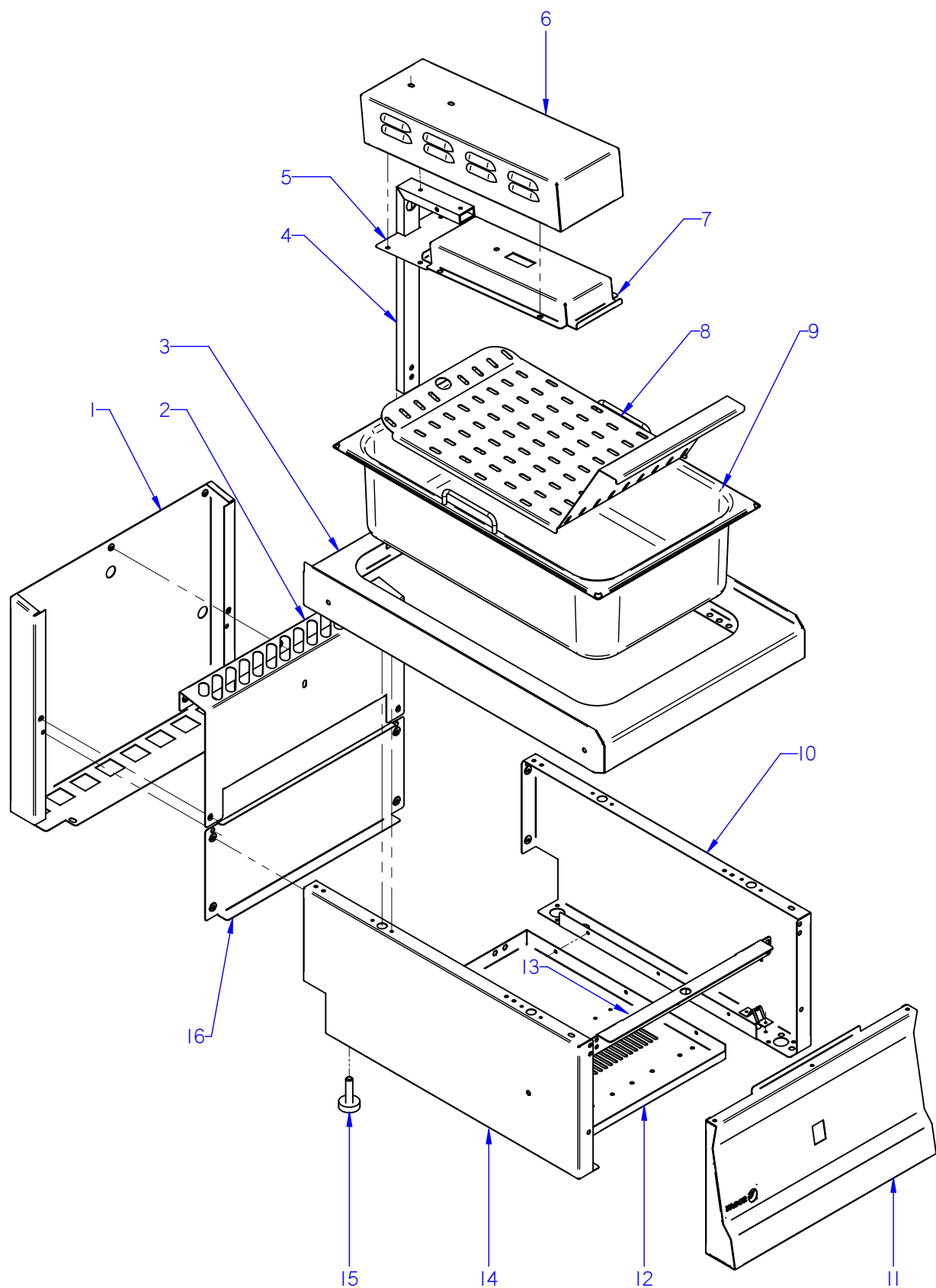

ITEM MARCADO EN COLOR = REPUESTO RECOMENDADO
 COLOURED ITEM = RECOMMENDED SPARE PART

N plano	Firma	Fecha	Aparato	MUEBLE	Lamina	Fagor Industrial S.Coop. FAGOR
C-2399	<i>(Signature)</i>	2009-06	MANTENEDOR DE FRITOS MF6-05		1	Oñate

MOD.		MANTENEDOR DE FRITOS CHIPS SCUTTLE		ZONA	MUEBLE / UNIT					PLANO	C-2399
ITEM	CODIGO	DENOMINACION	TEXTO	MF6-05							NOTAS
1	J142809000	PROTECCION CHIMENEA POS. 400	PROTECTION CHIMEMEY POS.	1							ELIMINADA 28.11.11
1	J142815000	PROTECTOR CHIMENEA FRYES 400	PROTECTION CHIMEMEY FRY.	1							INTRODUC. 28.11.11
	Q419005000	REMACHE 4X8 ALMG3 / ALUMINIO	RIVET 4X8 ALMG3 / ALUMINIUM	2							
2	J272806000	PROTECCION CHIMENEA MF6-05	PROTECT. CHIMENEA MF6-05	1							
	Q012031000	TORNILLO EXAGONAL M5x10 A304	HEXAGONAL BOLT M5x10 A304	4							
	Q302022000	ARANDELA 16x6x1,2 A304	WASHER 16x6x1.2 A304	4							
	Q221342000	REMACHE EXAGONAL M5	HEXAGONAL RIVET M5	3							
3	J275417000	ENCIMERA MF6-05	TOP MF6-05	1							
	Q221342000	REMACHE EXAGONAL M5	HEXAGONAL RIVET M5	4							
	X012612000	PITON CIERRE	LOCK SPIKE	4							ELIMINADA 01.04.2010
	Z442919000	PITON CIERRE	LOCK SPIKE	4							INTRODUC. 01.04.2010
	Q221342000	REMACHE EXAGONAL M5	HEXAGONAL RIVET M5	2							
4	J275418000	POSTE COMPL.CHIPS SCUTTLE	COMPL. COLUMN CHIPS SCUTTLE	1							
5	J272602000	CUBIERTA DE CAJA	COVER OF BOX	1							
	Q152004000	TORNIL. APLASTADO M5X13 A 304	FLAT HEADED SCREW M5x13 A 304	4							
6	J275406000	TAPA PROTECCIÓN	PROTECTION CAP	1							
	Q221342000	REMACHE EXAGONAL M5	HEXAGONAL RIVET M5	4							
7	J272601000	CAJA DE RESISTENCIAS	BOX OF RESISTENCES	1							
	Q221342000	REMACHE EXAGONAL M5	HEXAGONAL RIVET M5	4							
	Q152004000	TORNIL. APLASTADO M5X13 A 304	FLAT HEADED SCREW M5x13 A 304	4							
8	J272805000	PANEL SEPARADOR	PANEL SEPARATOR	1							
9	J275415000	FUENTE 1/1 CON ASA	DISH 1/1 WITH HANDLE	1							
10	J002802000	PANEL LATERAL DERECHO	RIGHT SIDE PANEL	1							ELIMINADA 01.04.2010
10	J002834000	PANEL LATERAL DERECHO	RIGHT SIDE PANEL	1							INTRODUC. 01.04.2010
	Q221342000	REMACHE EXAGONAL M5	HEXAGONAL RIVET M5	1							
	Q419007000	REMACHE TUBULAR C/V D3.2X6	TUBULAR RIVET C/V D3.2X6	8							
	X010503000	CIERRE MUELLE	LOCK SPRING	4							ELIMINADA 01.04.2010
	Z442918000	CLIP CIERRE	LOCK SPRING	4							INTRODUC. 01.04.2010

MOD.		MANTENEDOR DE FRITOS CHIPS SCUTTLE		ZONA	MUEBLE / UNIT						PLANO	C-2399
ITEM	CODIGO	DENOMINACION	TEXTO	MF6-05							NOTAS	
11	J272802000	PORTAMANDOS MF6-05	CONTROL HOLDER MF6-05	1								
	U022836000	ESCUDO FAGOR	FAGOR EMBLEM	1								
	Q221023000	CLIP SUJECIÓN RÁPIDA Ø5	RAPID CONNECT CLIP Ø5	2								
	Q419005000	REMACHE 4x8 ALMG3 / ALUMINIO	RIVET 4X8 ALMG3 / ALUMINIUM	6								
	Q012031000	TORNILLO EXAGONAL M5x10 A304	HEXAGONAL BOLT M5x10 A304	2								
	Q302022000	ARANDELA 16x6x1,2 A304	WASHER 16x6x1.2 A304	2								
12	J002604000	BASE INFERIOR 400	LOWER BASE 400	1								
	Q419005000	REMACHE 4X8 ALMG3 / ALUMINIO	RIVET 4X8 ALMG3 / ALUMINIUM	6								
13	J002610000	GUÍA PANEL PORTAMANDOS 400	GUIDE PANEL OF CONTROLS	1								
	Q221342000	REMACHE EXAGONAL M5	HEXAGONAL RIVET M5	4								
	Q012031000	TORNILLO EXAGONAL M5x10 A304	HEXAGONAL BOLT M5x10 A304	4								
14	J002801000	PANEL LATERAL IZQUIERDO	LEFT SIDE PANEL	1							ELIMINADA 01.04.2010	
14	J002833000	PANEL LATERAL IZQUIERDO	LEFT SIDE PANEL	1							INTRODUC. 01.04.2010	
	Q221342000	REMACHE EXAGONAL M5	HEXAGONAL RIVET M5	1								
	Q419007000	REMACHE TUBULAR C/V D3.2X6	TUBULAR RIVET C/V D3.2X6	8								
	X010503000	CIERRE MUELLE	LOCK SPRING	4							ELIMINADA 01.04.2010	
	Z442918000	CLIP CIERRE	LOCK SPRING	4							INTRODUC. 01.04.2010	
15	Z200107000	PATA REGULABLE	ADJUSTABLE LEG	4								
16	J002803000	PANEL POSTERIOR 400	REAR PANEL 400	1								
	Q419005000	REMACHE 4x8 ALMG3 / ALUMINIO	RIVET 4X8 ALMG3 / ALUMINIUM	4								

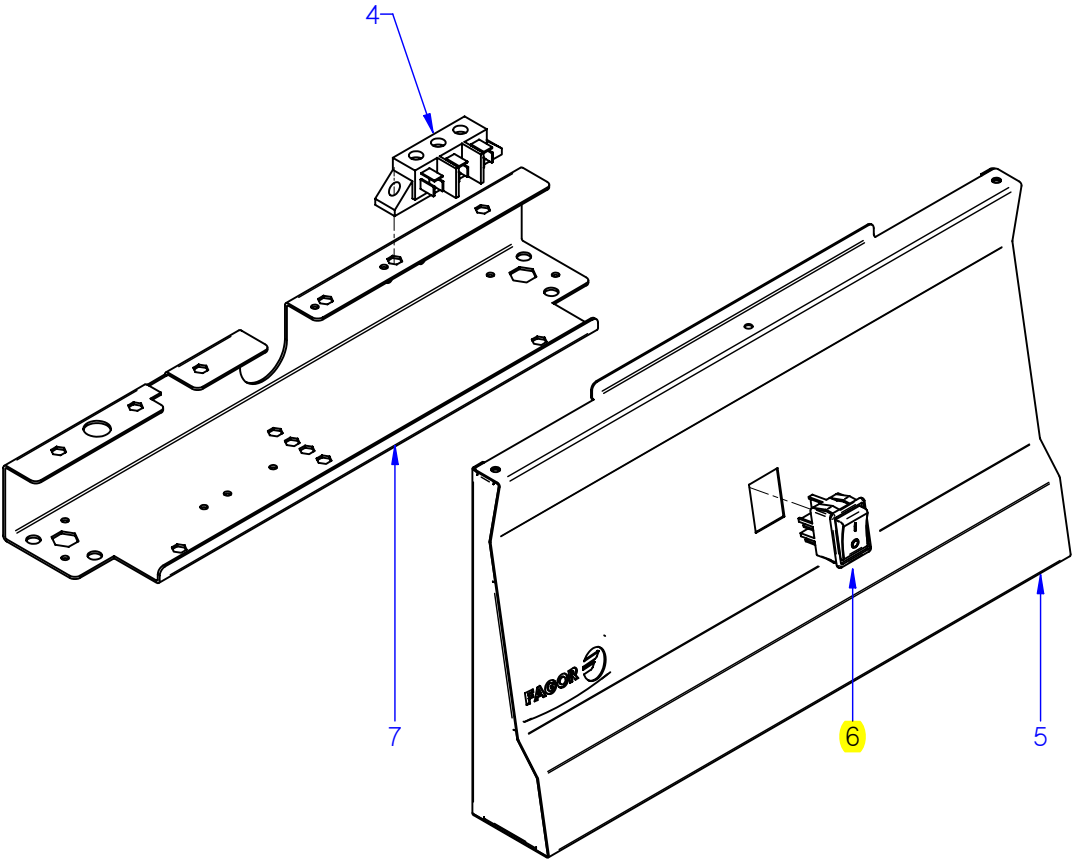
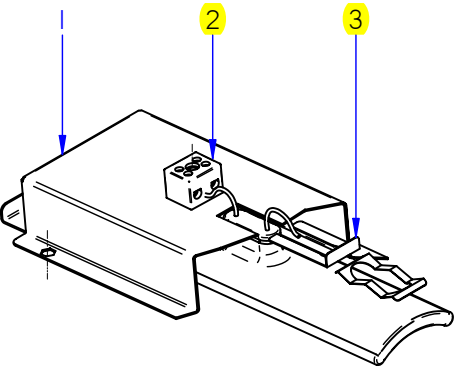

ITEM MARCADO EN COLOR = REPUESTO RECOMENDADO
COLOURED ITEM = RECOMMENDED SPARE PART

N plano	Firma	Fecha	Aparato	Lamina	Fagor Industrial S. Coop. Omate
C-2400		2009-06	MANTENEDOR DE FRITOS MF6-05	2	
CONJUNTO FUNCIONAL					

MOD.	MANTENEDOR DE FRITOS CHIPS SCUTTLE	ZONA	CONJUNTO FUNCIONAL / FUNCTIONAL UNIT	PLANO	C-2400
------	---	------	---	-------	---------------

ITEM	CODIGO	DENOMINACION	TEXTO	MF6-05							NOTAS
1	J272601000	CAJA DE RESISTENCIAS	BOX OF RESISTENCES	1							
	Q221342000	REMACHE EXAGONAL M5	HEXAGONAL RIVET M5	4							
	Q152004000	TORNIL. APLASTADO M5X13 A 304	FLAT HEADED SCREW M5x13 A 3	4							
2	J272101000	REGLETA CERAMICA CP6-05	CERAMIC TERMINAL STRIP	1							
3	J273001000	RESISTENCIA INFRARROJOS	RESISTANCE INFRARED	1							
4	U183046000	REGLETA AUXILIAR	AUXILIARY TERMINAL	1							
	Q152004000	TORNIL. APLASTADO M5X13 A 304	FLAT HEADED SCREW M5x13 A 3	2							
5	J272802000	PORTAMANDOS MF6-05	CONTROL HOLDER MF6-05	1							
6	Z203033000	INTERRUPTOR GENERAL	POWER SWITCH	1							
7	J002602000	FRONTAL SUPERIOR 400	FRONT SUPPORT 400	1							

MOD. MANTENEDOR DE FRITOS CHIPS SCUTTLE ZONA VARIOS / MISCELLANEOUS PLANO 											
ITEM	CODIGO	DENOMINACION	TEXTO	MF6-05							NOTAS
	J276501000	FOLLETO DE INSTRUC. MF6-05	INSTRUC. LEAFLET MF6-05	1							
	J273002000	ESQUEMA TEORICO MF6-05	THEOR. DIAGRAM MF6-05	1							PLANO HB-80537
	J273003000	ESQUEMA MONTAJE	ASSEMBLY DIAGRAM	1							PLANO HB-80539
	J273004000	INSTALAC. ELECTRICA CP6-05	ELECTR. INSTALLATION CP6-05	1							

MOD.	MANTENEDOR DE FRITOS SCUTTLE	CHIPS	ZONA	REPUESTOS RECOMENDADOS RECOMMENDED SPARE PART	PLANO	
------	---------------------------------	-------	------	--	-------	--

ITEM	CODIGO	DENOMINACION	TEXTO	MF6-05							NOTAS
2	J272101000	REGLETA CERAMICA CP6-05	CERAMIC TERMINAL STRIP	1							C-2400
3	J273001000	RESISTENCIA INFRARROJOS	RESISTANCE INFRARED	1							C-2400
6	Z203033000	INTERRUPTOR GENERAL	POWER SWITCH	1							C-2400

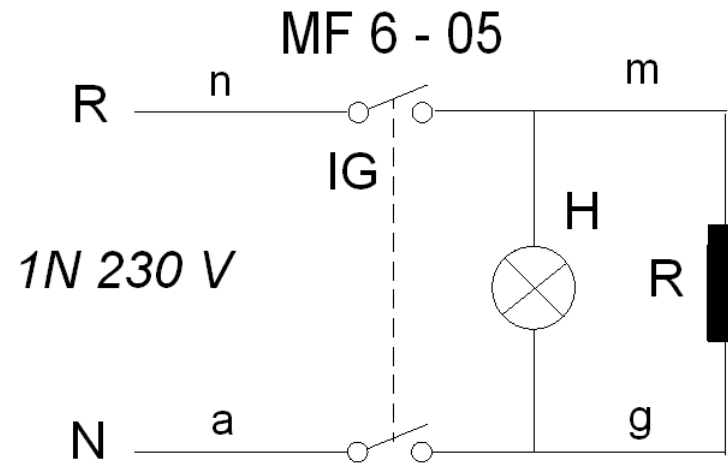

a = azul-blue m = marron - brown g = gris - grey n = negro-black

IG: Interruptor general/Main switch

H: Piloto encendido / Operation light

R: Resistencia/Resistance

J273002000

- Theoretical diagram: MF		-		J273002000	-
Zk./N°	Pieza	Cant.	Materiala/Material	Klas. zk./N° Clas.	Gainazal akabera/Tratamiento
Zk./N°	Aldaketa/Modificaciones		Nork. proposatua/Propuesta de	Data/Fecha	Perdoi orokorrak Tolerancias generales
-	-		-	-	
-	-		-	-	< 5 ± 0.2 50 - 100 ± 0.8
-	-		-	-	5 - 25 ± 0.4 > 100 ± 1
-	-		-	-	25 - 50 ± 0.6 ϕ ± 1
		Sinadura/Firma	Data/Fecha	Gainazal perdoia Mecanizado superficial	
Marratzua/Dibujado		e.carrascal	2008-11-12	 Fagor Industrial, Koop. Elk., Mugatua	
Proiektatua/Proyectado		e.carrascal	2008-11-12		
Egiaztatua/Comprobado		<i>J. Alberdi</i>	2008-11-12		
Eskala/Escala		COOKING			Plano Zk./Plano N° HB-80537
-		Plano hau ezin daiteke erabili, ez berrizatu, gure baimenik gabe.			- Zk. ord. du
					- Zk.gaitik ord.

MF 605

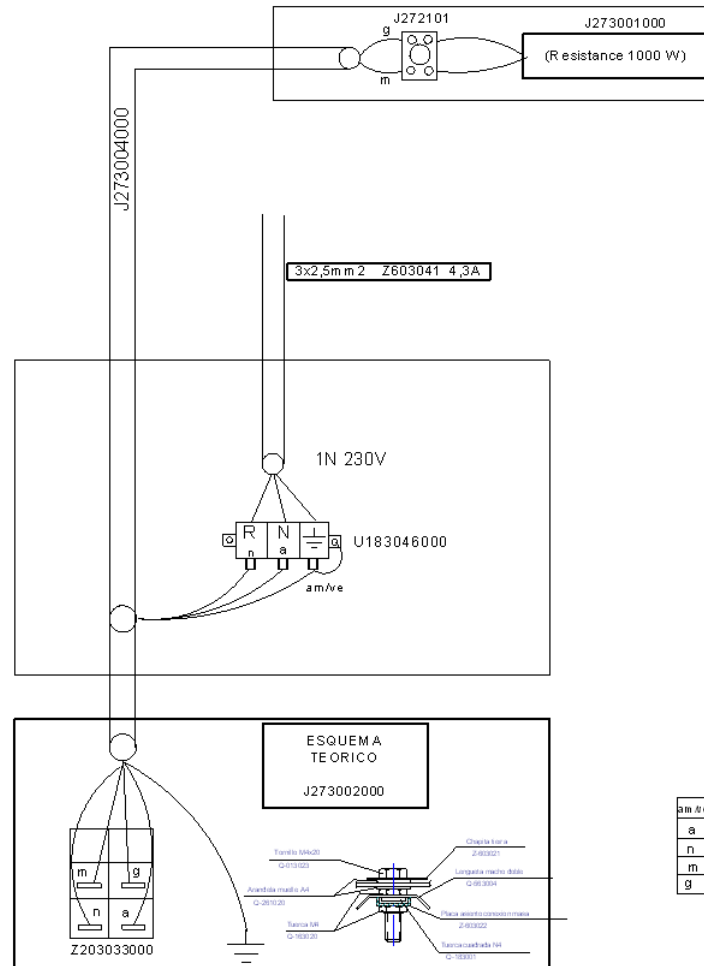

COLORS		
am/te	amarillo/verde	yellow/green
a	azul	blue
n	negro	black
m	marron	brown
g	gris	grey

- PLANO MONTAJE MF 605		- J273003000	
Zk./N°	Pieza	Cant.	Materia/Material
Zk./N°	Aldaketa/Modificaciones		Nork proposatua/Propuesta de
-	-	-	-
-	-	-	-
-	-	-	-
-	-	-	-
-	-	-	-
Sinadura/Firma			Data/Fecha
Marratzua/Dibujado	M.Maillo	2009-05-12	 Fagor Industrial, Koop. Elk., Mugatua
Proiektatua/Proyectado	M.Maillo	2009-05-12	
Egiaztatua/Comprobado	<i>i. Alberdi</i>	2009-05-12	
Eskala/Escala			
Gainazal akabera/Tratamiento			Gainazal perdoia
Tolerancias generales			Mecanizado superficial
$< 5 \pm 0.2$			$50 - 100 \pm 0.8$
$5 + 25 \pm 0.4$			$> 100 \pm 1$
$25 + 50 \pm 0.6$			$\alpha \pm 1^\circ$
Plano Zk./Plano N°			HB-80539
-			Zk. ord. du
-			Zk. gaitik ord.

CHIPS SCUTTLE

Plano hau ezin daiteke erabili, ez berrizatu, gure baimenik gabe.