

NM952 SERVICE PARTS

This parts list contains the service parts and wiring diagrams for this model. Check the model number in question to be sure that it is applicable to this parts list.

TABLE OF CONTENTS

Cabinet	2
Air Cooled Refrigeration.....	3
Water Cooled Refrigeration.....	4
Water System.....	5
Gearmotor.....	6
Evaporator	7
Control Box.....	8
Wiring Diagrams.....	9

NM952 SERVICE PARTS

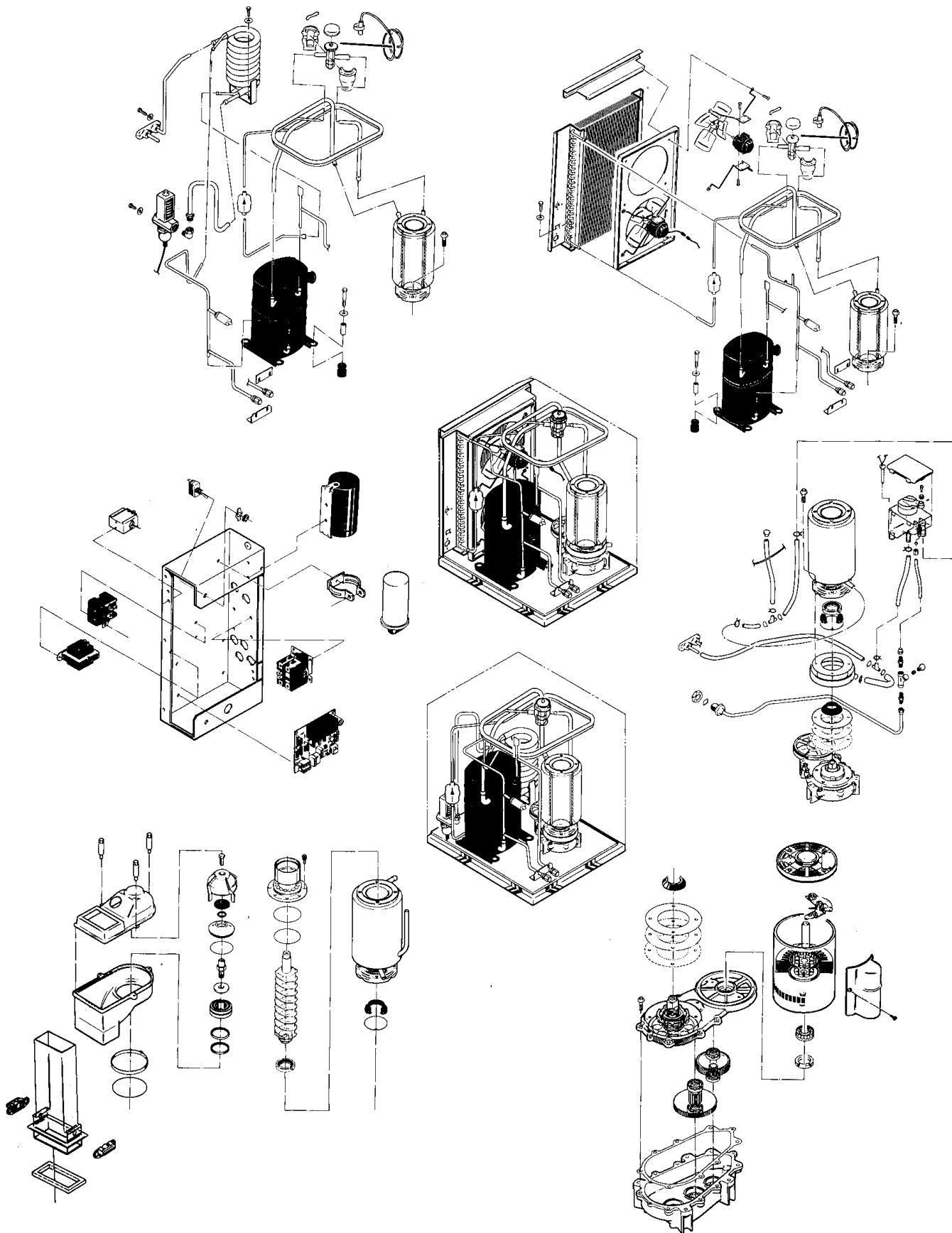

NM952 SERVICE PARTS

Cabinet Assembly

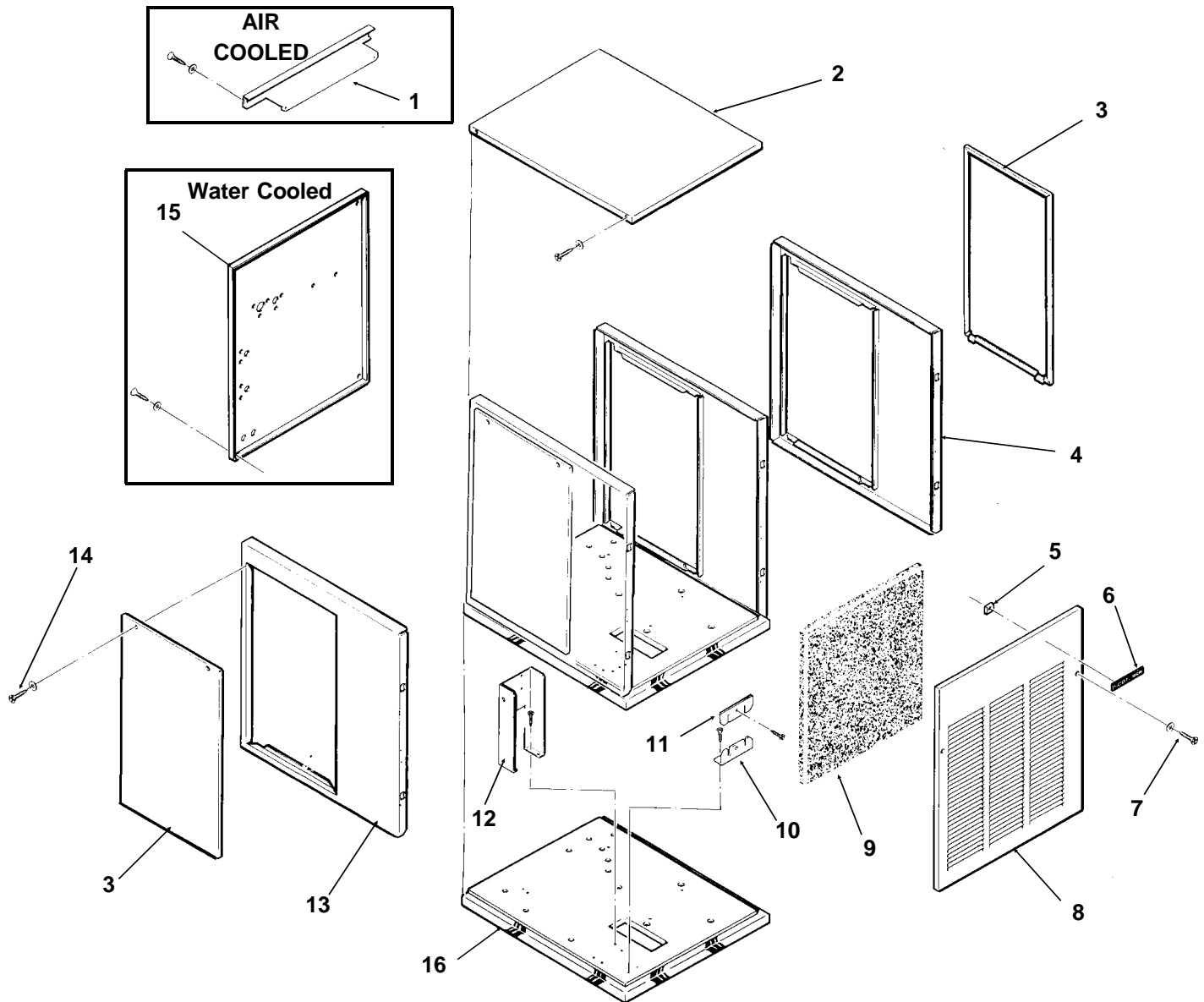

ITEM NUMBER	PART NUMBER	DESCRIPTION	ITEM NUMBER	PART NUMBER	DESCRIPTION
1	A33233-001	Condenser Support	9	02-2976-01	Filter Assembly
2	A33256-001	Top Panel, Painted	10	A31462-001	Tube Bracket
	A33256-002	Top Panel, S.S.	11	A31461-001	Tube Bracket
3	A34038-001	Service Panel, Painted	12	A34039-001	Control Box Support
	A34038-002	Service Panel, S.S.	13	A32435-001	Left Side Panel, Painted
4	A33292-001	Right Side Panel, Painted		A32435-002	Left Side Panel, S.S.
	A33292-002	Right Side Panel, S.S.	14	03-1404-12	Screw
5	03-0271-00	Speed Clip	15	A33252-001	Rear Panel, Water Cooled Painted Only
6	15-0711-01	Emblem			
7	03-1419-08	Screw	16.	A34042-001	Base
8	A33255-001	Front Panel, Painted			
	A33255-002	Front Panel, S.S.			

NM952 SERVICE PARTS

Air Cooled Refrigeration

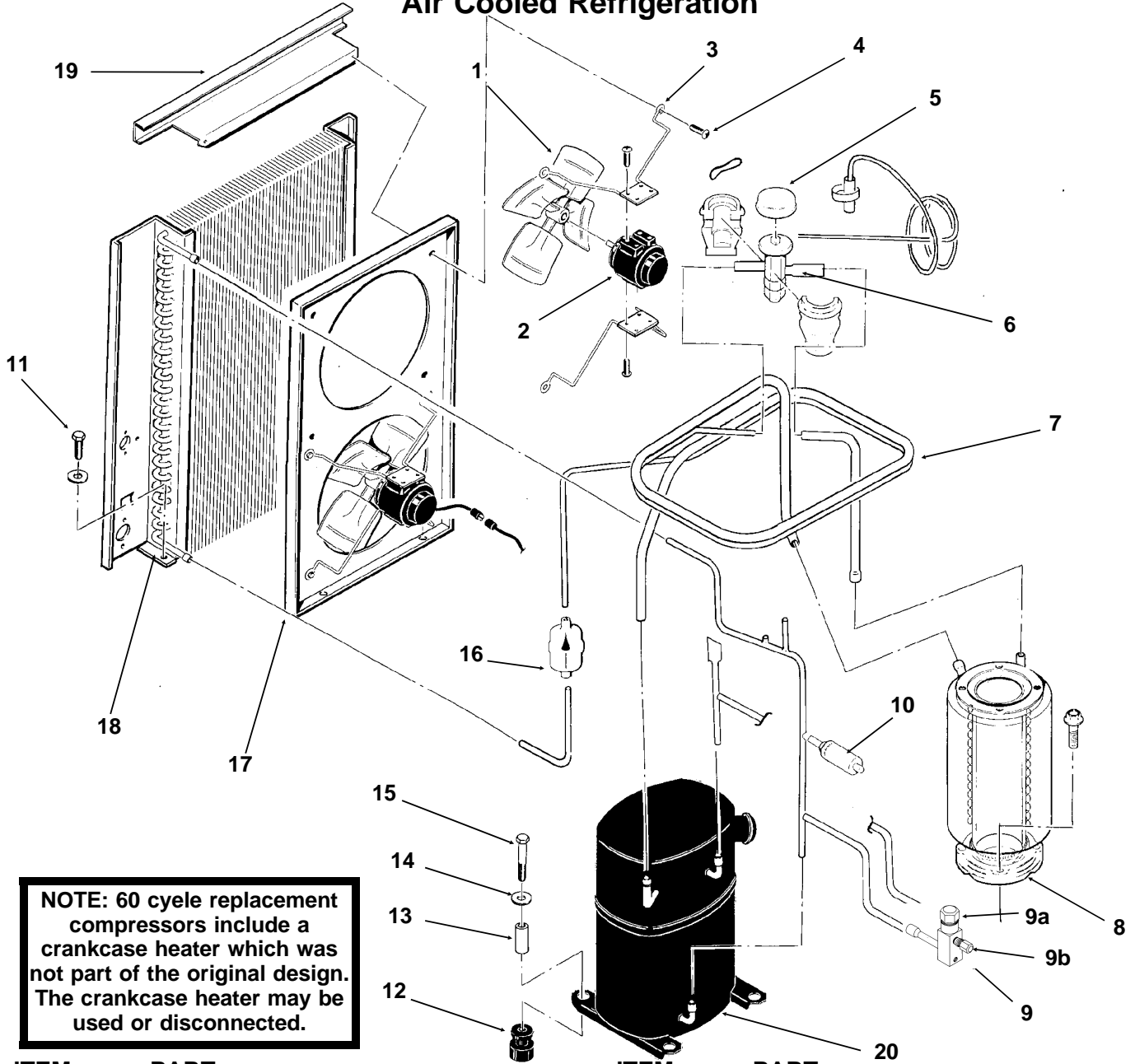

NOTE: 60 cycle replacement compressors include a crankcase heater which was not part of the original design. The crankcase heater may be used or disconnected.

ITEM NUMBER	PART NUMBER	DESCRIPTION	ITEM NUMBER	PART NUMBER	DESCRIPTION
1	18-3815-01	Fan Blade	12	18-6800-01	Grommet
2	12-1576-02	Fan Motor	13	18-2300-27	Sleeve
3	02-2378-01	Fan Bracket	14	03-1407-07	Washer
4	03-1531-01	Screw	15	03-1405-20	Cap Screw
5	A32961-020	Insulation Kit (3 piece)	16	02-2426-02	Dryer
6	11-0477-20	Thermo Expansion Valve	17	A33231-001	Fan Shroud
7	A35566-001	Suction Line	18	18-8717-01	Condenser
8	A32890-020	Evaporator	19	A33233-001	Condenser Mount
9	16-0832-20	Access valve	20	18-8716-23	Compressor 208-230/60/1
9a	16-0832-02	Stem cap		18-8716-25	Compressor 200-230/60/3
9b	16-0832-03	Core cap		18-8716-26	Compressor 220-240/50/1
10	11-0446-27	Hi Pressure Cut Out			(18-8716-26 for 50 cycle only)
11	03-1645-01	Screw			

all compressors have internal overloads
 18-8716-23, 18-8716-25 have crankcase heaters

NM952 SERVICE PARTS

Water Cooled Refrigeration

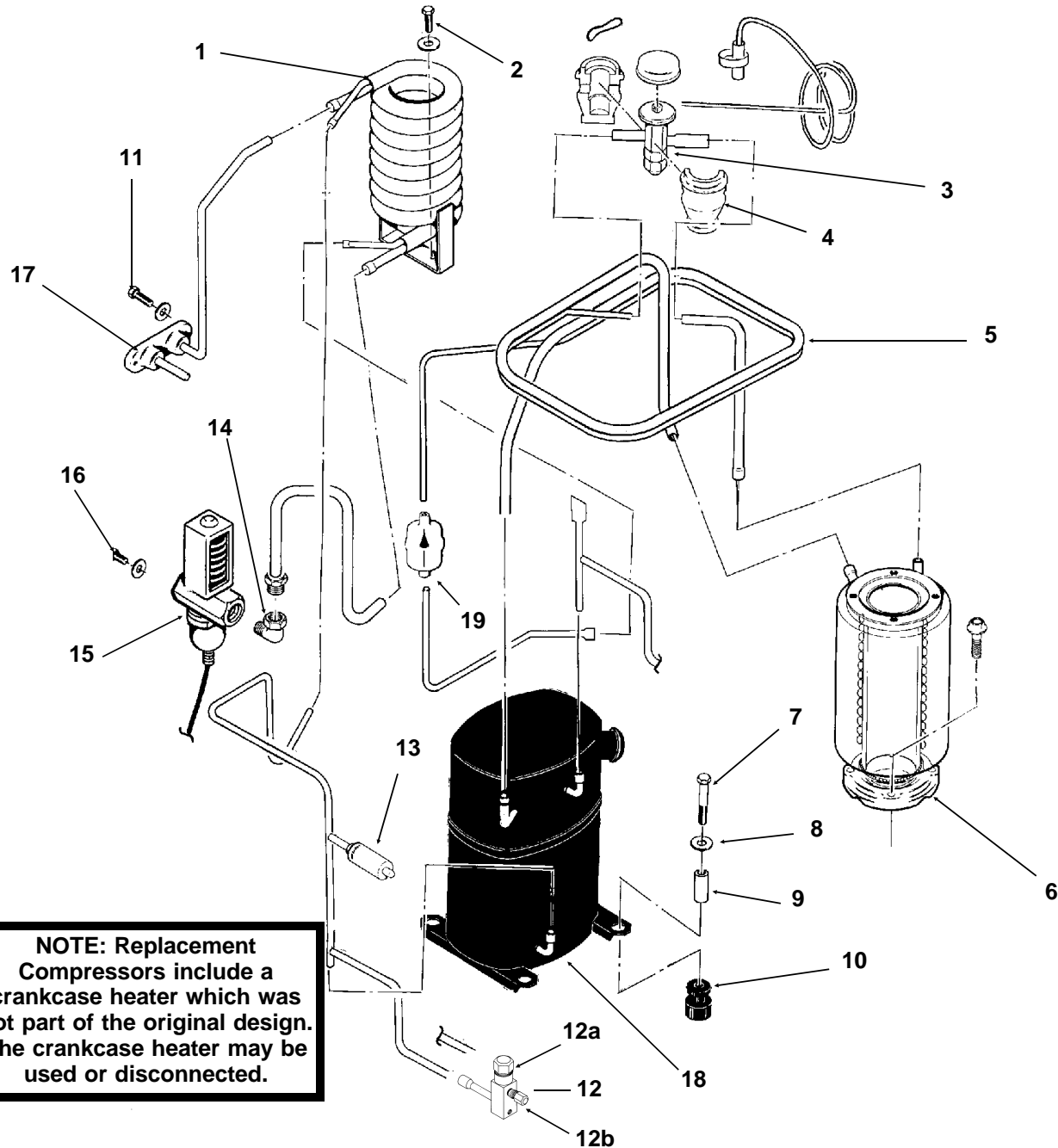

NOTE: Replacement Compressors include a crankcase heater which was not part of the original design. The crankcase heater may be used or disconnected.

ITEM NUMBER	PART NUMBER	DESCRIPTION	ITEM NUMBER	PART NUMBER	DESCRIPTION
1	18-8718-25	Condenser	12	16-0832-20	Access Valve
2	03-1645-01	Screw	12a	16-0832-02	Stem cap
3	11-0477-20	Thermo Expansion Valve	12b	16-0832-03	Core cap
4	A32961-020	Insulation Kit (3 piece)	13	11-0446-27	Hi Pressure Cut Out
5	A35566-001	Suction Line	14	16-0401-02	Elbow
6	A32890-020	Evaporator	15	11-0424-21	Water Reg. Valve
7	03-1405-20	Cap Screw	16	03-1403-14	Screw
8	03-1407-07	Washer	17	A34044-001	Drain Assembly
9	18-2300-26	Sleeve	18	18-8716-23	Compressor 208-230/60/1
10	18-6800-01	Grommet		18-8716-25	Compressor 200-230/60/3
11	03-1645-01	Screw		18-8716-26	Compressor 220-240/50/1
					(all have internal overloads & 18-8716-23, 18-8716-25 have crankcase heaters)
			19	02-3319-02	Dryer

NM952 SERVICE PARTS

Water System

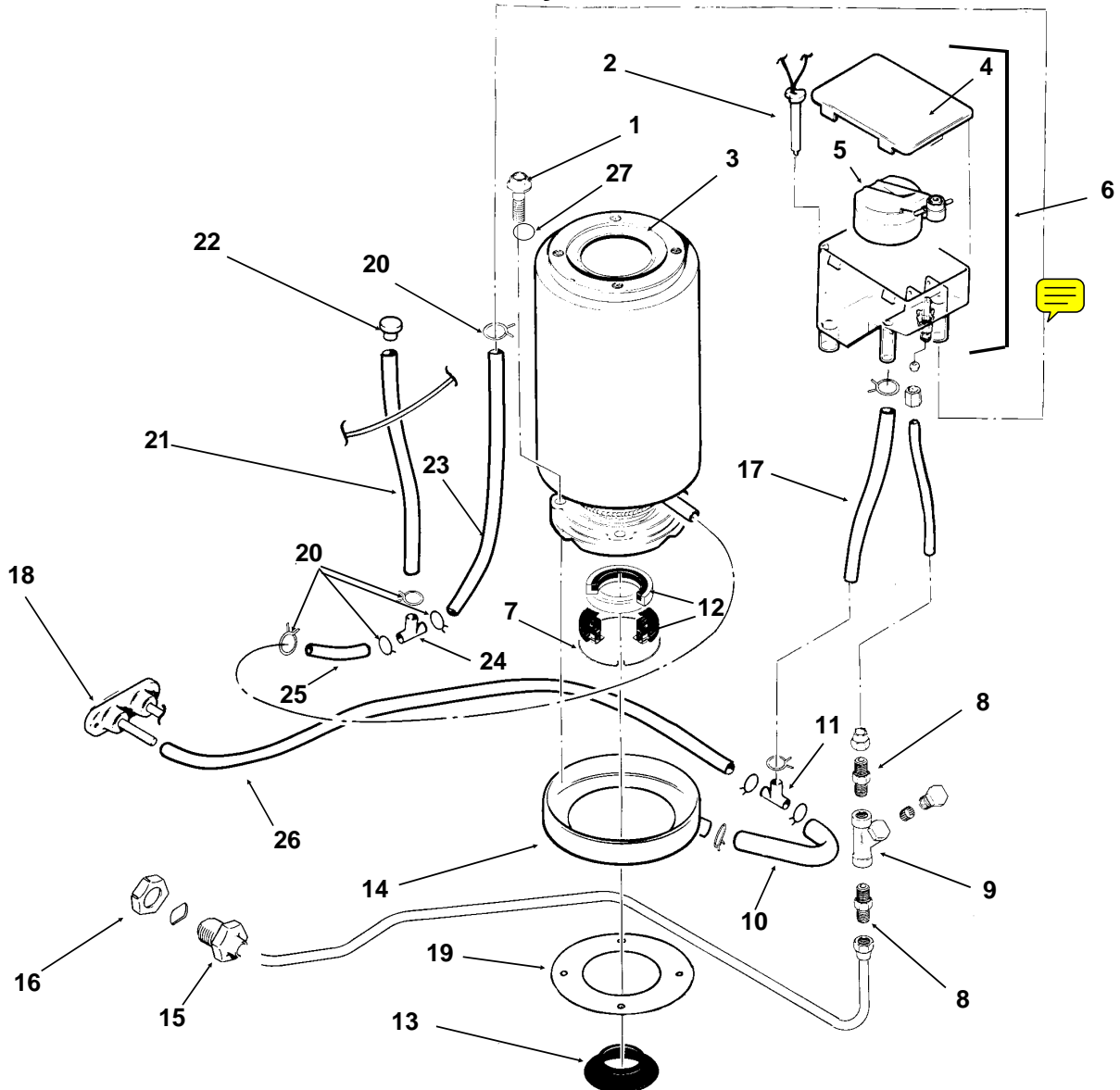

ITEM NUMBER	PART NUMBER	DESCRIPTION	ITEM NUMBER	PART NUMBER	DESCRIPTION
1	03-1420-03	Cap Screw	14	A32050-001	Drip Pan
2	A33101-022	Water Level Sensor	15	A27318-001	Water Inlet Fitting
3	A32890-020	Evaporator	16	03-1394-01	Pal Nut
4	02-2936-01	Res. Cover	17	13-0079-03	Res. Overflow, 8" req.
5	A32922-020	Float Assembly with pin housing seal, rubber seat, insert & float	18	A34045-001	Drain Casting, air cooled
	02-3190-01	Rubber seat	19	13-0704-00	Gasket
6	A32929-020	Reservoir Assy Complete	20	02-2814-08	Clamps
7	A32777-001	Retaining Ring for seal	21	13-0674-06	Evap. Drain, 14" req.
8	16-0791-01	Half Union	22	13-0840-01	Plug
9	16-0162-00	Strainer	23	13-0674-06	Evap. Inlet Tube, 5" req.
10	13-0079-03	Tube, 3.2" req.	24	16-0670-01	Tee
11	16-0670-02	Tee	25	A33203-001	Tube, Preformed
12	02-0929-23	Water Seal	26	13-0079-03	Drain Tube, 24" req.
13	13-0868-01	Water Shed	27.	03-1417-13	Lockwasher

NM952 SERVICE PARTS

Gearmotor

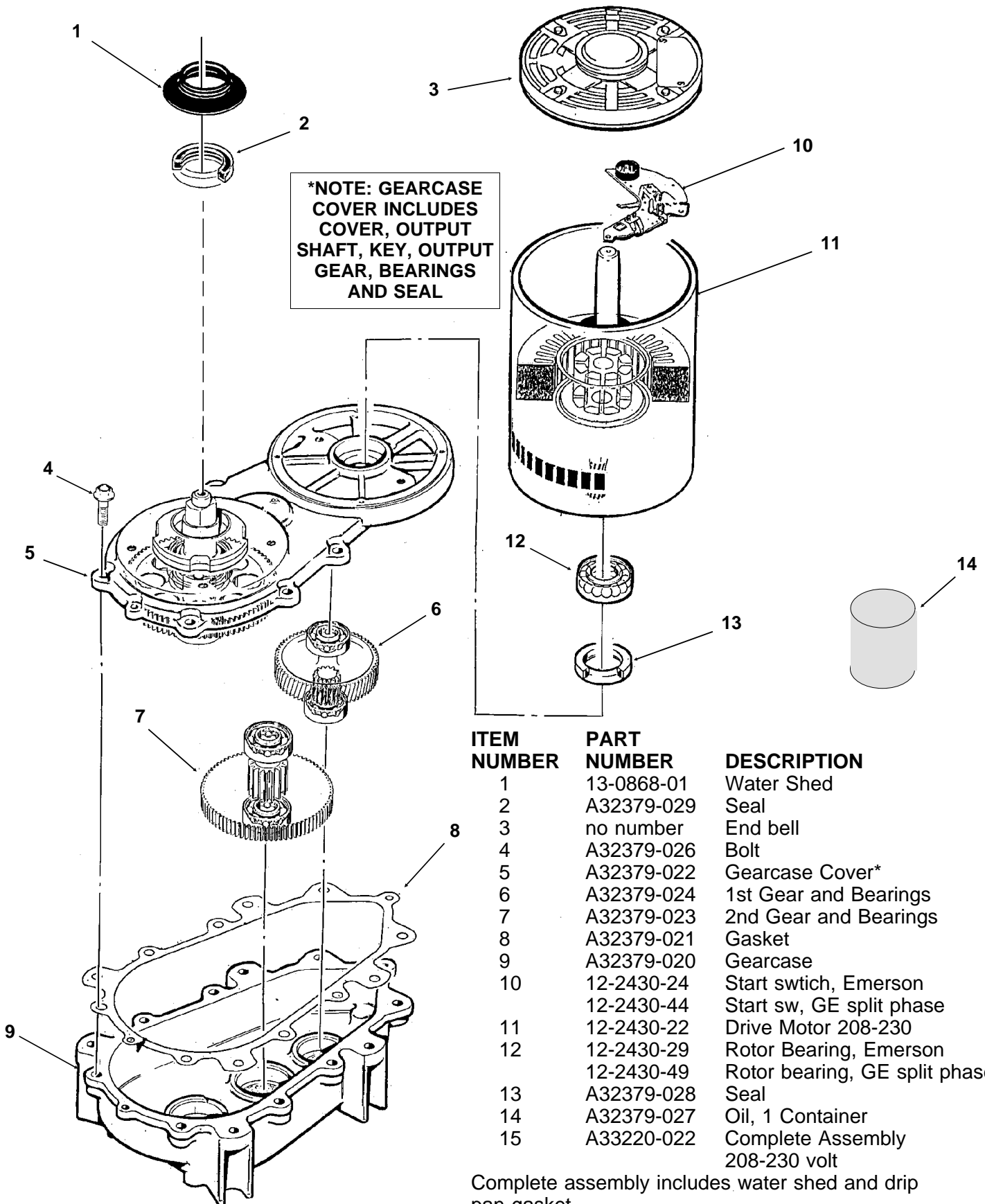

ITEM NUMBER	PART NUMBER	DESCRIPTION
1	13-0868-01	Water Shed
2	A32379-029	Seal
3	no number	End bell
4	A32379-026	Bolt
5	A32379-022	Gearcase Cover*
6	A32379-024	1st Gear and Bearings
7	A32379-023	2nd Gear and Bearings
8	A32379-021	Gasket
9	A32379-020	Gearcase
10	12-2430-24	Start swtich, Emerson
	12-2430-44	Start sw, GE split phase
11	12-2430-22	Drive Motor 208-230
12	12-2430-29	Rotor Bearing, Emerson
	12-2430-49	Rotor bearing, GE split phase
13	A32379-028	Seal
14	A32379-027	Oil, 1 Container
15	A33220-022	Complete Assembly 208-230 volt

Complete assembly includes water shed and drip pan gasket.

A33220-030 Gears, oil & covers. No motor

NM952 SERVICE PARTS

Evaporator

Not Illustrated:
Bail Clamp, pn
A34969-001

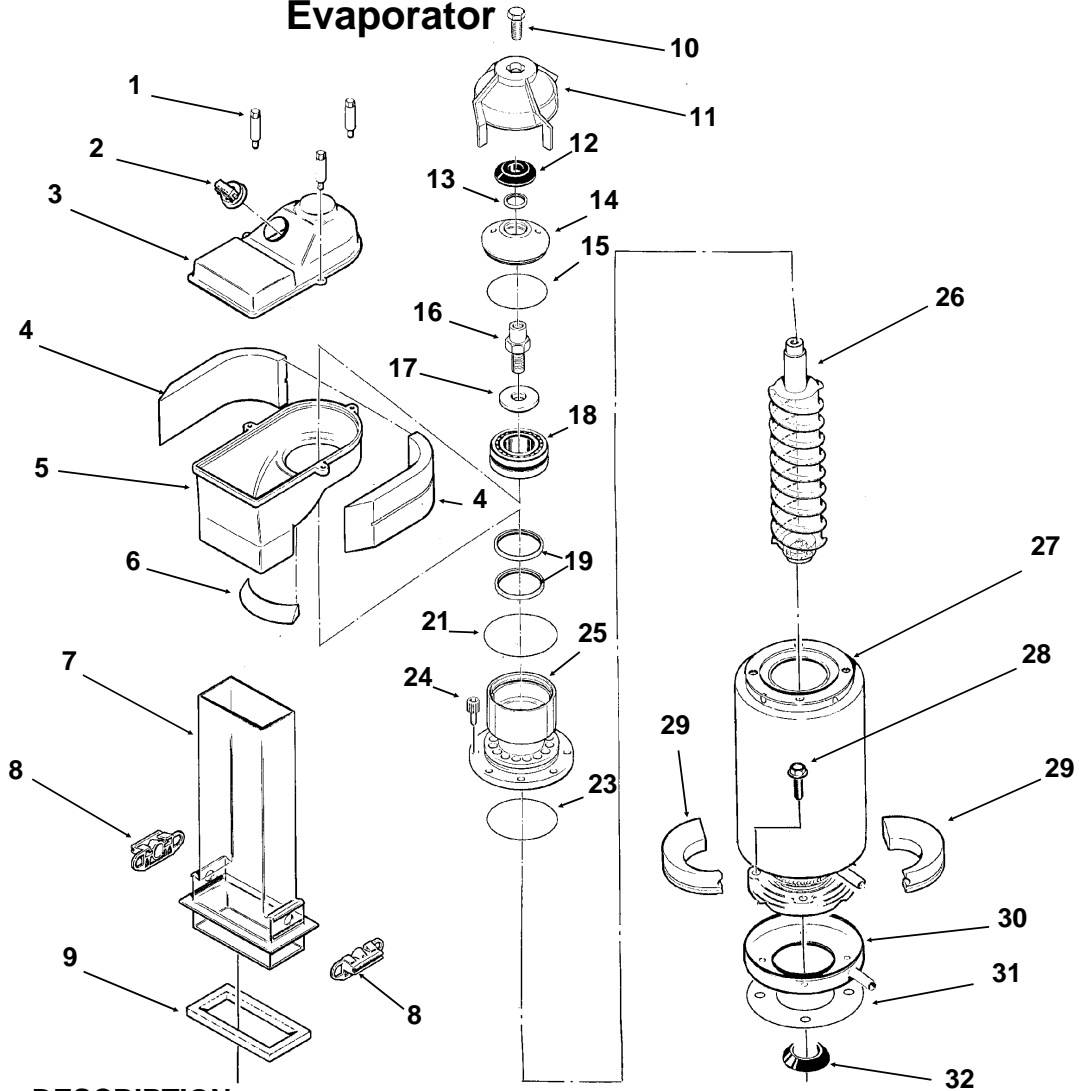

ITEM NUMBER	PART NUMBER	DESCRIPTION
1.	02-2933-01	Hex Stud
2.	A32891-020	Switch assembly
	13-0617-53	O-ring
	12-2398-01	Manual reset switch
3.	02-2930-01	Ice Chute Cover
4.	A32963-001	Insulation Top (half)
5.	02-2926-01	Ice Chute Body
6.	A33102-001	Insulation Collar Inside
	A35419-020	Strap kit
7.	02-2929-01	Ice Chute Lower
8.	A37708-021	Bin Controls Assy.
	(set of 2)	
9.	A32930-001	Chute Gasket
10.	03-1405-52	Hex Cap Screw
11.	02-3001-01	Ice Sweep
12.	13-0871-01	Water Shed
13.	02-2978-01	Lip Seal
14.	02-2138-20	Breaker Cover
15.	13-0617-54	O-Ring
16.	08-0660-01	Auger Stud, includes 17
17.	no number	Thrust Washer. part of item 16
18.	A34559-020	Bearing
19.	02-2977-01	Lip Seal
20.	no number	
21.	13-0617-52	O-Ring
22.	no number	
23.	13-0617-45	O-Ring
24.	03-1544-08	Soc. Head Screw
25.	A32900-020	Breaker (includes 13,14,15, 18,19 & 23)
26.	A38071-022	Auger
27.	A32890-020	Evaporator
28.	03-1405-41	Cap Screw
29.	A32962-001	Insulation Bot. (half)
30.	A32050-001	Drip Pan
31.	13-0704-00	Drip Pan Gasket
32.	13-0868-01	Water Shed

NM952 SERVICE PARTS

Control Box

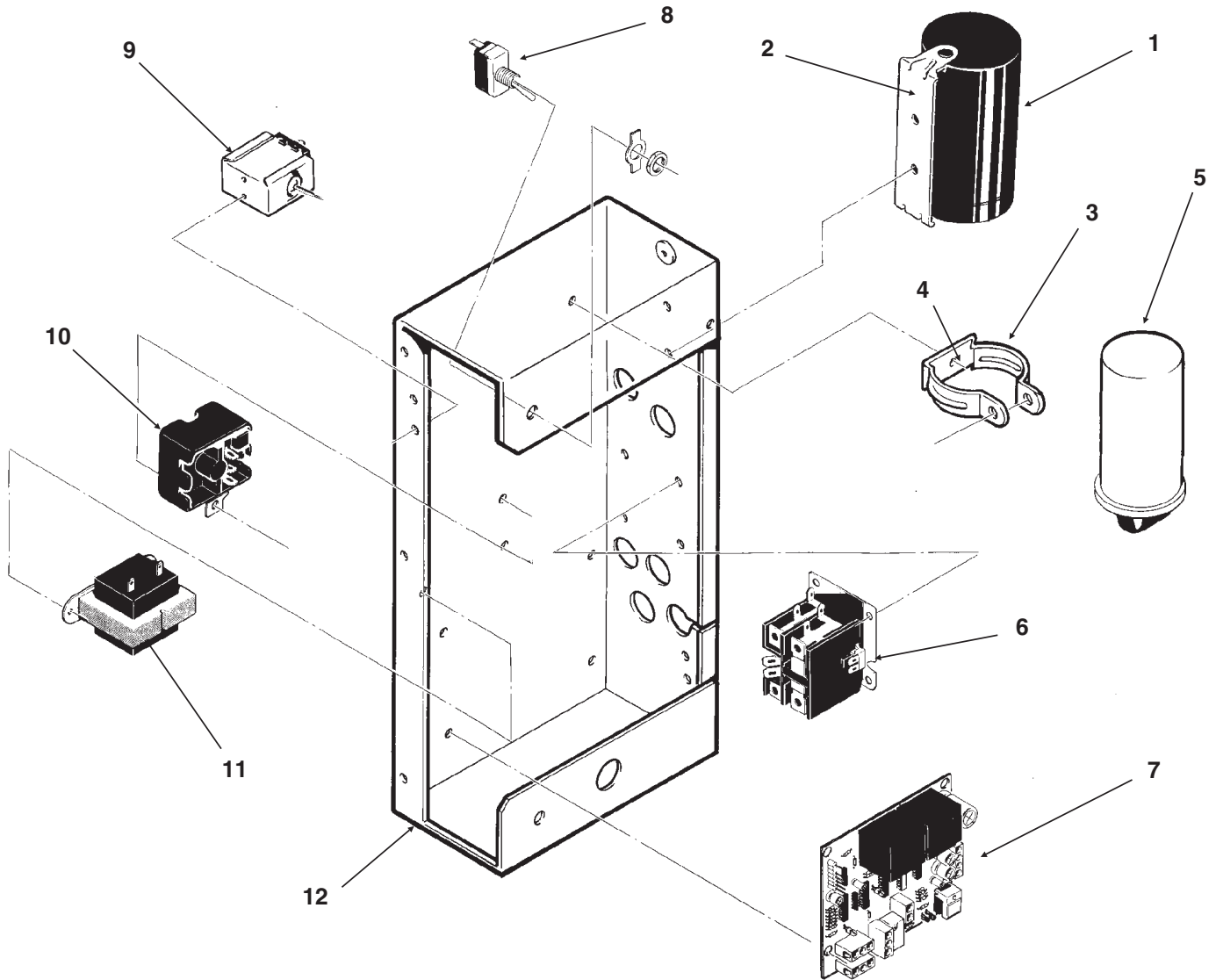

ITEM NUMBER	PART NUMBER	DESCRIPTION	ITEM NUMBER	PART NUMBER	DESCRIPTION
1	18-1901-15	Start Capacitor, 60 Hz	7	A37750-021	Circuit Board
	18-1901-23	Start Capacitor, 50 Hz	8.	12-0426-01	Master Switch
	18-2200-38	Start Capacitor Cap.	9.	11-0447-20	Low Pressure Control
2.	18-2200-39	Start Capacitor Bracket	10	18-1903-33	Potential Relay, all Hz
	03-1638-04	Screw		18-1903-46	Potential relay, 50 Hz
	03-1417-15	Lockwasher	11.	12-2285-22	Transformer
3.	A32872-001	Run Cap Bracket	12	no number	Control Box
	03-1652-02	Bolt	NOT ILLUSTRATED		
	03-0255-04	Wing Nut	13.	12-2337-02	3 Pin Plug Assy
4.	03-1638-03	Screw			(Safety Circuit to Circuit Board)
5.	18-1902-53	Run capacitor, all	14.	12-2340-01	4 Pin Plug Assy
6.	12-2469-02	Single Phase Contactor			(Transformer to Circuit Board)
	12-0739-02	Three phase contactor	15.	A34055-001	Control Box Cover

Note: Hz means Cycles, 50 Hz is 50 cycle, the model number ends in a -6 for 50 Hz models.

NM952 SERVICE PARTS

AIR AND WATER COOLED, 208-230/60/1

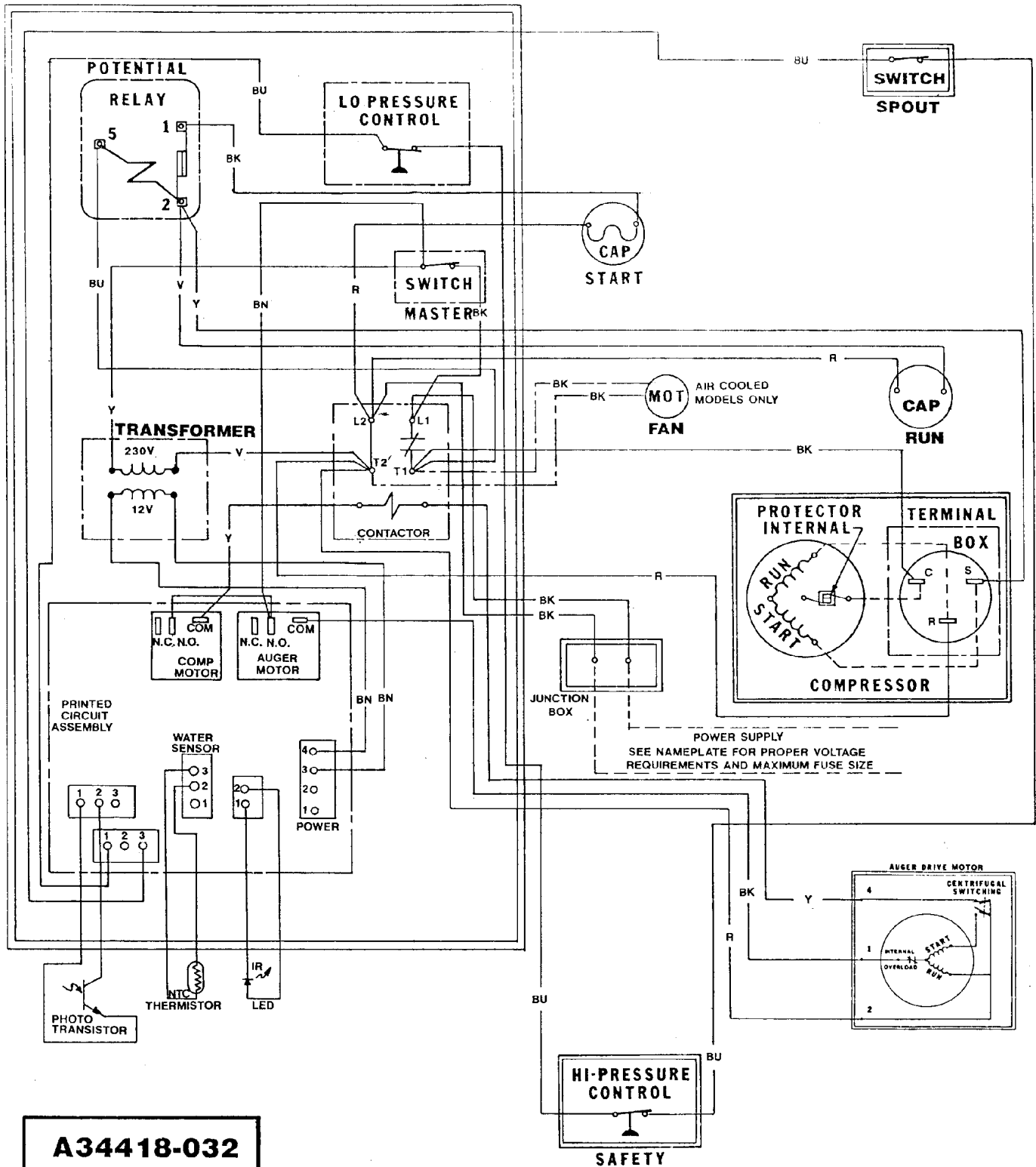

A34418-032

NM952 SERVICE PARTS

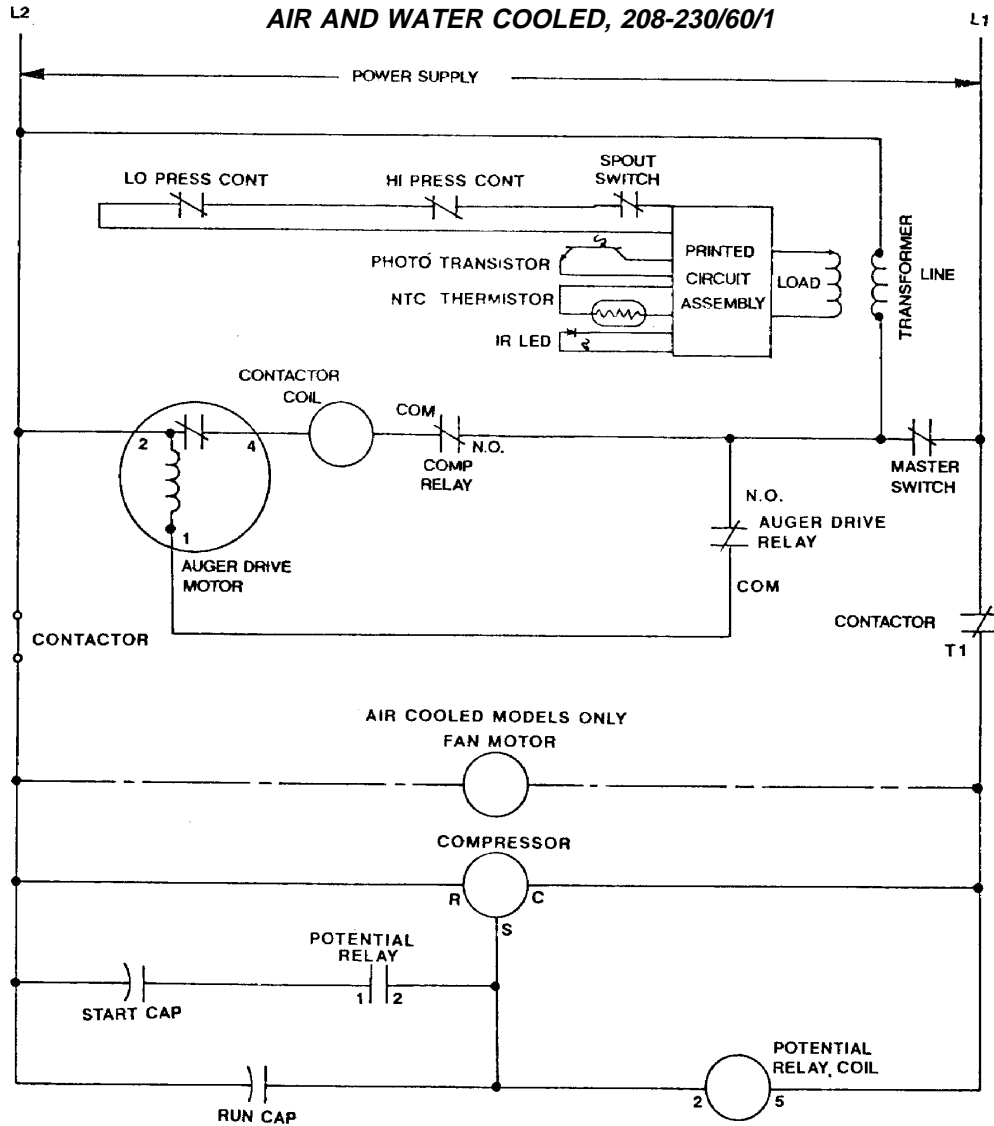

**USE COPPER CONDUCTORS ONLY
ALL CONTROLS SHOWN IN NORMAL ICEMAKING MODE
THIS UNIT MUST BE GROUNDED**

NM952 SERVICE PARTS

AIR AND WATER COOLED, 208-230/60/3

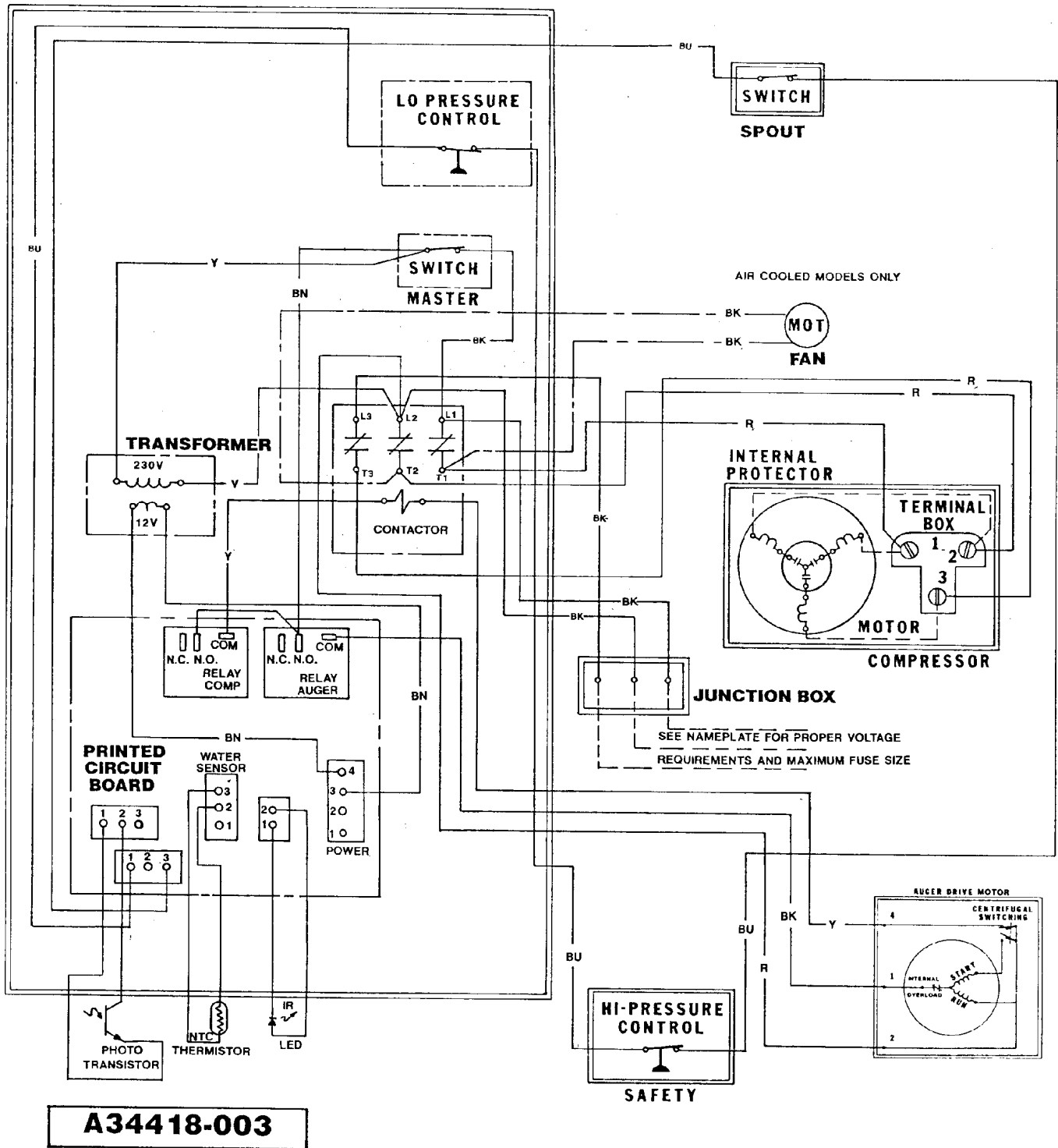

NM952 SERVICE PARTS

