

DISHWASHER

ELECTROMECHANICAL SWITCHES
ELECTRONICAL SWITCHES
LOWER WASHING
LOWER AND UPPER WASHING
INSULATED MODEL

TYPE: LUX40EL

Accessories
BREAK TANK
BOOSTER PUMP
DVGW
COLD RINSE
WATER SOFTNER
DETERGENT DISPENSER
DRAIN PUMP

Spare Parts Manual

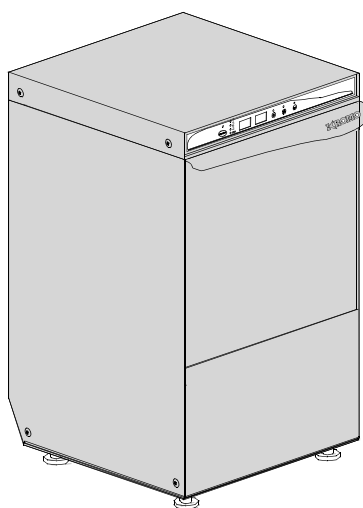

INFORMAZIONI GENERALI

Questo catalogo serve per richiedere con esattezza le parti di ricambio

Nelle ordinazioni indicare:

1) il numero dei codici dei particolari seguito dalla descrizione e la quantità desiderata;

2) Il codice alfa-numerico presente nella seconda colonna della tabella ;

I disegni delle parti di ricambio sono solo indicativi e non rappresentano il pezzo in oggetto.

I dati contenuti in questo catalogo sono indicativi e possono essere soggetti a modifiche senza impegno di preavviso.

ALLGEMEINE INFORMATIONEN

Dieser Ersatzteilkatalog dient zur genauen Angabe der Teile bei Ersatzteilbestellungen.

Bei Ersatzbestellung ist folgendes anzugeben:

1) Die Bestellnummer der Ersatzteile mit der entsprechenden Beschreibung genaue Menge;

2) Der alpha-numerischer Code auf der zweiten Reihe in dein Spalte;

Die Zeichnungen der Ersatzteile sind nur als Hinweise gedacht und stellen nicht das betroffene Teil dar.

Bei den im Katalog angeführten Daten handelt es sich um Anhaltsdaten, die jederzeit, ohne Vorankündigung, geändert werden können.

GENERAL INFORMATION

The present spare parts order exactly the right spare parts

When ordering specify:

1) the part's code number followed by its description and quantity needed;

2) The alpha-numeric code is in the second column in the chart;

Spare parts drawings are general and do not represent the part.

The contents of this catalogue are general and can undergo changes without prior notice.

INFORMACIONES GENERALES

El presente catálogo sirve para pedir con exactitud las partes de repuesto

En los pedidos se debe indicar:

1) el número de código de la parte y a continuación la descripción cantidad deseada;

2) El código alfanumerico presente en la signada columna de la tabla;

Los diseños de las partes de recambio son solo indicativos y no representan la pieza en cuestión.

Los datos contenidos en el presente catálogo son indicativos y pueden modificarse sin aviso previo.

INFORMATIONS GENERALES

Ce catalogue permet de commander correctement les pièces détachées

Les commandes doivent être passées en indiquant:

1) le numero de code des pièces détachées suivi de leur description quantité désirée;

2) le code alphanumérique dans la deuxième colonne du tableau;

Les plans des pièces détachées sont fournis seulement à titre indicatif et ne représentent pas la pièce concernée.

Les données de ce catalogue sont citées seulement à titre indicatif et peuvent être l'objet de modifications sans avis préalable.

ESEMPIO
EXAMPLE
EXEMPLE
BEISPIEL

Rif.	Codici
MODULE:Particolari	
10505	540903
10510	540908
10515	15065/A
10520	540086
10525	540028



Note

Tutte le informazioni riportate si intendono aggiornate alla data di stampa. Il Produttore si riserva il diritto di apportare qualsiasi modifica richiesta dallo sviluppo evolutivo dei suddetti prodotti.

Per la sicurezza, la garanzia, l'affidabilità ed il valore della lavastoviglie usa solo ricambi originali. **Per alcuni codici, sono richieste quantità minime d'ordine.**



Attenzione

Questo libretto è parte integrante della lavastoviglie e, in caso di passaggio di proprietà, deve essere consegnato al nuovo acquirente.



Remarque

Toutes les informations contenues dans ce manuel s'entendent mises à jour à la date d'impression. En raison du développement constant de ses produits, usine se réserve le droit d'apporter à tout instant les modifications qu'elle jugera utiles.

Pour la sécurité, la garantie, la fiabilité et la valeur de votre lave-vaisselles n'utilisez que des pièces de rechange d'origine. **Pour quelque référence on demande un minimum de pièces par commande**



Attention

Ce manuel doit être considéré comme partie intégrante de la lave-vaisselles, en cas de transfert de propriété, doit toujours être remis au nouveau propriétaire.



Note

The information contained herein is valid at the time of going to print. The Company reserves the right to make any changes required by the future development of the above-mentioned products.

For your safety, as well as to preserve the warranty reliability and worth of your dishwashers, use original spare parts only. **For some codes a minimum quantity for order is required.**



Warning

This manual forms an integral part of the dishwashers and - if a transfer of title occurs - must always be handed over to the new owner.



Hinweis

Die Der Hersteller behält sich das Recht vor, jegliche, durch eine Weiterentwicklung der genannten Produkte bedingte Änderungen vornehmen zu können.

Verwenden Sie für Ihre Sicherheit, die Garantie, die Zuverlässigkeit und den Wert Ihrer machine originale Ersatzteile. **Für bestimmte Code nummer werden mindesten bestellungen verlangt.**



Achtung

Diese Betriebsanleitung ist Bestandteil des machine und muss bei seinem Weiterverkauf dem neuen Besitzer ausgehändigt werden.



Code DW 999XXXXXX
Model DESCRIPTION
S/N DW A 1015770 Type

400V 3N 50HZ 8A
3500W 500W



IPX3

Pressione Dinamica alimentazione idrica 200-500 kPa
 Pression dynamique arrivee d'eau
 Dynamic pressure water supply
 Dynamischer Druck asserreinlauf

Pressione dinamica vapore saturo
 Pression dynamique vapeur satuee
 Dymanischer Druck gesattigter Dampf
 Pression Dinamica Vapor Saturado

CL/Part

TECHICAL SPECIFICATION

MADE IN ITALY

Temperatura massima acqua in ingresso 60°C
 Temperature max eau a l'entre
 Maximale Temperatur Wasseranschlu
 Maximum Water temperature in-feeding



Model 

S/N 

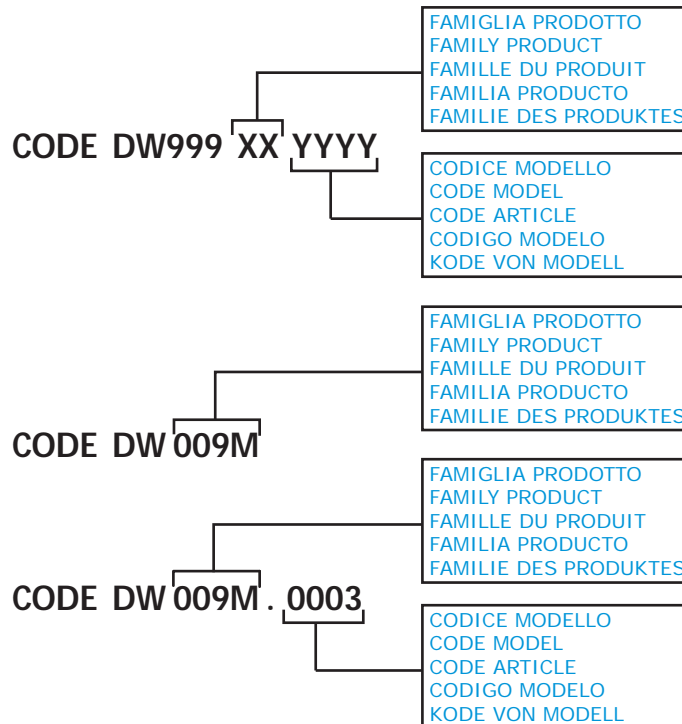

1. Spare parts

General body parts.....	9
Lockup system	11
Lockup system	13
Lockup system	15
Control panel and switches.....	17
Electric control	19
Solenoid valve group	21
Solenoid valve group	23
Solenoid valve group	25
Break Tank	27
Booster pump.....	29
DVGW	31
Water softner group.....	33
Rinse aid dispenser group.....	35
Rinse aid dispenser group.....	37
Boiler group	39

3 ways connection	41
3 ways connection	43
Wash pump	45
Wash pump	47
Dosing detergent group.....	49
Drain pump group.....	51
Drain pump group.....	53
Pressure switch group with air trap ...	55
Turret group with rotating arms	57
Turret group with rotating arms	61
Turret group with rotating arms	63
Turret group with rotating arms	65

1.1 Voltage codes

Volt	Voltage code
A	3/N/PE~380-400V 50-60Hz
D	3/PE~200-210V 50-60Hz
F	2/PE~220-240V 50-60Hz
G	3/N/PE~415V 50-60Hz
H	3/PE~220-230V 50-60Hz
K	3/PE~380-400V 50-60Hz
L	3/PE~415V 50-60Hz
M	3/PE~440V 60Hz
P	1/N/PE~220-230V 50-60Hz
R	2/PE~220-240V 50-60Hz
U	1/N/PE~240V 50-60Hz
V	3/PE~240V 50-60Hz
W	1/N/PE~100-110V 50-60Hz

1.2 Product codes

Product code	Full name
Model codes	
em	ELECTROMECHANICAL SWITCHES
e	ELECTRONICAL SWITCHES
lw	LOWER WASHING
uw	LOWER AND UPPER WASHING
i	INSULATED MODEL
Type codes	
LUX40EL	LUX40EL
Accessory codes	
bt	BREAK TANK
bp	BOOSTER PUMP
dvgw	DVGW
cr	COLD RINSE
ws	WATER SOFTNER
dd	DETERGENT DISPENSER
dp	DRAIN PUMP

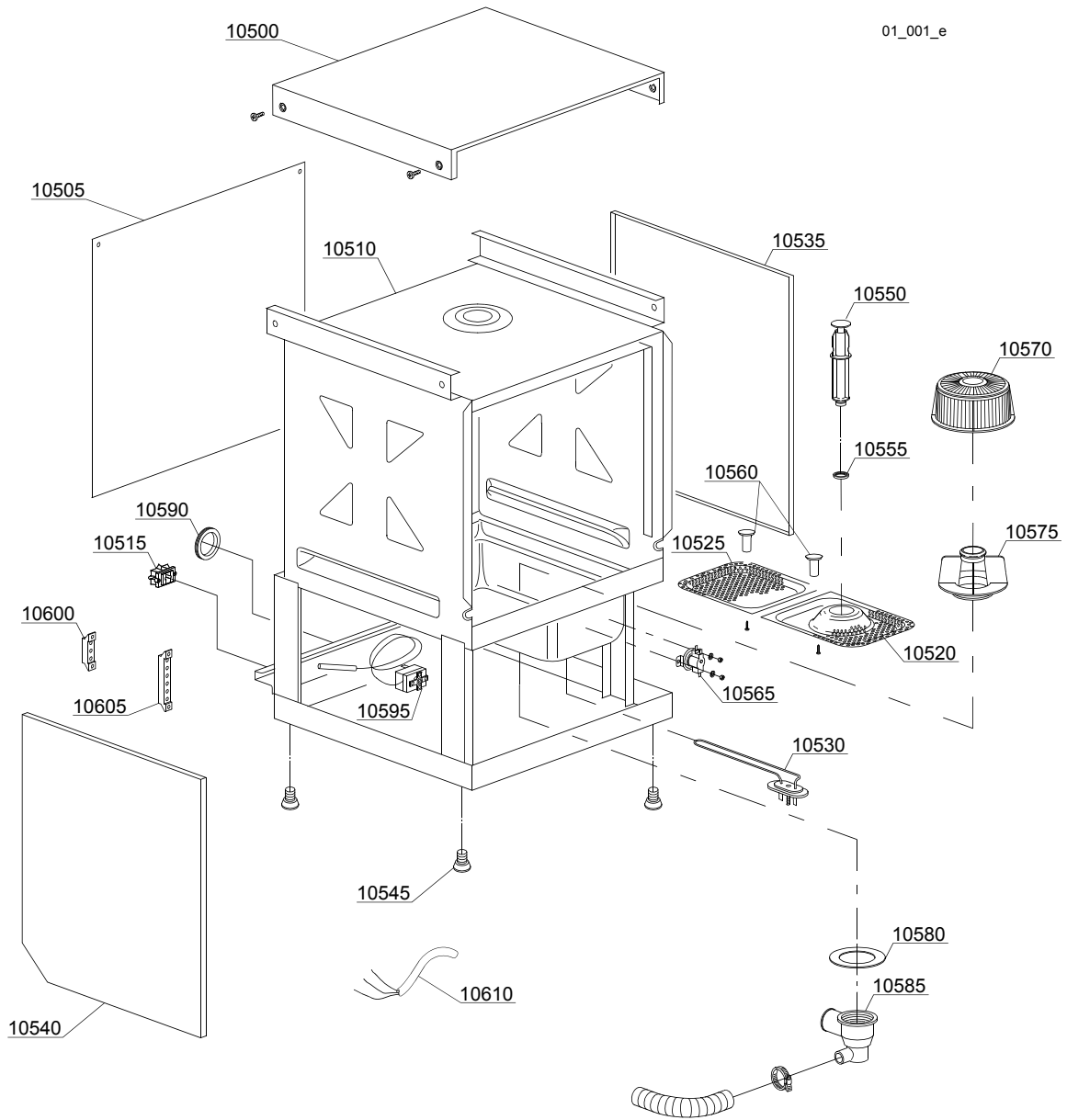

Spare parts

ID	P-code	SN from	SN to	Mod.	Acces.	Volt	Description
Module:General body parts							
10500	540913		-				Cover
10505	540903		-				Back panel
10510	540908		-				Body
10510	540921		-		ws		Body
10515	15065/A		-				Cable-fastener with screw
10520	540027		-				Surface half-filter
10525	540028		-				Surface half-filter
10530	540401		-				1,1/1,2 KW 230/240V heating element
10535	540900		-				Right side
10540	540901		-				Left side
10545	10850		-				Foot (minimum 4 pieces)
10550	540033		-				Overflow pipe
10555	13021		-				DEM 40 O-ring (minimum 2 pieces)
10560	540039		-				Surface filter handle
10565	15551		-				Fixed tank thermostat in deviation
10570	500620		-				Filter
10575	500615		-				Ferrule with filter
10580	80208		-				95x75x3 O-ring (minimum 2 pieces)
10585	500606		-				Right side scrap tray
10590	13317		-				D.40mm unloading pipe pass (minimum 2 pieces)
10595	10707/1		-				0-90°C thermostat
10600	500550		-				3 poles terminal board
10605	500551		-				6 poles terminal board
10610	10713		-				3x2,5x2500 cable
10610	15118		-				5x2,5 cable

em=ELECTROMECHANICAL SWITCHES, e=ELECTRONICAL SWITCHES, lw=LOWER WASHING, uw=LOWER AND UPPER WASHING, i=INSULATED MODEL

LUX40EL=LUX40EL

bt=BREAK TANK, bp=BOOSTER PUMP, dvgw=DVGW, cr=COLD RINSE, ws=WATER SOFTNER, dd=DETERGENT DISPENSER, dp=DRAIN PUMP

A=3/N/PE~380-400V 50-60Hz, D=3/PE~200-210V 50-60Hz, F=2/PE~220-240V 50-60Hz, G=3/N/PE~415V 50-60Hz, H=3/PE~220-230V 50-60Hz, K=3/PE~380-400V 50-60Hz, L=3/PE~415V 50-60Hz, M=3/PE~440V 60Hz, P=1/N/PE~220-230V 50-60Hz, R=2/PE~220-240V 50-60Hz, U=1/N/PE~240V 50-60Hz, V=3/PE~240V 50-60Hz, W=1/N/PE~100-110V 50-60Hz

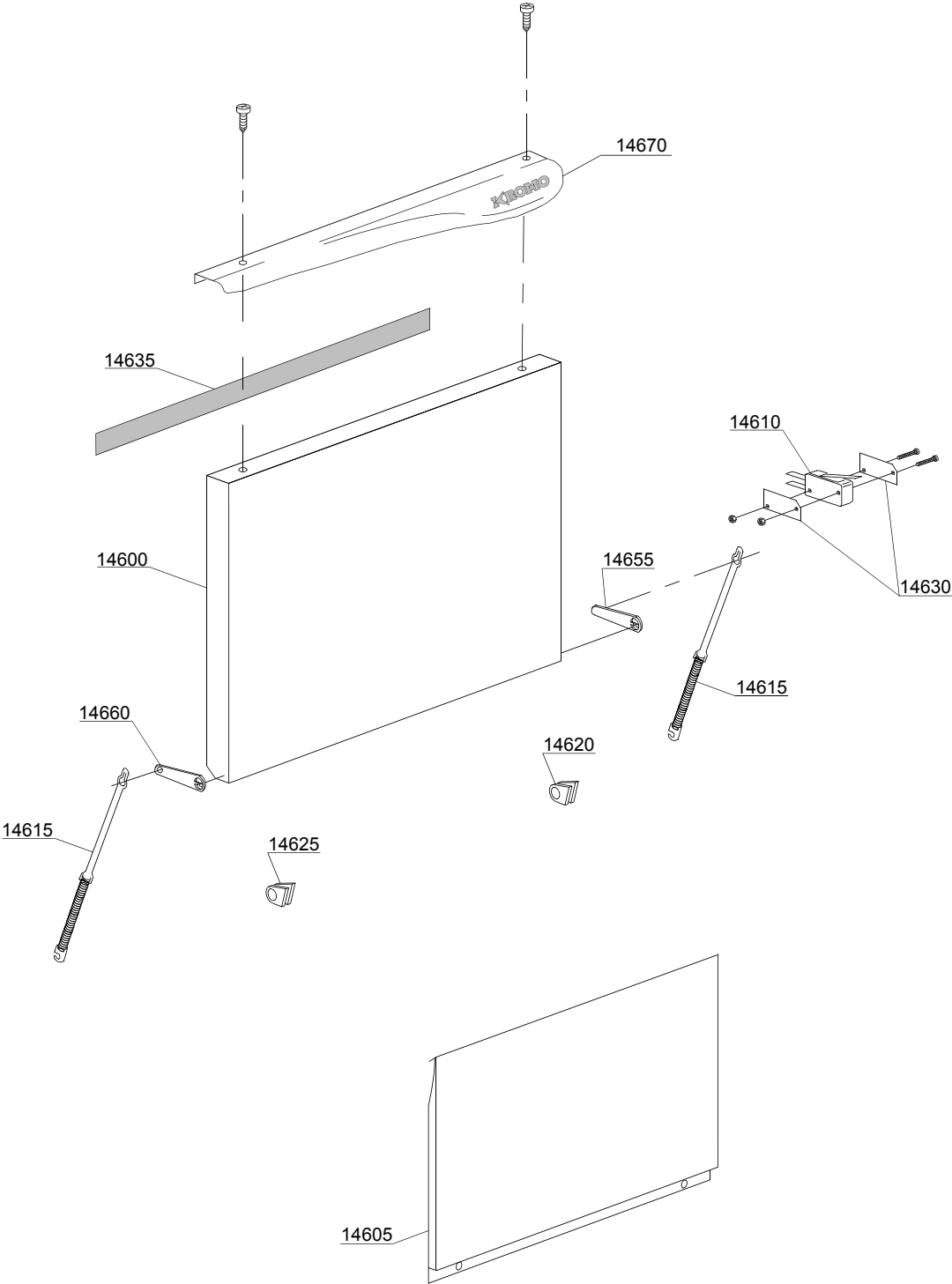

02_129_e

Spare parts

ID	P-code	SN from	SN to	Mod.	Acces.	Volt	Description
Module: Lockup system							
14600	540958		-				Door with steel handle
14605	540902		-				Lower door
14610	10704		-				Door microswitch
14615	560003		-				Door spring
14620	540035		-				Right axle bush for door hinge (minimum 2 pieces)
14625	540036		-				Left axle bush for door hinge (minimum 2 pieces)
14630	10770		-				Insulation for door microswitch (minimum 3 pieces)
14635	560021		-				Profile for door O-ring
14640	540050		-				Square tank
14645	540044		-				Shining product tank cover
14650	540049		-				Back tank cover
14655	540624		-				Right arm for door
14660	540629		-				Left arm for door
14670	540961		-				Steel handle

em=ELECTROMECHANICAL SWITCHES, e=ELECTRONICAL SWITCHES, lw=LOWER WASHING, uw=LOWER AND UPPER WASHING, i=INSULATED MODEL

LUX40EL=LUX40EL

bt=BREAK TANK, bp=BOOSTER PUMP, dvgw=DVGW, cr=COLD RINSE, ws=WATER SOFTNER, dd=DETERGENT DISPENSER, dp=DRAIN PUMP

A=3/N/PE~380-400V 50-60Hz, D=3/PE~200-210V 50-60Hz, F=2/PE~220-240V 50-60Hz, G=3/N/PE~415V 50-60Hz, H=3/PE~220-230V 50-60Hz, K=3/PE~380-400V 50-60Hz, L=3/PE~415V 50-60Hz, M=3/PE~440V 60Hz, P=1/N/PE~220-230V 50-60Hz, R=2/PE~220-240V 50-60Hz, U=1/N/PE~240V 50-60Hz, V=3/PE~240V 50-60Hz, W=1/N/PE~100-110V 50-60Hz

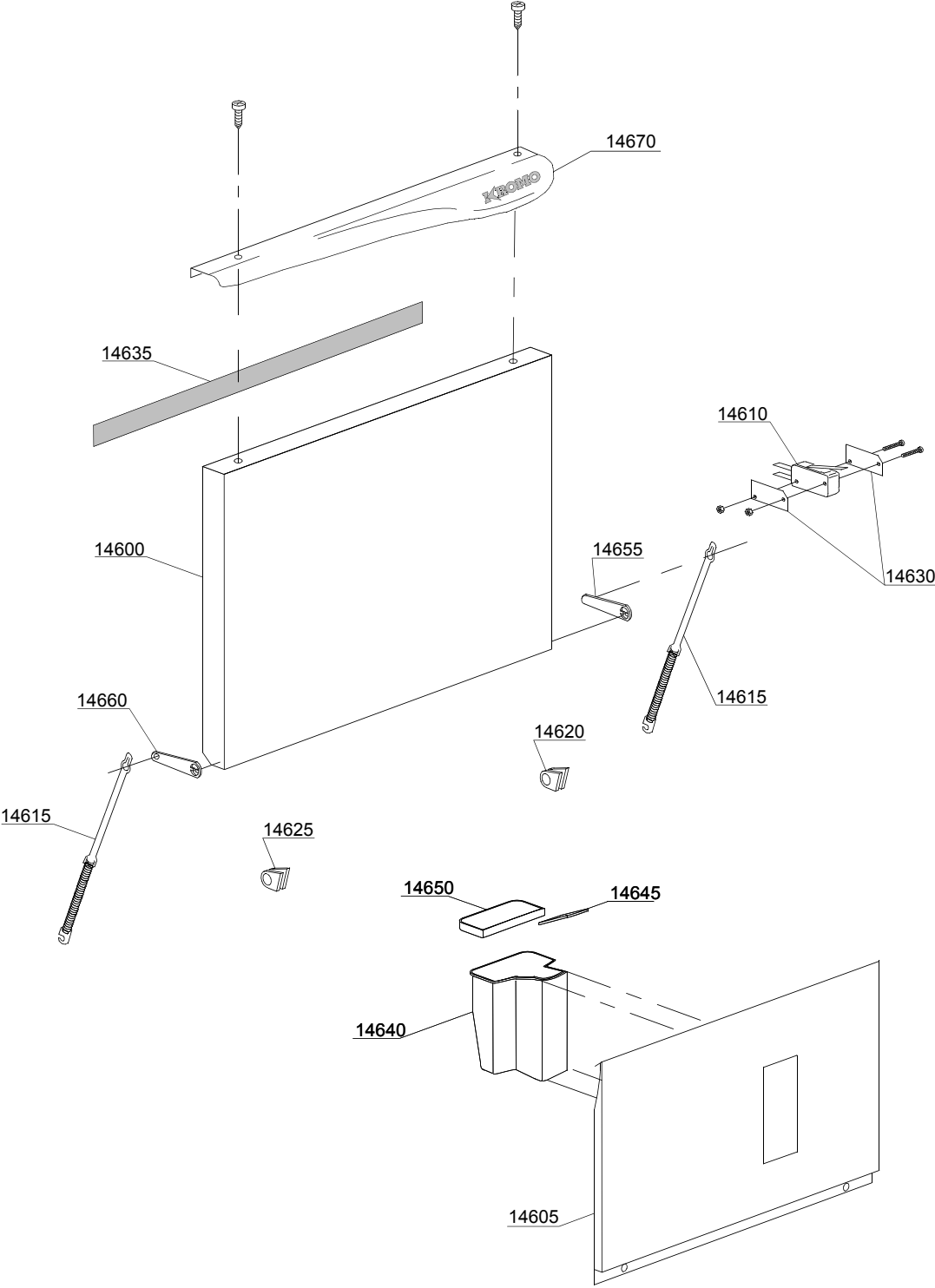

02_129ae

Spare parts

ID	P-code	SN from	SN to	Mod.	Acces.	Volt	Description
Module: Lockup system							
14600	540958		-				Door with steel handle
14605	540936		-				Lower door
14610	10704		-				Door microswitch
14615	560003		-				Door spring
14620	540035		-				Right axle bush for door hinge (minimum 2 pieces)
14625	540036		-				Left axle bush for door hinge (minimum 2 pieces)
14630	10770		-				Insulation for door microswitch (minimum 3 pieces)
14635	560021		-				Profile for door O-ring
14640	540050		-				Square tank
14645	540044		-				Shining product tank cover
14650	540049		-				Back tank cover
14655	540624		-				Right arm for door
14660	540629		-				Left arm for door
14670	540961		-				Steel handle

em=ELECTROMECHANICAL SWITCHES, e=ELECTRONICAL SWITCHES, lw=LOWER WASHING, uw=LOWER AND UPPER WASHING, i=INSULATED MODEL

LUX40EL=LUX40EL

bt=BREAK TANK, bp=BOOSTER PUMP, dvgw=DVGW, cr=COLD RINSE, ws=WATER SOFTNER, dd=DETERGENT DISPENSER, dp=DRAIN PUMP

A=3/N/PE~380-400V 50-60Hz, D=3/PE~200-210V 50-60Hz, F=2/PE~220-240V 50-60Hz, G=3/N/PE~415V 50-60Hz, H=3/PE~220-230V 50-60Hz, K=3/PE~380-400V 50-60Hz, L=3/PE~415V 50-60Hz, M=3/PE~440V 60Hz, P=1/N/PE~220-230V 50-60Hz, R=2/PE~220-240V 50-60Hz, U=1/N/PE~240V 50-60Hz, V=3/PE~240V 50-60Hz, W=1/N/PE~100-110V 50-60Hz

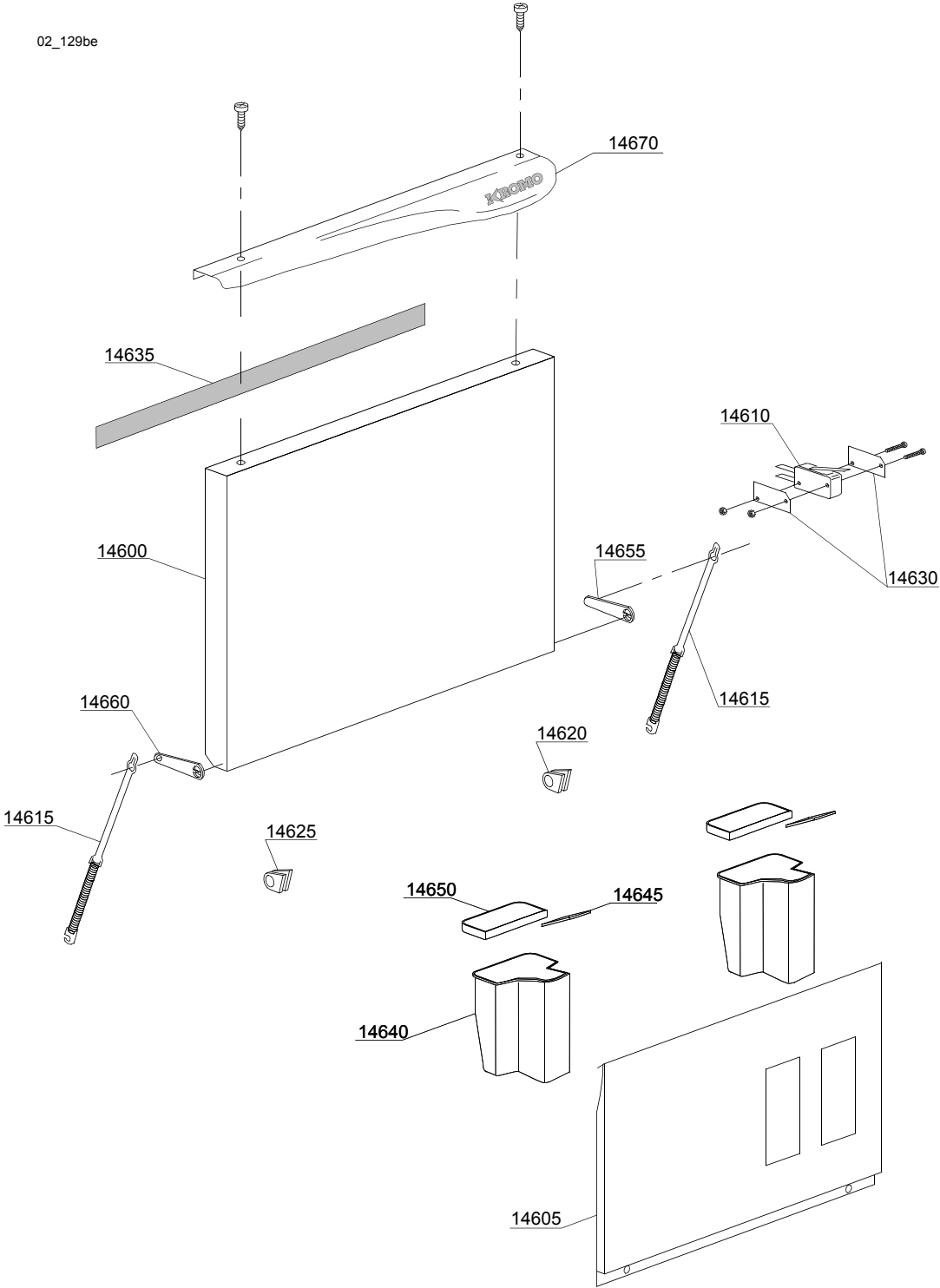

Spare parts

ID	P-code	SN from	SN to	Mod.	Acces.	Volt	Description
Module: Lockup system							
14600	540958		-				Door with steel handle
14605	540935		-				Lower door
14610	10704		-				Door microswitch
14615	560003		-				Door spring
14620	540035		-				Right axle bush for door hinge (minimum 2 pieces)
14625	540036		-				Left axle bush for door hinge (minimum 2 pieces)
14630	10770		-				Insulation for door microswitch (minimum 3 pieces)
14635	560021		-				Profile for door O-ring
14640	540050		-				Square tank
14645	540044		-				Shining product tank cover
14650	540049		-				Back tank cover
14655	540624		-				Right arm for door
14660	540629		-				Left arm for door
14670	540961		-				Steel handle

em=ELECTROMECHANICAL SWITCHES, e=ELECTRONICAL SWITCHES, lw=LOWER WASHING, uw=LOWER AND UPPER WASHING, i=INSULATED MODEL

LUX40EL=LUX40EL

bt=BREAK TANK, bp=BOOSTER PUMP, dvgw=DVGW, cr=COLD RINSE, ws=WATER SOFTNER, dd=DETERGENT DISPENSER, dp=DRAIN PUMP

A=3/N/PE~380-400V 50-60Hz, D=3/PE~200-210V 50-60Hz, F=2/PE~220-240V 50-60Hz, G=3/N/PE~415V 50-60Hz, H=3/PE~220-230V 50-60Hz, K=3/PE~380-400V 50-60Hz, L=3/PE~415V 50-60Hz, M=3/PE~440V 60Hz, P=1/N/PE~220-230V 50-60Hz, R=2/PE~220-240V 50-60Hz, U=1/N/PE~240V 50-60Hz, V=3/PE~240V 50-60Hz, W=1/N/PE~100-110V 50-60Hz

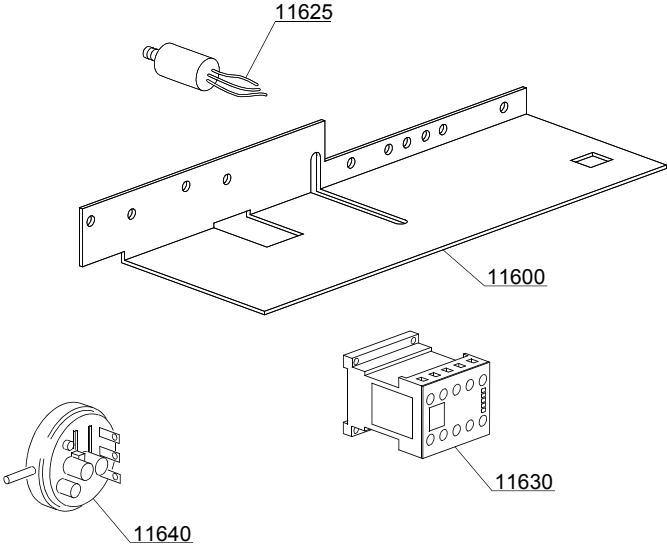

04_001fe

Spare parts

ID	P-code	SN from	SN to	Mod.	Acces.	Volt	Description
Module:Control panel and switches							
11600	540943		-	e			Electric components panel
11625	15149		-	e			Low noise filter
11630	15086		-	e			Contactactor 230V 50/60Hz 4C
11630	15086/B		-	e			Contactactor 240V 50Hz
11640	540450		-	e			"EL" 59-25 Work pressure switch

em=ELECTROMECHANICAL SWITCHES, e=ELECTRONICAL SWITCHES, lw=LOWER WASHING, uw=LOWER AND UPPER WASHING, i=INSULATED MODEL

LUX40EL=LUX40EL

bt=BREAK TANK, bp=BOOSTER PUMP, dvgw=DVGW, cr=COLD RINSE, ws=WATER SOFTNER, dd=DETERGENT DISPENSER, dp=DRAIN PUMP

A=3/N/PE~380-400V 50-60Hz, D=3/PE~200-210V 50-60Hz, F=2/PE~220-240V 50-60Hz, G=3/N/PE~415V 50-60Hz, H=3/PE~220-230V 50-60Hz, K=3/PE~380-400V 50-60Hz, L=3/PE~415V 50-60Hz, M=3/PE~440V 60Hz, P=1/N/PE~220-230V 50-60Hz, R=2/PE~220-240V 50-60Hz, U=1/N/PE~240V 50-60Hz, V=3/PE~240V 50-60Hz, W=1/N/PE~100-110V 50-60Hz

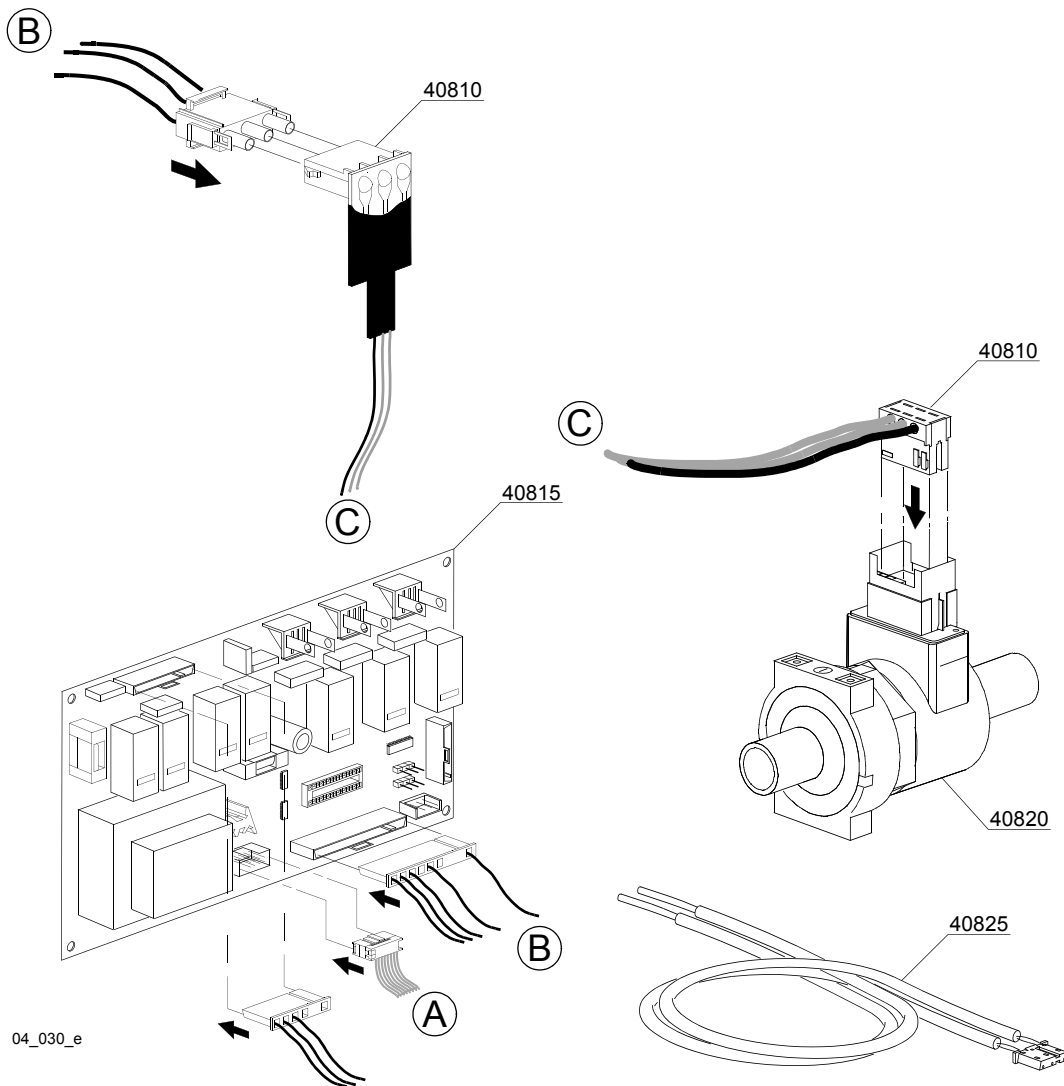
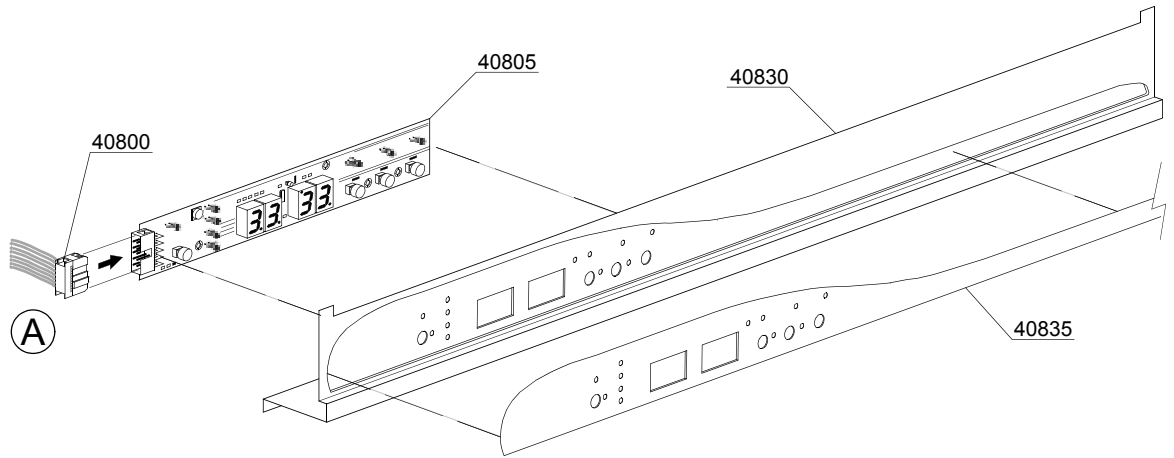

04_030_e

Spare parts

ID	P-code	SN from	SN to	Mod.	Acces.	Volt	Description
Module:Electric control							
40800	50589		-	i,e			Plug
40805	50581		-	i,e			Touche sensitive
40810	50584		-	i,e			Water flow board
40815	50580		-	i,e			Electronic timer+main board
40820	50583		-	i,e			Water flow meter for board
40825	50562		-	i,e			Temperature probe set
40830	540963		-	i,e			Control Panel
40835	540964		-	i,e			Silkscreen processed grill

em=ELECTROMECHANICAL SWITCHES, e=ELECTRONICAL SWITCHES, lw=LOWER WASHING, uw=LOWER AND UPPER WASHING, i=INSULATED MODEL

LUX40EL=LUX40EL

bt=BREAK TANK, bp=BOOSTER PUMP, dvgw=DVGW, cr=COLD RINSE, ws=WATER SOFTNER, dd=DETERGENT DISPENSER, dp=DRAIN PUMP

A=3/N/PE~380-400V 50-60Hz, D=3/PE~200-210V 50-60Hz, F=2/PE~220-240V 50-60Hz, G=3/N/PE~415V 50-60Hz, H=3/PE~220-230V 50-60Hz, K=3/PE~380-400V 50-60Hz, L=3/PE~415V 50-60Hz, M=3/PE~440V 60Hz, P=1/N/PE~220-230V 50-60Hz, R=2/PE~220-240V 50-60Hz, U=1/N/PE~240V 50-60Hz, V=3/PE~240V 50-60Hz, W=1/N/PE~100-110V 50-60Hz

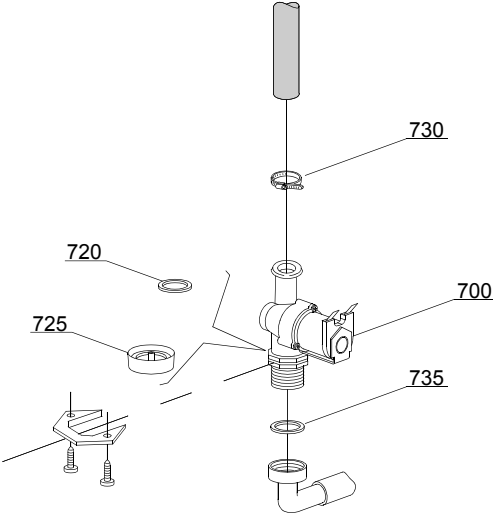

05_002_e

Spare parts

ID	P-code	SN from	SN to	Mod.	Acces.	Volt	Description
Module:Solenoid valve group							
700	10703		-	i,em,e			Single solenoid valve - 230Vac
700	10703/A		-	i,em,e			Single solenoid valve - 110Vac
720	N.C.		-	i,em,e			Pression reducing valve
730	11807		-	i,em,e			12/22 clamp (minimum 3 pieces)
735	13307		-	i,em,e			3/4 gasket

em=ELECTROMECHANICAL SWITCHES, e=ELECTRONICAL SWITCHES, lw=LOWER WASHING, uw=LOWER AND UPPER WASHING, i=INSULATED MODEL

LUX40EL=LUX40EL

bt=BREAK TANK, bp=BOOSTER PUMP, dvgw=DVGW, cr=COLD RINSE, ws=WATER SOFTNER, dd=DETERGENT DISPENSER, dp=DRAIN PUMP

A=3/N/PE~380-400V 50-60Hz, D=3/PE~200-210V 50-60Hz, F=2/PE~220-240V 50-60Hz, G=3/N/PE~415V 50-60Hz, H=3/PE~220-230V 50-60Hz, K=3/PE~380-400V 50-60Hz, L=3/PE~415V 50-60Hz, M=3/PE~440V 60Hz, P=1/N/PE~220-230V 50-60Hz, R=2/PE~220-240V 50-60Hz, U=1/N/PE~240V 50-60Hz, V=3/PE~240V 50-60Hz, W=1/N/PE~100-110V 50-60Hz

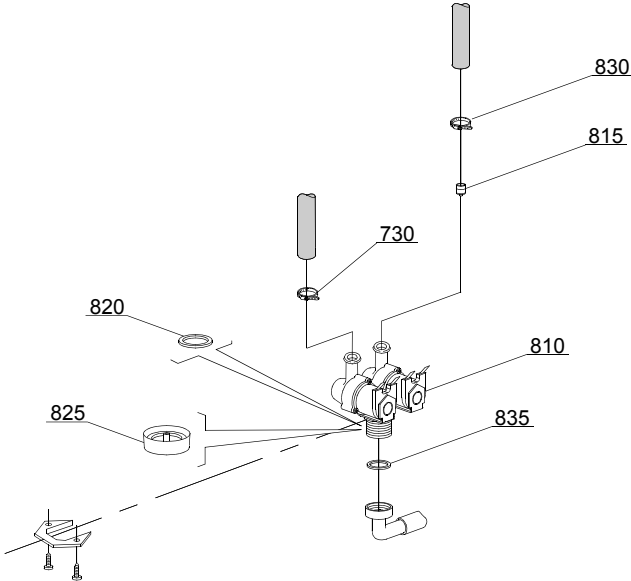

05_003_€

Spare parts

ID	P-code	SN from	SN to	Mod.	Acces.	Volt	Description
Module:Solenoid valve group							
810	15098		-	i,em,e	cr,ws		Double solenoid valve - Ø10 - 230Vac
815	15115		-	e,i,em	cr,ws		Green pression solenoid valve for regeneration (minimum 2 pieces)
820	N.C.		-	e,i,em	cr,ws		Pression reducing valve
830	11807		-	i,em,e			12/22 clamp (minimum 3 pieces)
835	13307		-	i,em,e			3/4 gasket

em=ELECTROMECHANICAL SWITCHES, e=ELECTRONICAL SWITCHES, lw=LOWER WASHING, uw=LOWER AND UPPER WASHING, i=INSULATED MODEL

LUX40EL=LUX40EL

bt=BREAK TANK, bp=BOOSTER PUMP, dvgw=DVGW, cr=COLD RINSE, ws=WATER SOFTNER, dd=DETERGENT DISPENSER, dp=DRAIN PUMP

A=3/N/PE~380-400V 50-60Hz, D=3/PE~200-210V 50-60Hz, F=2/PE~220-240V 50-60Hz, G=3/N/PE~415V 50-60Hz, H=3/PE~220-230V 50-60Hz, K=3/PE~380-400V 50-60Hz, L=3/PE~415V 50-60Hz, M=3/PE~440V 60Hz, P=1/N/PE~220-230V 50-60Hz, R=2/PE~220-240V 50-60Hz, U=1/N/PE~240V 50-60Hz, V=3/PE~240V 50-60Hz, W=1/N/PE~100-110V 50-60Hz

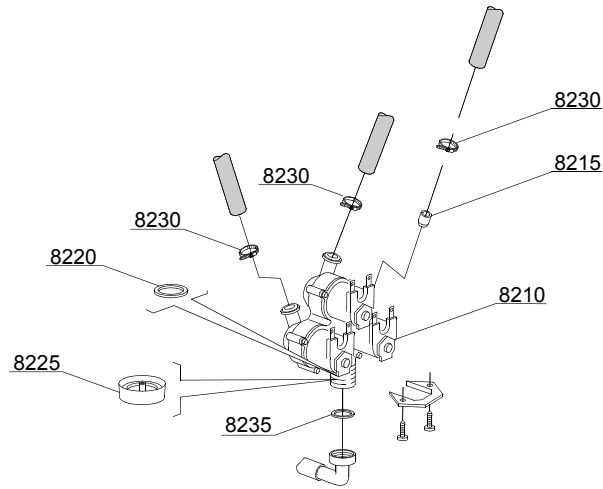

05_004_ε

Spare parts

ID	P-code	SN from	SN to	Mod.	Acces.	Volt	Description
Module:Solenoid valve group							
8210	15099		-		cr,ws		Triple solenoid valve
8215	15115		-		cr,ws		Green pression solenoid valve (minimum 2 pieces)
8220	N.C.		-		cr,ws		Pression reducing valve
8230	11807		-	i,em,e			12/22 clamp (minimum 3 pieces)
8235	13307		-	i,em,e			3/4 gasket

em=ELECTROMECHANICAL SWITCHES, e=ELECTRONICAL SWITCHES, lw=LOWER WASHING, uw=LOWER AND UPPER WASHING, i=INSULATED MODEL

LUX40EL=LUX40EL

bt=BREAK TANK, bp=BOOSTER PUMP, dvgw=DVGW, cr=COLD RINSE, ws=WATER SOFTNER, dd=DETERGENT DISPENSER, dp=DRAIN PUMP

A=3/N/PE~380-400V 50-60Hz, D=3/PE~200-210V 50-60Hz, F=2/PE~220-240V 50-60Hz, G=3/N/PE~415V 50-60Hz, H=3/PE~220-230V 50-60Hz, K=3/PE~380-400V 50-60Hz, L=3/PE~415V 50-60Hz, M=3/PE~440V 60Hz, P=1/N/PE~220-230V 50-60Hz, R=2/PE~220-240V 50-60Hz, U=1/N/PE~240V 50-60Hz, V=3/PE~240V 50-60Hz, W=1/N/PE~100-110V 50-60Hz

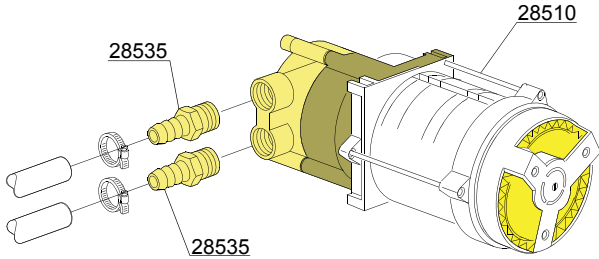
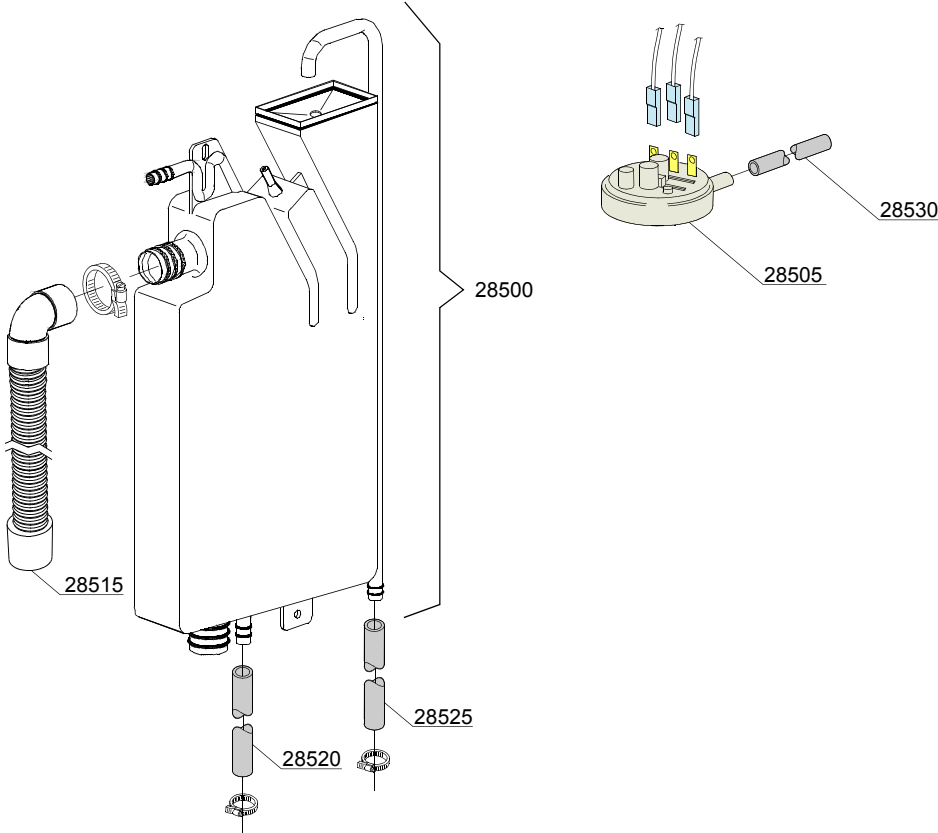

06_004pe

Spare parts

ID	P-code	SN from	SN to	Mod.	Acces.	Volt	Description
Module:Break Tank							
28500	15735		-	i,em,e	bt		Break tank assembly
28505	10706/A		-	i,em,e	bt		47-27 pressure switch
28510	15100/D		-	i,em,e	bt		Booster pump 220/240V
28515	15721		-	i,em,e	bt		BT long pipe L=1070
28515	15722		-	i,em,e	bt		BT middle pipe L=920
28515	15723		-	i,em,e	bt		BT small pipe L=690
28520	2907350		-	i,em,e	bt		12x20 EPDM rubber hose
28525	2907352		-	i,em,e	bt		PVC WRAS rubber hose
28530	14508		-	i,em,e	bt		4,5x9 EPDM rubber hose (minimum 2 mt)
28535	12013		-	i,em,e	bt		Rubber-holder

em=ELECTROMECHANICAL SWITCHES, e=ELECTRONICAL SWITCHES, lw=LOWER WASHING, uw=LOWER AND UPPER WASHING, i=INSULATED MODEL

LUX40EL=LUX40EL

bt=BREAK TANK, bp=BOOSTER PUMP, dvgw=DVGW, cr=COLD RINSE, ws=WATER SOFTNER, dd=DETERGENT DISPENSER, dp=DRAIN PUMP

A=3/N/PE~380-400V 50-60Hz, D=3/PE~200-210V 50-60Hz, F=2/PE~220-240V 50-60Hz, G=3/N/PE~415V 50-60Hz, H=3/PE~220-230V 50-60Hz, K=3/PE~380-400V 50-60Hz, L=3/PE~415V 50-60Hz, M=3/PE~440V 60Hz, P=1/N/PE~220-230V 50-60Hz, R=2/PE~220-240V 50-60Hz, U=1/N/PE~240V 50-60Hz, V=3/PE~240V 50-60Hz, W=1/N/PE~100-110V 50-60Hz

07_003ae

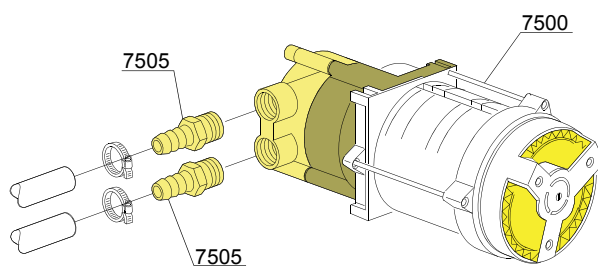

VERSIONE STANDARD / VERSIONE POMPA AUM. PRESSIONE
STANDARD VERSION / BOOSTER PUMP VERSION
VERSION STANDARD / VERSION POMPE AUGMENT. PRESSION

Spare parts

ID	P-code	SN from	SN to	Mod.	Acces.	Volt	Description
Module:Booster pump							
7500	15100/D		-	e,i,em	bp		Booster pump 220/240V - body pumps in plastic
7505	10221311		-	e,i,em	bp		Rubber holder Ø 12 3/8G

em=ELECTROMECHANICAL SWITCHES, e=ELECTRONICAL SWITCHES, lw=LOWER WASHING, uw=LOWER AND UPPER WASHING, i=INSULATED MODEL

LUX40EL=LUX40EL

bt=BREAK TANK, bp=BOOSTER PUMP, dvgw=DVGW, cr=COLD RINSE, ws=WATER SOFTNER, dd=DETERGENT DISPENSER, dp=DRAIN PUMP

A=3/N/PE~380-400V 50-60Hz, D=3/PE~200-210V 50-60Hz, F=2/PE~220-240V 50-60Hz, G=3/N/PE~415V 50-60Hz, H=3/PE~220-230V 50-60Hz, K=3/PE~380-400V 50-60Hz, L=3/PE~415V 50-60Hz, M=3/PE~440V 60Hz, P=1/N/PE~220-230V 50-60Hz, R=2/PE~220-240V 50-60Hz, U=1/N/PE~240V 50-60Hz, V=3/PE~240V 50-60Hz, W=1/N/PE~100-110V 50-60Hz

08_005_e

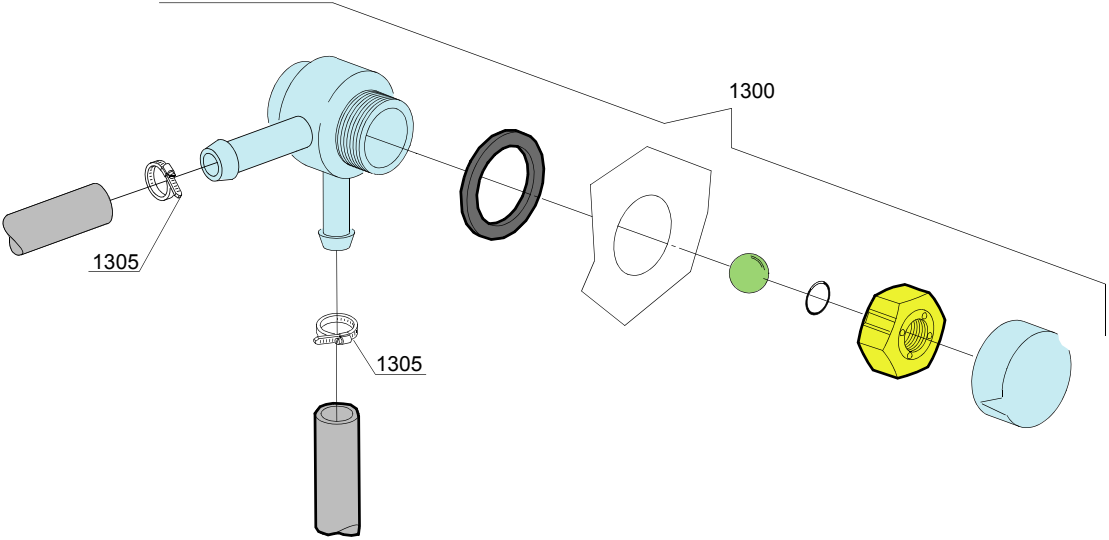

Spare parts

ID	P-code	SN from	SN to	Mod.	Acces.	Volt	Description
Module:DVGW							
1300	999900006		-		dvgw		DVGW assembly
1305	11807		-				12/22 clamp (minimum 3 pieces)

em=ELECTROMECHANICAL SWITCHES, e=ELECTRONICAL SWITCHES, lw=LOWER WASHING, uw=LOWER AND UPPER WASHING, i=INSULATED MODEL

LUX40EL=LUX40EL

bt=BREAK TANK, bp=BOOSTER PUMP, dvgw=DVGW, cr=COLD RINSE, ws=WATER SOFTNER, dd=DETERGENT DISPENSER, dp=DRAIN PUMP

A=3/N/PE~380-400V 50-60Hz, D=3/PE~200-210V 50-60Hz, F=2/PE~220-240V 50-60Hz, G=3/N/PE~415V 50-60Hz, H=3/PE~220-230V 50-60Hz, K=3/PE~380-400V 50-60Hz, L=3/PE~415V 50-60Hz, M=3/PE~440V 60Hz, P=1/N/PE~220-230V 50-60Hz, R=2/PE~220-240V 50-60Hz, U=1/N/PE~240V 50-60Hz, V=3/PE~240V 50-60Hz, W=1/N/PE~100-110V 50-60Hz

09_001_e

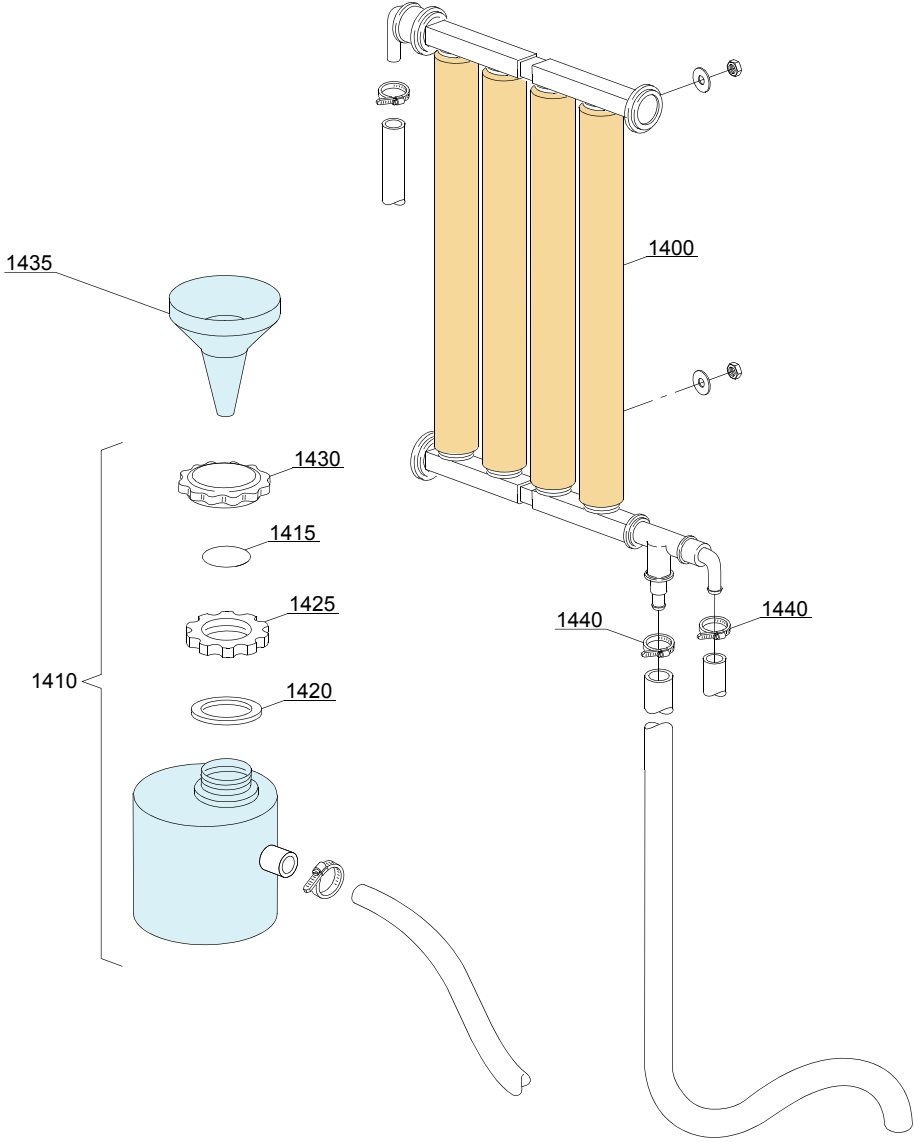

Spare parts

ID	P-code	SN from	SN to	Mod.	Acces.	Volt	Description
Module: Water softner group							
1400	16066		-	e,em	ws		4 elements water softner
1410	16065		-	e,em	ws		Salt container
1415	16067/A		-	e,em	ws		OR O-ring
1420	16067/B		-	e,em	ws		O-ring
1425	16067/C		-	e,em	ws		Ring nut
1430	16067/D		-	e,em	ws		Plug
1435	16082		-	e,em	ws		Funnel
1440	11807		-	e,em	ws		12/22 clamp (minimum 3 pieces)

em=ELECTROMECHANICAL SWITCHES, e=ELECTRONICAL SWITCHES, lw=LOWER WASHING, uw=LOWER AND UPPER WASHING, i=INSULATED MODEL

LUX40EL=LUX40EL

bt=BREAK TANK, bp=BOOSTER PUMP, dvgw=DVGW, cr=COLD RINSE, ws=WATER SOFTNER, dd=DETERGENT DISPENSER, dp=DRAIN PUMP

A=3/N/PE~380-400V 50-60Hz, D=3/PE~200-210V 50-60Hz, F=2/PE~220-240V 50-60Hz, G=3/N/PE~415V 50-60Hz, H=3/PE~220-230V 50-60Hz, K=3/PE~380-400V 50-60Hz, L=3/PE~415V 50-60Hz, M=3/PE~440V 60Hz, P=1/N/PE~220-230V 50-60Hz, R=2/PE~220-240V 50-60Hz, U=1/N/PE~240V 50-60Hz, V=3/PE~240V 50-60Hz, W=1/N/PE~100-110V 50-60Hz

10_001be

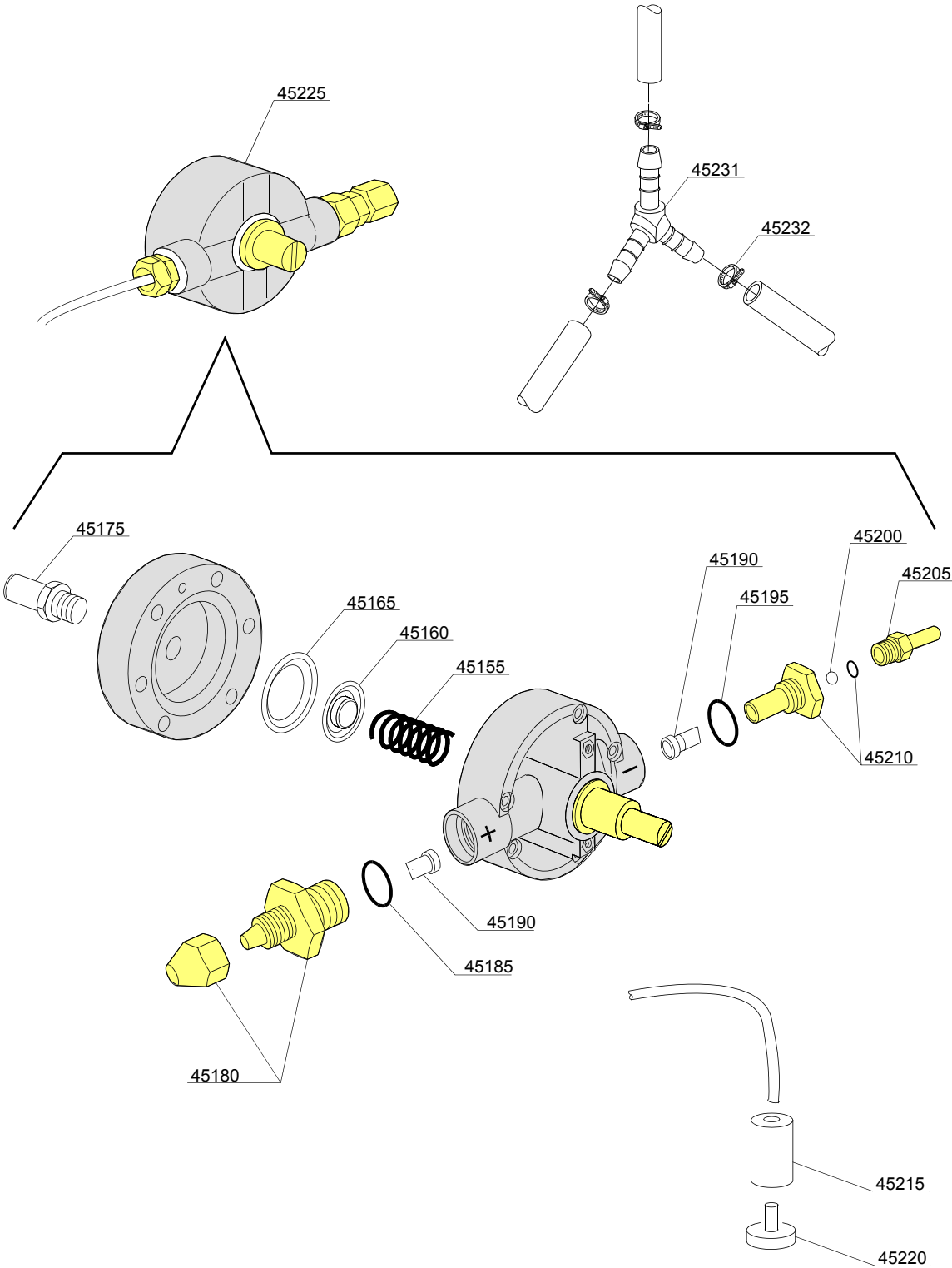

Spare parts

ID	P-code	SN from	SN to	Mod.	Acces.	Volt	Description
Module: Rinse aid dispenser group							
45155	10705/M		-	e,i,em			Spring
45160	10705/N		-	e,i,em			Disc to membrane
45165	10750/O		-	e,i,em			Membrane
45175	12506		-	e,i,em			Rubber-holder Ø 10mm
45180	10705/G		-	e,i,em			Pipe fitting
45185	10705/C		-	e,i,em			OR-gasket
45190	10705/D		-	e,i,em			Silicone valve
45195	10705/C		-	e,i,em			OR-gasket
45200	10705/T		-	e,i,em			Sphere made of Teflon
45205	10705/R		-	e,i,em			Brass pipe fitting
45210	10705/E		-	e,i,em			OR-gasket Guide valve
45215	12525		-	e,i,em			Ballast
45220	15058		-	e,i,em			Small filter (minimum 3 pieces)
45225	10799/G		-	e,i,em			GERMAC rinse aid dispenser
45231	540091		-	e,i,em			Ø12 mm plastic 3 ways connection
45232	11807		-	e,i,em			Clamp 12-22 (minimum 3 pieces)

em=ELECTROMECHANICAL SWITCHES, e=ELECTRONICAL SWITCHES, lw=LOWER WASHING, uw=LOWER AND UPPER WASHING, i=INSULATED MODEL

LUX40EL=LUX40EL

bt=BREAK TANK, bp=BOOSTER PUMP, dvgw=DVGW, cr=COLD RINSE, ws=WATER SOFTNER, dd=DETERGENT DISPENSER, dp=DRAIN PUMP

A=3/N/PE~380-400V 50-60Hz, D=3/PE~200-210V 50-60Hz, F=2/PE~220-240V 50-60Hz, G=3/N/PE~415V 50-60Hz, H=3/PE~220-230V 50-60Hz, K=3/PE~380-400V 50-60Hz, L=3/PE~415V 50-60Hz, M=3/PE~440V 60Hz, P=1/N/PE~220-230V 50-60Hz, R=2/PE~220-240V 50-60Hz, U=1/N/PE~240V 50-60Hz, V=3/PE~240V 50-60Hz, W=1/N/PE~100-110V 50-60Hz

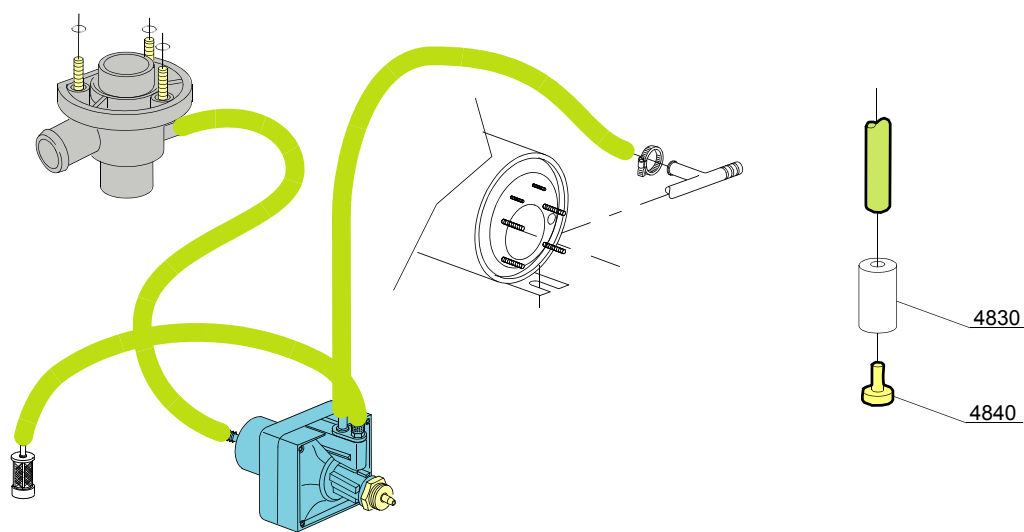
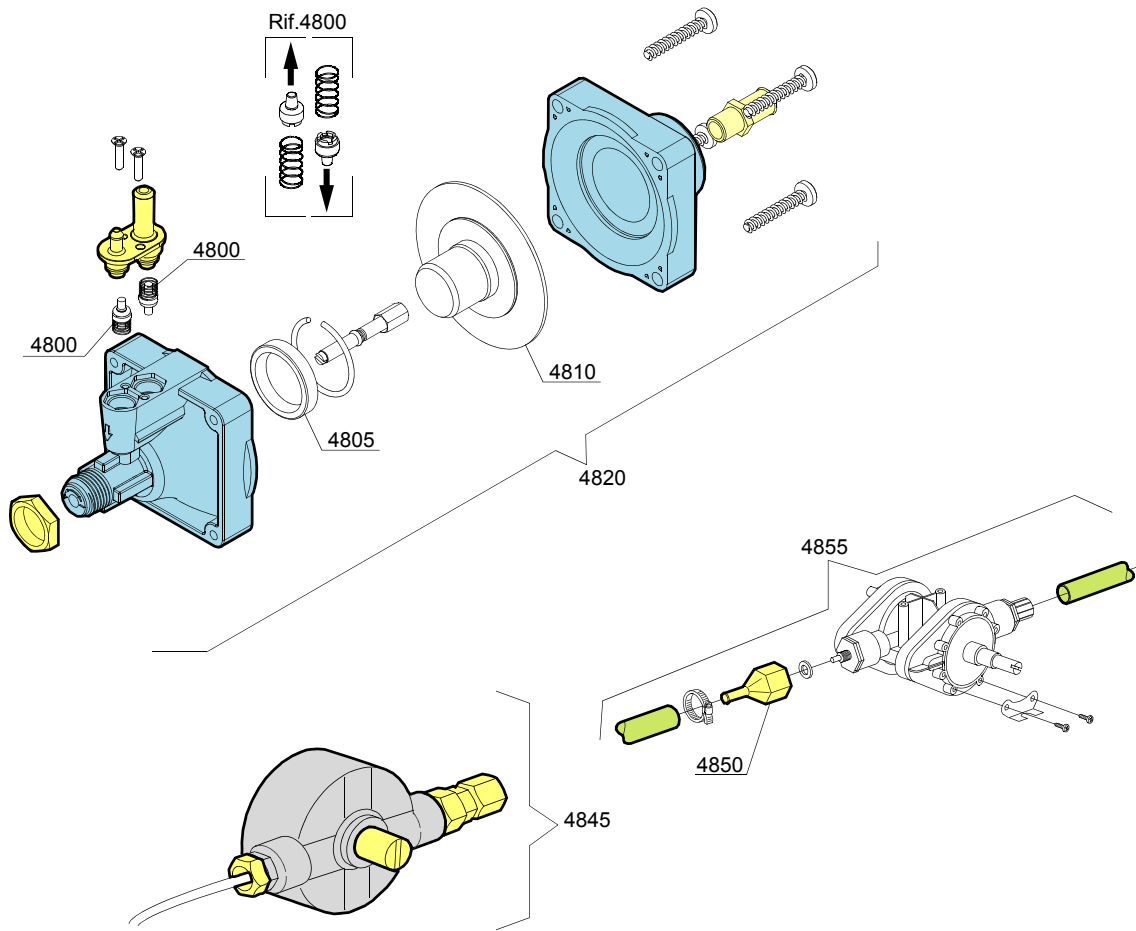

10_004_e

Spare parts

ID	P-code	SN from	SN to	Mod.	Acces.	Volt	Description
Module: Rinse aid dispenser group							
4800	10805		-	e,em			Tecnopro non return valve
4805	10806		-	e,em			Ø22 O-ring
4810	10807		-	e,em			Membrane
4820	10799		-	e,em			TECNO PRO rinse aid dispenser
4830	12525		-	e,em			Ballast
4840	15058		-	e,em			Small filter (minimum 3 pieces)
4845	10799/G		-	e,em			GERMAC rinse aid dispenser
4850	10798/B		-	e,em			Brass pipe fitting
4855	10798		-	e,em			LANG Rinse aid dispenser

em=ELECTROMECHANICAL SWITCHES, e=ELECTRONICAL SWITCHES, lw=LOWER WASHING, uw=LOWER AND UPPER WASHING, i=INSULATED MODEL

LUX40EL=LUX40EL

bt=BREAK TANK, bp=BOOSTER PUMP, dvgw=DVGW, cr=COLD RINSE, ws=WATER SOFTNER, dd=DETERGENT DISPENSER, dp=DRAIN PUMP

A=3/N/PE~380-400V 50-60Hz, D=3/PE~200-210V 50-60Hz, F=2/PE~220-240V 50-60Hz, G=3/N/PE~415V 50-60Hz, H=3/PE~220-230V 50-60Hz, K=3/PE~380-400V 50-60Hz, L=3/PE~415V 50-60Hz, M=3/PE~440V 60Hz, P=1/N/PE~220-230V 50-60Hz, R=2/PE~220-240V 50-60Hz, U=1/N/PE~240V 50-60Hz, V=3/PE~240V 50-60Hz, W=1/N/PE~100-110V 50-60Hz

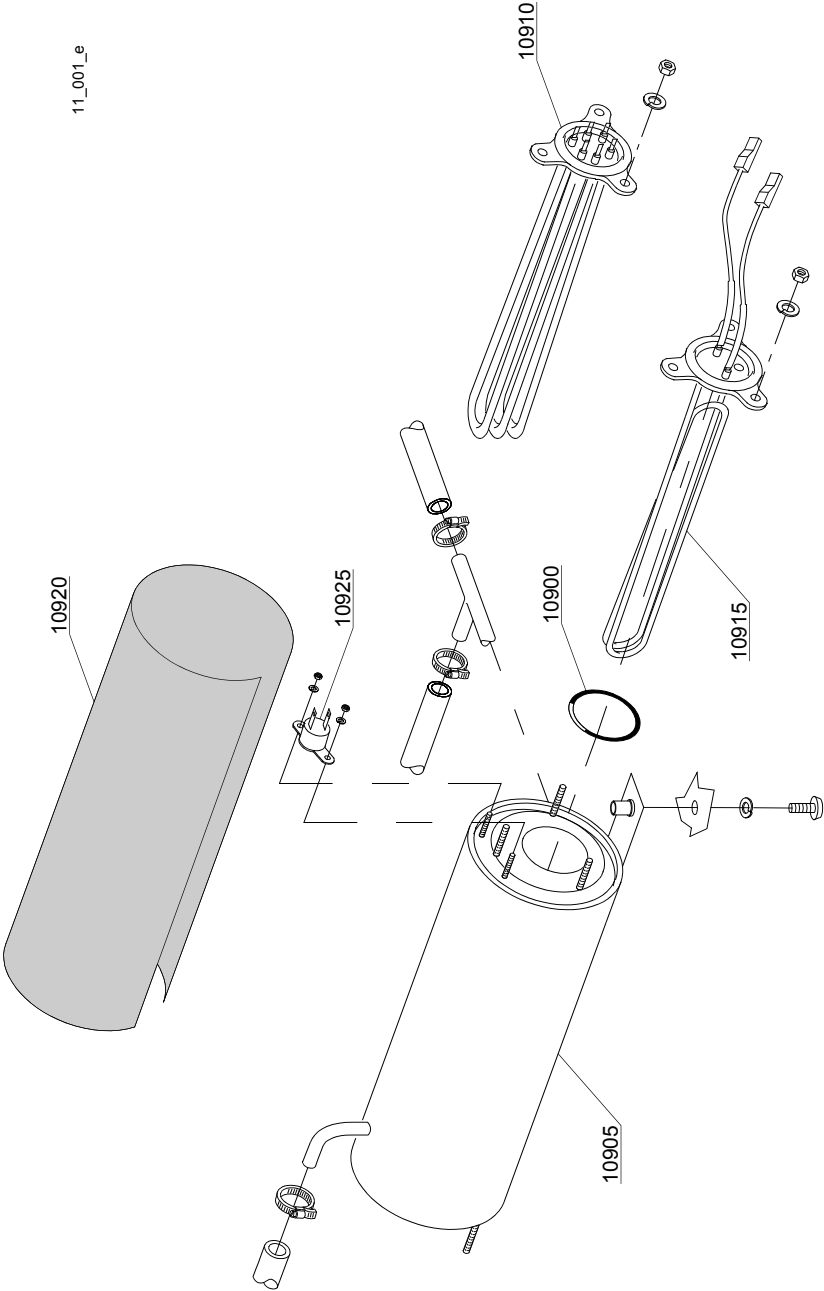

Spare parts

ID	P-code	SN from	SN to	Mod.	Acces.	Volt	Description
Module:Boiler group							
10900	13010		-				OR O-ring (minimum 5 pieces)
10905	540006		-				Boiler
10910	18215		-				4/4,36KW 230/240V 3 heating element
10915	18206/D		-				2,8/3,05KW 230/240V heating element
10915	18206		-				2,4/2,61KW 230/240V heating element
10920	540040		-				Insulation boiler
10925	15550		-				Safety thermostat

em=ELECTROMECHANICAL SWITCHES, e=ELECTRONICAL SWITCHES, lw=LOWER WASHING, uw=LOWER AND UPPER WASHING, i=INSULATED MODEL

LUX40EL=LUX40EL

bt=BREAK TANK, bp=BOOSTER PUMP, dvgw=DVGW, cr=COLD RINSE, ws=WATER SOFTNER, dd=DETERGENT DISPENSER, dp=DRAIN PUMP

A=3/N/PE~380-400V 50-60Hz, D=3/PE~200-210V 50-60Hz, F=2/PE~220-240V 50-60Hz, G=3/N/PE~415V 50-60Hz, H=3/PE~220-230V 50-60Hz, K=3/PE~380-400V 50-60Hz, L=3/PE~415V 50-60Hz, M=3/PE~440V 60Hz, P=1/N/PE~220-230V 50-60Hz, R=2/PE~220-240V 50-60Hz, U=1/N/PE~240V 50-60Hz, V=3/PE~240V 50-60Hz, W=1/N/PE~100-110V 50-60Hz

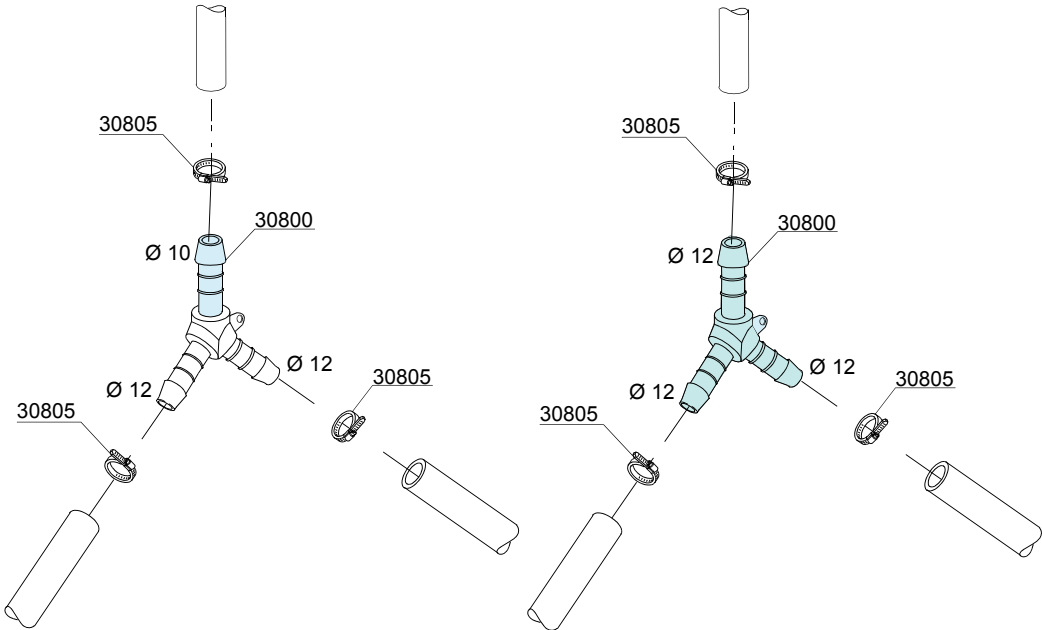

12_003ae

Spare parts

ID	P-code	SN from	SN to	Mod.	Acces.	Volt	Description
Module:3 ways connection							
30800	540090		-	e,i,em			Ø10 mm plastic 3 ways connection
30805	11807		-	e,i,em			12/22 clamp (minimum 3 pieces)

em=ELECTROMECHANICAL SWITCHES, e=ELECTRONICAL SWITCHES, lw=LOWER WASHING, uw=LOWER AND UPPER WASHING, i=INSULATED MODEL

LUX40EL=LUX40EL

bt=BREAK TANK, bp=BOOSTER PUMP, dvgw=DVGW, cr=COLD RINSE, ws=WATER SOFTNER, dd=DETERGENT DISPENSER, dp=DRAIN PUMP

A=3/N/PE~380-400V 50-60Hz, D=3/PE~200-210V 50-60Hz, F=2/PE~220-240V 50-60Hz, G=3/N/PE~415V 50-60Hz, H=3/PE~220-230V 50-60Hz, K=3/PE~380-400V 50-60Hz, L=3/PE~415V 50-60Hz, M=3/PE~440V 60Hz, P=1/N/PE~220-230V 50-60Hz, R=2/PE~220-240V 50-60Hz, U=1/N/PE~240V 50-60Hz, V=3/PE~240V 50-60Hz, W=1/N/PE~100-110V 50-60Hz

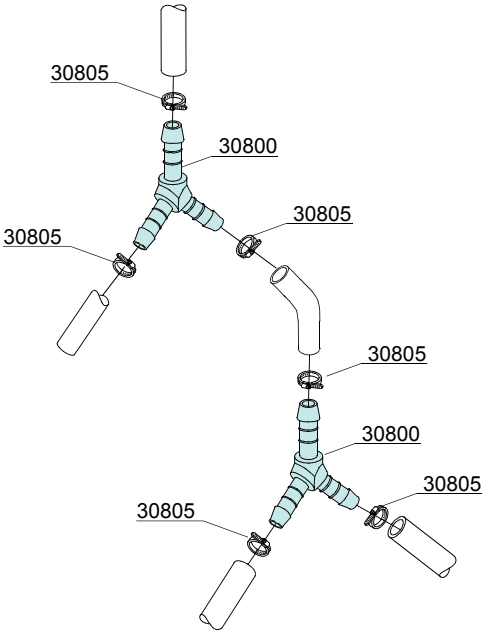

12_010_e

Spare parts

ID	P-code	SN from	SN to	Mod.	Acces.	Volt	Description
Module:3 ways connection							
30800	540090		-	e,i,em	cr		Ø10 mm plastic 3 ways connection
30805	11807		-	e,i,em	cr		12/22 clamp (minimum 3 pieces)

em=ELECTROMECHANICAL SWITCHES, e=ELECTRONICAL SWITCHES, lw=LOWER WASHING, uw=LOWER AND UPPER WASHING, i=INSULATED MODEL

LUX40EL=LUX40EL

bt=BREAK TANK, bp=BOOSTER PUMP, dvgw=DVGW, cr=COLD RINSE, ws=WATER SOFTNER, dd=DETERGENT DISPENSER, dp=DRAIN PUMP

A=3/N/PE~380-400V 50-60Hz, D=3/PE~200-210V 50-60Hz, F=2/PE~220-240V 50-60Hz, G=3/N/PE~415V 50-60Hz, H=3/PE~220-230V 50-60Hz, K=3/PE~380-400V 50-60Hz, L=3/PE~415V 50-60Hz, M=3/PE~440V 60Hz, P=1/N/PE~220-230V 50-60Hz, R=2/PE~220-240V 50-60Hz, U=1/N/PE~240V 50-60Hz, V=3/PE~240V 50-60Hz, W=1/N/PE~100-110V 50-60Hz

13_001_e

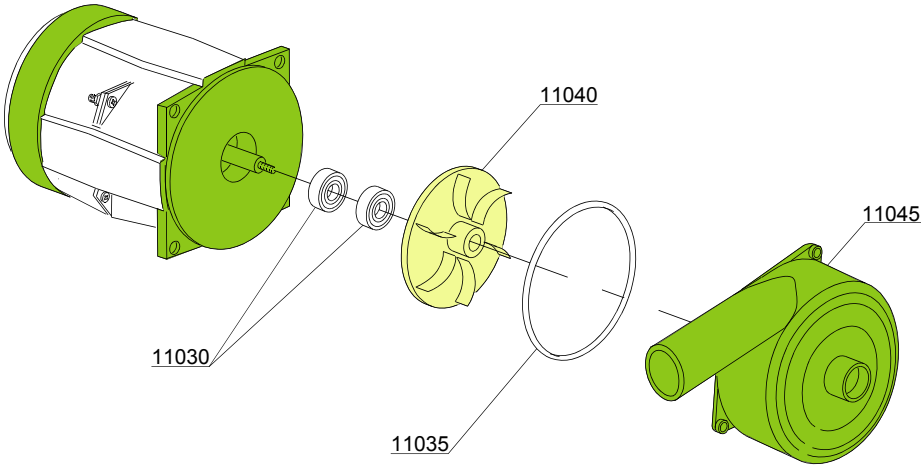
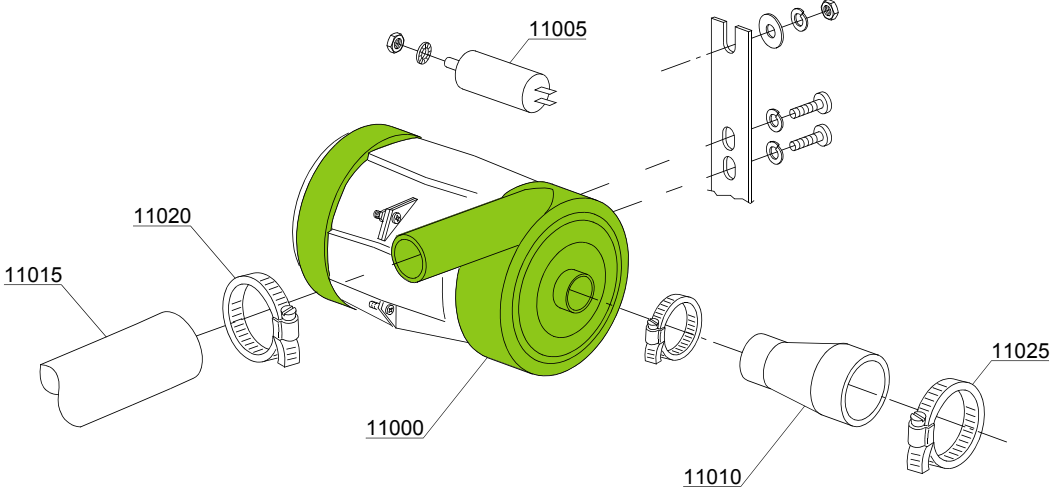

Spare parts

ID	P-code	SN from	SN to	Mod.	Acces.	Volt	Description
Module: Wash pump							
11000	18243		-	lw		A	"CF" 0,33Hp wash pump - 230V 50Hz
11005	18043		-	lw			10 uF condenser
11010	540005		-	lw			Suction pipe coupling
11015	16168		-	lw			Lower wash delivery pipe
11020	11806		-	lw			25/40 clamp (minimum 2 pieces)
11025	11824		-	lw			50/70 clamp (minimum 2 pieces)
11030	15080		-	lw			Rotating seals
11035	18245		-	lw			OR O-ring
11040	18246		-	lw			Pump rotor
11045	18248		-	lw			Scroll

em=ELECTROMECHANICAL SWITCHES, e=ELECTRONICAL SWITCHES, lw=LOWER WASHING, uw=LOWER AND UPPER WASHING, i=INSULATED MODEL

LUX40EL=LUX40EL

bt=BREAK TANK, bp=BOOSTER PUMP, dvgw=DVGW, cr=COLD RINSE, ws=WATER SOFTNER, dd=DETERGENT DISPENSER, dp=DRAIN PUMP

A=3/N/PE~380-400V 50-60Hz, D=3/PE~200-210V 50-60Hz, F=2/PE~220-240V 50-60Hz, G=3/N/PE~415V 50-60Hz, H=3/PE~220-230V 50-60Hz, K=3/PE~380-400V 50-60Hz, L=3/PE~415V 50-60Hz, M=3/PE~440V 60Hz, P=1/N/PE~220-230V 50-60Hz, R=2/PE~220-240V 50-60Hz, U=1/N/PE~240V 50-60Hz, V=3/PE~240V 50-60Hz, W=1/N/PE~100-110V 50-60Hz

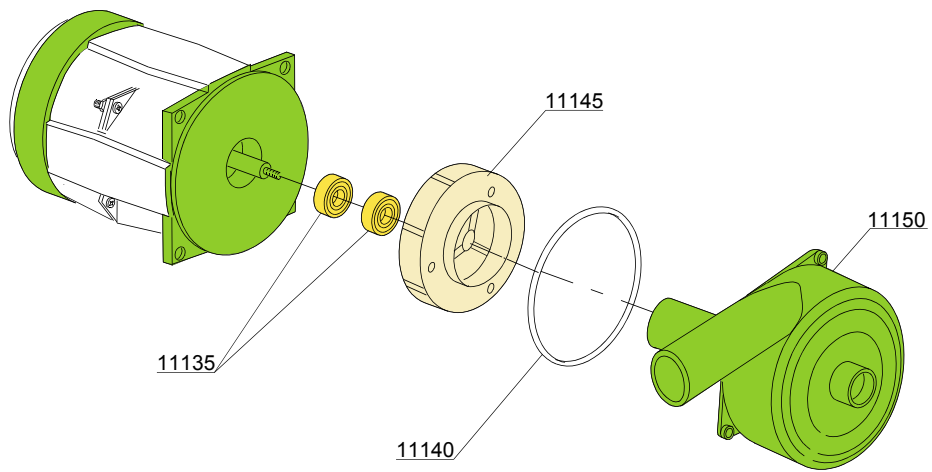
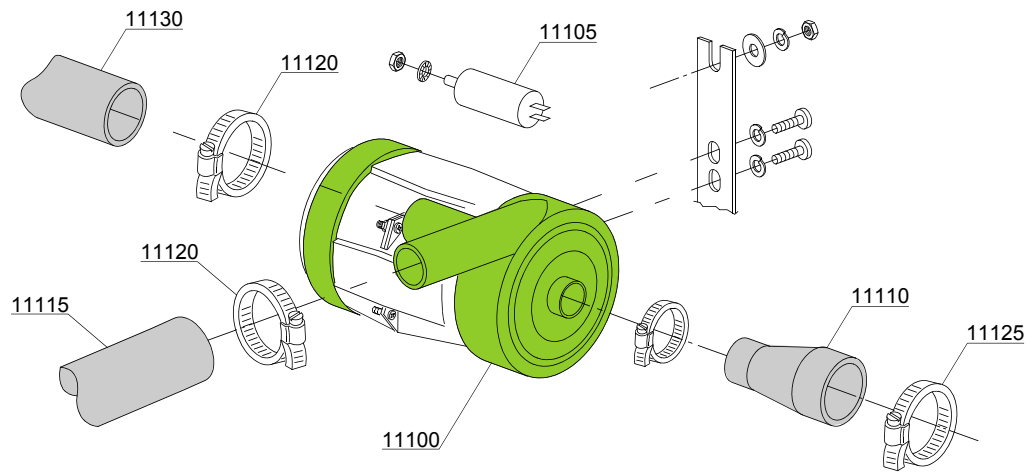

13_101_e

Spare parts

ID	P-code	SN from	SN to	Mod.	Acces.	Volt	Description
Module: Wash pump							
11100	18242		-	uw		A	0,30Hp wash pump - 230V
11100	18242/D		-	uw		A	0,30Hp wash pump - 220V 60Hz
11105	18043		-	uw			10 uF condenser
11110	540005		-	uw			Suction pipe coupling
11115	16168		-	uw			Lower wash delivery pipe
11120	11806		-	uw			25/40 clamp (minimum 2 pieces)
11125	11824		-	uw			50/70 clamp (minimum 2 pieces)
11130	540004		-	uw			Top delivery pipe
11135	15080		-	uw			Rotating seals
11140	18245		-	uw			OR O-ring
11145	18246		-	uw			Pump rotor
11150	18247		-	uw			Scroll

em=ELECTROMECHANICAL SWITCHES, e=ELECTRONICAL SWITCHES, lw=LOWER WASHING, uw=LOWER AND UPPER WASHING, i=INSULATED MODEL

LUX40EL=LUX40EL

bt=BREAK TANK, bp=BOOSTER PUMP, dvgw=DVGW, cr=COLD RINSE, ws=WATER SOFTNER, dd=DETERGENT DISPENSER, dp=DRAIN PUMP

A=3/N/PE~380-400V 50-60Hz, D=3/PE~200-210V 50-60Hz, F=2/PE~220-240V 50-60Hz, G=3/N/PE~415V 50-60Hz, H=3/PE~220-230V 50-60Hz, K=3/PE~380-400V 50-60Hz, L=3/PE~415V 50-60Hz, M=3/PE~440V 60Hz, P=1/N/PE~220-230V 50-60Hz, R=2/PE~220-240V 50-60Hz, U=1/N/PE~240V 50-60Hz, V=3/PE~240V 50-60Hz, W=1/N/PE~100-110V 50-60Hz

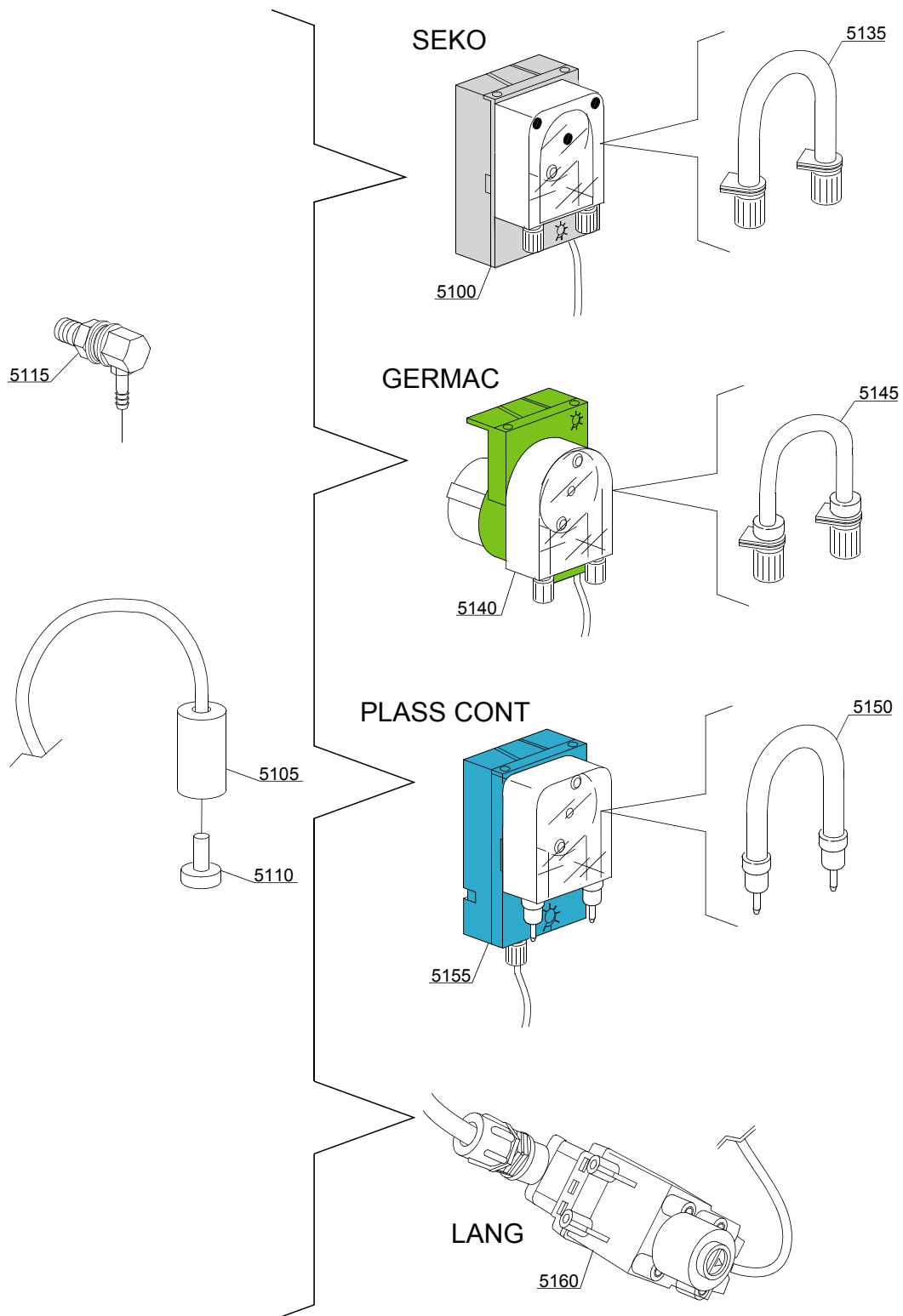

14_004_e

Spare parts

ID	P-code	SN from	SN to	Mod.	Acces.	Volt	Description
Module:Dosing detergent group							
5100	15985		-	i,em,e	dd		Seko detergent pump
5105	12525		-	i,em,e	dd		Ballast
5110	15058		-	i,em,e	dd		Small filter (minimum 3 pieces)
5120	15123		-	i,em,e	dd		Steel injector
5125	15159		-	i,em,e	dd		OR O-ring (minimum 2 pieces)
5130	10200205		-	i,em,e	dd		M12x1 stainless steel nut (minimum 2 pieces)
5135	15185		-	i,em,e	dd		Seko thermoplastic pipe
5140	15985		-	i,em,e	dd		Germac detergent pump
5145	15108/E		-	i,em,e	dd		Germac thermoplastic pipe
5150	15985/A			i,em,e	dd		Plas Cont thermoplastic pipe
5155	15985			i,em,e	dd		Plas Cont detergent pump
5160	15108/L			i,em,e	dd		Lang detergent pump

em=ELECTROMECHANICAL SWITCHES, e=ELECTRONICAL SWITCHES, lw=LOWER WASHING, uw=LOWER AND UPPER WASHING, i=INSULATED MODEL

LUX40EL=LUX40EL

bt=BREAK TANK, bp=BOOSTER PUMP, dvgw=DVGW, cr=COLD RINSE, ws=WATER SOFTNER, dd=DETERGENT DISPENSER, dp=DRAIN PUMP

A=3/N/PE~380-400V 50-60Hz, D=3/PE~200-210V 50-60Hz, F=2/PE~220-240V 50-60Hz, G=3/N/PE~415V 50-60Hz, H=3/PE~220-230V 50-60Hz, K=3/PE~380-400V 50-60Hz, L=3/PE~415V 50-60Hz, M=3/PE~440V 60Hz, P=1/N/PE~220-230V 50-60Hz, R=2/PE~220-240V 50-60Hz, U=1/N/PE~240V 50-60Hz, V=3/PE~240V 50-60Hz, W=1/N/PE~100-110V 50-60Hz

15_002_e

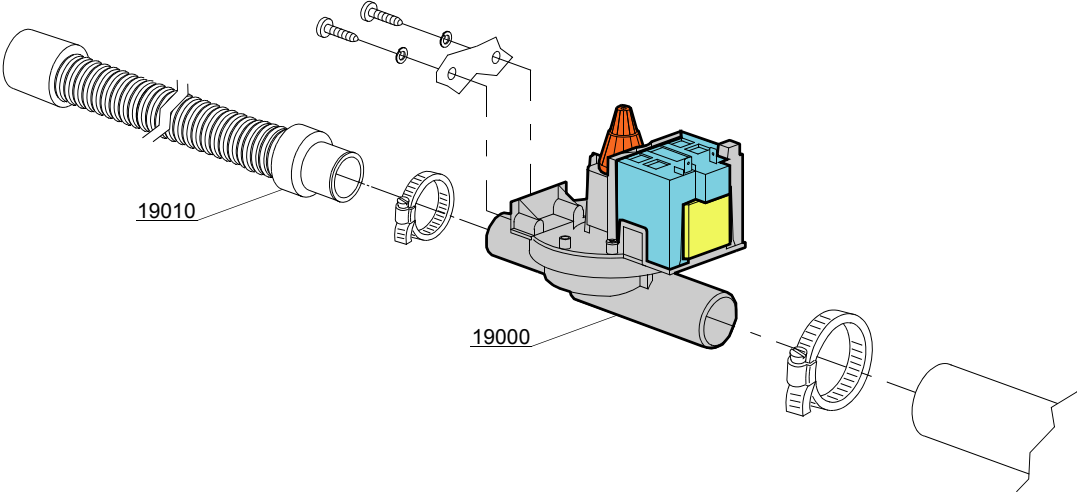

Spare parts

ID	P-code	SN from	SN to	Mod.	Acces.	Volt	Description
Module: Drain pump group							
19000	15101/A		-	i,em,e	dp	A	Drain pump - 50Hz
19010	10727		-	i,em,e	dp		Drain pipe

em=ELECTROMECHANICAL SWITCHES, e=ELECTRONICAL SWITCHES, lw=LOWER WASHING, uw=LOWER AND UPPER WASHING, i=INSULATED MODEL

LUX40EL=LUX40EL

bt=BREAK TANK, bp=BOOSTER PUMP, dvgw=DVGW, cr=COLD RINSE, ws=WATER SOFTNER, dd=DETERGENT DISPENSER, dp=DRAIN PUMP

A=3/N/PE~380-400V 50-60Hz, D=3/PE~200-210V 50-60Hz, F=2/PE~220-240V 50-60Hz, G=3/N/PE~415V 50-60Hz, H=3/PE~220-230V 50-60Hz, K=3/PE~380-400V 50-60Hz, L=3/PE~415V 50-60Hz, M=3/PE~440V 60Hz, P=1/N/PE~220-230V 50-60Hz, R=2/PE~220-240V 50-60Hz, U=1/N/PE~240V 50-60Hz, V=3/PE~240V 50-60Hz, W=1/N/PE~100-110V 50-60Hz

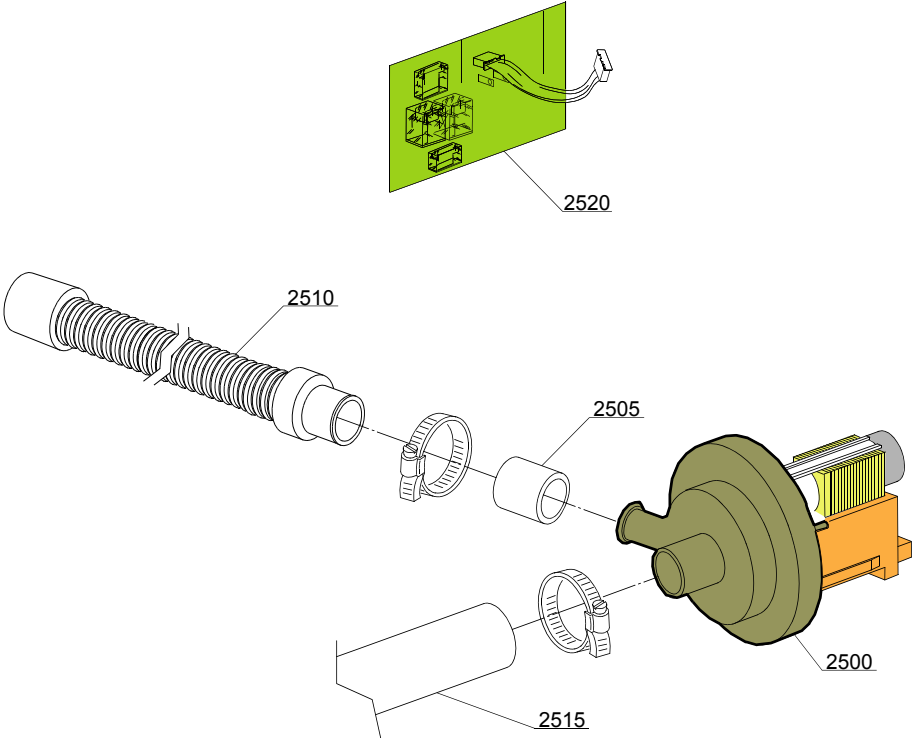

15_004_e

Spare parts

ID	P-code	SN from	SN to	Mod.	Acces.	Volt	Description
Module: Drain pump group							
2500	15101		-	i,em,e	dp		Drain pump 220/240V 50Hz
2505	15101/D		-	i,em,e	dp		Pipe fitting (minimum 3 pieces)
2510	10727		-	i,em,e	dp		Drain pipe
2515	18044		-	i,em,e	dp		Ø28 top wash pipe
2520	50554		-	i,em,e	dp		Electronic timer for Exp - Ps card
2525	11806		-	i,em,e	dp		25/40 clamp (minimum 2 pieces)

em=ELECTROMECHANICAL SWITCHES, e=ELECTRONICAL SWITCHES, lw=LOWER WASHING, uw=LOWER AND UPPER WASHING, i=INSULATED MODEL

LUX40EL=LUX40EL

bt=BREAK TANK, bp=BOOSTER PUMP, dvgw=DVGW, cr=COLD RINSE, ws=WATER SOFTNER, dd=DETERGENT DISPENSER, dp=DRAIN PUMP

A=3/N/PE~380-400V 50-60Hz, D=3/PE~200-210V 50-60Hz, F=2/PE~220-240V 50-60Hz, G=3/N/PE~415V 50-60Hz, H=3/PE~220-230V 50-60Hz, K=3/PE~380-400V 50-60Hz, L=3/PE~415V 50-60Hz, M=3/PE~440V 60Hz, P=1/N/PE~220-230V 50-60Hz, R=2/PE~220-240V 50-60Hz, U=1/N/PE~240V 50-60Hz, V=3/PE~240V 50-60Hz, W=1/N/PE~100-110V 50-60Hz

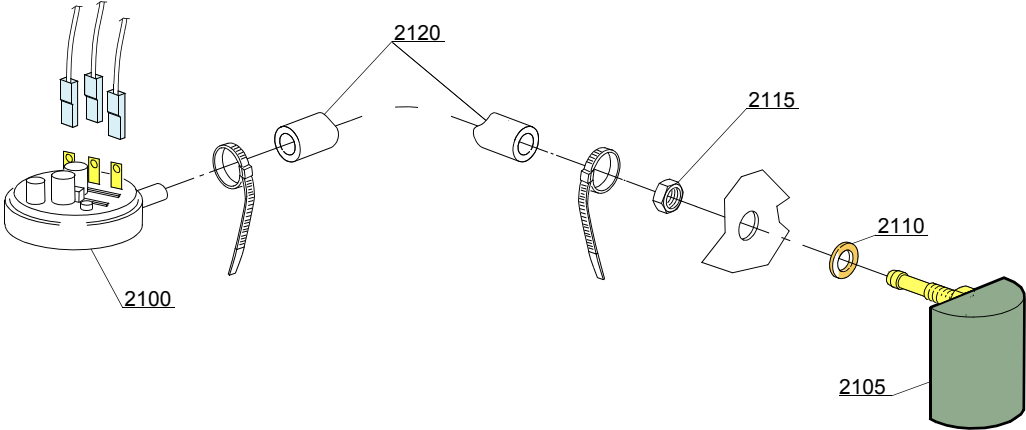

16_001_e

Spare parts

ID	P-code	SN from	SN to	Mod.	Acces.	Volt	Description
Module:Pressure switch group with air trap							
2100	540450		-	i,em,e			"EL" 59-25 pressure switch
2105	135911/B		-	em,i,e			Grey air trap assembly
2110	13301		-	i,em,e			O-ring (minimum 10 pieces) - D14x8x1,5
2115	11702		-	i,em,e			M8 stainless steel nut (minimum 10 pieces)
2120	14508		-	i,em,e			4,5X9 EPDM rubber hose (minimum 2mt)

em=ELECTROMECHANICAL SWITCHES, e=ELECTRONICAL SWITCHES, lw=LOWER WASHING, uw=LOWER AND UPPER WASHING, i=INSULATED MODEL

LUX40EL=LUX40EL

bt=BREAK TANK, bp=BOOSTER PUMP, dvgw=DVGW, cr=COLD RINSE, ws=WATER SOFTNER, dd=DETERGENT DISPENSER, dp=DRAIN PUMP

A=3/N/PE~380-400V 50-60Hz, D=3/PE~200-210V 50-60Hz, F=2/PE~220-240V 50-60Hz, G=3/N/PE~415V 50-60Hz, H=3/PE~220-230V 50-60Hz, K=3/PE~380-400V 50-60Hz, L=3/PE~415V 50-60Hz, M=3/PE~440V 60Hz, P=1/N/PE~220-230V 50-60Hz, R=2/PE~220-240V 50-60Hz, U=1/N/PE~240V 50-60Hz, V=3/PE~240V 50-60Hz, W=1/N/PE~100-110V 50-60Hz

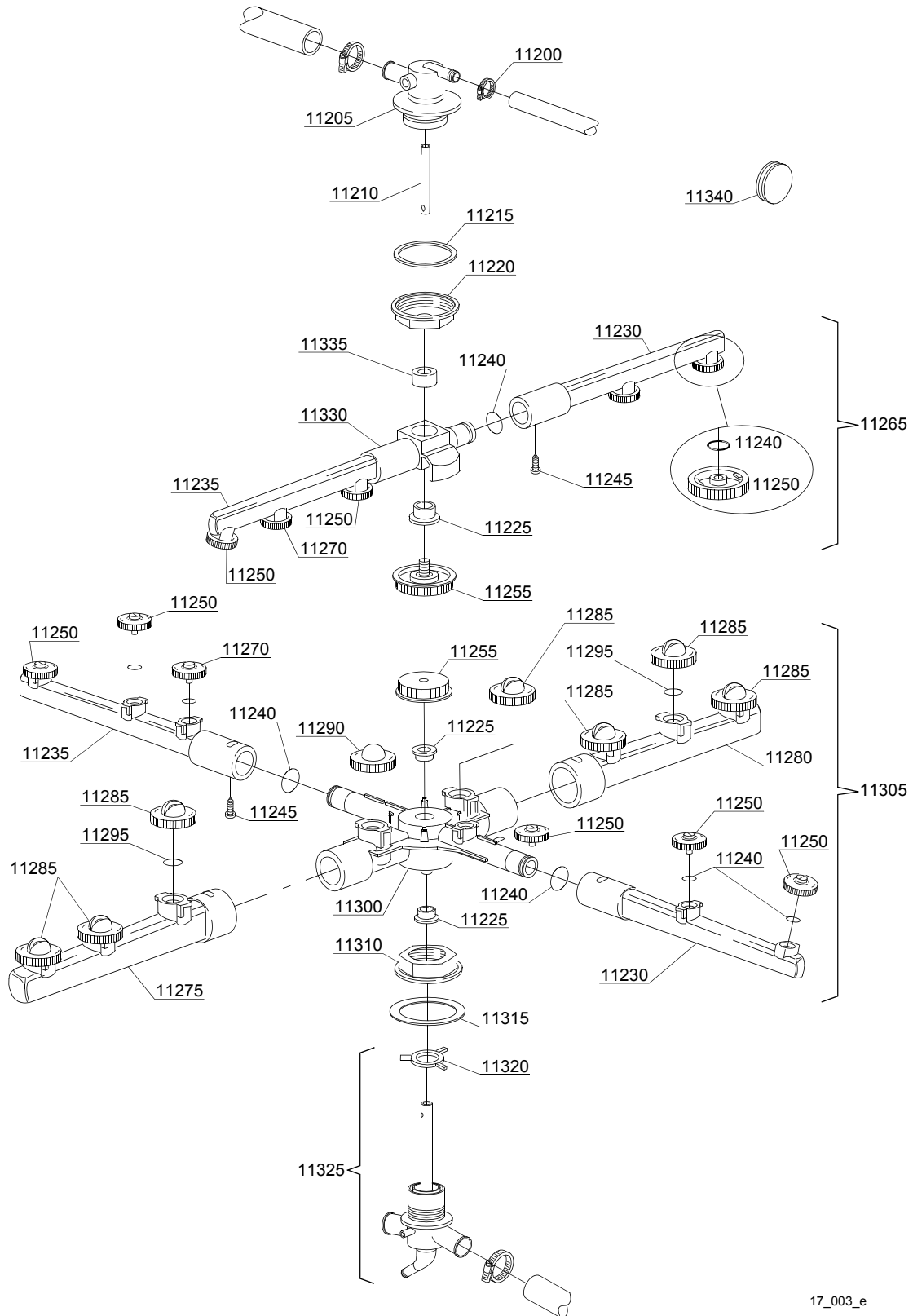

17_003_e

Spare parts

ID	P-code	SN from	SN to	Mod.	Acces.	Volt	Description
Module:Turret group with rotating arms							
11200	11807		-	lw			12/22 clamp (minimum 3 pieces)
11205	540071		-	lw			Top turret for rinse rotor
11210	540014		-	lw			Top rinse axle
11215	540032		-	lw			Ø57x43x1,5 plane O-ring (minimum 2 pieces)
11220	540070		-	lw			Ø10 hole closed nut
11225	13319		-	lw			Sliding washer (minimum 2 pieces)
11230	10374		-	lw			Right rinse pipe
11235	10375		-	lw			Left rinse pipe
11240	13002		-	lw			OR R6 NBR O-ring (minimum 10 pieces)
11245	11004		-	lw			4x10 TCB Ø8 spax toothed screw
11250	10371		-	lw			Opened head rinse nozzle (minimum 5 pieces)
11255	10377		-	lw			Handle with insert
11265	10997		-	lw			Top rinse group
11270	10372		-	lw			Closed head rinse nozzle (minimum 2 pieces)
11275	10367		-	lw			Right wash pipe
11280	10368		-	lw			Left wash pipe
11285	10369		-	lw			Opened head wash nozzle (minimum 2 pieces)
11290	10370		-	lw			Closed head wash nozzle (minimum 2 pieces)
11295	13009		-	lw			OR 2050 NBR O-ring (minimum 40 pieces)
11300	10376		-	lw			Wash rotor
11300	540043		-	lw			Wash rotor
11305	540999		-	lw			Lower wash/rinse group
11310	540093		-	lw			Turret fixing nut
11315	540034		-	lw			Ø57x43x4 turret plane O-ring
11320	10225		-	lw			Guide pipe
11325	540068		-	lw			Lower turret assembly for rotor
11330	10359		-	lw			Rinse rotor
11335	13320		-	lw			Sliding washer (minimum 3 pieces)

em=ELECTROMECHANICAL SWITCHES, e=ELECTRONICAL SWITCHES, lw=LOWER WASHING, uw=LOWER AND UPPER WASHING, i=INSULATED MODEL

LUX40EL=LUX40EL

bt=BREAK TANK, bp=BOOSTER PUMP, dvgw=DVGW, cr=COLD RINSE, ws=WATER SOFTNER, dd=DETERGENT DISPENSER, dp=DRAIN PUMP

A=3/N/PE~380-400V 50-60Hz, D=3/PE~200-210V 50-60Hz, F=2/PE~220-240V 50-60Hz, G=3/N/PE~415V 50-60Hz, H=3/PE~220-230V 50-60Hz, K=3/PE~380-400V 50-60Hz, L=3/PE~415V 50-60Hz, M=3/PE~440V 60Hz, P=1/N/PE~220-230V 50-60Hz, R=2/PE~220-240V 50-60Hz, U=1/N/PE~240V 50-60Hz, V=3/PE~240V 50-60Hz, W=1/N/PE~100-110V 50-60Hz

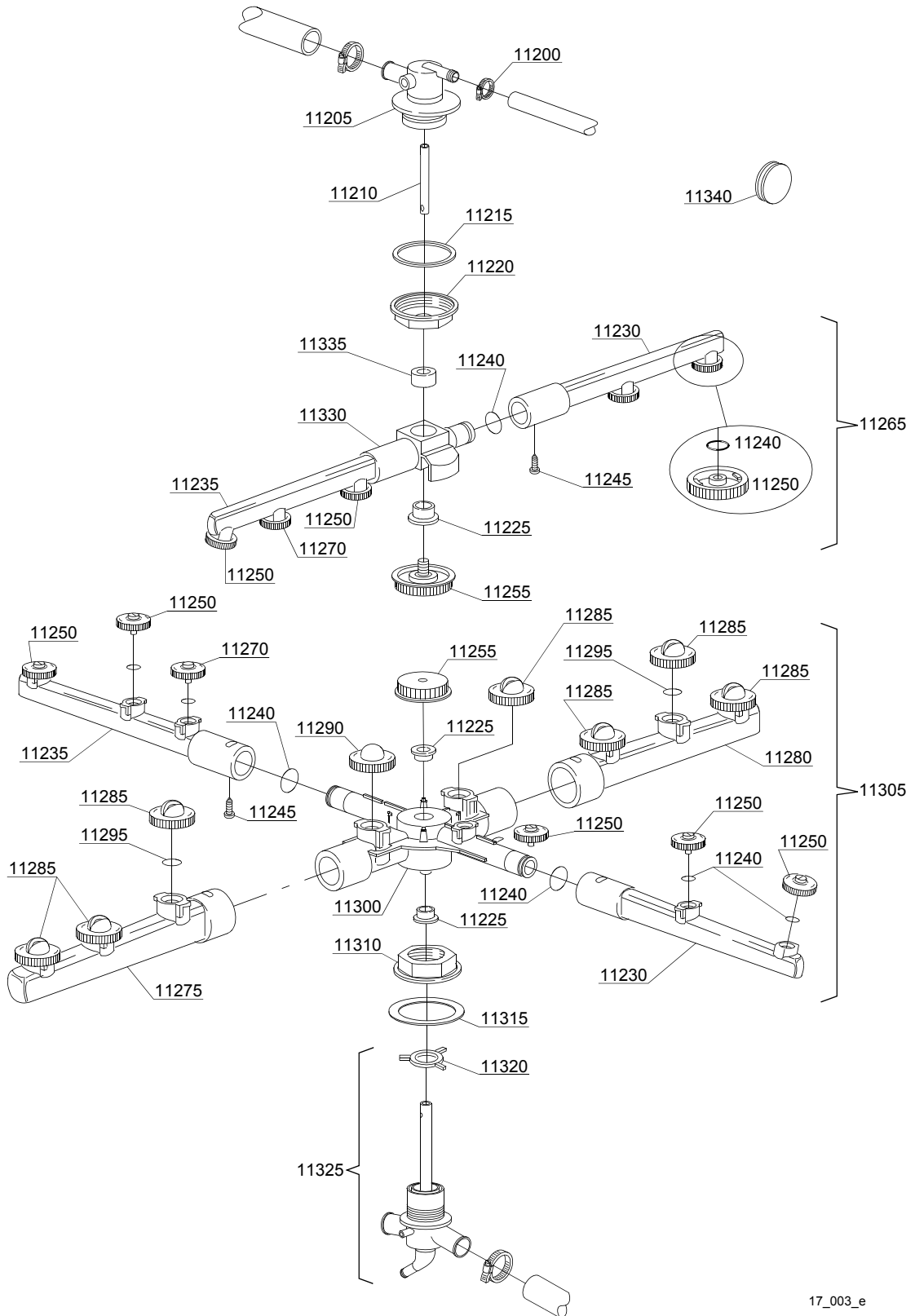

17_003_e

Spare parts

ID	P-code	SN from	SN to	Mod.	Acces.	Volt	Description
Module:Turret group with rotating arms							
11340	13316/A		-	lw			DVGW hole O-ring

em=ELECTROMECHANICAL SWITCHES, e=ELECTRONICAL SWITCHES, lw=LOWER WASHING, uw=LOWER AND UPPER WASHING, i=INSULATED MODEL

LUX40EL=LUX40EL

bt=BREAK TANK, bp=BOOSTER PUMP, dvgw=DVGW, cr=COLD RINSE, ws=WATER SOFTNER, dd=DETERGENT DISPENSER, dp=DRAIN PUMP

A=3/N/PE~380-400V 50-60Hz, D=3/PE~200-210V 50-60Hz, F=2/PE~220-240V 50-60Hz, G=3/N/PE~415V 50-60Hz, H=3/PE~220-230V 50-60Hz, K=3/PE~380-400V 50-60Hz, L=3/PE~415V 50-60Hz, M=3/PE~440V 60Hz, P=1/N/PE~220-230V 50-60Hz, R=2/PE~220-240V 50-60Hz, U=1/N/PE~240V 50-60Hz, V=3/PE~240V 50-60Hz, W=1/N/PE~100-110V 50-60Hz

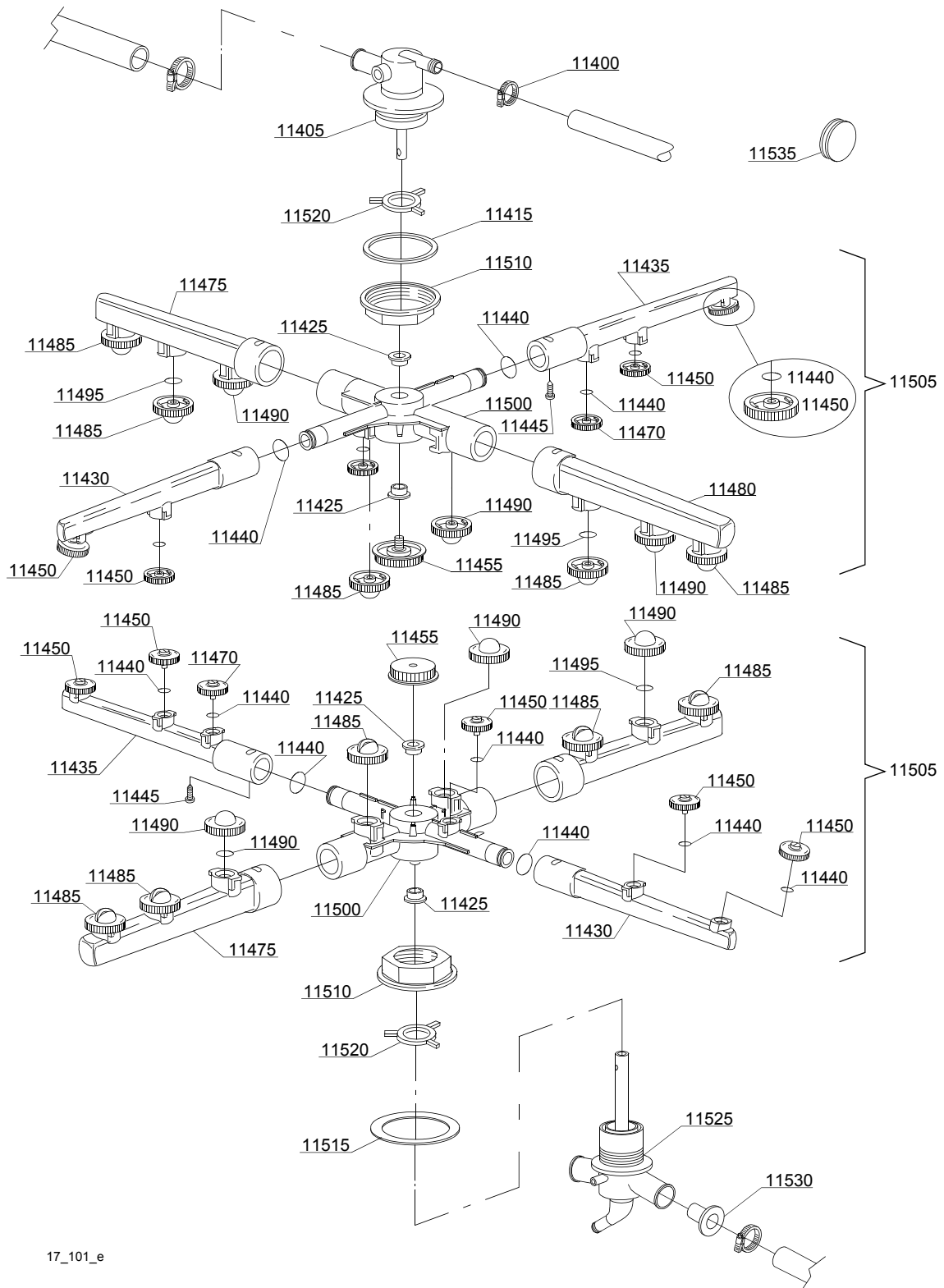

17_101_e

Spare parts

ID	P-code	SN from	SN to	Mod.	Acces.	Volt	Description
Module:Turret group with rotating arms							
11400	11807		-	uw			12/22 clamp (minimum 3 pieces)
11405	540071		-	uw			Top turret grey assembly for rotor
11415	540032		-	uw			Ø57x43x1,5 plane O-ring (minimum 2 pieces)
11425	13319		-	uw			Sliding washer (minimum 2 pieces)
11430	10374		-	uw			Right rinse pipe
11435	10375		-	uw			Left rinse pipe
11440	13002		-	uw			OR R6 NBR O-ring (minimum 10 pieces)
11445	11004		-	uw			4x10 TCB Ø8 spax toothed screw
11450	10371		-	uw			Opened head rinse nozzle (minimum 2 pieces)
11455	10377		-	uw			Handle with insert
11470	10372		-	uw			Closed head rinse nozzle (minimum 5 pieces)
11475	10367		-	uw			Right wash pipe
11480	10368		-	uw			Left wash pipe
11485	10378		-	uw			1,9 opened head wash nozzle (minimum 2 pieces)
11490	10370		-	uw			Closed head wash nozzle (minimum 2 pieces)
11495	13009		-	uw			OR 2050 NBR O-ring (minimum 40 pieces)
11500	540043		-	uw			Wash rotor
11505	540996		-	uw			Top/lower wash/rinse group
11510	540093		-	uw			Turret fixing nut
11515	540034		-	uw			Ø57x43x4 turret plane O-ring
11520	10225		-	uw			Guide pipe
11525	540068		-	uw			Lower turret grey assembly for rotor
11530	18249		-	uw			Flux reducer
11535	13316/A		-	lw			DVGW hole O-ring

em=ELECTROMECHANICAL SWITCHES, e=ELECTRONICAL SWITCHES, lw=LOWER WASHING, uw=LOWER AND UPPER WASHING, i=INSULATED MODEL

LUX40EL=LUX40EL

bt=BREAK TANK, bp=BOOSTER PUMP, dvgw=DVGW, cr=COLD RINSE, ws=WATER SOFTNER, dd=DETERGENT DISPENSER, dp=DRAIN PUMP

A=3/N/PE~380-400V 50-60Hz, D=3/PE~200-210V 50-60Hz, F=2/PE~220-240V 50-60Hz, G=3/N/PE~415V 50-60Hz, H=3/PE~220-230V 50-60Hz, K=3/PE~380-400V 50-60Hz, L=3/PE~415V 50-60Hz, M=3/PE~440V 60Hz, P=1/N/PE~220-230V 50-60Hz, R=2/PE~220-240V 50-60Hz, U=1/N/PE~240V 50-60Hz, V=3/PE~240V 50-60Hz, W=1/N/PE~100-110V 50-60Hz

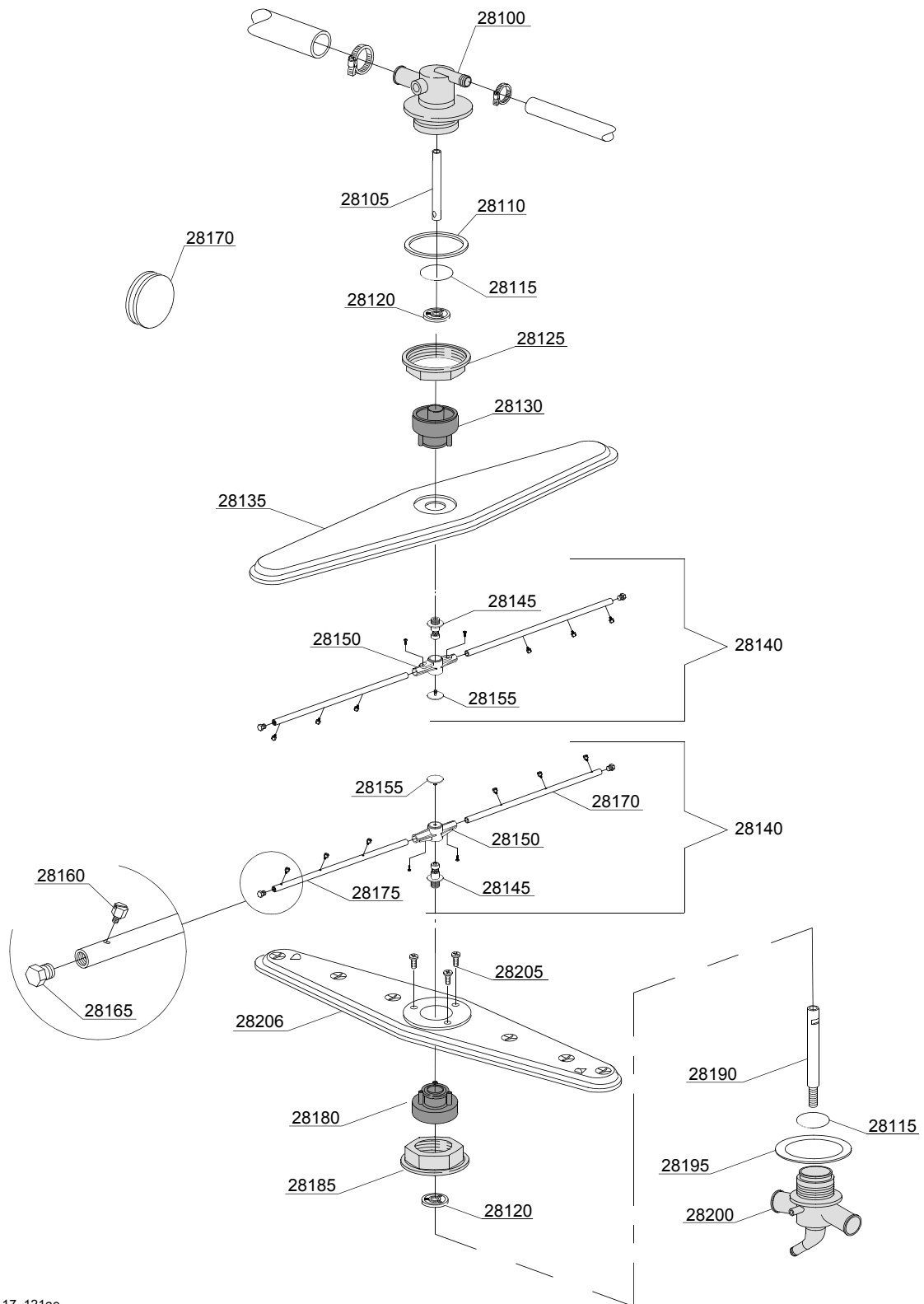

17_121ae

Spare parts

ID	P-code	SN from	SN to	Mod.	Acces.	Volt	Description
Module:Turret group with rotating arms							
28100	540075		-	uw,em			Top turret
28105	540081		-	uw			Top axle extension
28110	540032		-	uw			Plain O-ring (minimum 2 pieces)
28115	540079		-	uw			Seal ring for hub
28120	540076		-	uw			Guide pipe
28125	540093		-	uw			Nut for top turret fixing
28130	540078		-	uw			Top hub for rotor
28135	540085		-	uw			Top wash rotor
28140	540083		-	uw			Rinse group
28145	10651		-	uw			Rinse axle
28150	10650		-	uw			Rinse arm
28155	10652		-	uw			Rinse arm screw
28160	560018		-	uw			Stainless steel rinse nozzle
28165	560017		-	uw			Rinse arm plug
28170	10653		-	uw			Right rinse arm - stainless steel nozzle
28175	10654		-	uw			Left rinse arm - stainless steel nozzle
28180	540077		-	uw			Lower hub for rotor
28185	540093		-	uw			Nut for lower turret fixing
28190	540082		-	uw			Lower axle extension
28195	540034		-	uw			Plain O-ring
28200	540074		-	uw			Lower turret
28205	11006		-	uw			2,9x13 TS Stainless steel screw (minimum 20 pieces)
28206	540084		-	uw			Inferior wash rotor

em=ELECTROMECHANICAL SWITCHES, e=ELECTRONICAL SWITCHES, lw=LOWER WASHING, uw=LOWER AND UPPER WASHING, i=INSULATED MODEL

LUX40EL=LUX40EL

bt=BREAK TANK, bp=BOOSTER PUMP, dvgw=DVGW, cr=COLD RINSE, ws=WATER SOFTNER, dd=DETERGENT DISPENSER, dp=DRAIN PUMP

A=3/N/PE~380-400V 50-60Hz, D=3/PE~200-210V 50-60Hz, F=2/PE~220-240V 50-60Hz, G=3/N/PE~415V 50-60Hz, H=3/PE~220-230V 50-60Hz, K=3/PE~380-400V 50-60Hz, L=3/PE~415V 50-60Hz, M=3/PE~440V 60Hz, P=1/N/PE~220-230V 50-60Hz, R=2/PE~220-240V 50-60Hz, U=1/N/PE~240V 50-60Hz, V=3/PE~240V 50-60Hz, W=1/N/PE~100-110V 50-60Hz

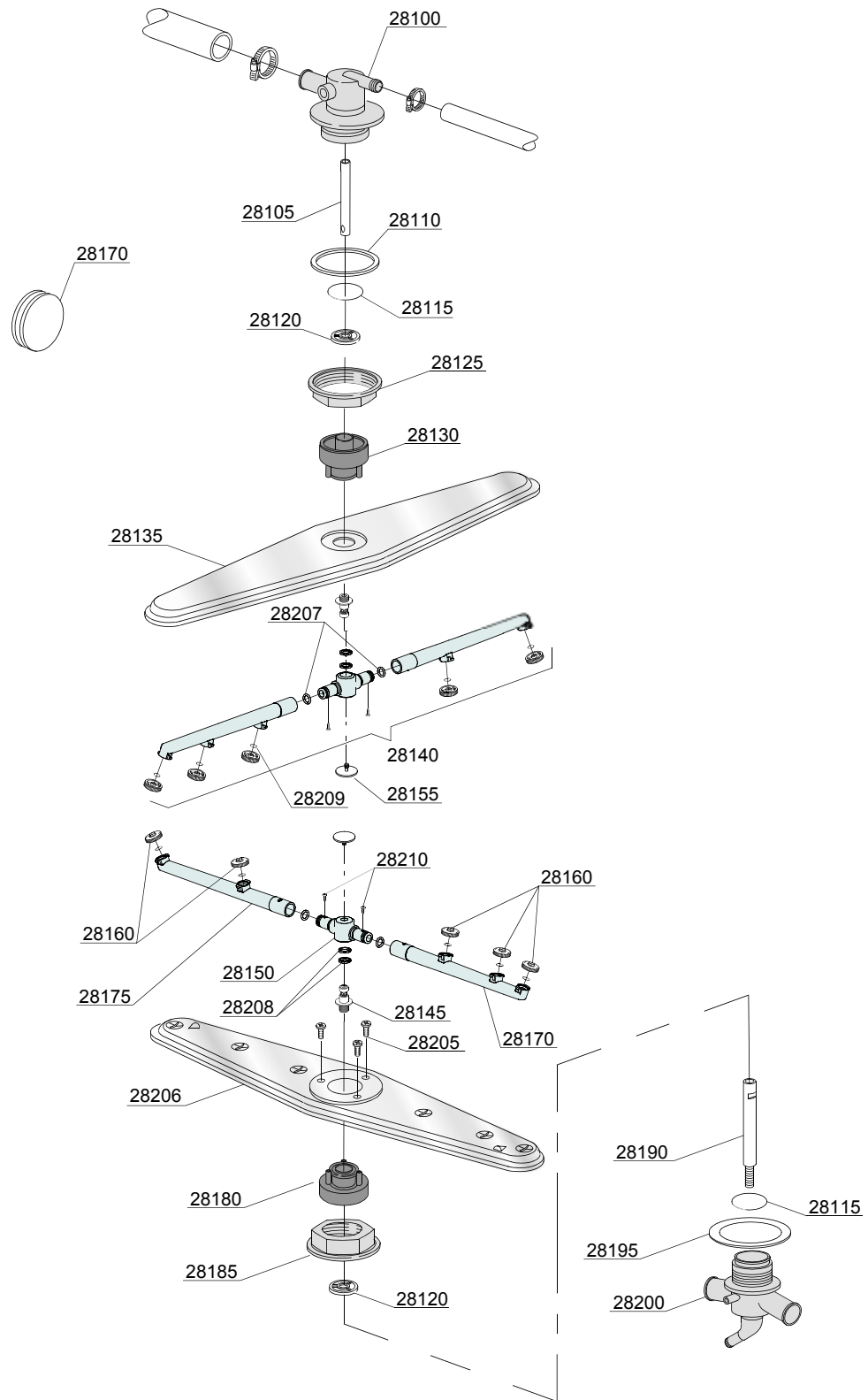

17_121be

Spare parts

ID	P-code	SN from	SN to	Mod.	Acces.	Volt	Description
Module:Turret group with rotating arms							
28100	540075		-	uw,em			Top turret
28105	540081		-	uw			Top axle extension
28110	540032		-	uw			Plain O-ring (minimum 2 pieces)
28115	540079		-	uw			Seal ring for hub
28120	540076		-	uw			Guide pipe
28125	540093		-	uw			Nut for top turret fixing
28130	540078		-	uw			Top hub for rotor
28135	540085		-	uw			Top wash rotor
28140	540089		-	uw			Rinse group
28145	10651		-	uw			Rinse axle
28150	75920/A		-	uw			Rinse arm
28155	10652		-	uw			Rinse arm screw
28160	10371		-	uw			Rinse nozzle
28165	560017		-	uw			Rinse arm plug
28170	540089/S		-	uw			Left rinse arm
28175	540089/D		-	uw			Right rinse arm
28180	540077		-	uw			Lower hub for rotor
28185	540093		-	uw			Nut for lower turret fixing
28190	540082		-	uw			Lower axle extension
28195	540034		-	uw			Plain O-ring
28200	540074		-	uw			Lower turret
28205	11006		-	uw			2,9x13 TS Stainless steel screw (minimum 20 pieces)
28206	540084		-	uw			Inferior wash rotor
28207	13002		-	uw			OR R6 NBR O-ring (minimum 10 pieces)
28208	75920/B		-	uw			Rinse arm
28209	13002		-	uw			OR R6 NBR O-ring (minimum 10 pieces)
28210	11004		-	uw			4x10 TCB Ø8 spax toothed screw

em=ELECTROMECHANICAL SWITCHES, e=ELECTRONICAL SWITCHES, lw=LOWER WASHING, uw=LOWER AND UPPER WASHING, i=INSULATED MODEL

LUX40EL=LUX40EL

bt=BREAK TANK, bp=BOOSTER PUMP, dvgw=DVGW, cr=COLD RINSE, ws=WATER SOFTNER, dd=DETERGENT DISPENSER, dp=DRAIN PUMP

A=3/N/PE~380-400V 50-60Hz, D=3/PE~200-210V 50-60Hz, F=2/PE~220-240V 50-60Hz, G=3/N/PE~415V 50-60Hz, H=3/PE~220-230V 50-60Hz, K=3/PE~380-400V 50-60Hz, L=3/PE~415V 50-60Hz, M=3/PE~440V 60Hz, P=1/N/PE~220-230V 50-60Hz, R=2/PE~220-240V 50-60Hz, U=1/N/PE~240V 50-60Hz, V=3/PE~240V 50-60Hz, W=1/N/PE~100-110V 50-60Hz