



AENOR
Organismo Notificado
0099

Applus®
LGA1
Organismo Notificado
0370



TOLERANCIAS GENERALES: ±0.5 mm

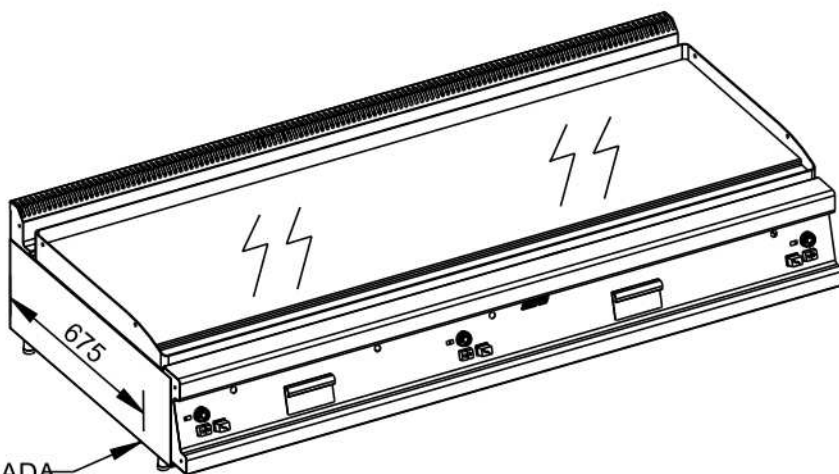
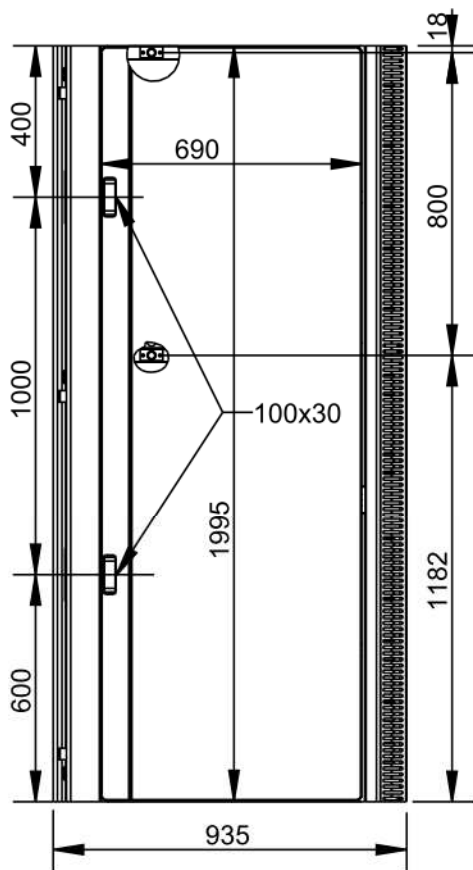
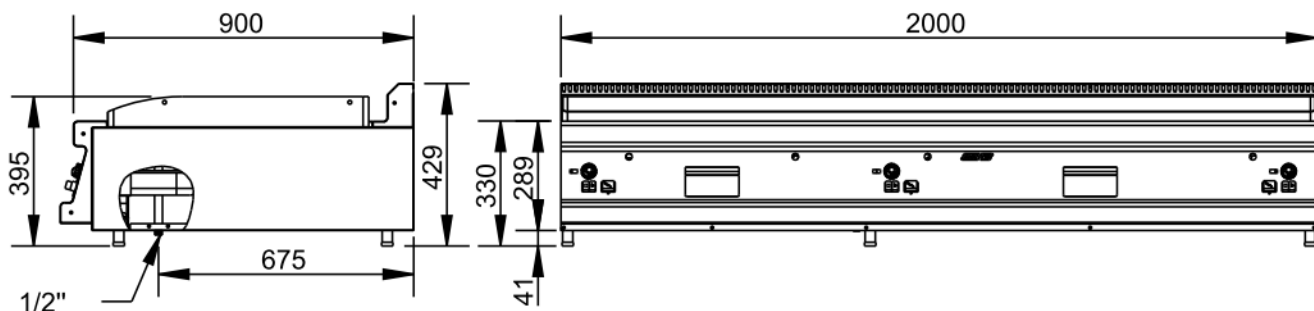

ENTRADA GAS

POTENCIA TOTAL: 40,25 KW
 3 ZONAS INDEPENDIENTES, 2 DE 17,25 KW Y 1 DE 5,75KW
 2 ENTRADAS GAS 1/2", 1 DE 17,25 KW Y 1 DE 22,5 KW
 2-CAJONES PARA RECOGIDA DE GRASA DE 325X135X60



FAMILIA: COCINAS 2008

FECHA: 19/01/11

MODELO: 3684S

PESO(Kg): 264.758

DENOMINACION:
FRYTOP GAS CROMO DURO 2000X900

ESCALA:
1/20

MATERIAL:
INOX

CODIGO:
3684S



Applus®
LGA1
Organismo
Notificado
0370

AENOR
Organismo
Notificado
0099



TOLERANCIAS GENERALES: ±0.5 mm

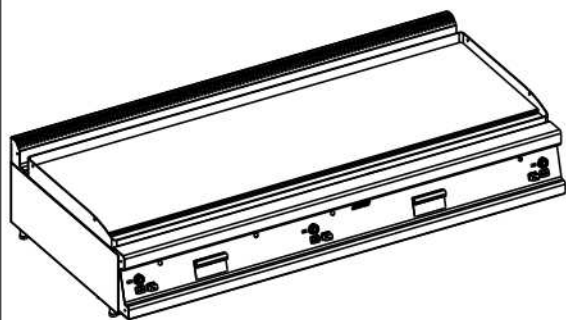

QT	COD	DESCRIPCION
3	2193	CABLE PIEZO L=370
3	3747	PIEZO ELECTRICO SIT
6	6038	PATA REGULABLE AP.SNACK
1	330513	TRASERO HORNILLO 1200
1	330613	TRASERO HORNILLO 800
1	340102	SEPARADOR FUEGOS 900
1	340178	TAPETA DERECHA PETO 750/900
1	340179	TAPETA IZQ. PETO 750/900
1	350565	FRONTAL INFERIOR 800
1	350665	FRONTAL INFERIOR 1200
3	362133	PROTECTOR PIEZO ELECTRICO
3	362476	SOPORTE VALV.MINISIT-CONTACTOR
2	368333	RAMPA CAÍDA ACEITE XXL
1	300185PC	BATERIA COMPLETA 1 VALVULA 400
1	300585PC	BATERIA COMPLETA 2 VALVULAS 1200
3	3103M	VALVULA SIT COMPLETA
2	340208M	CONJ. LAT.SUPERIOR 900 DCH
2	340209M	CONJ. LAT.SUPERIOR 900 IZQ
1	361116M	DEFLECTOR MONTADO 400X900
2	362149C	CONJUNTO CUBETA / CAJON FT
2	368316M	DEFLECTOR MONTADO 1200X900
1	368406P	PLANCHA CR LISA 1995X690
1	368439C	CONJUNTO FRONTAL FT 2000
1	506122C	CONJUNTO PETO 2000
3	C5820049	TERMOPAR LISO M9X1 L 320
3	T06030	TUBO AL D.6 L.300
1	T10030	TUBO AL D.10 L.300
2	T10075	TUBO AL D.10 L.750

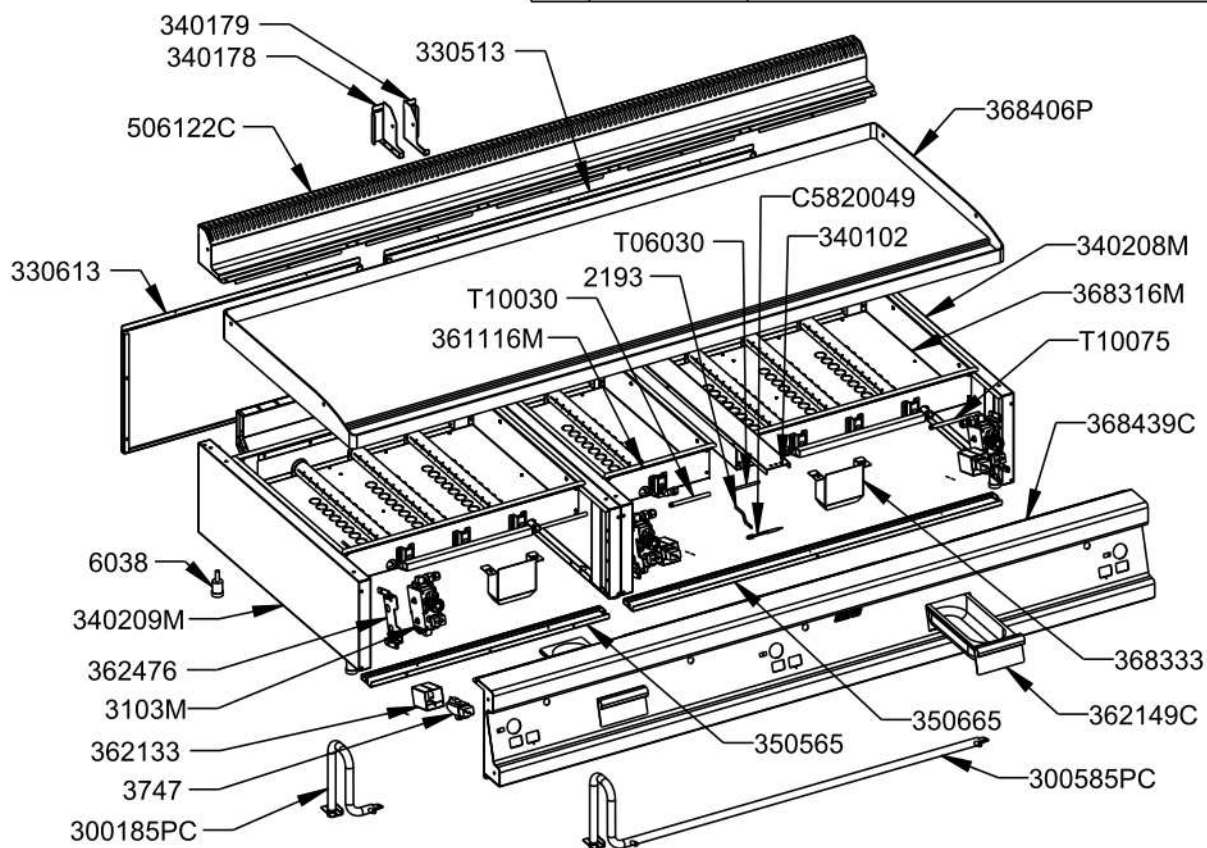

FAMILIA: COCINAS 2008

FECHA: 19/01/11

MODELO: 3684S

PESO(Kg): 264.758

DENOMINACION:
FRYTOP GAS CROMO DURO 2000X900

ESCALA:
1/20

MATERIAL:
INOX

CODIGO:
3684S



Applus®
LGA1
Organismo
Notificado
0370

AENOR
Organismo
Notificado
0099



TOLERANCIAS GENERALES: ± 0.5 mm

QT	COD	DESCRIPCION	FAB.	MATERIAL	DATA	PESO
7	300184	AIREADOR QUEMADOR	SÍ	INOFER 0.8	09/06/09	0.023
4	300388	CORRELLAMAS	SÍ	INOFER 0.8	05/02/09	0.106
2	300399	TAPA 20X20 C/AGUJERO D.12	SÍ	FE 1.2	02/09/08	0.003
2	301399	TAPA 20X20	SÍ	FE 1.2	02/09/08	0.004
2	330294	PLETINA BASE BATERÍA	SÍ	FE 1.5	03/11/08	0.021
1	330513	TRASERO HORNILLO 1200	SÍ	INOFER 0.8	11/12/08	2.916
1	330613	TRASERO HORNILLO 800	SÍ	INOFER 0.8	11/12/08	1.923
6	330675	REFUERZO PATA	SÍ	GALVA 1.5	11/12/08	0.429
1	340102	SEPARADOR FUEGOS 900	SÍ	INOX 1.2	00/00/00	0.643
2	340178	TAPETA DERECHA PETO 750/900	SÍ	INOFER 1.2	30/11/07	0.135
2	340179	TAPETA IZQ. PETO 750/900	SÍ	INOFER 1.2	30/11/07	0.135
2	340208	LATERAL SUPERIOR 900 DCHO	SÍ	INOFER 0.8	10/03/09	2.168
2	340209	LATERAL SUPERIOR 900 IZQ.	SÍ	INOFER 0.8	10/03/09	2.168
1	350178	TAPETA LATERAL DERECHA FRONTAL	SÍ	INOFER 1.2	26/06/07	0.109
1	350179	TAPETA LATERAL IZQUIEDA FRONTAL	SÍ	INOFER 1.2	26/06/07	0.109
1	350565	FRONTAL INFERIOR 800	SÍ	INOFER 0.8	15/06/10	0.394
1	350665	FRONTAL INFERIOR 1200	SÍ	INOFER 0.8	28/09/10	0.609
1	361116	DEFLECTOR FRYTOP 400X900	SÍ	INOFER 0.8	06/05/09	2.151
1	361126	BURLETE CERAM.400x900-C6580179	SÍ	FIBRA	06/05/09	0.102
2	361416	DEFLECTOR FRYTOP 800X900	SÍ	INOFER 0.8	17/01/11	3.744
2	361426	BURLETE CERAM.800X900-C6580179	SÍ	FIBRA	12/03/09	0.294
3	362133	PROTECTOR PIEZO ELECTRICO	SÍ	GALVA 0.6	25/09/08	0.077
2	362148	GUIA CAJON FT(GN 2/8-65)	SÍ	INOFER 0.8	24/10/08	0.280
2	362149	TIRADOR CAJON FT (GN2/8-65)	SÍ	INOX 1.2	19/11/07	0.162
1	362152	SALIDA VAHOS FT400	SÍ	GALVA 0.8	06/05/09	0.785
2	362452	SALIDA VAHOS FT800	SÍ	GALVA 0.8	01/04/09	1.721
3	362476	SOPORTE VALV.MINISIT-CONTACTOR	SÍ	GALVA 1.5	24/09/08	0.122
6	362478	TAPETA LATERAL DEFLECTOR	SÍ	GALVA 0.8	01/04/09	0.046
2	368333	RAMPA CAÍDA ACEITE XXL	SÍ	INOFER 0.8	03/11/10	0.163
1	368439	FRONTAL MANDOS FRYTOP 2000	SÍ	INOX 1.2	11/11/10	10.028
3	490133	PROTECTOR BULBO	SÍ	INOFER 0.8	28/09/10	0.060
1	506122	PETO SOBRE 2000	SÍ	INOX 1.2	23/06/10	3.993
2	3306751	REFUERZO PATA C/ENCAJE BATERIA	SÍ	GALVA 1.5	09/01/09	0.361
2	3621491	SOPORTE TIRADOR CAJON FT	SÍ	INOFER 1.2	27/06/08	0.058
2	340208M	CONJ. LAT.SUPERIOR 900 DCH	SÍ	INOX	17/01/11	3.042
2	340209M	CONJ. LAT.SUPERIOR 900 IZQ	SÍ	INOX	17/01/11	2.973
1	361116M	DEFLECTOR MONTADO 400X900	SÍ	INOX	28/01/11	3.958
2	362149C	CONJUNTO CUBETA / CAJON FT	SÍ	INOX	27/06/08	0.775
2	368316M	DEFLECTOR MONTADO 1200X900	SÍ	INOX	17/01/11	8.296
1	368439C	CONJUNTO FRONTAL FT 2000	SÍ	INOX	11/11/10	10.881
1	506122C	CONJUNTO PETO 2000	SÍ	INOX	23/06/10	4.288
2	TESTA140	ANGULO TESTATINA 140	SÍ	INOX 0.6	29/08/07	0.016
8	TESTA35	ANGULO TESTATINA 35	SÍ	INOX 0.6	29/08/07	0.004
4	TESTA70	ANGULO TESTATINA 70	SÍ	INOX 0.6	29/08/07	0.008
8	1014	REMACHE ROSCADO M-10	NO	ZN	17/12/09	0.008
24	1051	TORNILLO ZN M4X15 DIN 84	NO	FE ZN	01/01/09	0.003
4	2193	CABLE PIEZO L=370	NO	FIBRA/CU	01/01/09	0.003
3	3103	VALVULA MINI SIT	NO	AL	01/01/09	0.700



FAMILIA: COCINAS 2008

FECHA: 19/01/11

MODELO: 3684S

PESO(Kg): 264.758

DENOMINACION:
FRYTOP GAS CROMO DURO 2000X900

ESCALA:
1/20

MATERIAL:
INOX

CODIGO:
3684S



Applus®
LGA1
Organismo
Notificado
0370

AENOR
Organismo
Notificado
0099



TOLERANCIAS GENERALES: ±0.5 mm

3	3747	PIEZO ELECTRICO SIT	NO	PLAST	05/09/08	0.076
3	3765	MANDO VALV. SIT	NO	PLASTICO	01/01/09	0.014
8	3781	TUERCA M16X1.5 D.10	NO	LATON	05/09/08	0.015
8	3782	BICONO D.10 LATON	NO	LATON	01/01/09	0.001
6	3785	JUNTA VALVULA MINISIT	NO	GOMA	01/01/09	0.000
6	6038	PATA REGULABLE AP.SNACK	NO	BAQUELITA	01/12/93	0.068
2	330189	MANGUITO M16X1.5 TUBO D.10	NO	FE	22/09/08	0.007
1	300185P	BATERÍA 1 VALVULA 400	NO	FE 1/2"	13/01/09	0.419
1	300185PC	BATERIA COMPLETA 1 VALVULA 400	NO	FE ZINCADO	13/01/09	0.445
1	300585P	BATERÍA 2 VALVULAS 1200	NO	FE 1/2"	13/01/09	1.170
1	300585PC	BATERIA COMPLETA 2 VALVULAS 1200	NO	FE ZINCADO	13/01/09	1.202
3	3103M	VALVULA SIT COMPLETA	NO	AL	05/09/08	0.940
7	361187P	QUEMADOR TUBULAR D.40 L.550	NO	INOX	05/08/09	0.566
3	362189P	TUBO COBRE 10X8 L.25	NO	CU 10X8	13/01/09	0.006
6	362489P	MACHON D.10 - 3/8" - M16X1.5	NO	LATON	01/10/08	0.029
2	362886P	COLECTOR 3 SALIDAS	NO	FE	22/01/09	0.225
2	362886PC	COLECTOR 3 SALIDAS	NO	FE ZINCADO	22/01/09	0.239
1	368406P	PLANCHA CR LISA 1995X690	NO	CR 20mm	11/11/10	202.548
3	A1018996	RACORD BUJIA	NO	LATON	01/01/09	0.004
3	A1018997	RACORD PILOTO	NO	LATON	01/01/09	0.004
3	A1018998	RACORD TERMOPAR	NO	LATON	01/01/09	0.004
3	A1018999	BICONO PILOTO	NO	LATON	01/01/09	0.002
3	C5810129	PILOTO POLIDORO	NO	FE	01/01/09	0.053
3	C5810129M	PILOTO POLIDORO COMPLETO	NO	FE	04/01/11	0.074
3	C5810139	BUJIA	NO	CER	01/01/09	0.004
3	C5810159	INY.PILOTO GN (27.2) 2 AGUJ.	NO	LATON	01/01/09	0.002
3	C5810169	INY.PILOTO GLP (22) 1 AGUJ.	NO	LATON	01/01/09	0.002
6	C5810419	CODO 90° -3/8" SIT S/R.0906252	NO	AL	01/01/09	0.054
7	C5812659	INY.D.120GLP.L.550/GN.L.300	NO	LATON	04/09/08	0.012
7	C5812679	INY.D.180 GN QUEMADOR L.550	NO	LATON	04/09/08	0.012
1	C5815159	PORTAINYECTOR COMPLETO	NO	LATON	01/01/09	0.058
3	C5815359	TUERCA+BICONO D.6 M10X1	NO	LATON	01/01/09	0.006
4	C5820049	TERMOPAR LISO M9X1 L 320	NO	CU	01/01/09	0.018
2	C6440489	CUBETA GN 2/8-65	NO	INOX	19/11/07	0.555
3	T06030	TUBO AL D.6 L.300	NO	AL 99.7%	13/05/09	0.009
1	T10030	TUBO AL D.10 L.300	NO	AL 99.7%	13/05/09	0.031
2	T10075	TUBO AL D.10 L.750	NO	AL 99.7%	13/05/09	0.013



FAMILIA: COCINAS 2008

FECHA: 19/01/11

MODELO: 3684S

PESO(Kg): 264.758

DENOMINACION:
FRYTOP GAS CROMO DURO 2000X900

ESCALA:
1/20

MATERIAL:
INOX

CODIGO:
3684S



Applus®
LGA1
Organismo
Notificado
0370

AENOR
Organismo
Notificado
0099



TOLERANCIAS GENERALES: ±0.5 mm

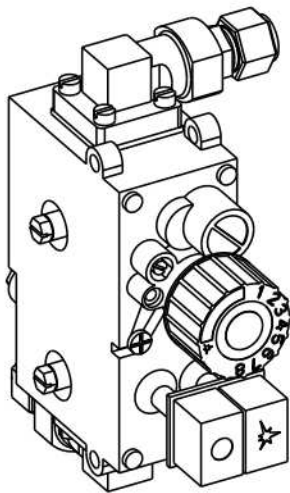

QT	COD	DESCRIPCION
8	1051	TORNILLO ZN M4X15 DIN 84
1	3103	VALVULA MINI SIT
1	3765	MANDO VALV. SIT
2	3781	TUERCA M16X1.5 D.10
2	3782	BICONO D.10 LATON
2	3785	JUNTA VALVULA MINISIT
2	362489P	MACHON D.10 - 3/8" - M16X1.5
2	C5810419	CODO 90° -3/8" SIT S/R.0906252
1	C5815359	TUERCA+BICONO D.6 M10X1

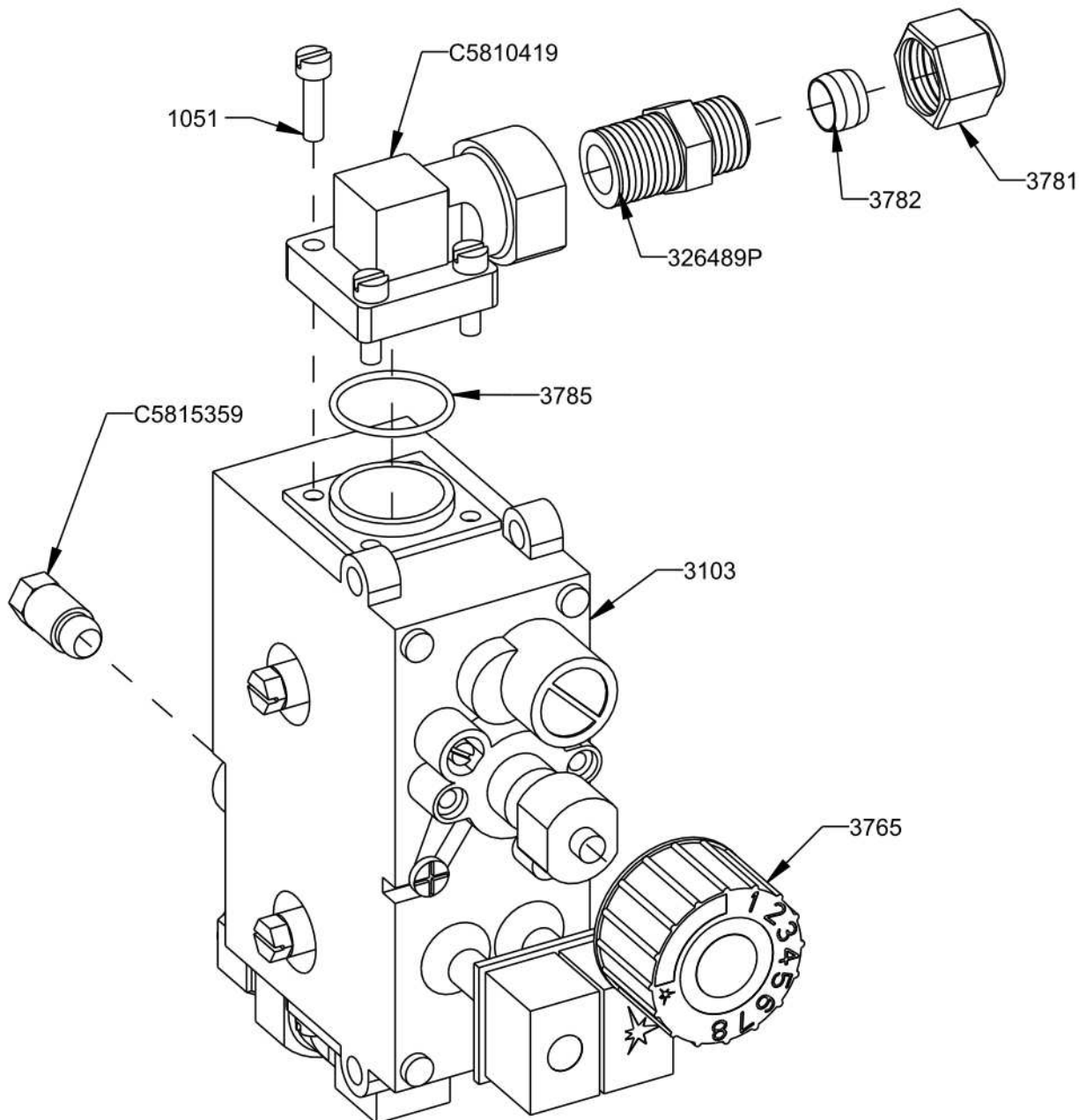

FAMILIA: COCINAS 2008

FECHA: 05/09/08

MODELO: 3611

PESO(Kg): 0.940

DENOMINACION:
VALVULA SIT COMPLETA

ESCALA:
1/2

MATERIAL:
AL

CODIGO:
3103M



Applus®
LGA1
Organismo
Notificado
0370

AENOR
Organismo
Notificado
0099



TOLERANCIAS GENERALES: ±0.5 mm

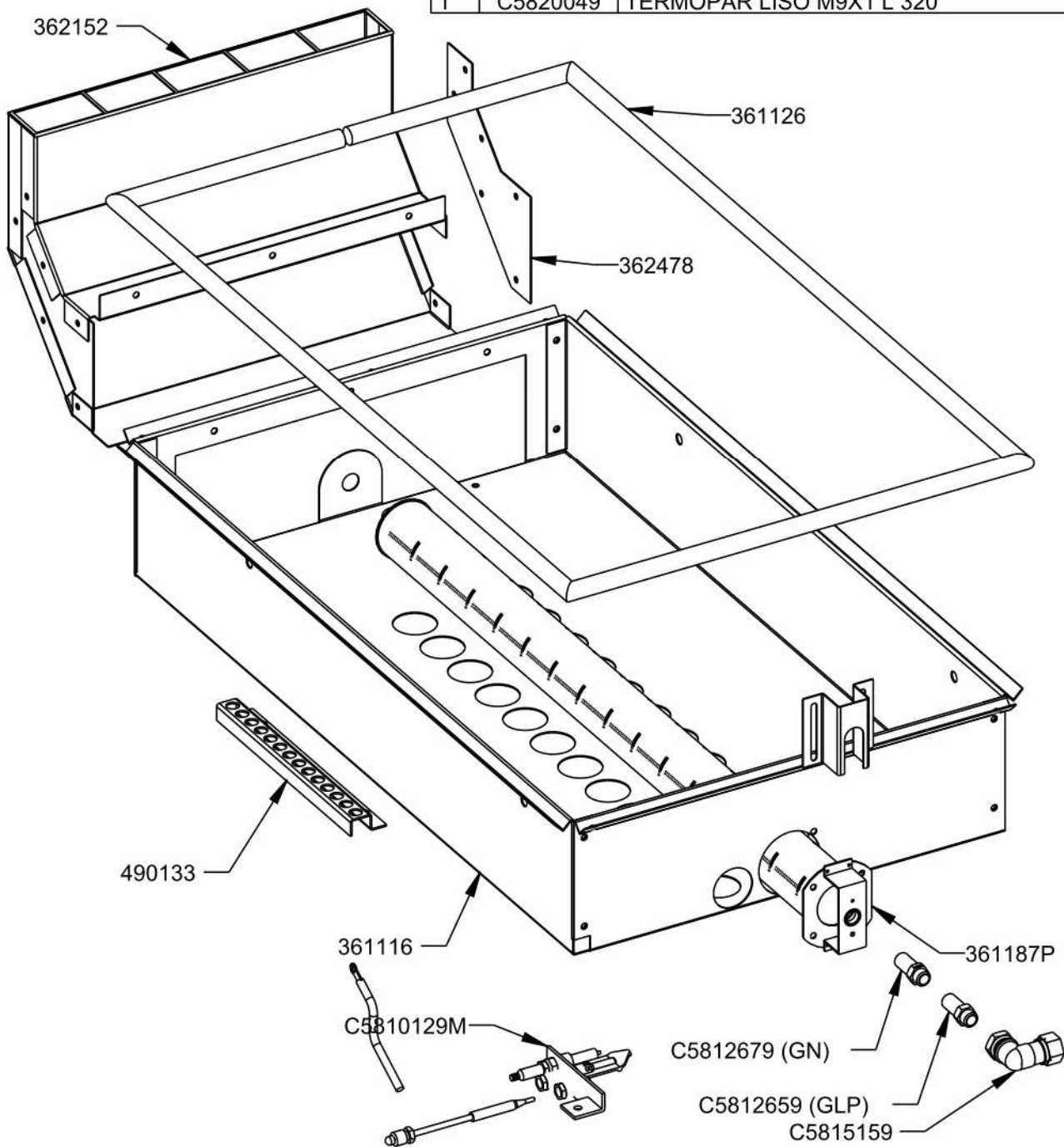
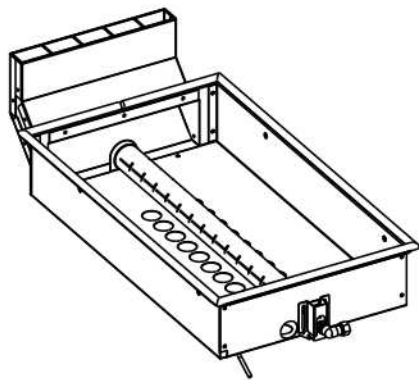

QT	COD	DESCRIPCION
1	2193	CABLE PIEZO L=370
1	300184	AIREADOR QUEMADOR
1	361116	DEFLECTOR FRYTOP 400X900
1	361126	BURLETE CERAM.400x900-C6580179
1	362152	SALIDA VAHOS FT400
2	362478	TAPETA LATERAL DEFLECTOR
1	490133	PROTECTOR BULBO
1	361187P	QUEMADOR TUBULAR D.40 L.550
1	C5810129M	PILOTO POLIDORO COMPLETO
1	C5812659	INY.D.120GLP.L.550/GN.L.300
1	C5812679	INY.D.180 GN QUEMADOR L.550
1	C5815159	PORTAINYECTOR COMPLETO
1	C5820049	TERMOPAR LISO M9X1 L 320



FAMILIA: COCINAS 2008

FECHA: 28/01/11

MODELO: 3611

PESO(Kg): 3.958

DENOMINACION:
DEFLECTOR MONTADO 400X900

ESCALA:
1/4

MATERIAL:
INOX

CODIGO:
361116M



Applus®
LGA1
Organismo
Notificado
0370

AENOR
Organismo
Notificado
0099



TOLERANCIAS GENERALES: ± 0.5 mm

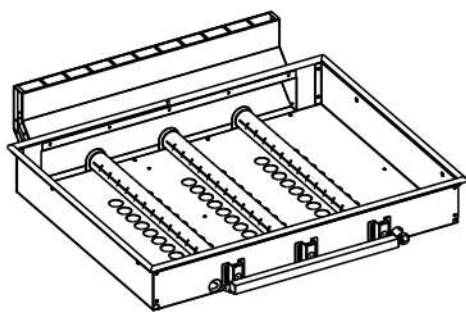

QT	COD	DESCRIPCION
1	3781	TUERCA M16X1.5 D.10
1	3782	BICONO D.10 LATON
3	300184	AIREADOR QUEMADOR
2	300388	CORRELLAMAS
1	361416	DEFLECTOR FRYTOP 800X900
1	361426	BURLETE CERAM.800X900-C6580179
1	362452	SALIDA VAHOS FT800
2	362478	TAPETA LATERAL DEFLECTOR
1	490133	PROTECTOR BULBO
3	361187P	QUEMADOR TUBULAR D.40 L.550
1	362886PC	COLECTOR 3 SALIDAS
1	C5810129M	PILOTO POLIDORO COMPLETO
3	C5812659	INY.D.120GLP.L.550/GN.L.300
3	C5812679	INY.D.180 GN QUEMADOR L.550

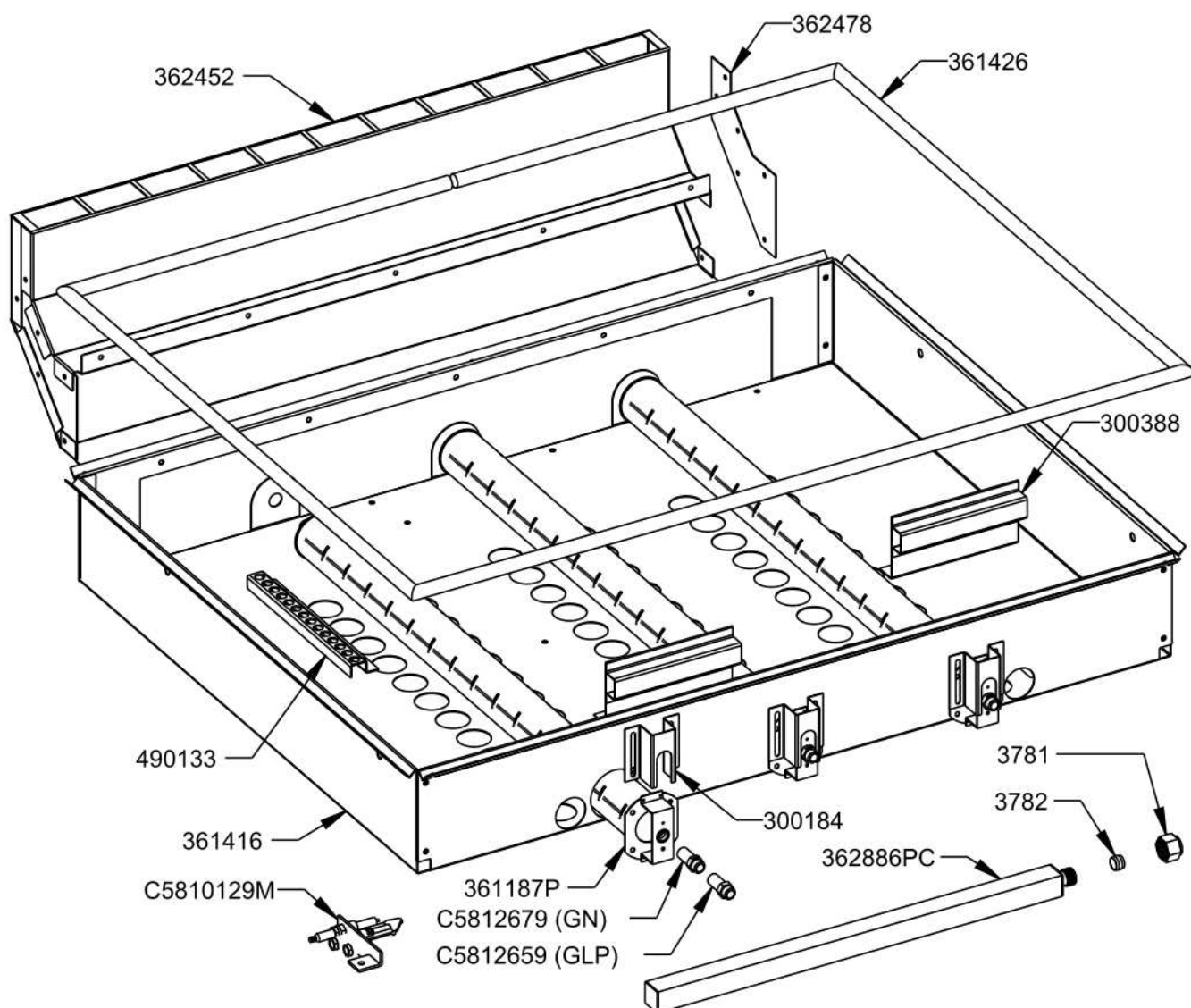

FAMILIA: COCINAS 2008

FECHA: 17/01/11

MODELO: 3683

PESO(Kg): 8.296

DENOMINACION:
DEFLECTOR MONTADO 1200X900

ESCALA:
1/5

MATERIAL:
INOX

CODIGO:
368316M



Applus®
LGA1
Organismo
Notificado
0370

AENOR
Organismo
Notificado
0099



TOLERANCIAS GENERALES: ±0.5 mm

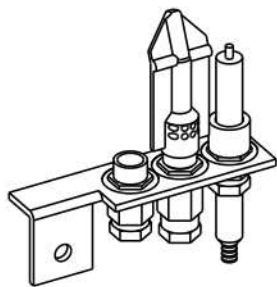

ESCALA 1/2

QT	COD	DESCRIPCION
1	A1018999	BICONO PILOTO
1	C5810139	BUJIA
1	C5810169	INY.PILOTO GLP (22) 1 AGUJ.
1	C5810159	INY.PILOTO GN (27.2) 2 AGUJ.
1	C5810129	PILOTO POLIDORO
1	A1018996	RACORD BUJIA
1	A1018997	RACORD PILOTO
1	A1018998	RACORD TERMOPAR

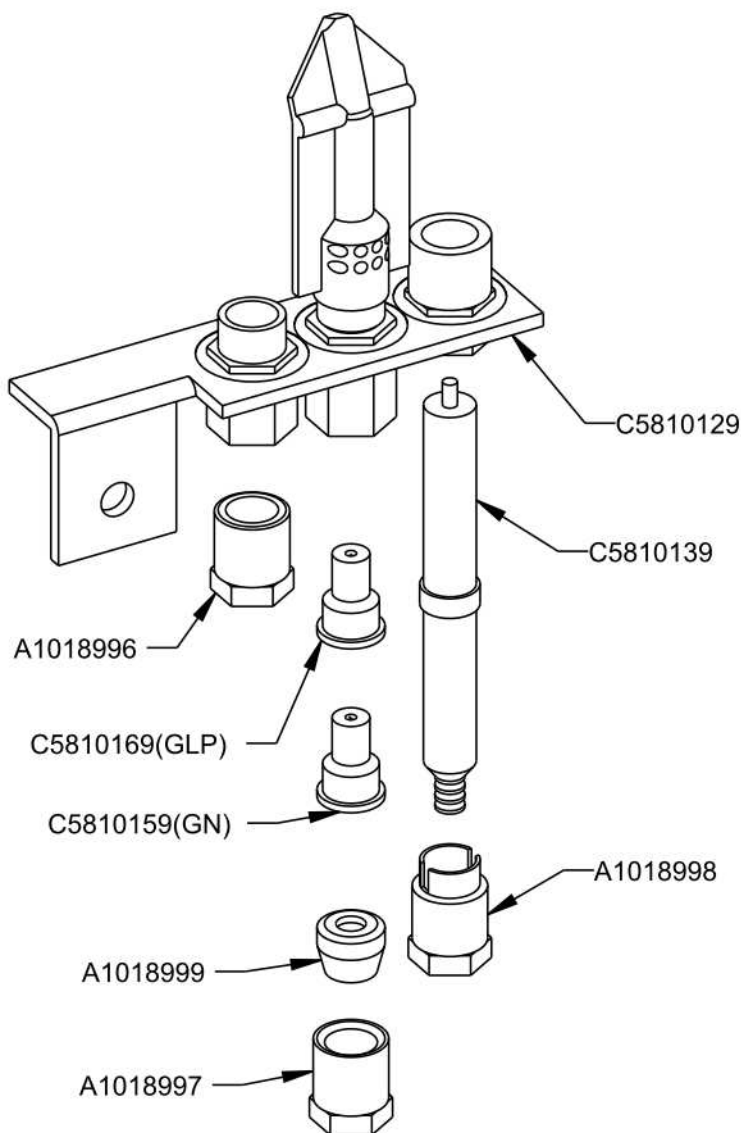

FAMILIA: COCINAS 2008

FECHA: 04/01/11

MODELO: 3611

PESO(Kg): 0.074

DENOMINACION:
PILOTO POLIDORO COMPLETO

ESCALA:
1/1

MATERIAL:
FE

CODIGO:
C5810129M