



CB 955

LIST OF THE EXPLODED VIEWS



SHELL ASSY

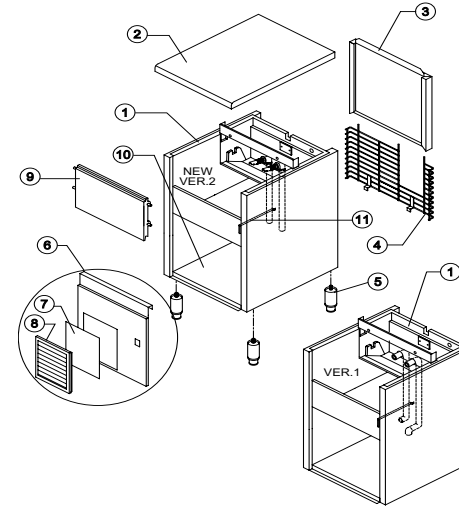

COOLING SYSTEM

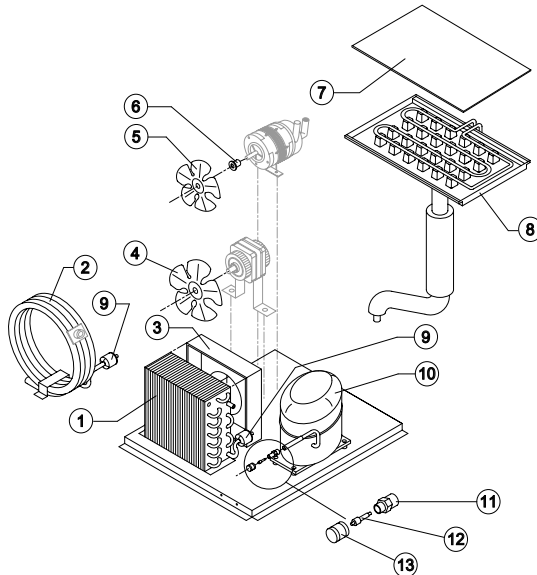

HYDRAULIC CIRCUIT

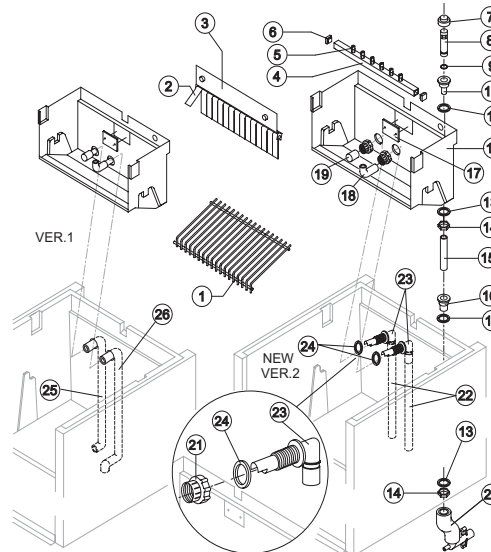

ELECTRIC PARTS

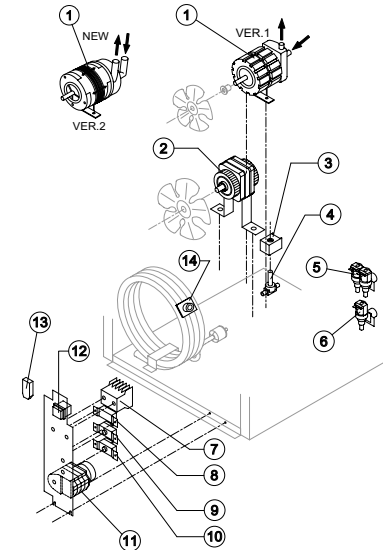

Rev. 2 - 10/2/2003

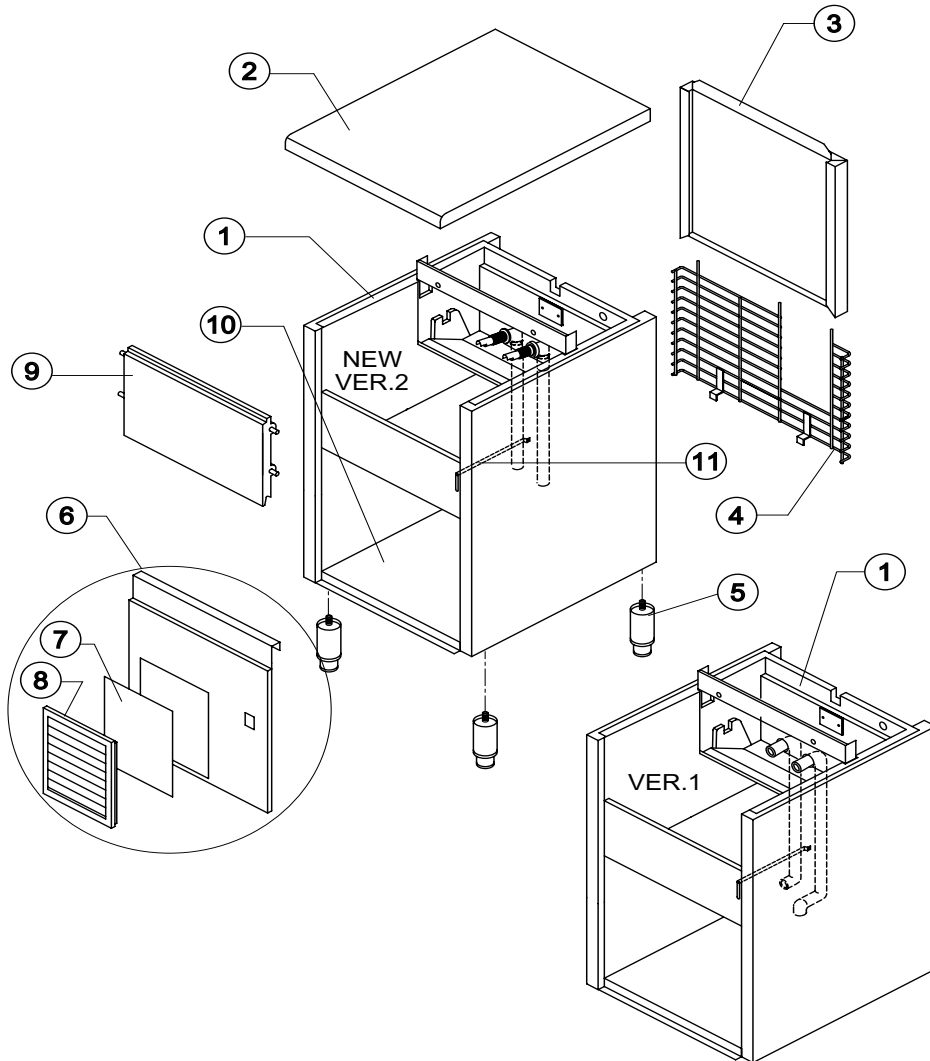

Rev. 2 - 10/2/2003

Ref.	Spare Description	Code
1	Foamed Cabinet Assy	See Table
2	Top Assy	C22673
3	Back Panel Assembly	C22268
4	Rear Grid	D12015
5	Stainless Steel Foot Adjustable	Current Version
5	ABS Foot	Fino a Matr. 142209
6	Front Grid Panel	Current Version
6	Front Panel	Till s/n. 29519
7	Filtering Panel	18106
8	Grid+Frame	C10205
9	Door Assy	C10275
10	Base Plate	Current Version
10	Base Plate	Till s/n. 142209
11	BulbThermostat Pipe	Current Version
11	BulbThermostat Pipe	Till s/n. 94222

Ref. 1 - Foamed Cabinet Assy
Version 1

Kind of Cube	Code
18 g. (Standard)	C11040/E
33 g. (Big)	C11040/E
13 g. (Small)	C11040/ED

Ref. 1 - Foamed Cabinet Assy
Version 2

Condensation	Code
Air	C11040A
Water	C11040W

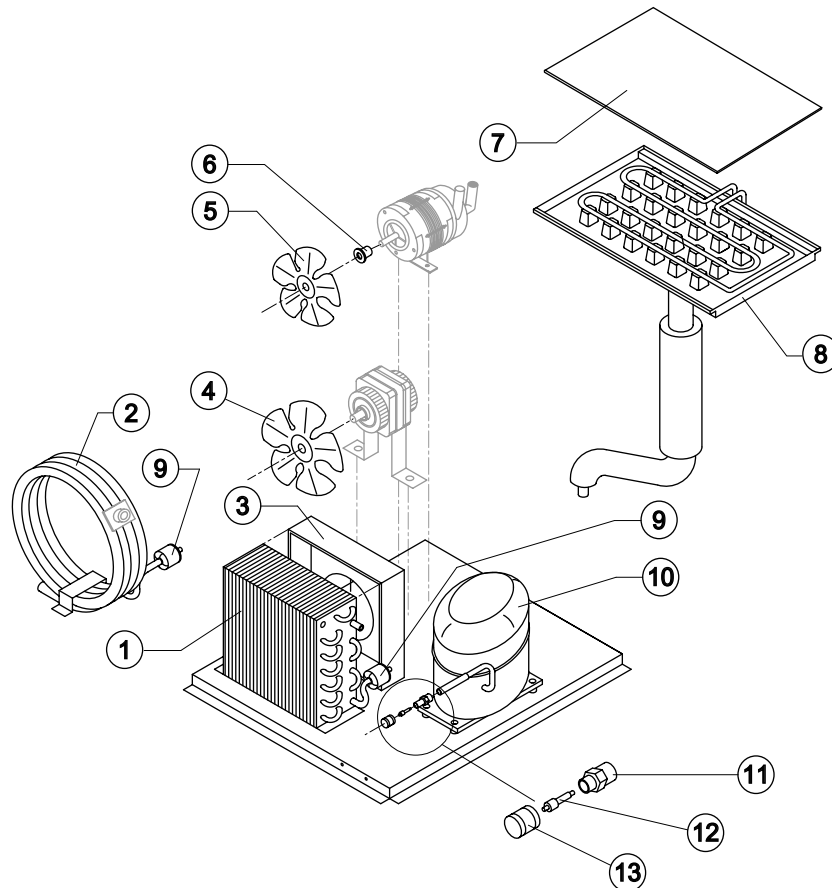

Common Parts

Ref.	Spare Description	Code
5	Suction Impeller	10213
6	Hub+Washer+Screw	10014
7	Evaporator Cover	10039
8	Evaporator	See Table
9	Solid Core Drier	14089
10	Compressor	See Table
11	Vacuum Charge Valve Body	14007
12	Vacuum Charge Valve Device	14005
13	Vacuum Charge Valve Plug	14006

Parts for Air-Cooled Version Only

Ref.	Spare Description	Code
1	Air Condenser	Current Version
1	Air Condenser	Till s/n 27646
3	Air Condenser Conveyor	10163
4	Suction Impeller	20031

Parts for Water-Cooled Version Only

Ref.	Spare Description	Code
2	Water Condenser	14034
4	Suction Impeller	10213

Ref. 8 - Evaporator

Kind of Cube	Code
18 g. (Standard)	D10047
33 g. (Big)	D10090
13 g. (Small)	D10418

Ref. 10 - Compressor

Tension	Refr. R404A	Refr. R22
220/240V 50 Hz	23444	23407
220/230V 60 Hz	23504	23519
110/115V 60 Hz	23553	23520



Ref. 8 - For ice makers made in version 1 (for "small size" ice cube only) ask, beside the Evaporator, also the Evaporator Support.



CB 955

HYDRAULIC CIRCUIT

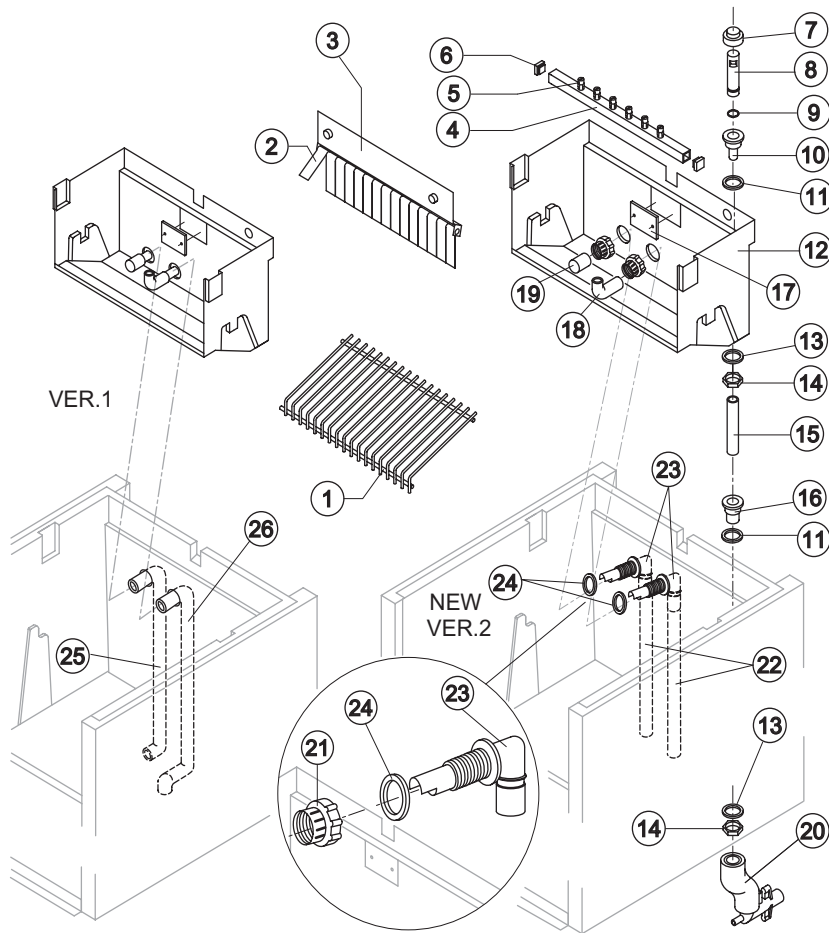

Common Parts

Ref.	Spare Description	Code
1	Ice Cubes Slide	See Table
2	Flag	10005
3	Flags Support Assy	C22059
4	Sprayers Bar Assembly	See Table
5	Sprayer	D20002
6	Sprayers Bar Plug	10012
7	Overflow Cap	10305
8	Overflow Pipe	10133
9	OR Gasket for Overflow Pipe	20233
10	Overflow Pipe Nipple	10241
11	Silicone Gasket	13006
12	Inner Basin	10034
13	Semirigid Polyethylene Gasket	13007
14	Bin Discharge Nut	10096
15	Overflow Pipe	Current Version
15	Overflow Pipe	Till s/n 62553
16	Plastic Nipple Water Outlet	10007
17	Slide Keep Plate	10009
18	Sprayers Feeding Pipe	13005
19	Pump Suction Filter	20005
21	Fittings Locking Ring	Version 2
21	Fittings Locking Ring	10405
22	Pump Suction/Delivery Pipe	Version 2
22	Pump Suction/Delivery Pipe	13141
23	Fitting of the Pump Suction/Delivery Pipes	Version 2
23	Fitting of the Pump Suction/Delivery Pipes	10404
24	Gasket for Suction Line/Pump Delivery	Version 2
24	Gasket for Suction Line/Pump Delivery	13143
25	Pump Suction Pipe	Version 1
25	Pump Suction Pipe	13059
26	Pump Delivery Pipe	Version 1
26	Pump Delivery Pipe	13058

Ref. 1 - Ice Cubes Slide

Kind of Cube	Code
18 g. (Standard)	D12017
33 g. (Big)	D12031
13 g. (Small)	D12039

Ref. 4 - Sprayers Bar Assy

Kind of Cube	Code
18 g. (Standard)	C20058
33 g. (Big)	C20156
13 g. (Small)	C20190

Parts for Air Cooled Version Only

Ref.	Spare Description	Code
20	Discharges Manifold	C10006

Parts for Water Cooled Version Only

Ref.	Spare Description	Code
20	Discharges Manifold	C26452

Rev. 2 - 10/2/2003



CB 955

ELECTRIC PARTS

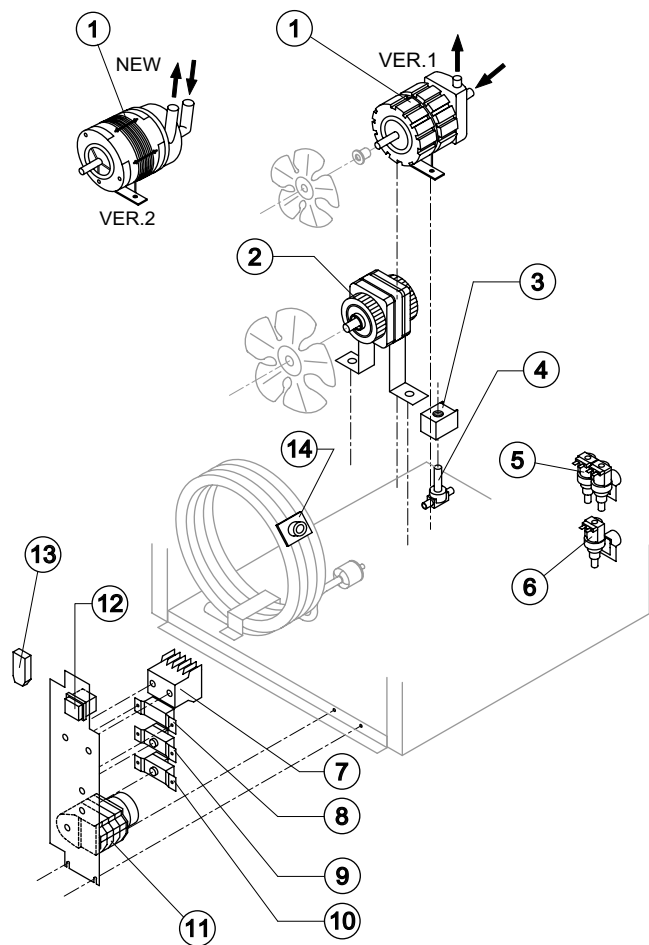

Common Parts

Ref.	Spare Description	Code
1	Pump	See Table -
2	Fan Motor	See Table -
3	Hot Gas Coil	See Table -
4	Hot Gas Valve Body	Current Version 20410
4	Hot Gas Valve Body	Till s/n. 27646 20409
7	Contactor	Only 110V 60 Hz 23595
8	Condenser Pressure Switch	23175
9	Bin Thermostat	23005
10	Evaporator Thermostat	23591
11	Timer	See Table -
12	Green Light Switch	23327

Parts for Air-Cooled Version Only

Ref.	Spare Description	Codice
6	Inlet Watervale 1 Way	See Table -
13	Anti Radio Interference Filter	Only 220V 50 Hz 23459

Parts for Water-Cooled Version Only

Ref.	Spare Description	Codice
5	Inlet Watervale 2 Ways	See Table -
13	Anti Radio Interference Filter	Only 220V 50 Hz 23457
14	Safety Thermostat	C23114

Ref. 1 - Pump

Tension	Version 1	Version 2
220/240V 50 Hz	23002	23377
220/230V 60 Hz	23002	23377
110/115V 60 Hz	23264	23663

Ref. 2 - Fan Motor

Tension	Air	Water
220/240V 50 Hz	23067	23029
220/230V 60 Hz	23580	23029
110/115V 60 Hz	23393	23265

Ref. 3 - Hot Gas Coil

Tension	Code
220/240V 50 Hz	23091
220/230V 60 Hz	23091
110/115V 60 Hz	23256

Ref. 5 - Inlet Watervale 2 Ways

Tension	Code
220/240V 50 Hz	23010
220/230V 60 Hz	23010
110/115V 60 Hz	23261

Ref. 6 - Inlet Watervale 1 Way

Tension	Code
220/240V 50 Hz	23001
220/230V 60 Hz	23001
110/115V 60 Hz	23260

Ref. 11 - Timer

Tension	18 g Cube	33 g Cube	13 g Cube
220/240V 50 Hz	23222	23248	23247
220/230V 60 Hz	23248	23396	23447
110/115V 60 Hz	23259	23397	23258

Rev. 2 - 10/2/2003