

POS.	CODICE CODE KODE	POS.	CODICE CODE KODE	POS.	CODICE CODE KODE	POS.	CODICE CODE KODE
1	02 50 07	33	11 90 02	62	43 50 01		
2	{ 21 60 02 21 60 03	34	99 30 21	63	43 70 31		
3/4	44 70 07	35	11 00 02	64	pag. 93		
5/6	44 70 08	36	14 00 06	65	99 90 31		
7	20 80 03	37	13 80 01	66	14 20 11		
8	{ 20 80 01 21 30 02	38	98 40 02	67	14 20 01		
9	21 20 01	39	46 80 29	68	43 70 38		
10	23 60 07	40	{ 45 60 20 43 70 19	69	46 30 04		
11	pag. 90	41	12 70 10	70	10 80 04		
12	22 40 02	42	99 90 32	71	00 40 08		
13	99 90 26	43	43 70 27	72	20 30 30		
14	12 30 02	44	45 60 16	73	20 40 14		
15	99 40 01	45	99 00 29	74	42 50 01		
16	{ 48 00 15 48 00 16	46	43 70 25	75	46 10 02		
17	02 00 06	47	45 80 01	76	11 70 01		
18	02 10 11	48	99 90 08	77	14 30 04		
19	02 10 04	49	21 80 02	78	99 10 01		
20	99 90 04	50	pag. 101	79	43 70 07		
21	32 20 03	51	12 70 08	80	40 69 99		
22	99 90 29	52	12 70 09	82	43 70 34		
23	99 90 25	53	{ 98 70 01 98 70 05	83	42 90 11		
24	31 90 02	54	{ 20 10 02 20 10 11	84	45 60 16		
25	12 10 12	55	14 30 13	85	48 00 05		
26	99 00 27	56	12 10 17	86	99 30 20		
27	99 00 28	57	14 30 05	87	43 70 30		
28	99 90 30	58	98 20 09	88	48 00 06		
29	14 00 02	59	{ 23 00 07 23 00 21	89	43 70 34		
30	11 90 01	60	43 70 28	90	42 90 12		
31	11 00 05	61	41 50 01				
32	14 00 03						

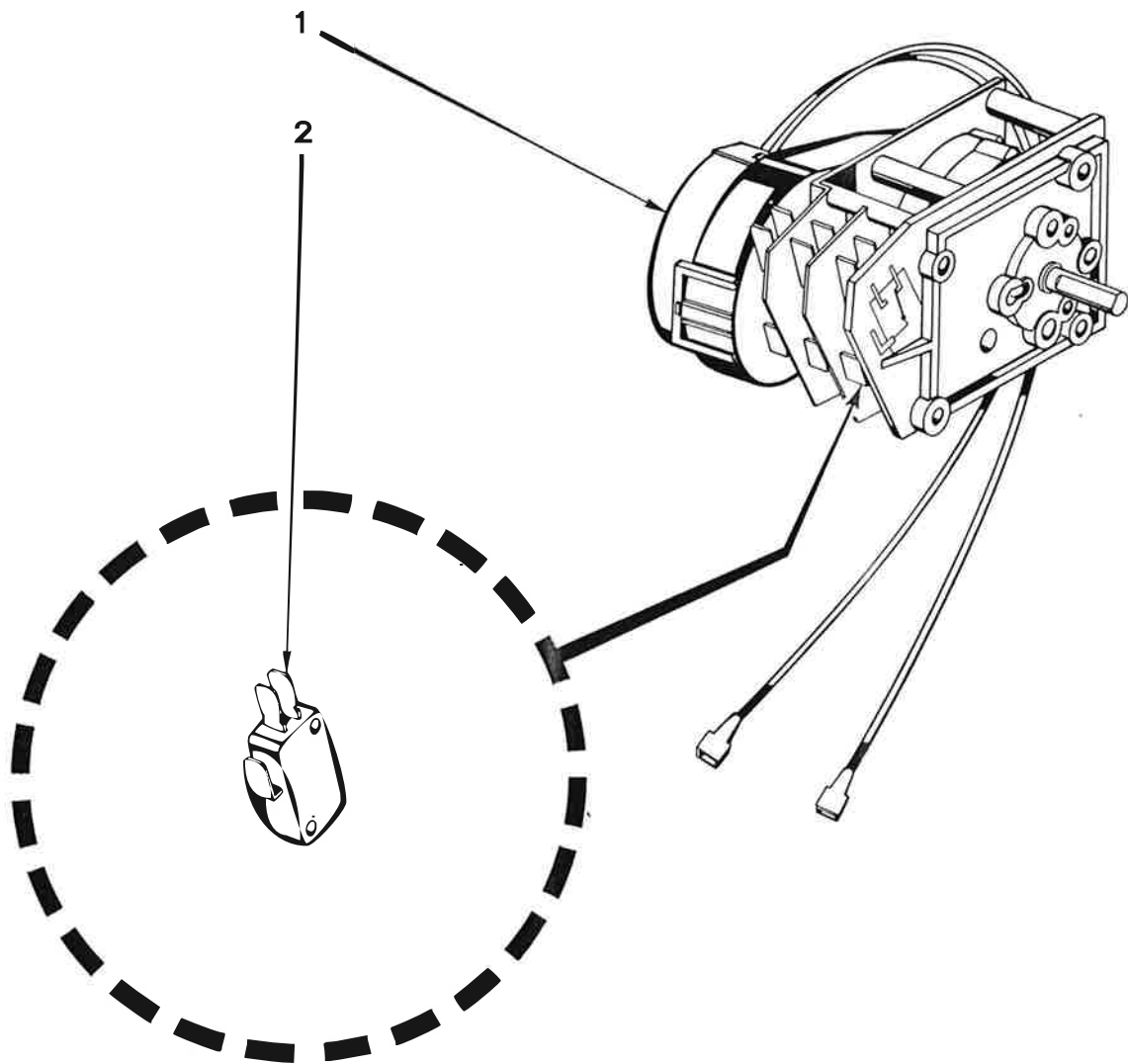

POS.	CODICE CODE KODE	DESCRIZIONE - DESCRIPTION - BESCHREIBUNG
1	23 80 25	Timer ciclo 180" - Cronel 2C Cycle timer 180" - Cronel 2C Programmateur cycle 180" - Cronel 2C Programmschalter 180" - Cronel 2C 220/50/1 Mod. R 495 - 497
1	23 80 01	Timer ciclo 180" - Crouzet 3C Cycle timer 180" - Crouzet 3C Programmateur cycle 180" - Crouzet 3C Programmschalter 180" - Crouzet 3C 220/50/1 Mod. R 499 - 501 - 503 - 505 - 507 - 509 - 511 - 704 - 706 - 708 - S 641 - 643 Mod. S 870 fino matricola n° 64902 till serial no. 64902 au matricule n° 64902 bis Maschinen-Nr. 64902
1	23 80 24	Timer ciclo 180" - Cronel 3C Cycle timer 180" - Cronel 3C Programmateur cycle 180" - Cronel 3C Programmschalter 180" - Cronel 3C 220/50/1 Mod. R 499 - 501 - 503 - 505 - 507 - 509 - 511 - 704 - 706 - 708 - S 641 - 643 Mod. S 870 fino matricola n° 64902 till serial no. 64902 au matricule n° 64902 bis Maschinen-Nr. 64902
1	23 80 05	Timer ciclo 180" - Cronel 3C Cycle timer 180" - Cronel 3C Programmateur cycle 180" - Cronel 3C Programmschalter 180" - Cronel 3C 220-240/50/1 Mod. R 499 - 501 - 503 - 505 - 507 - 509 - 511 - 704 - 706 - 708 - S 641 - 643 Mod. S 870 fino matricola n° 64902 till serial no. 64902 au matricule n° 64902 bis Maschinen-Nr. 64902
1	23 80 16	Timer ciclo 180" - Cronel 3C Cycle timer 180" - Cronel 3C Programmateur cycle 180" - Cronel 3C Programmschalter 180" - Cronel 3C 220/60/1 Mod. R 499 - 501 - 503 - 505 - 507 - 509 - 511 - 704 - 706 - 708 - S 641 - 643 Mod. S 870 fino matricola n° 64902 till serial no. 64902 au matricule n° 64902 bis Maschinen-Nr. 64902

POS.	CODICE CODE KODE	DESCRIZIONE - DESCRIPTION - BESCHREIBUNG
1	23 80 09	Timer pompa scarico 180" - Cronel 4C Drain pump timer 180" - Cronel 4 Programmateur pompe vidange 180" - Cronel 4C Laugenpumpe-Programmschalter 180" - Cronel 4C 220/50/1 Mod. R 501 - 505 - 509 - 704 - 706 - 708 - S 641 Mod. S 870 fino matricola n° 64902 till serial no. 64902 au matricule n° 64902 bis Maschinen-Nr. 64902
2	21 80 09	Micro timer Cronel Microtimer Cronel Minirupteur programmeur Cronel Mikroschalter Cronel

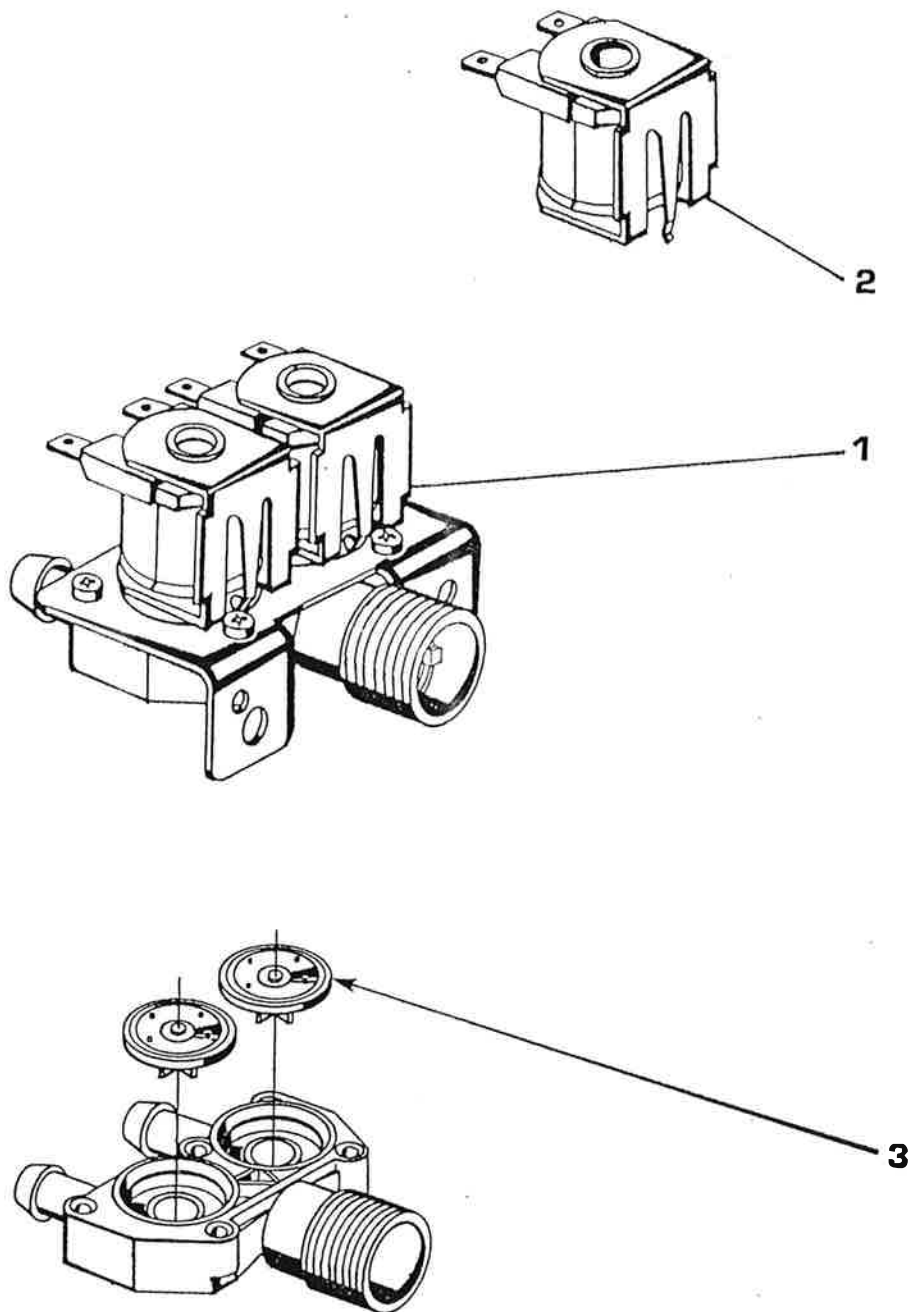

POS.	CODICE CODE KODE	DESCRIZIONE - DESCRIPTION - BESCHREIBUNG
1	24 00 06	Valvola - Elbi - 1 via 90° Solenoid valve - Elbi - 1 way 90° Vanne - Elbi - 1 bobine 90° Einweg - Einlassmagnetventil - Elbi - 90° 220-240/50-60/1 Mod. R 495
1	24 00 05	Valvola - Elbi - 1 via 180° Solenoid valve - Elbi - 1 way 180° Vanne - Elbi - 1 bobine 180° Einweg - Einlassmagnetventil - Elbi - 180° 220-240/50-60/1 Mod. R 704 - 706
1	24 00 03	Valvola - 2 vie 180° Solenoid valve - 2 ways 180° Vanne - 2 bobines 180° Zweiweg - Einlassmagnetventil - 180° 220-240/50-60/1 Mod. R 497 - 499 - 501 - 505 - 509 - S 641
1	24 00 02	Valvola - 3 vie 180° Solenoid valve - 3 ways 180° Vanne - 3 bobines 180° Dreiweg - Einlassmagnetventil - 180° 220-240/50-60/1 Mod. R 503 - 507 - 511 - S 643
1	24 00 08	Valvola ottone piccola portata Brass solenoid valve - small capacity Vanne laiton - petite Kleines Einlassmagnetventil aus Messing 220-240/50-60/1 Mod. R 708
1	24 00 07	Valvola ottone grande portata Brass solenoid valve - big capacity Vanne laiton - grande Grosses Einlassmagnetventil aus Messing 220-240/50-60/1 Mod. S 870 fino matricola n° 64902 till serial no. 64902 au matricule n° 64902 bis Maschinen-Nr. 64902

OS.	CODICE CODE KODE	DESCRIZIONE - DESCRIPTION - BESCHREIBUNG
2	20 10 06	Bobina valvola Coil for solenoid valve Bobine pour vanne Spule für Einlassmagnetventil
2	20 10 08	Bobina valvola ottone piccola portata Coil for brass solenoid valve - small capacity Bobine vanne laiton petite Spule für kleines Einlassmagnetventil aus Messing
2	20 10 07	Bobina valvola ottone grande portata Coil for brass solenoid valve - big capacity Bobine vanne laiton grande Spule für grosses Einlassmagnetventil aus Messing
3	29 90 22	Membrana valvola ottone grande portata Membrane for brass solenoid valve - big capacity Membrane vanne laiton grande Membran für grosses Einlassmagnetventil aus Messing

POMPA
WASH PUMP
POMPE
ELEKTROPUMPE

mod. R:
509 - 511 - 704

102



10/87

F PA
WASH PUMP
POMPE
ELEKTROPUMPE

mod. R:
509 - 511 - 704

103

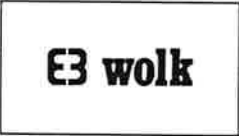
10/87

POS.	CODICE CODE KODE	DESCRIZIONE - DESCRIPTION - BESCHREIBUNG	POS.	CODICE CODE KODE	DESCRIZIONE - DESCRIPTION - BESCHREIBUNG
1	13 00 16	Pompa T 20 HP 0,7 Wash pump T 20 HP 0,7 Pompe T 20 HP 0,7 Elektropumpe T 20 HP 0,7 220/50/1 Mod. R 509 - 511 - 704	5	12 40 21	Girante T 20 60 Hz. Impellor T 20 60 Hz. Turbine T 20 60 Hz. Pumpenflügel T 20 60 Hz.
1	13 00 10	Pompa T 20 HP 0,7 Wash pump T 20 HP 0,7 Pompe T 20 HP 0,7 Elektropumpe T 20 HP 0,7 240/50/1 Mod. R 509 - 511 - 704	5	12 40 03	Girante 1296 FIR 50 Hz. Impellor 1296 FIR 50 Hz. Turbine 1296 FIR 50 Hz. Pumpenflügel 1296 FIR 50 Hz.
1	13 00 31	Pompa T 20 HP 0,7 Wash pump T 20 HP 0,7 Pompe T 20 HP 0,7 Elektropumpe T 20 HP 0,7 220/60/1 Mod. R 509 - 511 - 704	6	45 60 24	OR T 20 O-ring T 20 Joint thorique T 20 O-Ring Dichtung T 20
2	20 60 03	Condensatore T 20 1296 FIR Condenser T 20, 1296 FIR Condensateur T 20, 1296 FIR Kondensator T 20, 1296 FIR	6	43 70 44	OR 1296 FIR O-ring 1296 FIR Joint thorique 1296 FIR O-Ring Dichtung 1296 FIR
3	31 50 08	Flangia T 20 Flange int. T 20 Flansque int. T 20 Flansch T 20	7	14 10 02	Tenuta meccanica T 20, 1296 FIR Seal T 20, 1296 FIR Presse etoupe T 20, 1296 FIR Gleitringdichtung T 20, 1296 FIR
3	31 50 03	Flangia + cappello 1296 FIR Flange 1296 FIR Flansque 1296 FIR Flansch 1296 FIR	8	31 40 02	Cuscinetto T 20, 1296 FIR Bearing T 20, 1296 FIR Roulement T 20, 1296 FIR Kugellager T 20, 1296 FIR
4	11 60 10	Corpo pompa T 20 Flange ext. T 20 Flansque ext. T 20 Pumpengehäuse T 20	9	33 50 04	Ventola T 20 Fan T 20 Turbine de refroidissement T 20 Flügel T 20
4	11 60 03	Corpo pompa 1296 FIR Flange ext. 1296 FIR Flansque ext. 1296 FIR Pumpengehäuse 1296 FIR	9	33 50 02	Ventola 1296 FIR Fan 1296 FIR Turbine de refroidissement 1296 FIR Flügel 1296 FIR
5	12 40 08	Girante T 20 50 Hz. Impellor T 20 50 Hz. Turbine T 20 50 Hz. Pumpenflügel T 20 50 Hz.	10	31 30 04	Copriventola T 20 Fan protection T 20 Protection turbine T 20 Flügelschutz T 20
			10	31 30 02	Copriventola 1296 FIR Fan protection 1296 FIR Protection turbine 1296 FIR Flügelschutz 1296 FIR
					

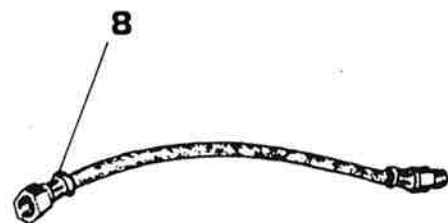
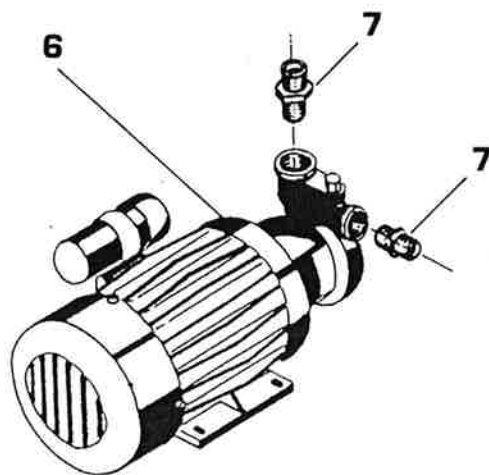
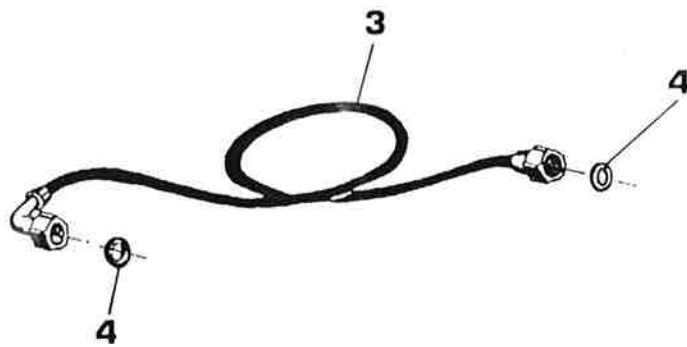
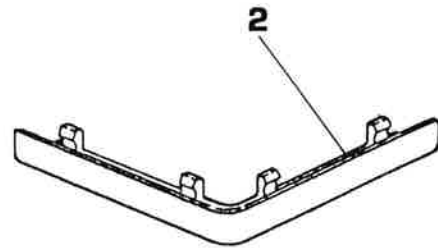
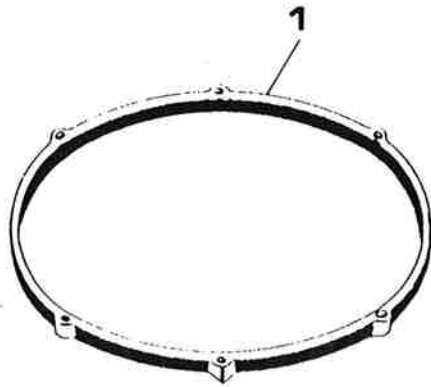

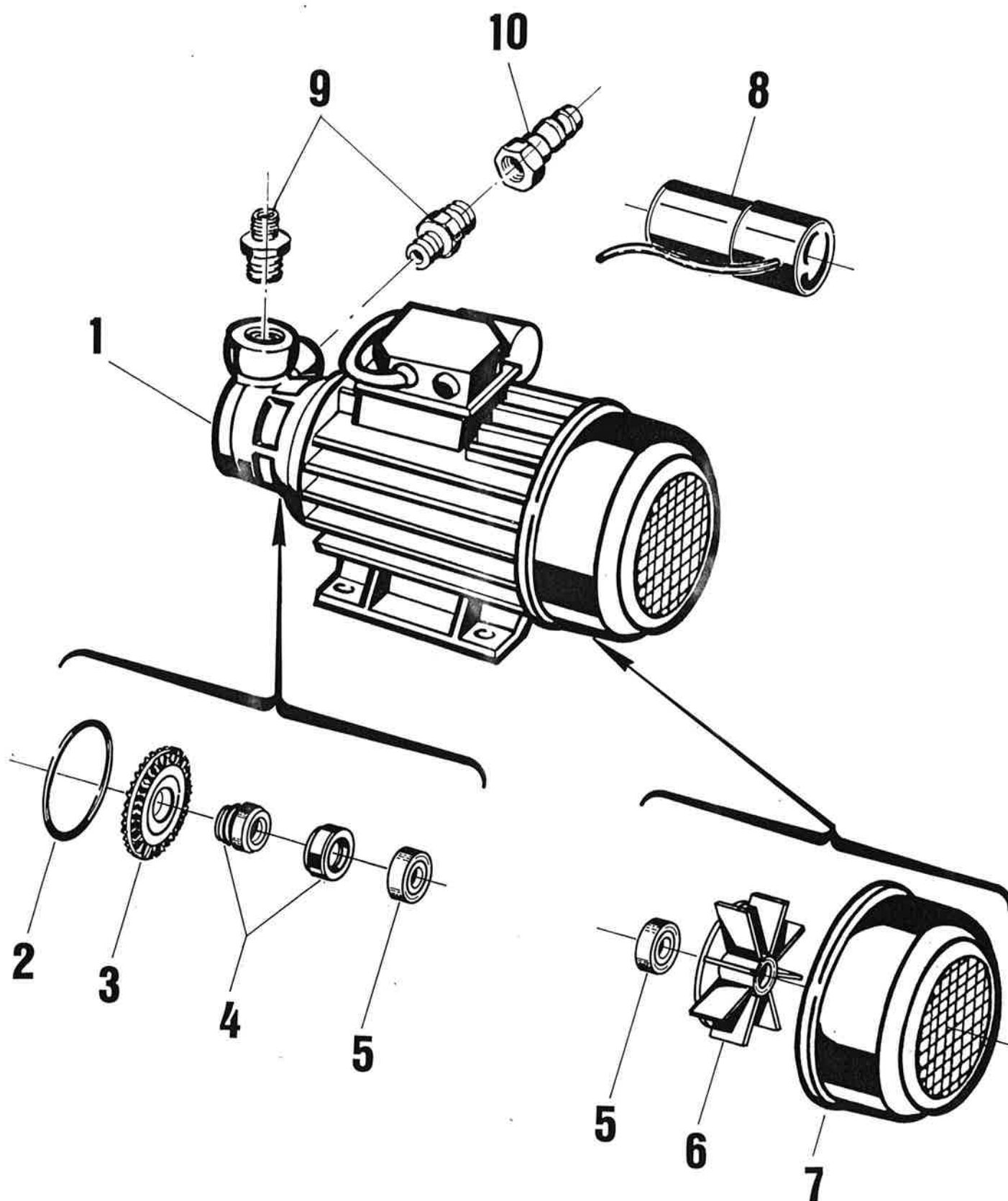

POS.	CODICE CODE KODE	DESCRIZIONE - DESCRIPTION - BESCHREIBUNG	
1	13 00 13	Pompa ausiliaria Dab K 30 HP 0,4 Rinse booster pump Dab K 30 HP 0,4 Pompe rincage Dab K 30 HP 0,4 Nachspülpumpe Dab K 30 HP 0,4	220/50/1 Per tutti i modelli For all the models Tous modeles Für alle Modelle
1	13 00 52	Pompa ausiliaria Dab K 30 HP 0,4 Rinse booster pump Dab K 30 HP 0,4 Pompe rincage Dab K 30 HP 0,4 Nachspülpumpe Dab K 30 HP 0,4	240/50/1 Per tutti i modelli For all the models Tous modeles Für alle Modelle
2	45 60 37	OR K 30 O-ring K 30 Joint thorique K 30 O-Ring Dichtung K 30	
3	12 40 15	Girante K 30 Impellor K 30 Turbine K 30 Pumpenflügel K 30	
4	14 10 02	Tenuta meccanica K 30 Seal K 30 Presse etoupe K 30 Gleitringdichtung K 30	
5	31 40 01	Cuscinetto K 30 Bearing K 30 Roulement K 30 Kugellager K 30	
6	33 50 07	Ventola K 30 Fan K 30 Turbine de refroidissement K 30 Flügel K 30	
7	31 30 08	Copriventola K 30 Fan protection K 30 Protection turbine K 30 Flügelschutz K 30	
8	20 60 01	Condensatore K 30 Condenser K 30 Condensateur K 30 Kondensator K 30	
9	46 80 26	Raccordo K 30 Connection K 30 Raccord K 30 Anschluss K 30	
10	45 30 02	Raccordo pompa ausiliaria Dab K 30 Rinse booster pump connection Dab K 30 Raccord pompe rincage Dab K 30 Nachspülpumpeanschluss Dab K 30	Mod. S 850 - 870 - 950

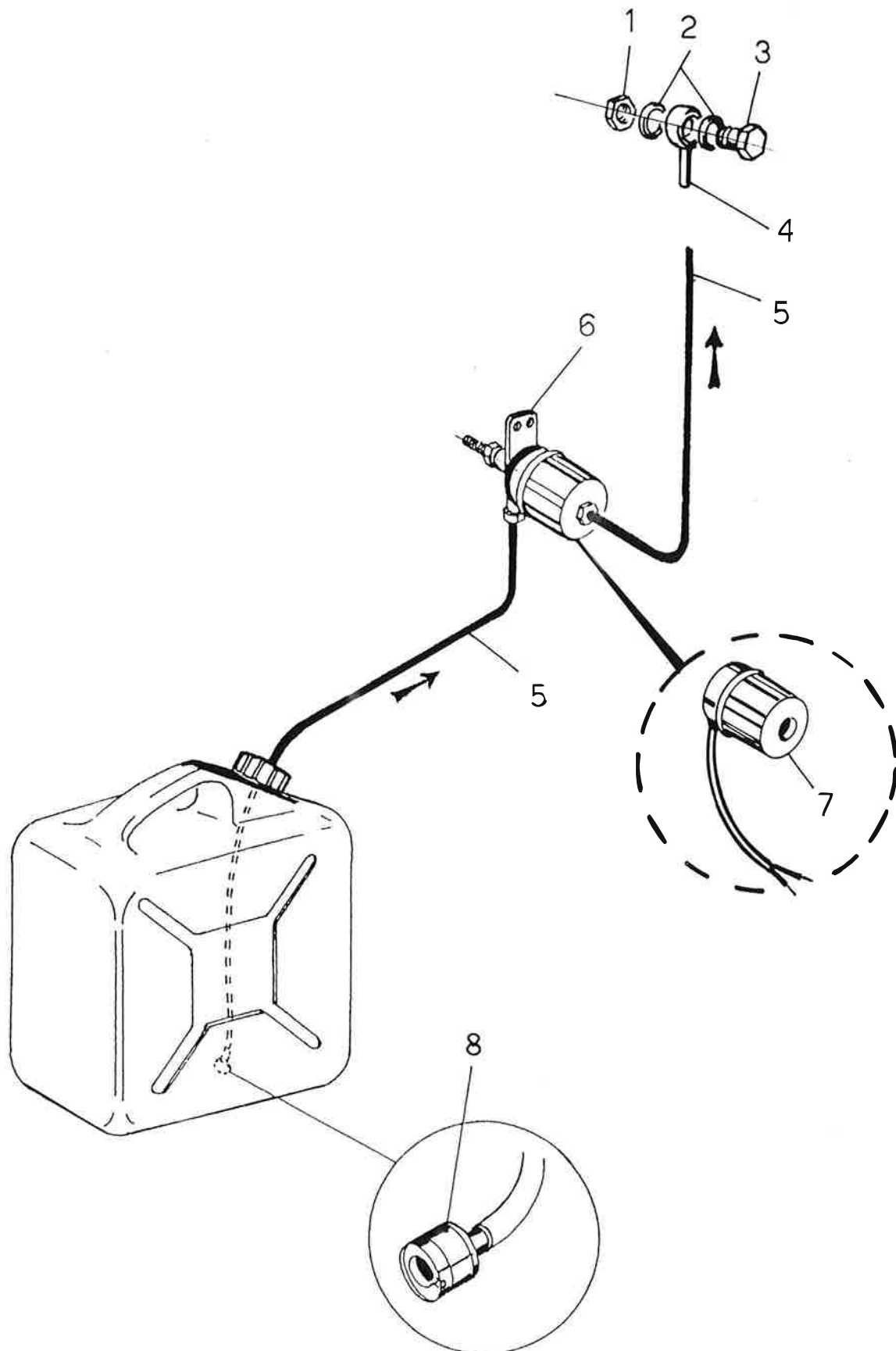



DOSATORE SAPONE
LIQUID DETERGENT DISPENSER
DOSEUR DU PRODUIT DE LAVAGE
SPUELMITTEL-DOSIERGERAET

121

10/87

POS.	CODICE CODE KODE	POS.	CODICE CODE KODE	POS.	CODICE CODE KODE	POS.	CODICE CODE KODE
1	41 70 16						
2	43 70 07						
3	46 80 24						
4	46 80 23						
5	14 30 14						
6	98 70 12						
7	20 10 18						
8	98 60 02						

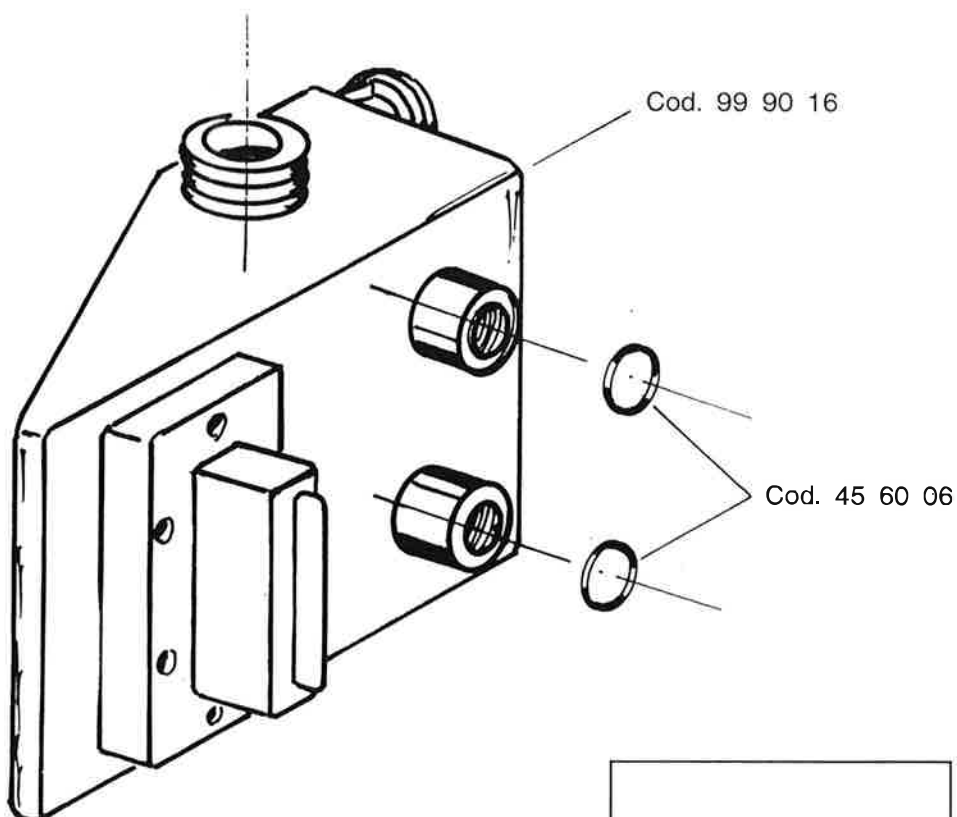
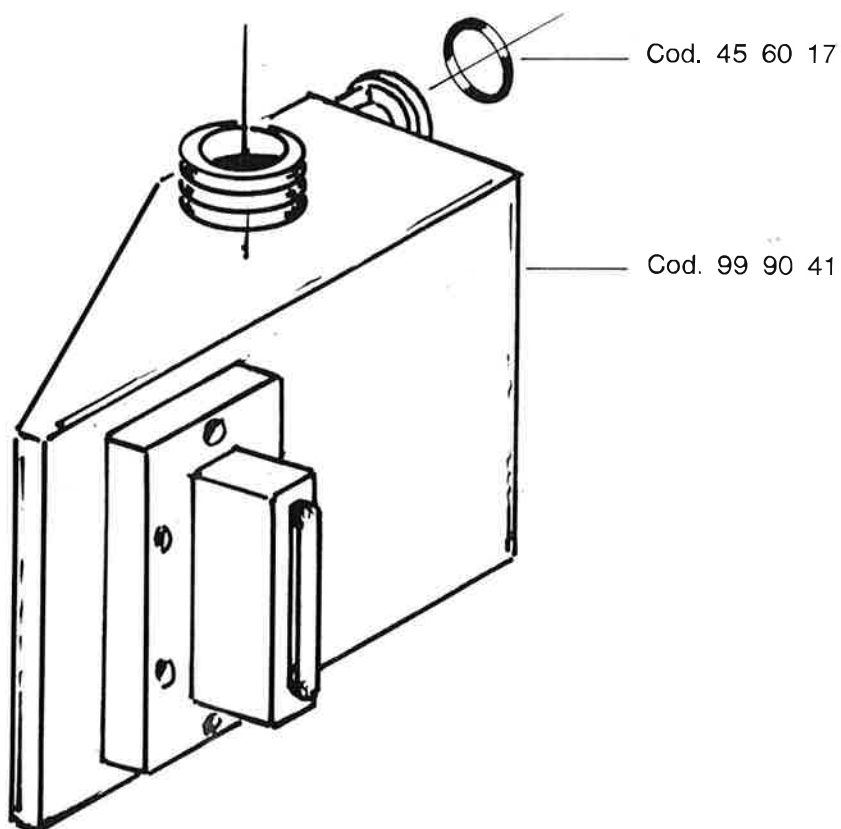

NUOVO
NEW
NOUVEAU
NEU

DA MATRICOLA N° 68473
DE MATRICULE NR. 68473
FROM SERIAL NO. 68473
AB MASCHINEN NR. 68473

E3 wolk

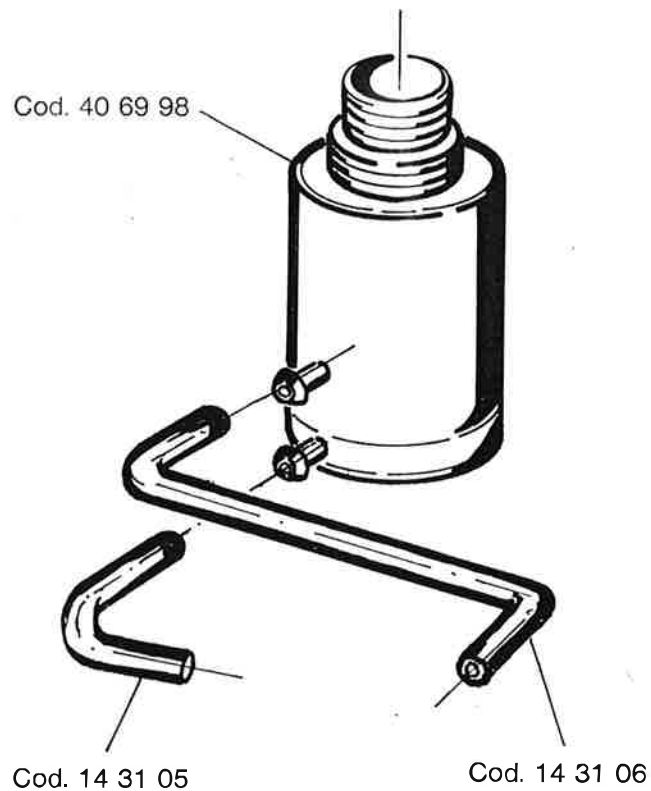
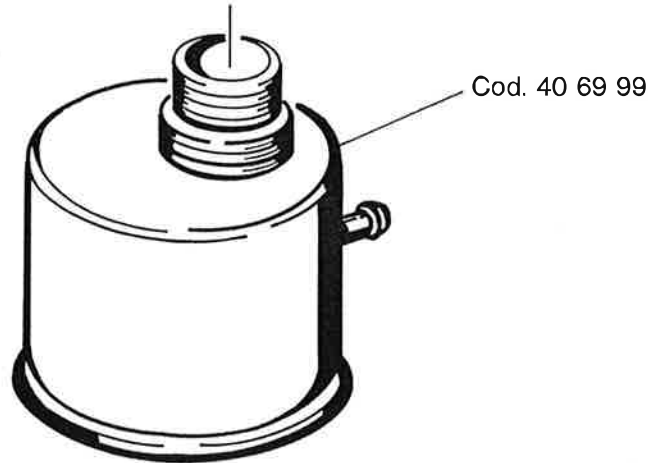

**NUOVO
NEW
NEU
NOUVEAU**

DA MATRICOLA N° 92582
FROM SERIAL NO. 92582
AB MASCHINEN NR. 92582
DU MATRICULE NO. 92582