

ES 50

TAV.54

ASS.TELAIO MOBILE

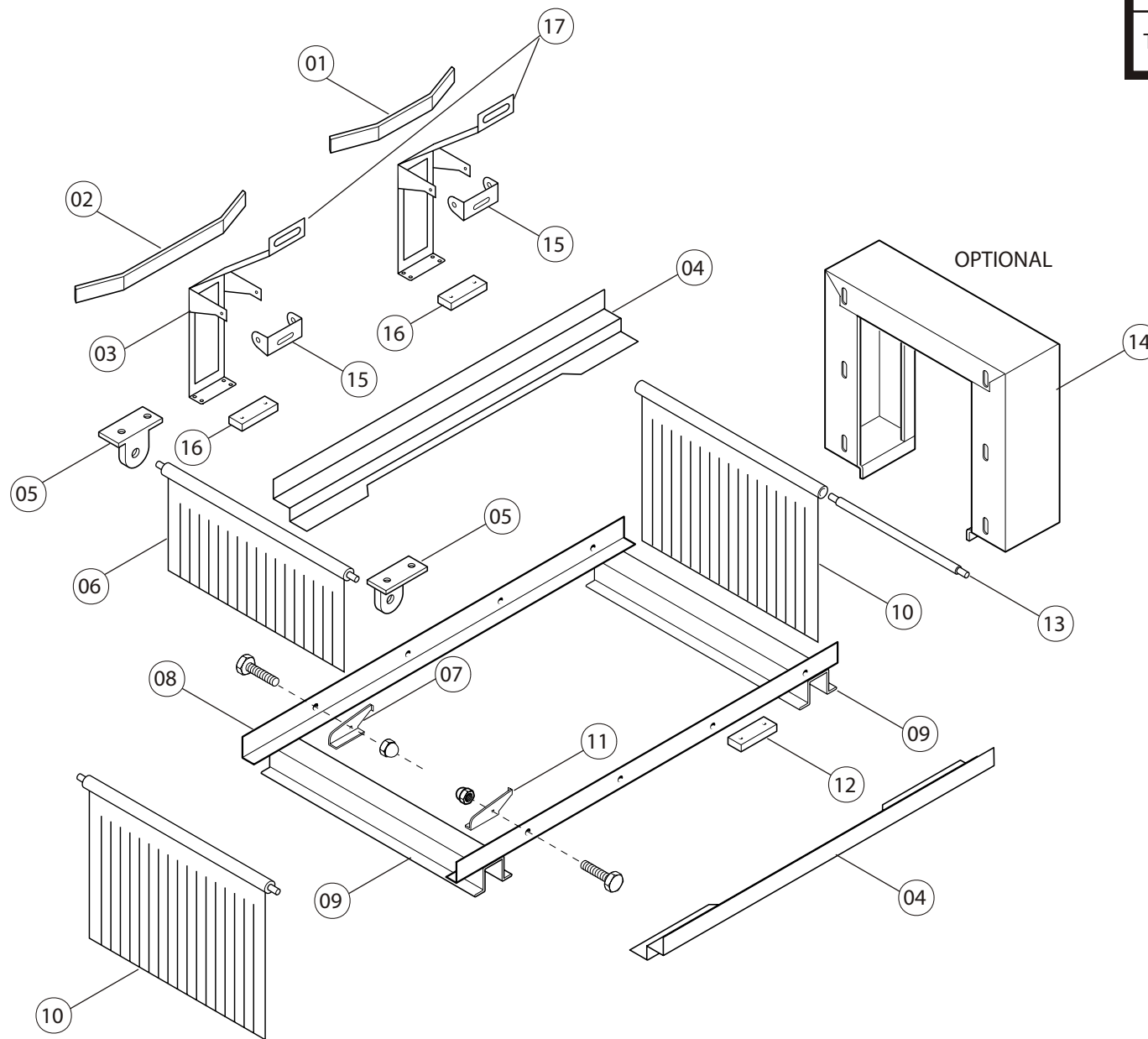

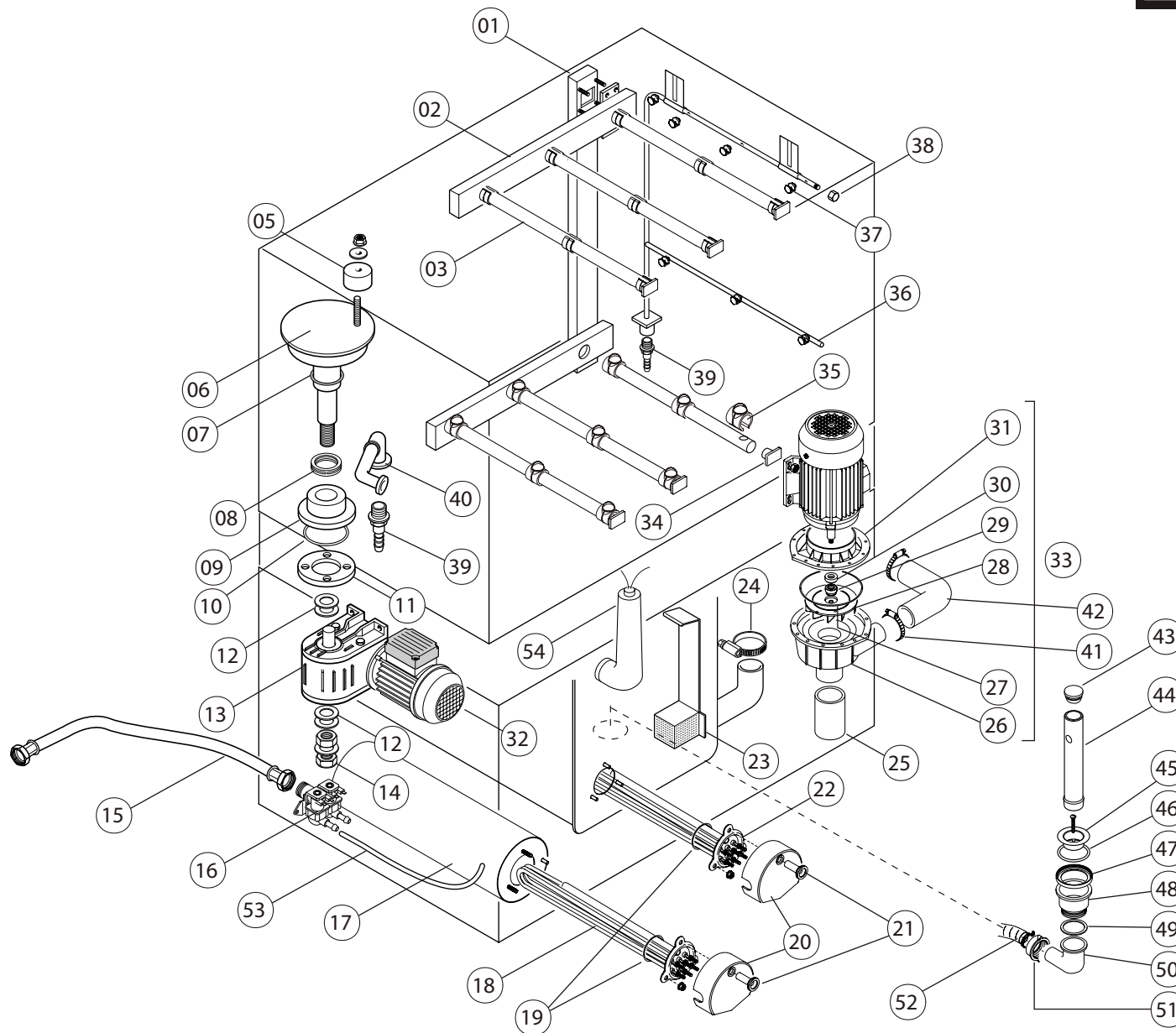



POS.	CODICE MODELLO: ES 50	DESCRIZIONE	DESCRIPTION	DESCRIPTION	BESCHREIBUNG	Q.TY
1	ES50200	Colonna di lavaggio	Wash column	Colonne de lavage	Waschsäule	1
2	ES50210	Collettore inox lavaggio A	Wash stainless steel manifold type A	Collecteur inox lavage A	Sammler aus Edelstahl A	1
3	ES50215	Lancia lavaggio	Complete stainless steel washing pipe	Tuyau lavant inox complet	Spülschlauch aus Edelstahl komplett	6
4	ES50220	Collettore inox B	Wash stainless steel manifold type B	Collecteur inox lavage B	Sammler aus Edelstahl B	1
5	ES50101	Cuscinetto in teflon	Teflon bearing	Douille en Teflon	Lager aus Teflon	1
6	ES50100	Albero motoriduttore	Drive shaft	Arbre de transmission	Antriebswelle	1
7	ES50105	Guarnizione o-ring	Gasket	Joint	Dichtung	1
8	ES50108	Guarnizione viton	Gasket	Joint	Dichtung	1
9	ES50110	Supporto albero motoriduttore	Support drive shaft	Support pour arbre de transmission	Lager aus teflon	1
10	103435	Guarnizione o-ring	Gasket	Joint	Dichtung	1
11	ES50120	Flangia per supporto albero	Drive shaft flange	Bride pour arbre de transmission	Flansch	1
12	ES50122	Molla a tazza	Belleville washer	Ressort à godet	Tellerfeder	6
13	ES50130	Riduttore	Reducer	Réducteur	Untersetzergetriebe	1
14	ES50125	Dado inox	Stainless steel nut	Ecrou inox	Mutter aus rostfreiem Stahl	2
15	1305	Tube carico acqua da 2.0 mt	Water entry pipe, 2.0 m	Tuyau de remplissage eau de 2 m	Wasseransaugschlauch, 2 m lang	1
16	103375	Elettrovalvola doppia	Solenoid valve	Electrovanne	Elektroventil	1
17	ES50420	Boiler inox	Stainless steel boiler	Chauffe-eau inox	Boiler aus Edelstahl	1
18	103432	Resistenza boiler 6000 W	Boiler heater, 6000W	Résistance chauffe-eau 6000W	Heizschlange Boiler 6000W	1
19	103435	Guarnizione or per resist. 4500W	OR heater gasket 4500W	Bague torique résistance 4500W	O-Ring-Dichtung für Heizsch. 4500W	2
20	103460	Protezione resistenza boiler	Boiler heater protection	Protection résistance chauffe-eau	Schutz für Heizschlange Boiler	2
21	103470	Nottolino coperchio resistenza	Heater cover pawl	Cliquet couvercle résistance	Sperrzahn für Deckel von Heizschlange	2
22	103432	Resistenza boiler 6000 W	Boiler heater, 6000W	Résistance chauffe-eau 6000W	Heizschlange Boiler 6000W	1
23	3290	Filtro inox	Stainless steel filter	Filtre inox	Filter aus Edelstahl	1
24	530	Fascetta inox 40-65	Stainless steel band, 40-65	Collier inox 40-65	Schelle aus Edelstahl 40-65	2
25	950700	Manicotto ingresso pompa	Pump entry rubber hose	Manchon entrée pompe	Muffe Pumpeneingang	1
26	7010	Chiocciola motore pompa	Pump motor volute	Vis sans fin moteur pompe	Spiralgehäuse Pumpenmotor	1
27	7012	Guarnizione or per chiocciola pompa	Pump volute OR gasket	Bague torique pour vis sans fin pompe	O-Ring-Dichtung für Spiralgeh. Pumpe	1
28	7011	Girante pompa	Pump rotor	Roue pompe	Lauftrad Pumpe	1
29	6014	Guarnizione tenuta rotante	Rotary sealing gasket	Joint d'étanchéité rotatif	Dichtung Lauftrad	1
30	6013	Guarnizione tenuta ceramica	Ceramic sealing gasket	Joint d'étanchéité céramique	Keramikdichtung	1
31	7013	Flangia motore pompa	Flange wash pump	Bride moteur pompe	Flansch Pumpenmotor	1
32	ES50140	Motore elettrico	Electric motor	Moteur électrique	Elektromotor	1
33	7000	Motore pompa lavaggio	Wash pump motor, 3 HP	Moteur pompe lavage HP 3	Motor Spülpumpe 3 PS	1
34	104030	Tappo lavante in plastica	Plastic washing tap	Bouchon lavant en plastique	Spüldeckel aus Plastik	6
35	104020	Getto lavante in plastica	Plastic washing spout	Jet lavant en plastique	Spüldüse aus Plastik	18
36	ES50230	Colonna di risciacquo	Rinse column	Colonne de rinçage	säule	1
37	104000	Getto di risciacquo in ottone	Brass rinsing spout	Jet de rinçage en laiton	Nachspüldüse aus Messing	6
38	104010	Tappo tubo risciacquo passo 12x1	Rinsing pipe tap, step 12x1	Bouchon tuyau rinçage pas 12x1	Deckel Nachspülschlauch Größe 12x1	2
39	104350	Portagomma ottone 3/8 M	Brass joint holder, 3/8 M	Porte tuyau en laiton 3/8 M	Schlauchhalterung aus Messing 3/8 Zoll mit Innengewinde	1
40	ES50240	Tube riempimento vasca	Tank filling pipe	Tube de remplissage cuve	Rohr für Wannenfüllung	1
41	560	Fascetta inox 59-63	Stainless steel band, 59-63	Collier inox 59-63	Schelle aus Edelstahl 59-63	2

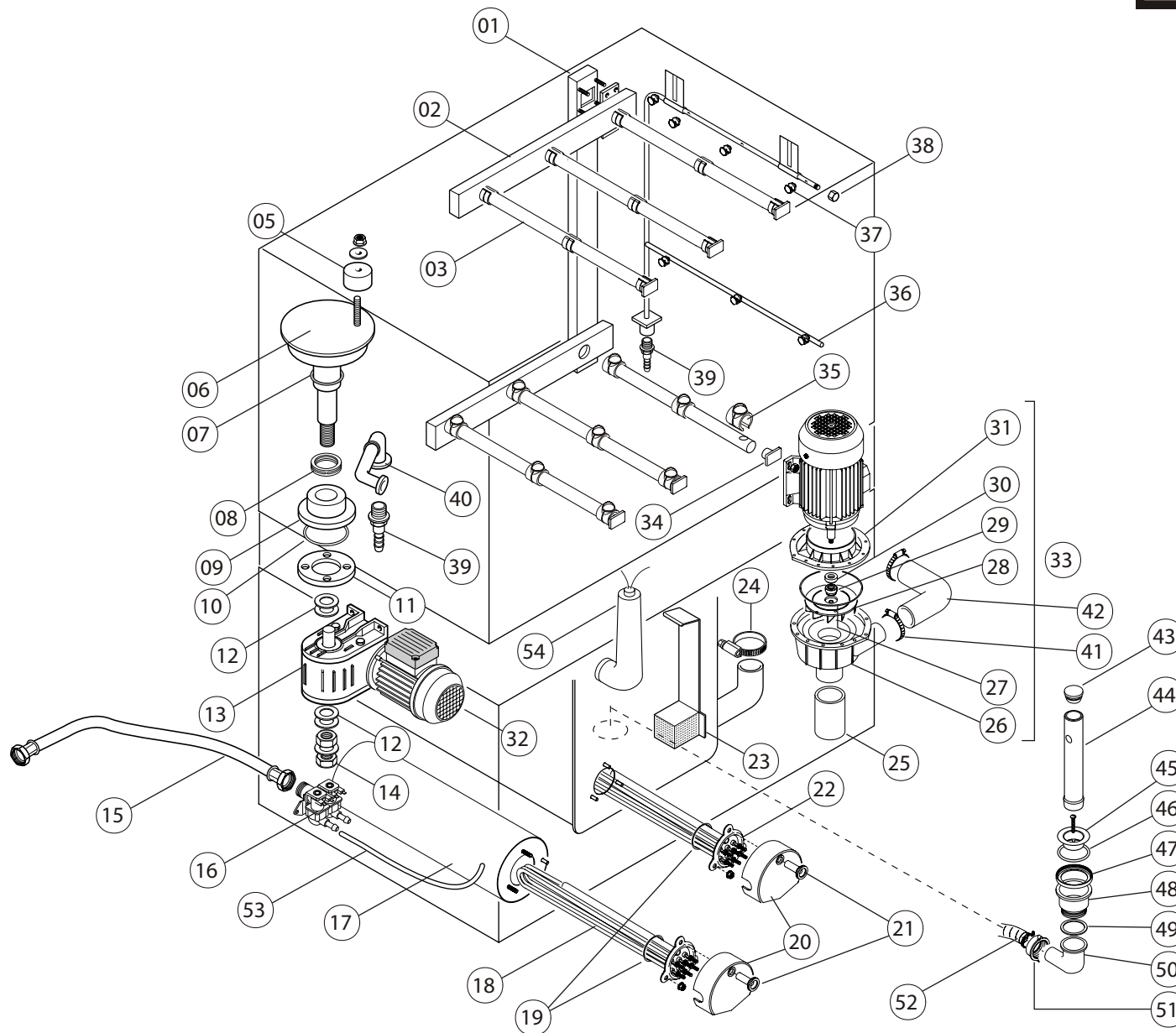

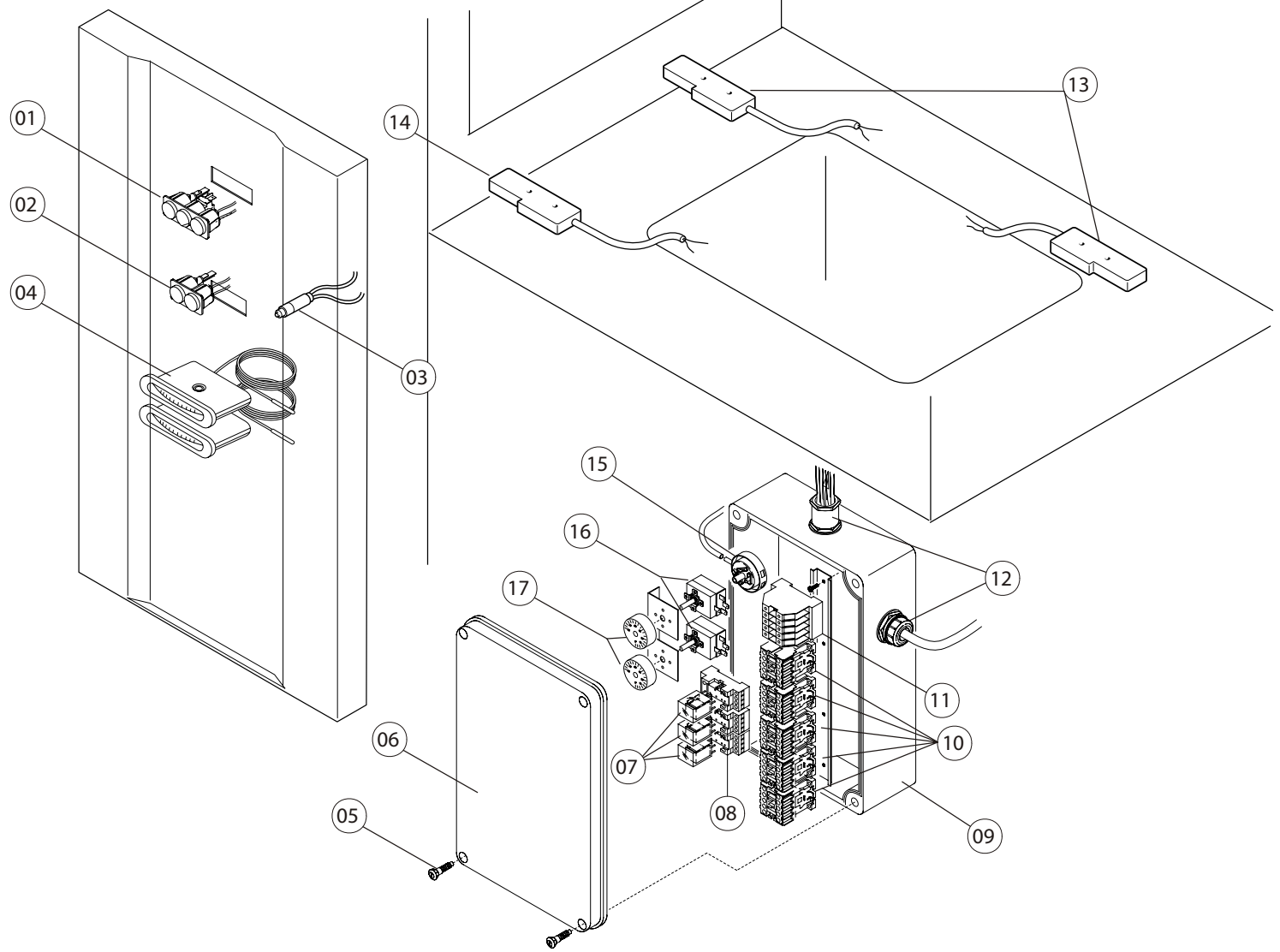

ES 50

TAV.57

CESTELLI

