

# HOOD TYPE MACHINE

INSULATED DOUBLE WALLED CAPOTE  
ELECTROMECHANICAL SWITCHES

TYPE: 14U

Accessories  
BREAK TANK  
BOOSTER PUMP  
DVGW  
WATER SOFTNER  
DETERGENT DISPENSER  
DRAIN PUMP

---

## Spare parts manual

---

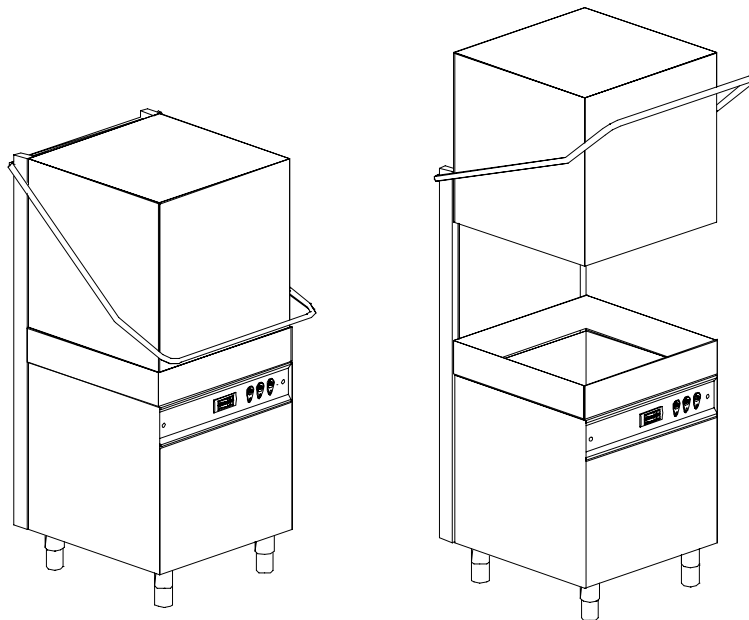



## 1. Spare parts

General body parts.....	7
Closing panelig.....	9
Capote insulation.....	11
Control electric components.....	13
Control electric components.....	15
Solenoid valve group .....	17
Solenoid valve group .....	19
Break Tank .....	21
Booster pump.....	23
DVGW .....	25
Water softner group.....	27
Shining product dosing device group .	29
Shining product dosing device group .	31
Boiler group .....	33
Derivation group .....	37
Wash pump group.....	39

---

<b>Dosing device group .....</b>	<b>41</b>
<b>Dosing device group .....</b>	<b>43</b>
<b>Drain pump group.....</b>	<b>45</b>
<b>Pressure switch group with air trap ...</b>	<b>47</b>
<b>Turret group with rotating arms .....</b>	<b>49</b>

## 1.1 Voltage codes

Voltage code	Voltage
A	3/N/PE~400/230V 50Hz
B	~250V 16A 50Hz
C	3/N/PE~380/220V 50Hz
D	3/PE~200V 50-60Hz
F	2/PE 220-240V 50Hz
G	3/N/PE~415/240V 50Hz
H	3/PE~230V 50Hz
I	3/PE~220V 60Hz
J	3/PE~380 50Hz
K	3/PE~400V 50Hz
L	3/PE~415V 50Hz
M	3/PE~440V 60Hz
N	3/PE~460V 60Hz
O	3/PE~480V 60Hz
P	1/N/PE~220-240V 50Hz
R	2/PE~220-230V 60Hz
S	3/N/PE~400/230V 50Hz
T	3/PE~230V 60Hz

## 1.2 Product codes

Product code	Full name
Model codes	
is	INSULATED DOUBLE WALLED CAPOTE
em	ELECTROMECHANICAL SWITCHES
Type codes	
14U	14U
Accessory codes	
bt	BREAK TANK
pap	BOOSTER PUMP
dvgw	DVGW
d	WATER SOFTNER
dde	DETERGENT DISPENCER
ps	DRAIN PUMP

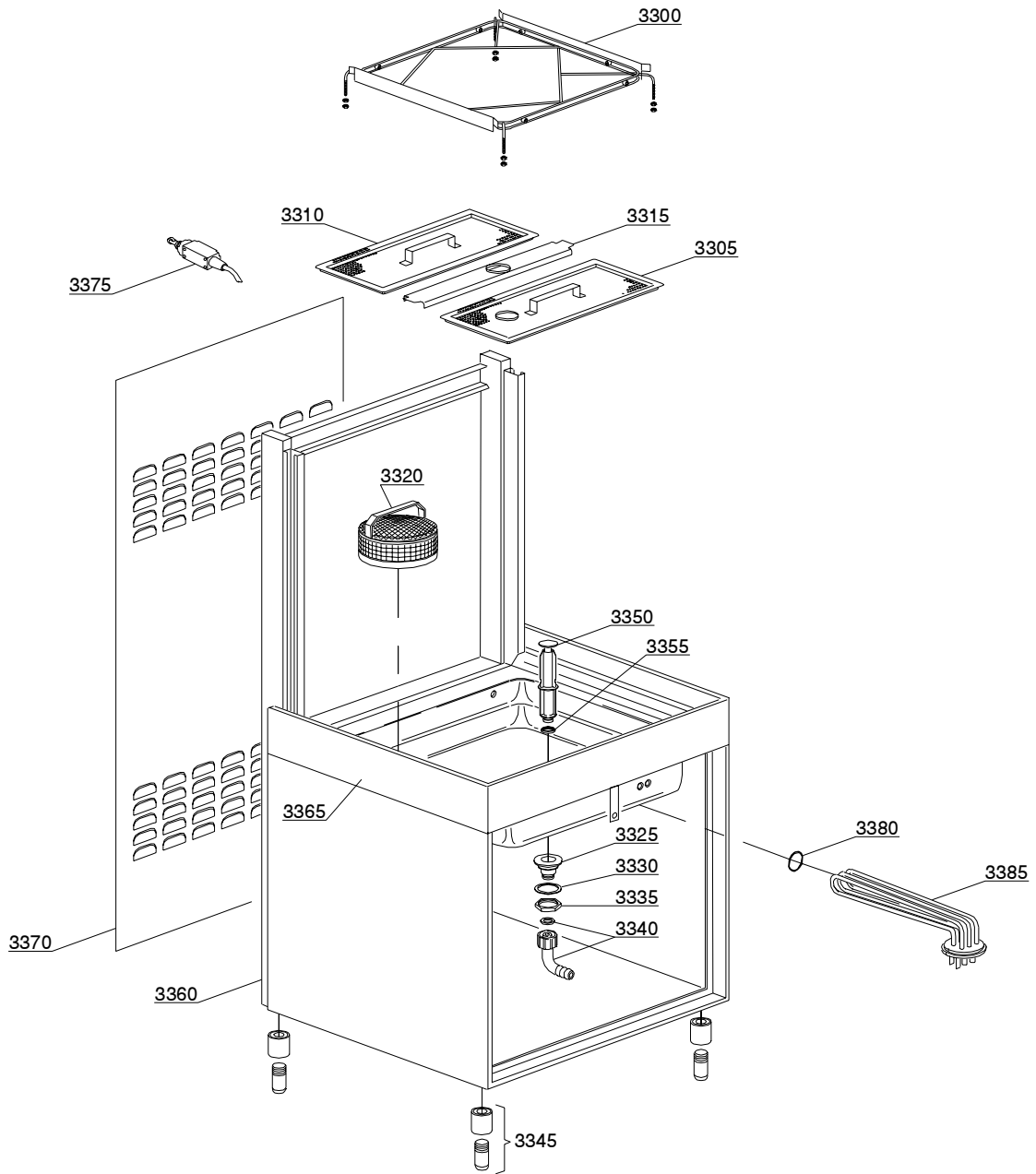

01\_003\_e

## Spare parts

ID	P-code	Model	Type	Accessory	Voltage	Description
MODULE:General body parts						
3300	10600918		14U			Basket support
3305	75625		14U			Half-filter with hole
3310	75626		14U			Surface half-filter
3315	75926		14U			Sleeper holder-filter
3320	15911		14U			Stainless steel filter
3325	10200113		14U			Floor drain
3325	15063		14U			Stainless steel floor drain
3330	10200173		14U			75x58x2 gasket
3335	10200114		14U			Floor drain nut
3340	15613		14U			Drain elbow
3345	15116		14U			Foot
3350	500618		14U			Overflow pipe
3350	75250		14U	dp		Overflow pipe
3355	13021		14U			DEM 40 gasket
3360	75600		14U			Base assembly
3365	75601		14U			Tank/back panel assembly
3370	75305		14U			Back panel
3370	75306		14U	bt		Back panel
3375	70305		14U			Limit stop push button
3380	13015		14U			6225 OR 160 NBR gasket
3385	15047/A		14U			2,7KW heating element

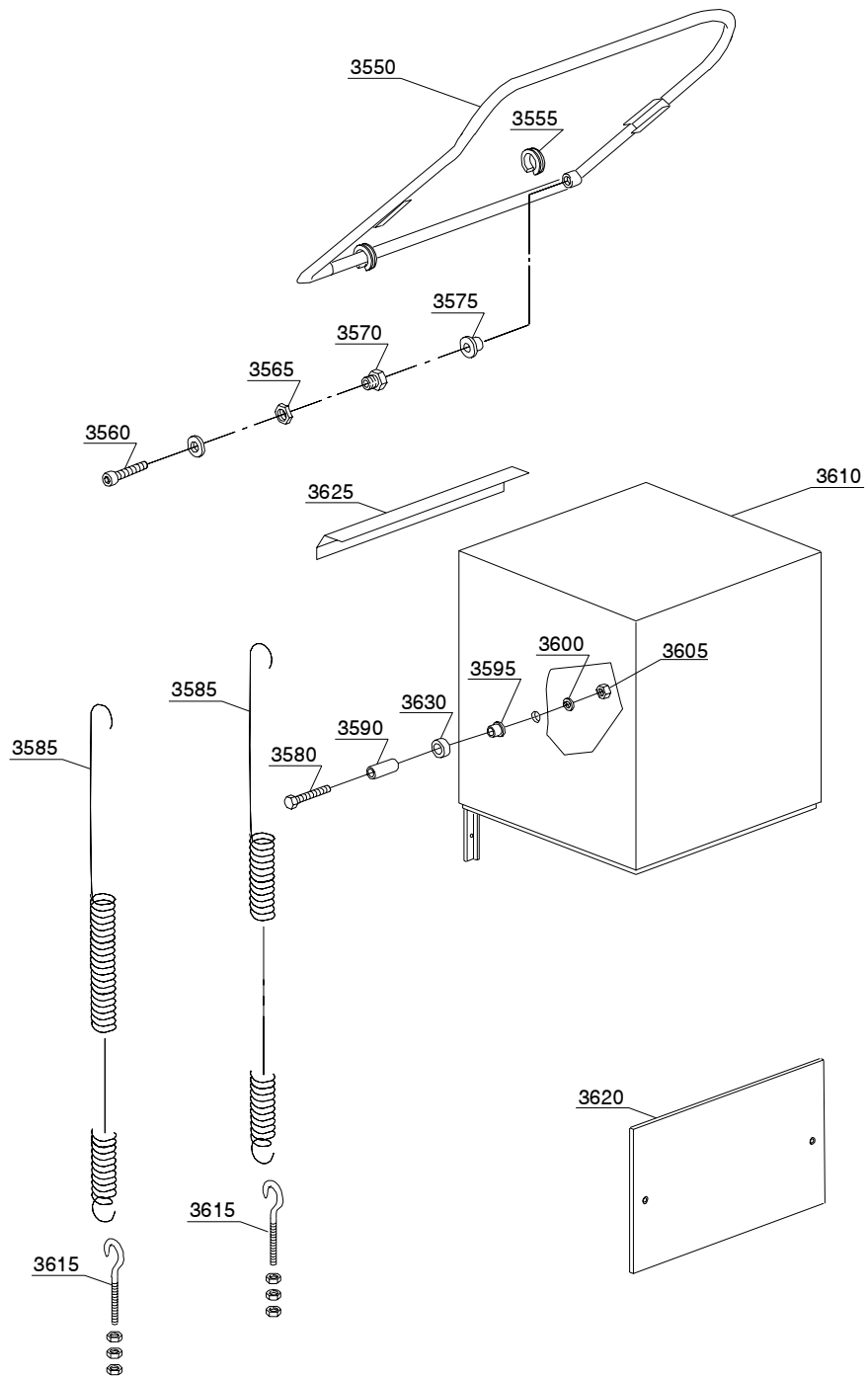

02\_201\_e



## Spare parts

ID	P-code	Model	Type	Accessory	Voltage	Description
MODULE:Closing panelig						
3550	75301		14U			Grip
3550	75302		14U			Grip
3555	70306		14U			Spring hook joint
3560	75201		14U			Stainless steel bolt
3565	75202		14U			Brass nut
3570	75203		14U			Brass bush
3575	75204		14U			Teflon bush
3580	10800129		14U			Pin
3580	10800128		14U			Wheel door fixing pin
3585	75303		14U			Back spring
3590	10800130		14U			Pin spacer
3595	10800231		14U			Roller bush
3600	10600206		14U			Ogive
3605	11718		14U			M8 stainless steel self-locking nut
3610	75900		14U			Capote
3615	10800210		14U			Tie rod screw with hook
3620	75605		14U			Lower door
3625	75615		14U			Back sleeper
3630	10800244		14U			Door roller

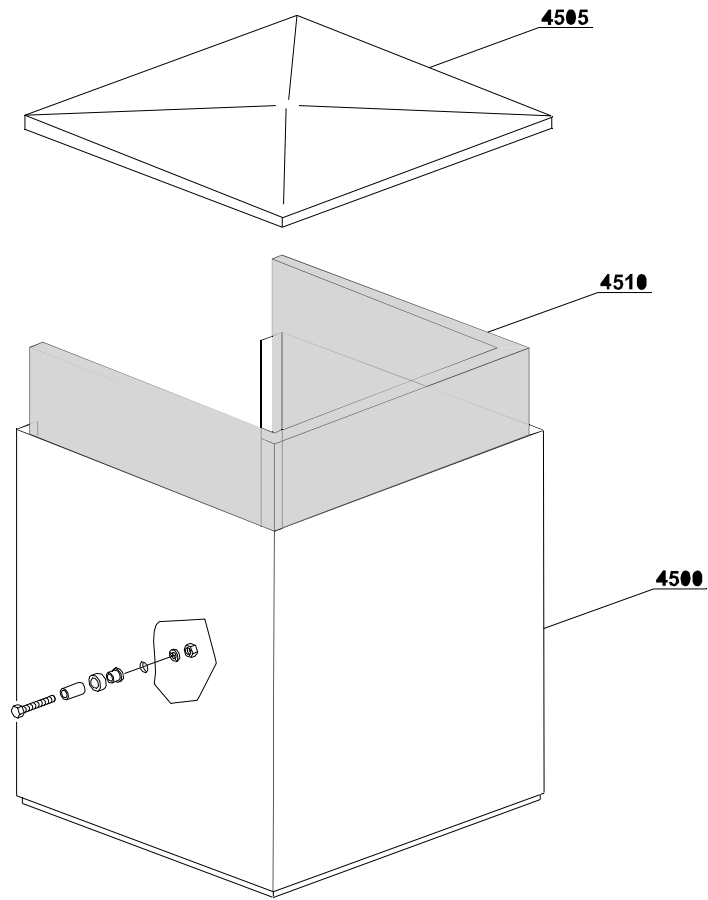

02\_300\_e

## Spare parts

---

ID	P-code	Model	Type	Accessory	Voltage	Description
MODULE:Capote insulation						
4500	75901		14U			Counter-capote
4505	75902		14U			Capote cover
4510	75210		14U			Complet insulation

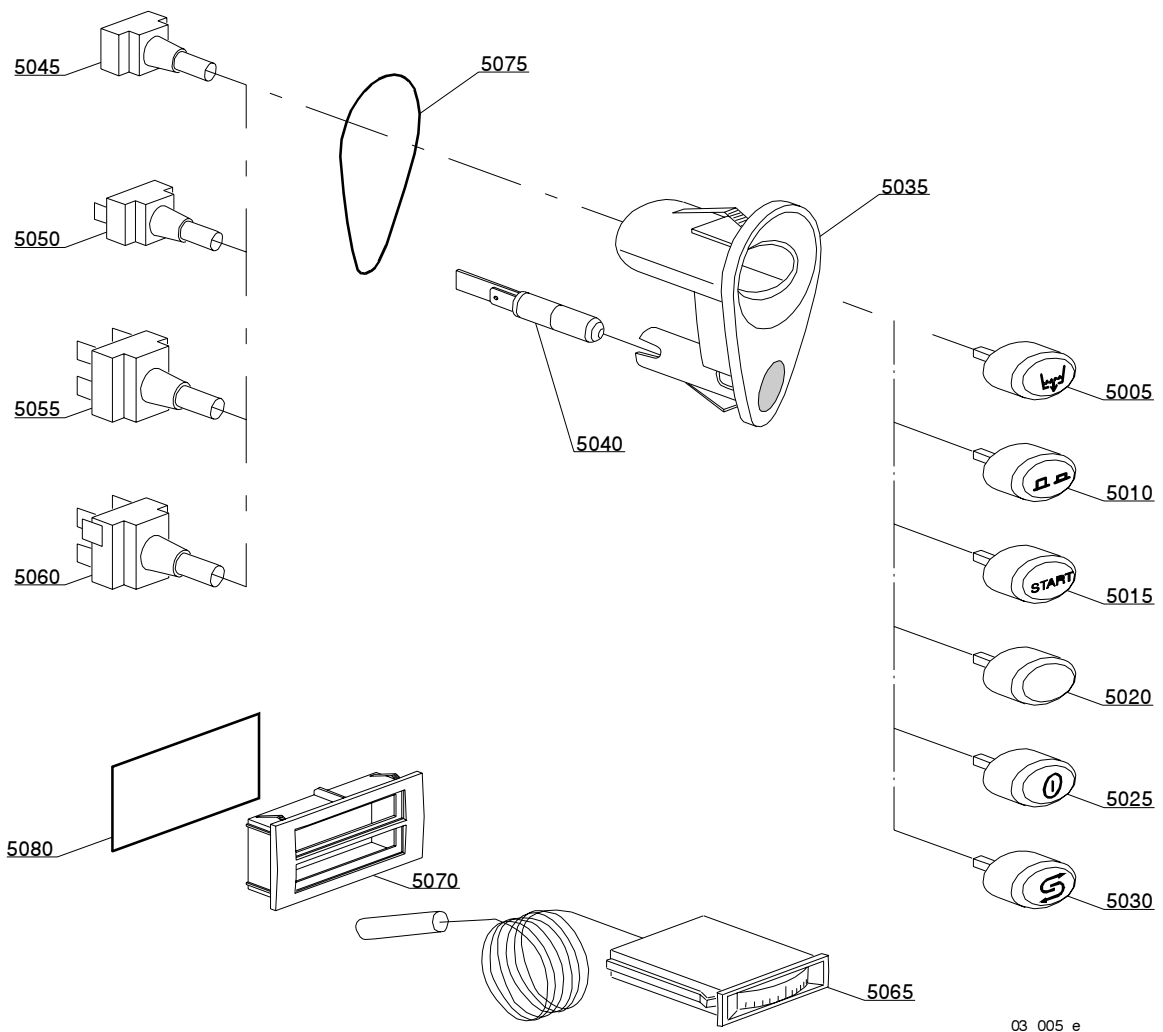
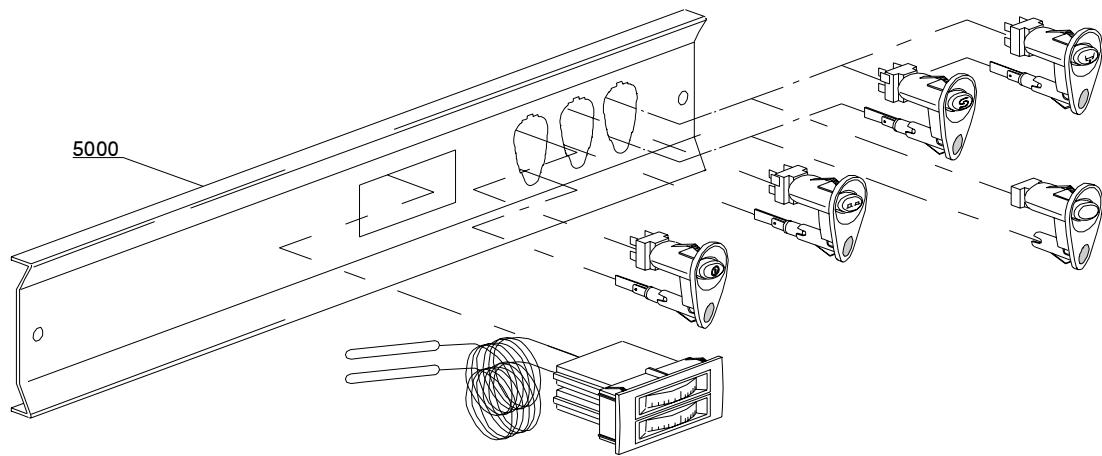



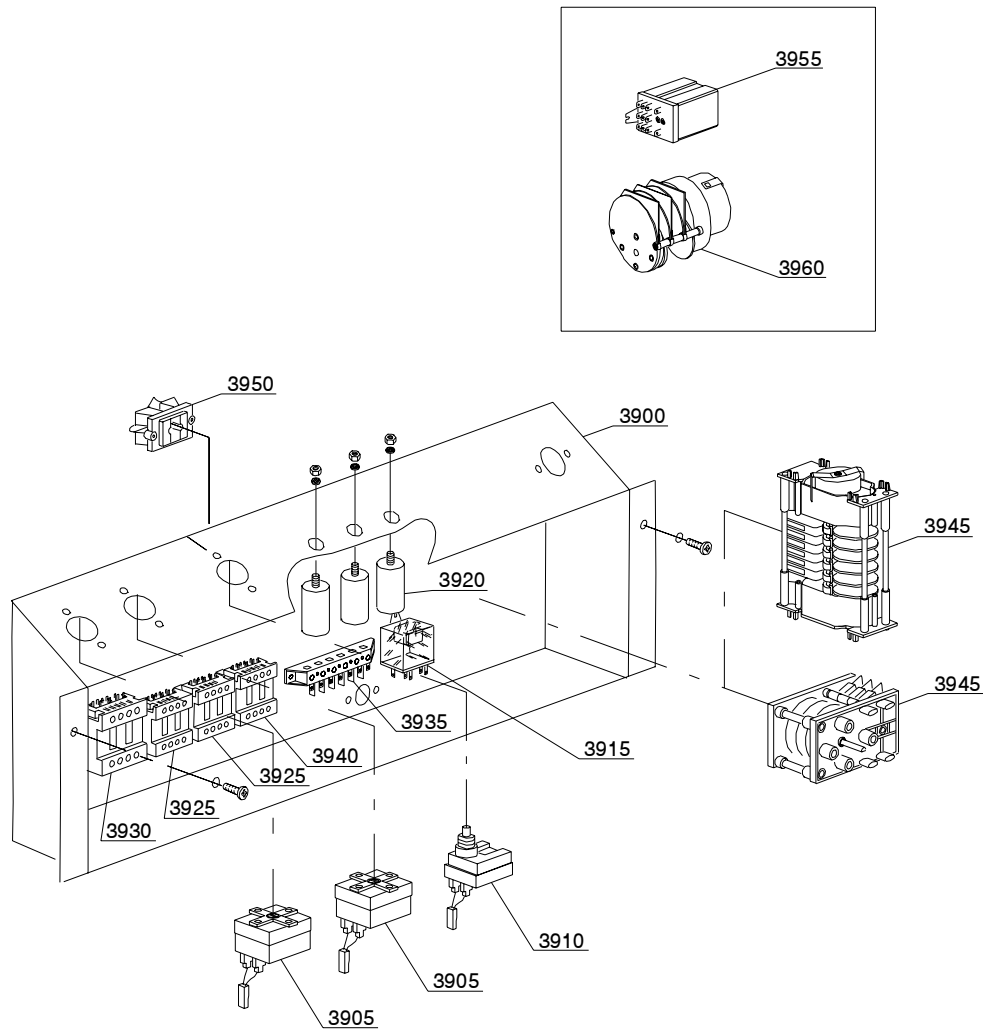

04\_002\_e



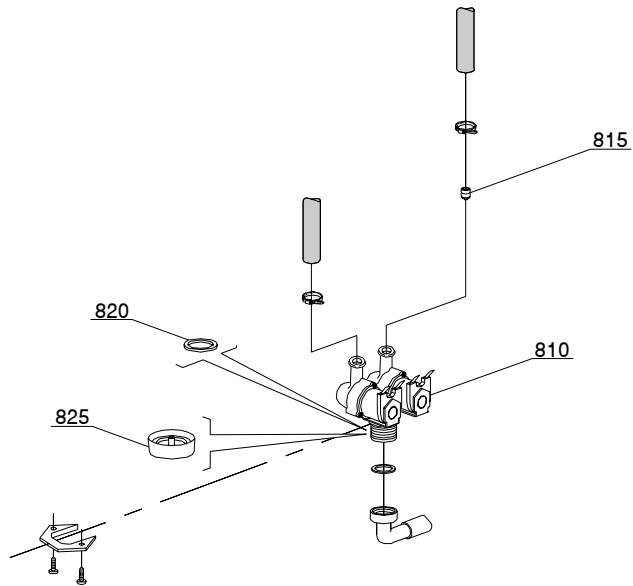

05\_003\_e



## Spare parts

---

ID	P-code	Model	Type	Accessory	Voltage	Description
MODULE:Solenoid valve group						
810	15098		14U	cr,ws		Double solenoid valve - Ø10
815	15115		14U	cr,ws		Green pression solenoid valve
820	N.C.		14U	cr,ws		Pression reducing valve

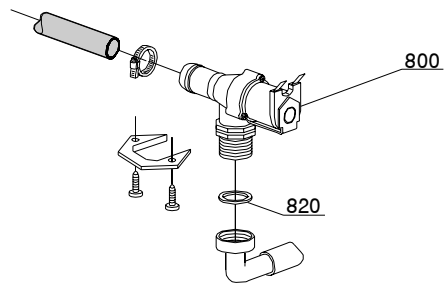

05\_005\_e

## Spare parts

---

ID	P-code	Model	Type	Accessory	Voltage	Description
MODULE:Solenoid valve group						
800	30001000		14U			Single solenoid valve
820	N.C.		14U			Pression reducing valve

06\_001\_e

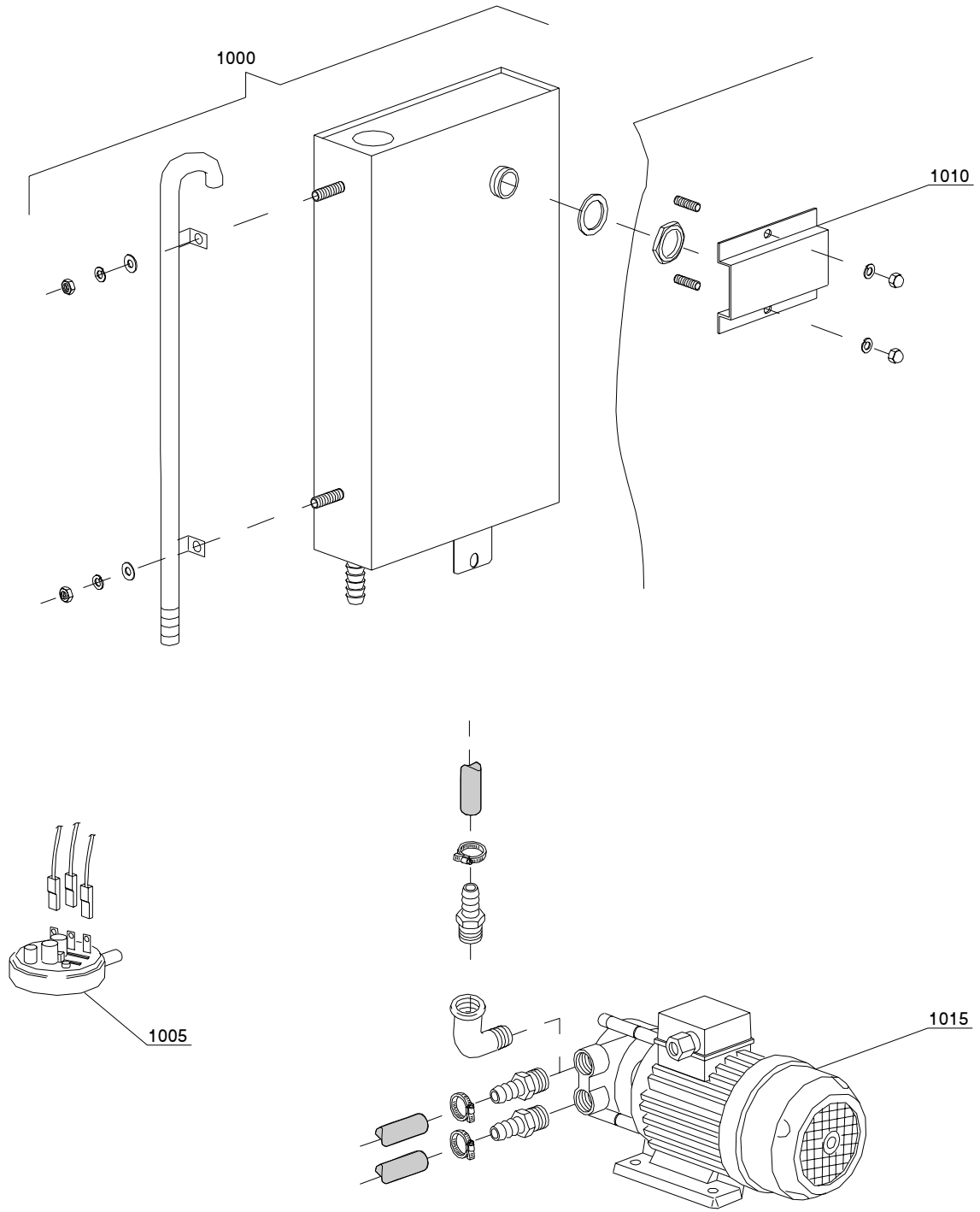

## Spare parts

---

ID	P-code	Model	Type	Accessory	Voltage	Description
MODULE:Break Tank						
1000	15735		14U	bt		Break tank assembly
1005	10706/A		14U	bt		47-27 pressure switch
1010	15738		14U	bt		Hole protection
1015	15100		14U	bt		Booster pump

07\_002\_e

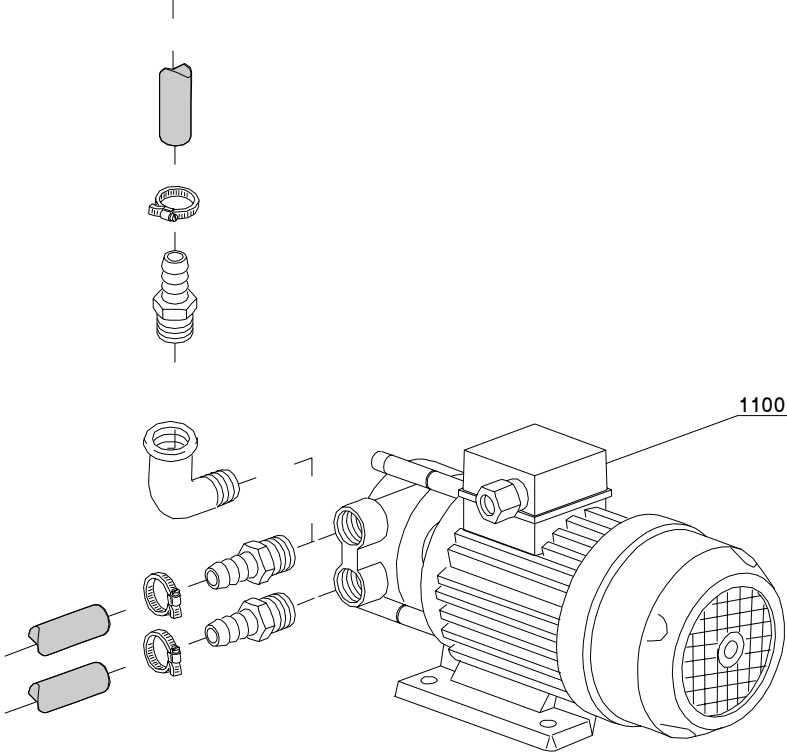

**Spare parts**

---

ID	P-code	Model	Type	Accessory	Voltage	Description
MODULE:Booster pump						
1100	15100		14U	bp		Booster pump

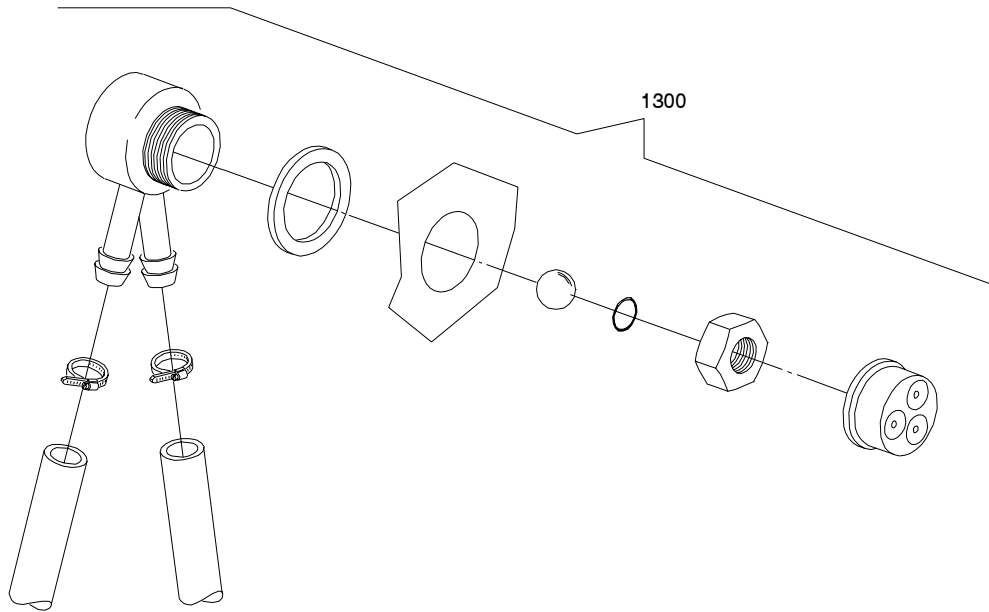

08\_005\_e



**Spare parts**

---

ID	P-code	Model	Type	Accessory	Voltage	Description
MODULE: DVGW						
1300	999900006		14U	dvgw		DVGW assembly

09\_001\_e

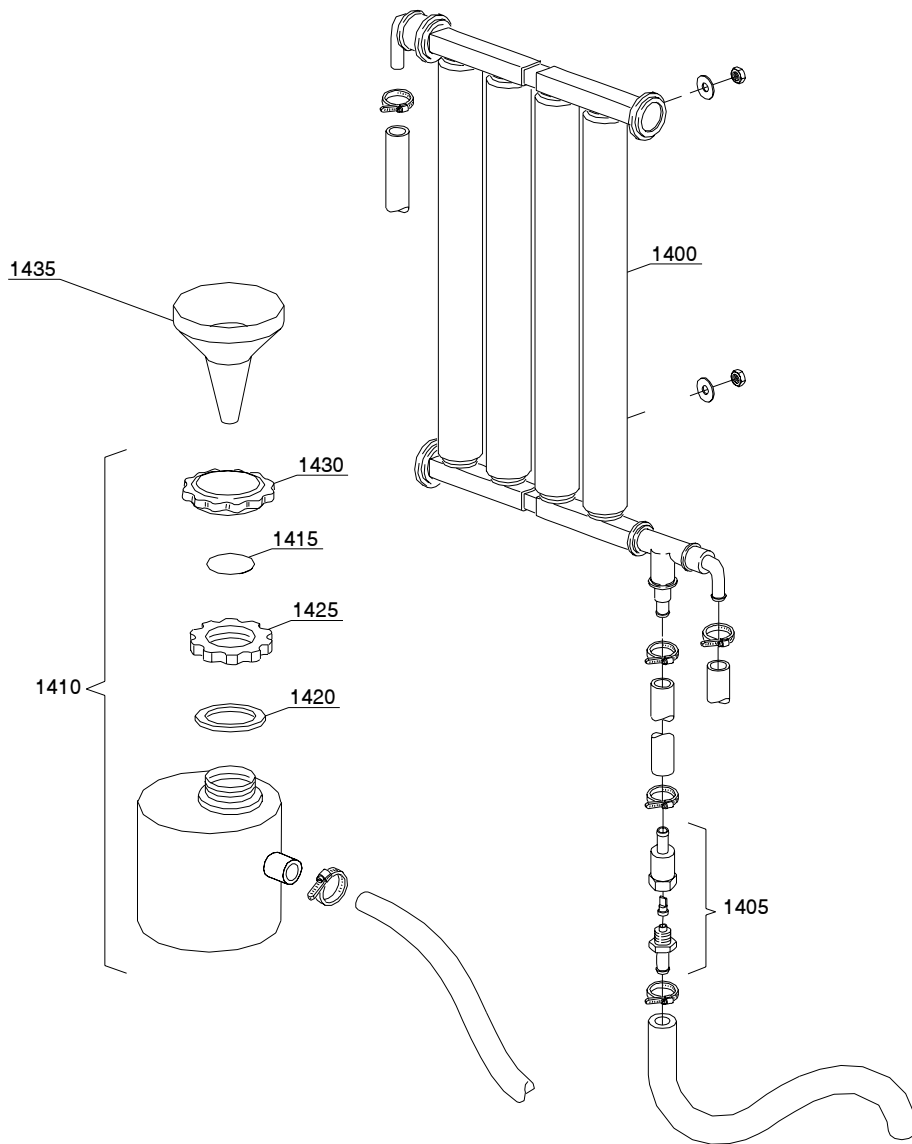

## Spare parts

ID	P-code	Model	Type	Accessory	Voltage	Description
MODULE:Water softner group						
1400	16066		14U	ws		4 elements water softner
1405	16070		14U	ws		Nonreturn valve
1410	16065		14U	ws		Salt container
1415	16067/A		14U	ws		OR gasket
1420	16067/B		14U	ws		Gasket
1425	16067/C		14U	ws		Ring nut
1430	16067/D		14U	ws		Plug
1435	16082		14U	ws		Funnel

10\_002\_e

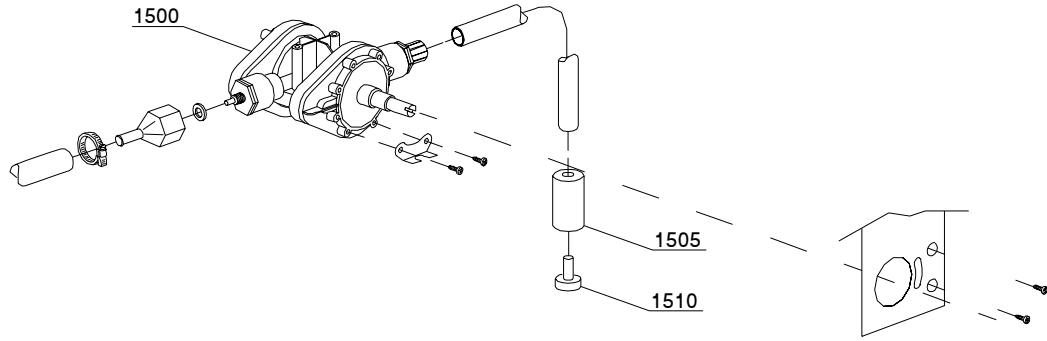

**Spare parts**

ID	P-code	Model	Type	Accessory	Voltage	Description
MODULE:Shining product dosing device group						
1500	10798		14U			Shining product dosing device
1505	12525		14U			Counter-weight
1510	15058		14U			Small filter
1515	10798/B		14U			Brass pipe fitting

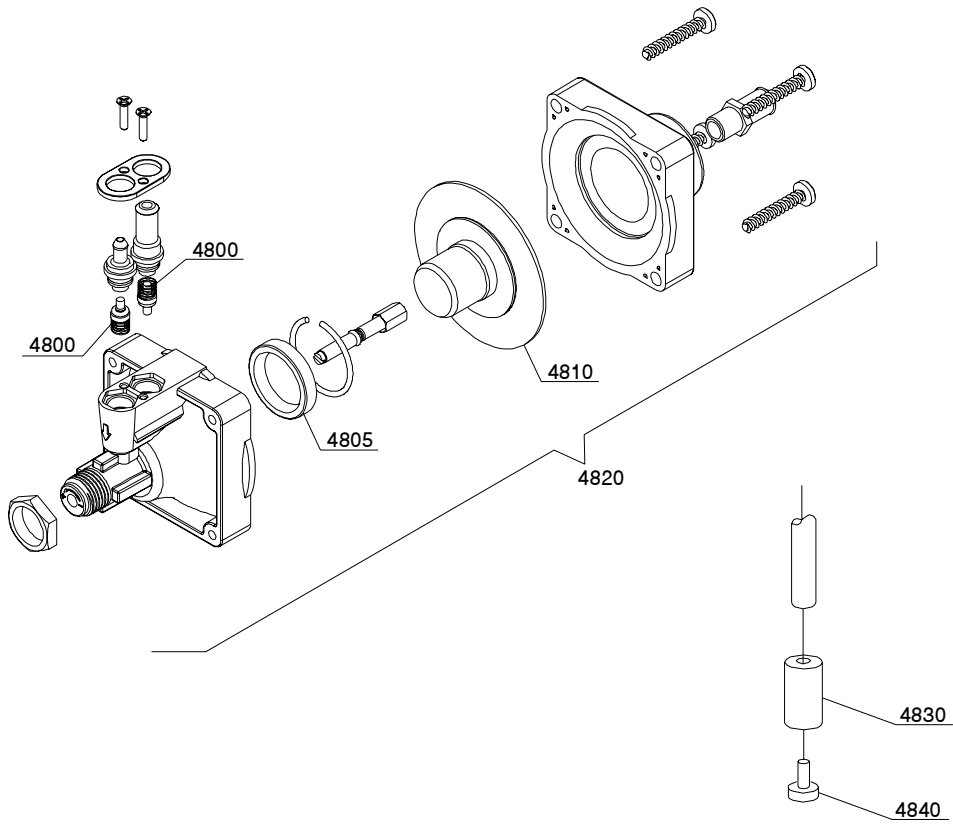

10\_004\_e

## Spare parts

ID	P-code	Model	Type	Accessory	Voltage	Description
MODULE:Shining product dosing device group						
4800	10805		14U			Tecno pro dosing valve
4805	10806		14U			Ø22 gasket
4810	10807		14U			Membrane
4820	10799		14U			Shining product dosing device
4830	12525		14U			Counter-weight
4840	15058		14U			Small filter

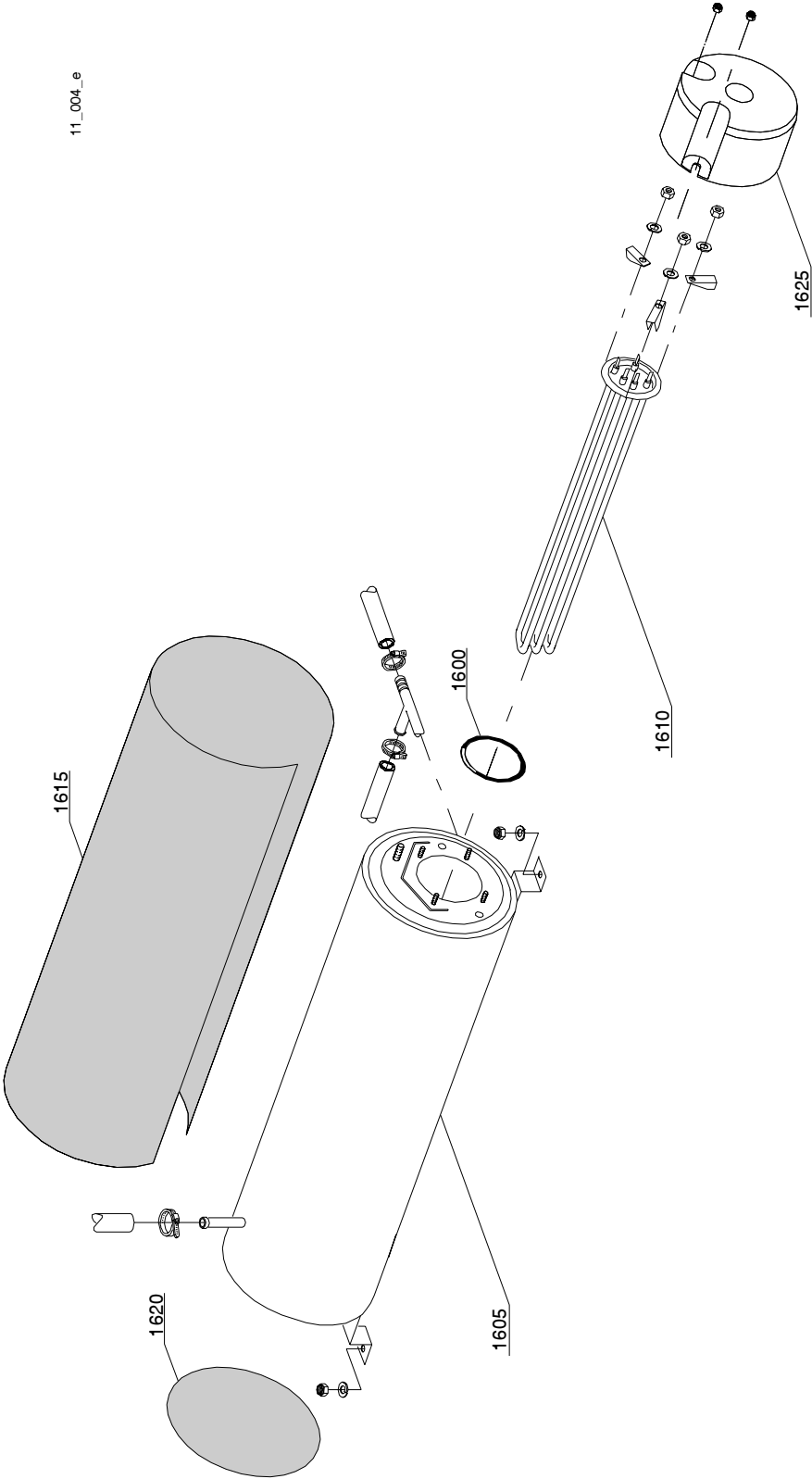



## Spare parts

ID	P-code	Model	Type	Accessory	Voltage	Description
MODULE:Boiler group						
1600	13015		14U			6225 OR 160 NBR gasket
1605	22002		14U			Boiler
1610	30001010		14U			6KW heating element
1610	30001011		14U			9KW heating element
1610	30001011/A		14U			12KW heating element
1615	30002030		14U			Insulating boiler
1620	75205		14U			Ø160 bottom
1625	75311		14U			Heating element guard

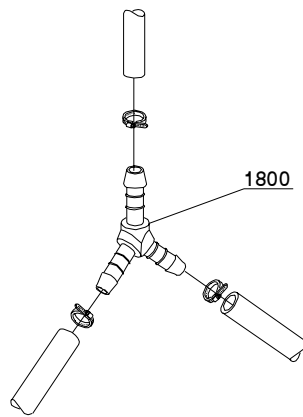

12\_003\_e

**Spare parts**

---

ID	P-code	Model	Type	Accessory	Voltage	Description
1800	540090		14U	ws		Ø10 mm plastic 3 ways derivation

12\_007\_e

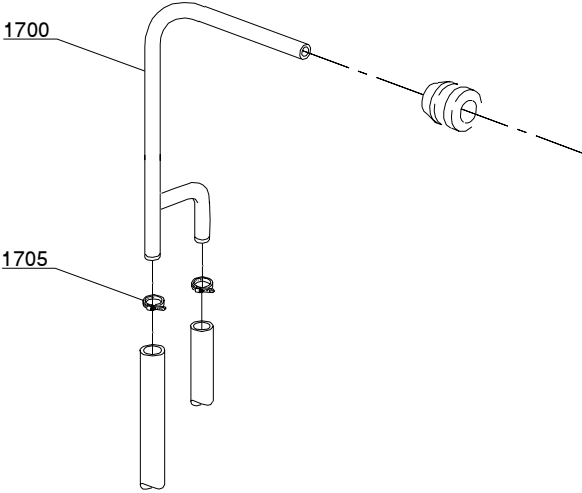

## Spare parts

---

ID	P-code	Model	Type	Accessory	Voltage	Description
MODULE:Derivation group						
1700	15045/B		14U			3 ways derivation
1705	11807		14U			12/22 clamp

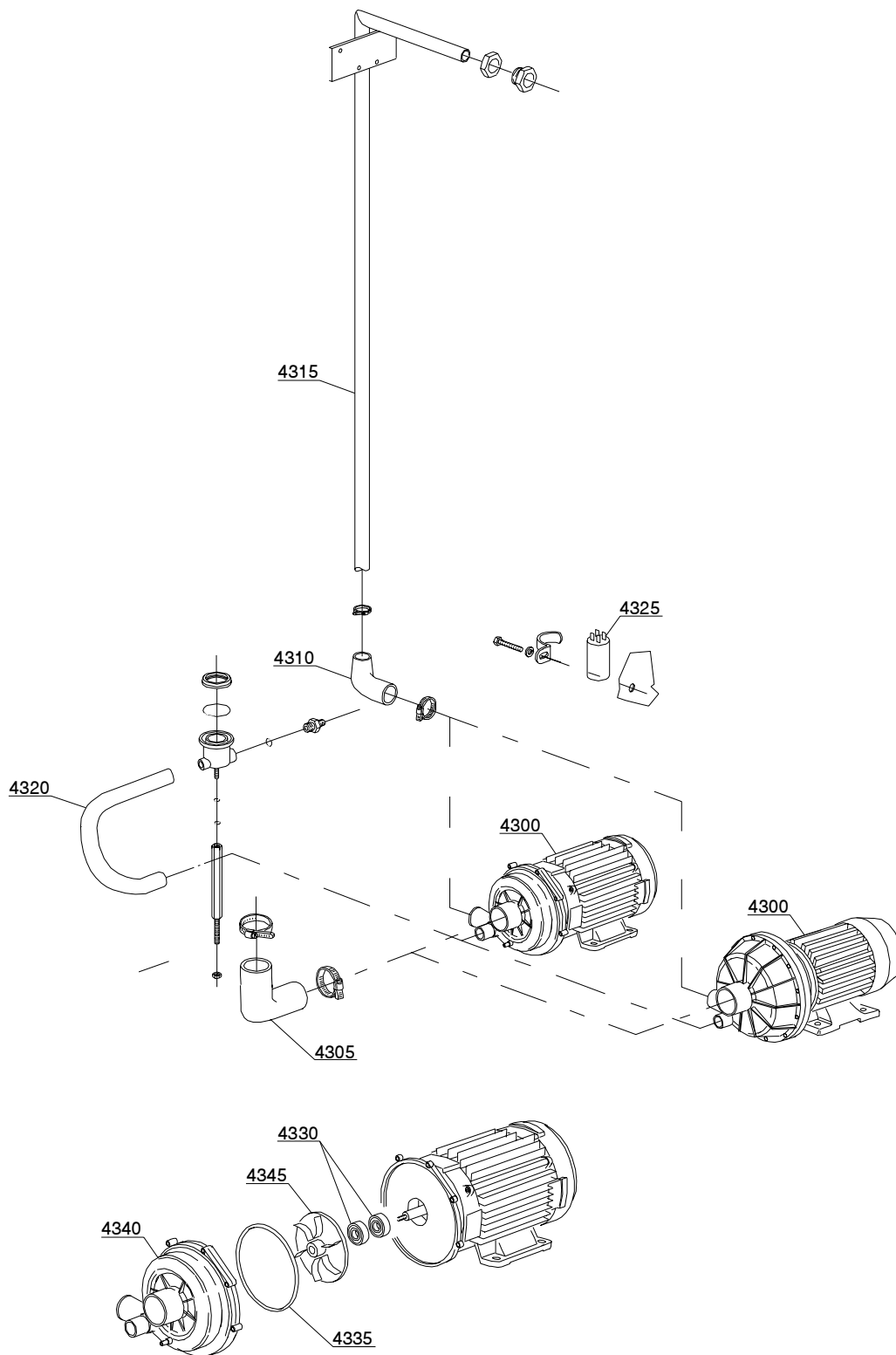

13\_103\_e

## Spare parts

ID	P-code	Model	Type	Accessory	Voltage	Description
MODULE:Wash pump group						
4300	22009		14U		A	1,5Hp pump
4300	22036		14U		I	1,5Hp - 60Hz pump
4305	15032/A		14U			Suction pipe coupling
4310	16170/M		14U			Delivery side pipe coupling
4315	75003		14U			Wash ramp
4320	15033/A		14U			Lower delivery wash pipe
4325	15081/A		14U			Condenser 16 uF
4330	15080/E		14U			Rotating seals
4335	15080/A		14U			OR gasket
4340	15078		14U			Scroll
4345	22009/A		14U			Pump rotor

14\_002\_e

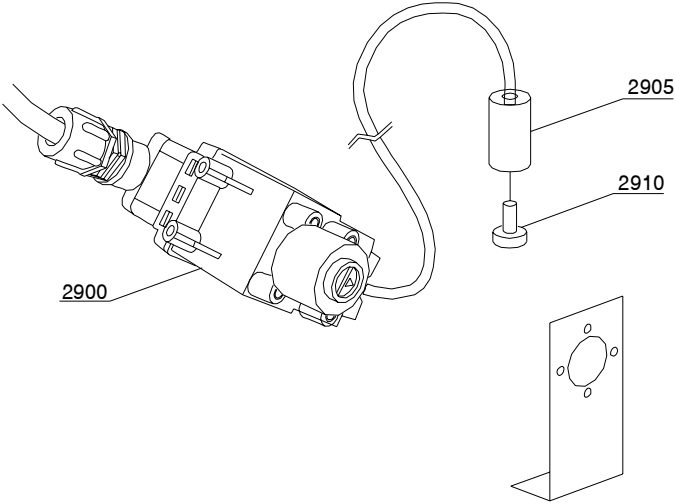
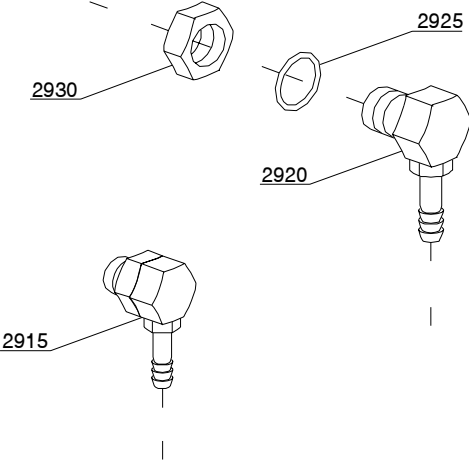



## Spare parts

ID	P-code	Model	Type	Accessory	Voltage	Description
MODULE:Dosing device group						
2900	15108/L		14U	dd		Lang dosing device
2905	12525		14U	dd		Counter-weight
2910	15058		14U	dd		Small filter
2915	15123		14U	dd		Compleat plastic injector
2920	15148		14U	dd		Steel injector
2925	15159		14U	dd		OR gasket
2930	1020020 5		14U	dd		M12x1 stainless steel nut

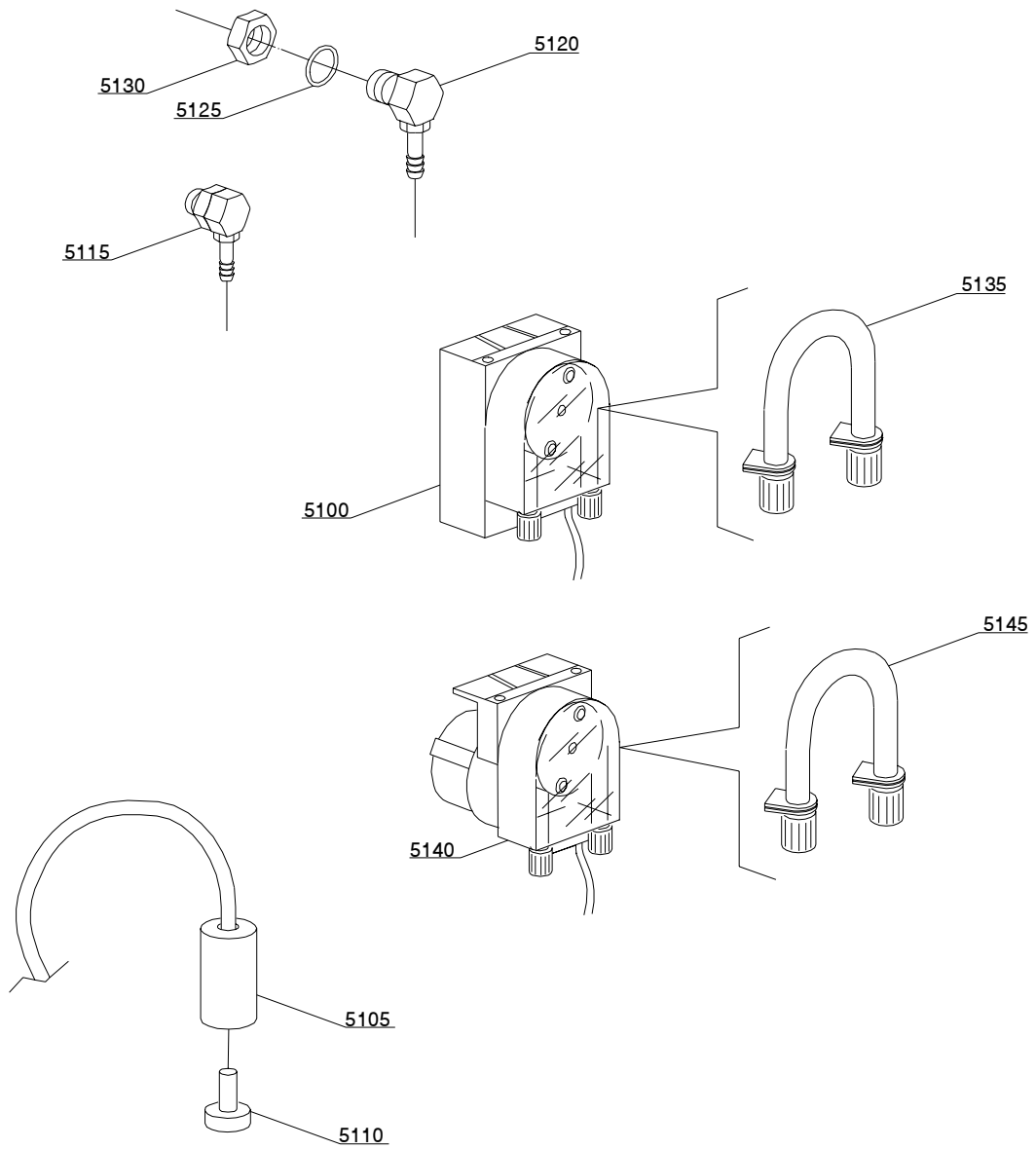

14\_004\_e

## Spare parts

ID	P-code	Model	Type	Accessory	Voltage	Description
MODULE:Dosing device group						
5100	15985		14U	dd		Seko dosing device
5105	12525		14U	dd		Counter-weight
5110	15058		14U	dd		Small filter
5115	15123		14U	dd		Complet plastic injector
5120	15148		14U	dd		Steel injector
5125	15159		14U	dd		OR gasket
5130	10200205		14U	dd		M12x1 stainless steel nut
5135	15185		14U	dd		Seko thermoplastic pipe
5140	15985		14U	dd		Germac dosing device
5145	15108/E		14U	dd		Germac thermoplastic pipe

15\_003\_e

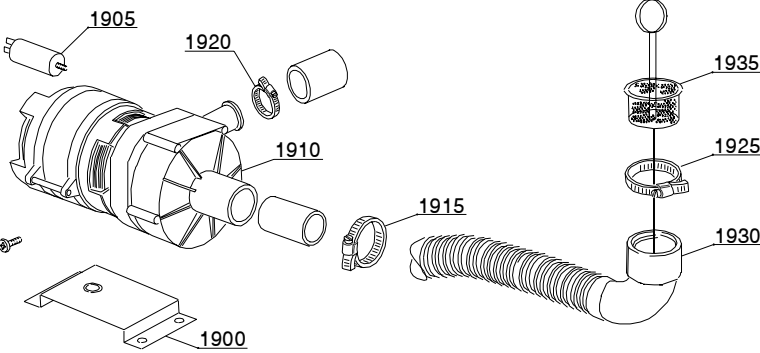

## Spare parts

ID	P-code	Model	Type	Accessory	Voltage	Description
MODULE:Drain pump group						
1900	440122		14U	dp		Pump support
1905	10702		14U	dp		5 uF condenser
1910	10501/A		14U	dp		Drain pump
1910	10501/D		14U	dp		Drain pump
1915	11806		14U	dp		25/40 clamp
1920	11836		14U	dp		20/32 clamp
1925	11809		14U	dp		30/45 clamp
1930	15131		14U	dp		Suction pipe
1935	10200039		14U	dp		Flow drain filter
1945	11600050		14U	dp		Suction pipe

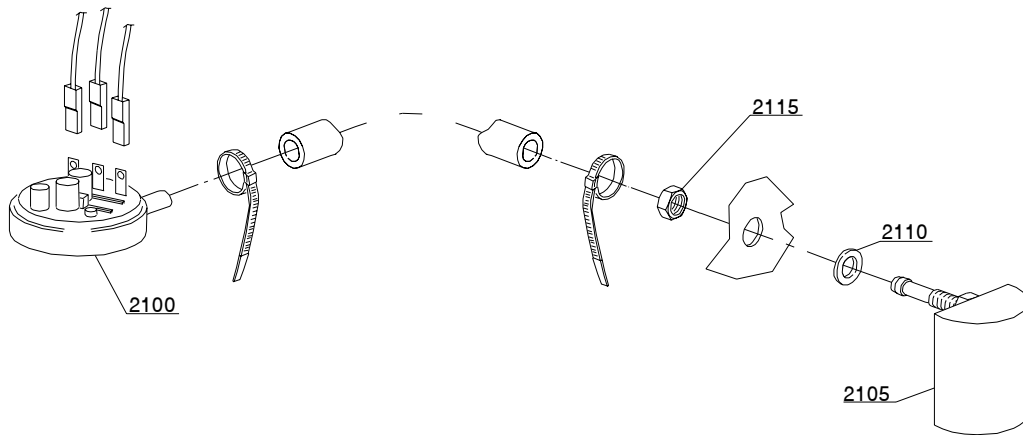

16\_001\_e

## Spare parts

---

ID	P-code	Model	Type	Accessory	Voltage	Description
MODULE:Pressure switch group with air trap						
2100	75950		14U			86-59 pressure switch
2105	10911/C		14U			Air trap assembly
2110	13301		14U			Gasket
2115	11702		14U			M8 stainless steel nut

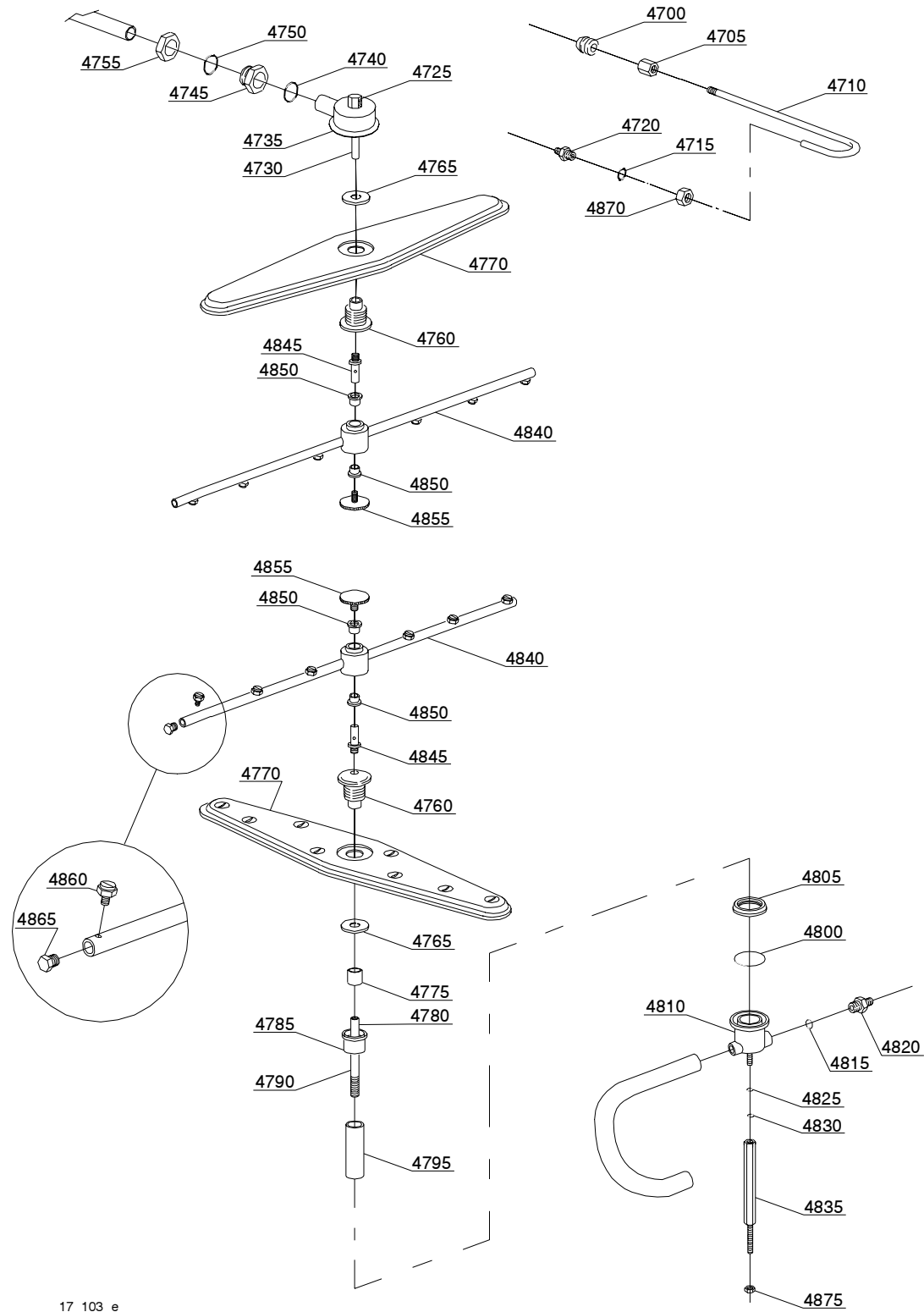

17\_103\_e



## Spare parts

ID	P-code	Model	Type	Accessory	Voltage	Description
MODULE:Turret group with rotating arms						
4700	13304		14U			Pipe-pass gasket
4705	12526		14U			Stainless steel pipe coupling
4710	75066		14U			Top rinse ramp
4715	13003		14U			OR 112 NBR gasket
4720	12006		14U			Ø10 rinse pipe fitting
4725	75319		14U			Rinse elbow
4730	75322		14U			Top rinse axle extension
4735	75067		14U			Stainless steel turret
4740	13004		14U			OR 3137 NBR gasket
4745	15042		14U			"1" 1/4 ring nut"
4750	13008		14U			OR 147 NBR gasket
4755	15042/A		14U			Nut
4760	75320		14U			Hub for rotor
4765	75317		14U			Nut for hub
4770	75915		14U			Stainless steel wash rotor
4775	75321		14U			Spacer for hub
4780	75315		14U			Rinse axle extension
4785	15040/A		14U			Lower wash bell-shape
4790	15304		14U			Lower extension axle
4795	15039		14U			Steel pipe coupling
4800	13022		14U			OR 4150 gasket
4805	15038		14U			Ring nut connection
4810	15041/A		14U			Grey wash/rinse lower distributor
4815	13003		14U			OR 112 NBR gasket
4820	12506		14U			Ø10 rubber-holder
4825	11185		14U			8x16 steel plane washer
4830	13313		14U			8x24x2 gasket
4835	70303		14U			Lower tie rod
4840	75918		14U			Top/lower rinse group
4845	75323		14U			Rinse axle
4850	13320		14U			Sliding washer
4855	11101/B		14U			Stainless steel group fixing screw
4860	560018		14U			Stainless steel rinse nozzle
4865	560017		14U			Rinse arm plug
4870	12006/A		14U			Ø10 pipe fitting 3/8x3,5 nut 19 hexagonal
4875	11702		14U			M8 stainless steel nut
4880	13316/A		14U			DVGW hole gasket