DESPIECE TECNICO

**Mantenedor de fritos
Chips scuttle
Chauffe frites
Frittenwanne
Scaldapatate
Conservador de frituras**

GAMA 900

Modelos:

MF9-05 PLUS

Julio 2013 July

FAGOR 

FAGOR INDUSTRIAL

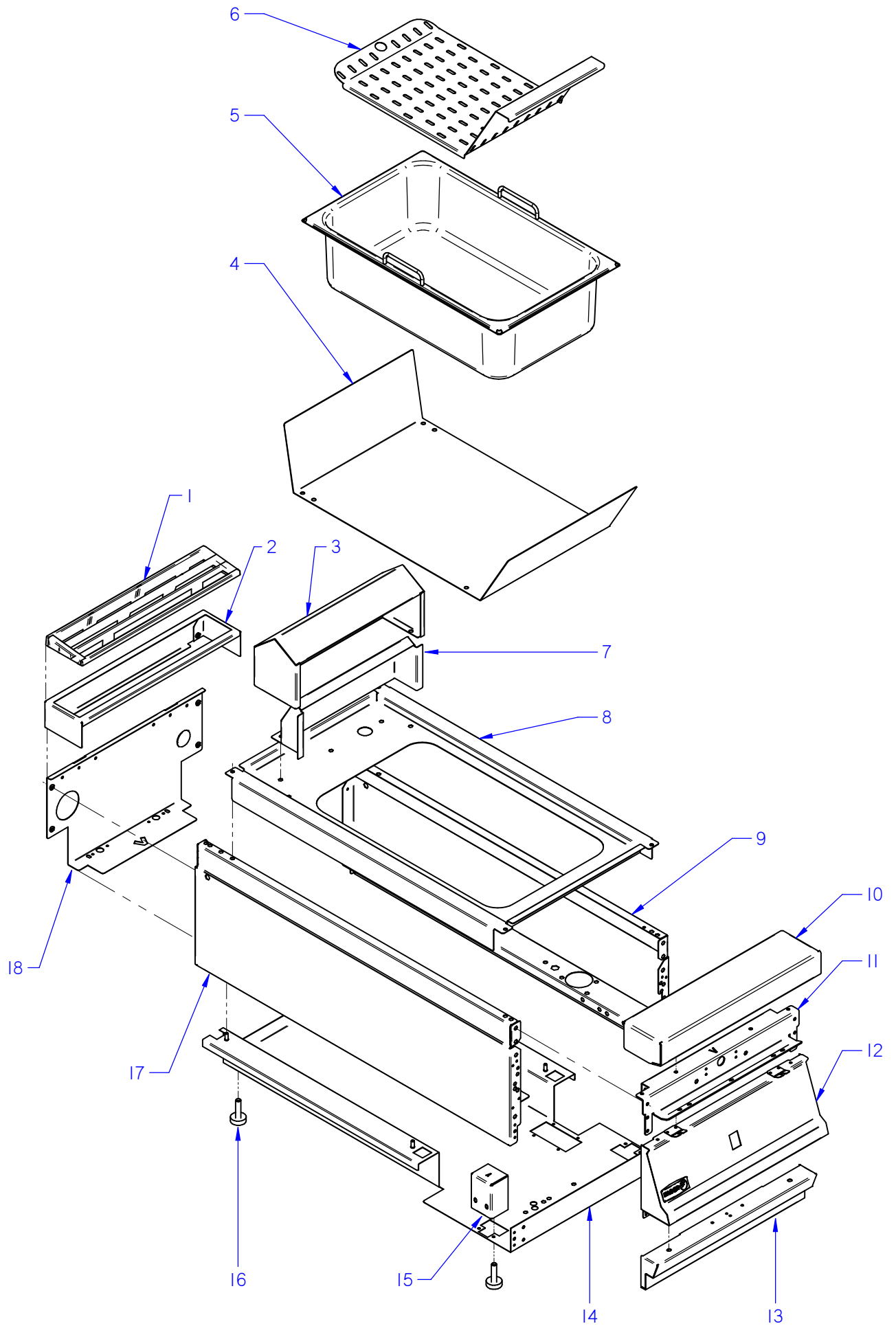

ITEM MARCADO EN COLOR = REPUESTO RECOMENDADO
 COLOURED ITEM = RECOMMENDED SPARE PART

| | | | | | | |
|---------|---------------------|---------|-------------------------------|------------------|--------|---------------------------------------|
| N plano | Firma | Fecha | Aparato | MUEBLE / FITTING | Lamina | Fagor Industrial S.Coop. FAGOR |
| C-3114 | <i>hane Bern...</i> | 2013-07 | MANTENEDOR FRITOS MF9-05 PLUS | | 1 | Oñate |

| MOD. | | MANTENEDOR DE FRITOS CHIPS SCUTTLE | | ZONA / ZONE | | MUEBLE / FITTING | | | | | | PLANO DIAGRAM | | C-3114 | |
|------|---------------------|---------------------------------------|-------------------------------|-------------|--|------------------|--|--|--|--|--|-------------------------|---------------------------|--------|--|
| ITEM | CODIGO REFERENCE | DENOMINACION | DENOMINATION | MF9-05 PLUS | | | | | | | | ELIMINADO ELIMINATED | INTRODUCID. INTRODUCED | NOTAS | |
| 1 | 12007683 | EMBELLECEDOR ESMALTE | ENAMEL TRIM | 1 | | | | | | | | | | | |
| 2 | 12038753 | SOPORTE EMBELLECEDOR 1/2M | 1/2M TRIM SUPPORT | 1 | | | | | | | | | | | |
| 3 | 12046871 | PROTECCION LAMPARA MF9-05 | TRIM PROTECTION 1M | 1 | | | | | | | | | | | |
| | 12023877 | CLIP CIERRE | LOCK SPRING | 2 | | | | | | | | | | | |
| 4 | 12041273 | PROTECTOR CABLEADO MF9-05 | WIRING PROTECTOR MF9-05 | 1 | | | | | | | | | | | |
| | 12010238 | TORNILLO EXAGONAL M5x10 A304 | HEXAGONAL BOLT M5x10 A304 | 2 | | | | | | | | | | | |
| 5 | 12009430 | FUENTE 1/1 CON ASA | DISH 1/1 WITH HANDLE | 1 | | | | | | | | | | | |
| 6 | 12001951 | PANEL SEPARADOR | PANEL SEPARATOR | 1 | | | | | | | | | | | |
| 7 | 12041624 | SOPORTE LAMPARA MF9-05 | LAMP SUPPORT MF9-05 | 1 | | | | | | | | | | | |
| | 12010238 | TORNILLO EXAGONAL M5x10 A304 | HEXAGONAL BOLT M5x10 A304 | 2 | | | | | | | | | | | |
| 8 | 12046829 | ENCIMERA MF9-05 | TOP MF9-05 | 1 | | | | | | | | | | | |
| | 12010238 | TUERCA EXAGONAL M5X10MM | HEXAGONAL NUT M5X10MM | 4 | | | | | | | | | | | |
| 9 | 12004213 | PANEL LATERAL DERECHO G9-00 | RIGHT SIDE PANEL G900 | 1 | | | | | | | | | | | |
| | Q221342000 | REMACHE EXAGONAL M5 | HEXAGONAL RIVET M5 | 6 | | | | | | | | | | | |
| 10 | 12006768 | ANTERIOR MESA 0,5 M AD | BENCH FRONT 0.5 M AD | 1 | | | | | | | | | | | |
| 11 | 12001427 | ESCUA. AMARRE ANTER.1/2 M AD | FRONT FAS. BRACKET 1/2 M AD | 1 | | | | | | | | | | | |
| | Q221342000 | REMACHE EXAGONAL M5 | HEXAGONAL RIVET M5 | 3 | | | | | | | | | | | |
| | Q012032000 | TORNILLO EXAGONAL M5X15 A304 | HEXAGONAL BOLT M5X15 A304 | 6 | | | | | | | | | | | |
| 12 | 12046828 | PORTAMANDOS COMPL. MF9-05 | CONTROL HOLDER MF9-05 | 1 | | | | | | | | | | | |
| | Q221342000 | REMACHE EXAGONAL M5 | HEXAGONAL RIVET M5 | 2 | | | | | | | | | | | |
| | Q151336000 | TORNILLO SOPORTE GUIAS | GUIDE SUPPORT BOLT | 2 | | | | | | | | | | | |
| | Q152004000 | TORNIL. APLASTADO M5X13 A 304 | FLAT HEADED SCREW M5x13 A 304 | 2 | | | | | | | | | | | |
| | 12009010 | ESCUDO FAGOR | FAGOR EMBLEM G700 | 1 | | | | | | | | | | | |
| | 12010219 | CLIP SUJECIÓN RÁPIDA Ø5 | RAPID CONNECT CLIP Ø5 | 2 | | | | | | | | | | | |
| 13 | 12001429 | ZOCALO | SKIRTING | 1 | | | | | | | | | | | |
| | Q012042000 | TORNILLO EXAGONAL M6x16 A304 | HEXAGONAL BOLT M6x16 A304 | 2 | | | | | | | | | | | |
| | Q302022000 | ARANDELA 16x6x1,2 A304 | WASHER 16x6x1.2 A304 | 2 | | | | | | | | | | | |
| 14 | 12003304 | BASE INFERIOR BME9-05 AD | LOWER BASE BME9-05 AD | 1 | | | | | | | | | | | |
| | | | | | | | | | | | | | | | |
| | | | | | | | | | | | | | | | |
| | | | | | | | | | | | | | | | |

| MOD. | | | | | | | | | | | | | | |
|---|-----------------------------|------------------------------|---------------------------|--------------------|--|--|-------------------------|--|--|--|--|---------------------------------|-----------------------------------|---------------|
| MANTENEDOR DE FRITOS CHIPS SCUTTLE | | | | ZONA / ZONE | | | MUEBLE / FITTING | | | | | | PLANO DIAGRAM | C-3114 |
| ITEM | CODIGO REFERENCE | DENOMINACION | DENOMINATION | MF9-05 PLUS | | | | | | | | ELIMINADO ELIMINATED | INTRODUCID. INTRODUCED | NOTAS |
| 15 | 12038837 | ESCUADRA AMARRE PATA AD | LEG FASTENING BRACKET AD | 2 | | | | | | | | | | |
| | 12008460 | CIERRE MUELLE | LOCK SPRING | 2 | | | | | | | | | | |
| | Q419007000 | REMACHE TUBULAR C/V Ø3,2x6 | TUBULAR RIVET C/V Ø3.2X6 | 4 | | | | | | | | | | |
| | Q162030000 | TUERCA EXAGONAL M5 | HEXAGONAL NUT M5 | 4 | | | | | | | | | | |
| | Q262030000 | ARANDELA GROW. A5 A304 | WASHER GROW. A5 A.304 | 4 | | | | | | | | | | |
| 16 | 12024163 | PATA REGULABLE | ADJUSTABLE LEG | 4 | | | | | | | | | | |
| | Q221342000 | REMACHE EXAGONAL M5 | HEXAGONAL RIVET M5 | 6 | | | | | | | | | | |
| 17 | 12004214 | PANEL LATERA IZQUIERDO G-900 | LEFT SIDE PANEL G-900 | 1 | | | | | | | | | | |
| | Q221342000 | REMACHE EXAGONAL M5 | HEXAGONAL RIVET M5 | 6 | | | | | | | | | | |
| 18 | 12001432 | PANEL POSTERIOR 1/2M AD | REAR PANEL 1/2M AD | 1 | | | | | | | | | | |
| | Q419005000 | REMACHE 4x8 ALMG3 / ALUMINIO | RIVET 4X8 ALMG3 ALUMINIUM | 4 | | | | | | | | | | |
| | 12008460 | CIERRE MUELLE | LOCK SPRING | 4 | | | | | | | | | | |
| | | | | | | | | | | | | | | |
| | | | | | | | | | | | | | | |
| | | | | | | | | | | | | | | |
| | | | | | | | | | | | | | | |
| | | | | | | | | | | | | | | |
| | | | | | | | | | | | | | | |
| | | | | | | | | | | | | | | |
| | | | | | | | | | | | | | | |
| | | | | | | | | | | | | | | |
| | | | | | | | | | | | | | | |
| | | | | | | | | | | | | | | |
| | | | | | | | | | | | | | | |
| | | | | | | | | | | | | | | |
| | | | | | | | | | | | | | | |

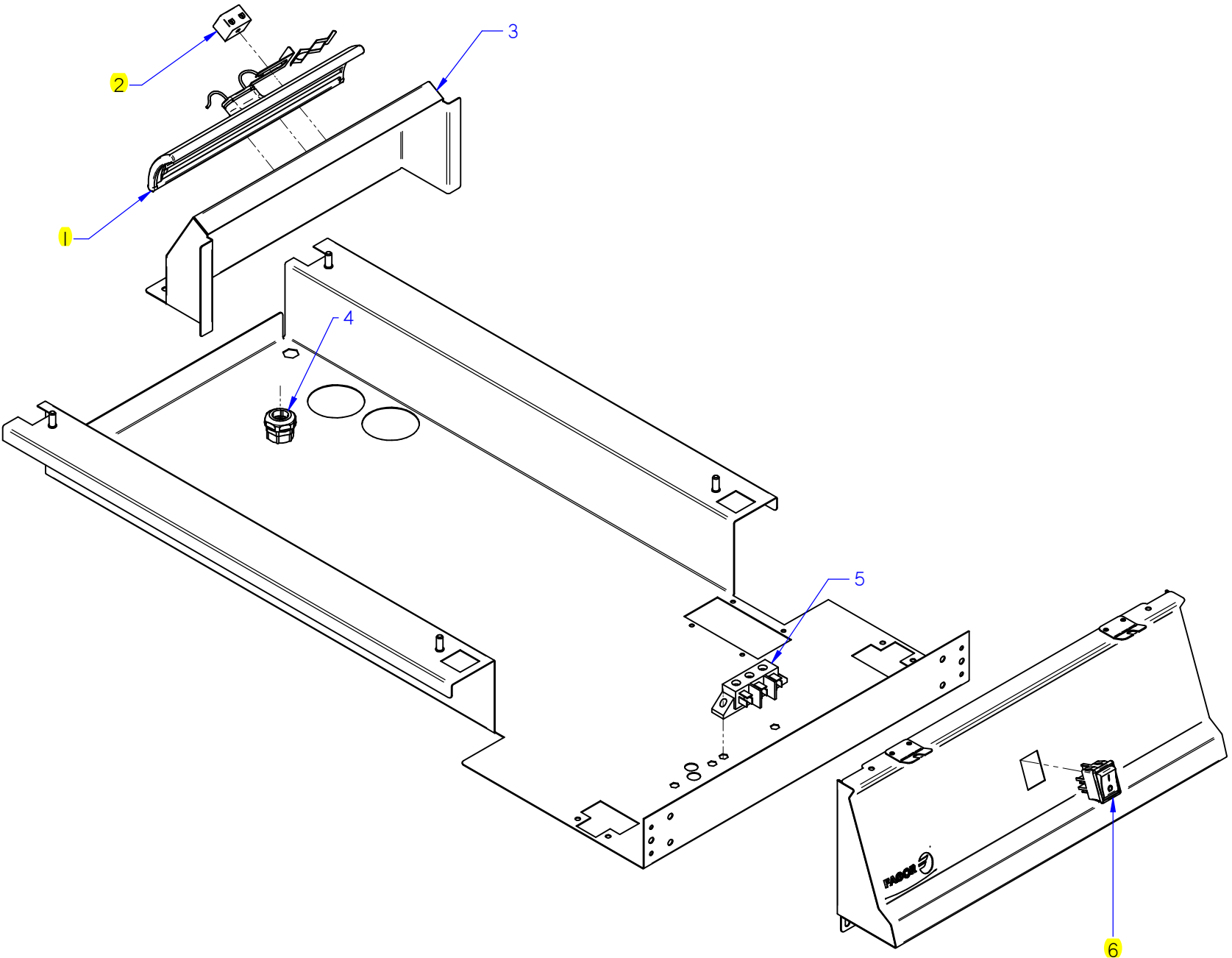

ITEM MARCADO EN COLOR = REPUESTO RECOMENDADO
COLOURED ITEM = RECOMMENDED SPARE PART

| | |
|------------------------------------|-------------------------------|
| N plano | C-3115 |
| Firma | |
| Fecha | 2013-07 |
| Aparato | MANTENEDOR FRITOS MF9-05 PLUS |
| PARTIE FUNCIONAL / FUNCTIONAL PART | Lamina |
| | 2 |
| Fagor Industrial S. Coop. | Omate |
| | |

| | | | | | |
|------|---|-------------|--|------------------|---------------|
| MOD. | MANTENEDOR DE FRITOS CHIPS SCUTTLE | ZONA / ZONE | PARTE FUNCIONAL / FUNCTIONAL PART | PLANO DIAGRAM | C-3115 |
|------|---|-------------|--|------------------|---------------|

| ITEM | CODIGO REFERENCE | DENOMINACION | DENOMINATION | MF9-05 PLUS | | | | | | | | ELIMINADO ELIMINATED | INTRODUCID. INTRODUCED | NOTAS |
|------|---------------------|-------------------------------|-------------------------------|-------------|--|--|--|--|--|--|--|-------------------------|---------------------------|-------|
| 1 | 12024220 | RESISTENCIA INFRARROJOS | RESISTANCE INFRARED | 1 | | | | | | | | | | |
| 2 | 12023534 | REGLETA CERAMICA CP6-05 | CERAMIC TERMINAL STRIP | 1 | | | | | | | | | | |
| 3 | 12041624 | SOPORTE LAMPARA MF9-05 | LAMP SUPPORT MF9-05 | 1 | | | | | | | | | | |
| 4 | 12009966 | PRENSA ESTOPAS | STUFFING BOX | 1 | | | | | | | | | | |
| | 12010121 | CONTRATUERCA GAES | COUNTERNUT GAES | 1 | | | | | | | | | | |
| | 12010046 | JUNTA GOMA (GAES) | RUBBER SEAL (GAES) | 1 | | | | | | | | | | |
| 5 | 12024382 | REGLETA 40A 10mm2 3vía 5MM | TERMINAL 40A 10mm2 3vía 5MM | 1 | | | | | | | | | | |
| | Q152004000 | TORNIL. APLASTADO M5X13 A 304 | FLAT HEADED SCREW M5x13 A 304 | 2 | | | | | | | | | | |
| 6 | 12024356 | INTERRUPTOR GENERAL | POWER SWITCH | 1 | | | | | | | | | | |
| | | | | | | | | | | | | | | |
| | | | | | | | | | | | | | | |
| | | | | | | | | | | | | | | |
| | | | | | | | | | | | | | | |
| | | | | | | | | | | | | | | |
| | | | | | | | | | | | | | | |
| | | | | | | | | | | | | | | |
| | | | | | | | | | | | | | | |
| | | | | | | | | | | | | | | |
| | | | | | | | | | | | | | | |
| | | | | | | | | | | | | | | |
| | | | | | | | | | | | | | | |
| | | | | | | | | | | | | | | |
| | | | | | | | | | | | | | | |
| | | | | | | | | | | | | | | |
| | | | | | | | | | | | | | | |
| | | | | | | | | | | | | | | |
| | | | | | | | | | | | | | | |
| | | | | | | | | | | | | | | |

| | | | | |
|------|---------------------------------------|-------------|------------------------|------------------|
| MOD. | MANTENEDOR DE FRITOS CHIPS SCUTTLE | ZONA / ZONE | VARIOS / MISCELLANEOUS | PLANO DIAGRAM |
|------|---------------------------------------|-------------|------------------------|------------------|

| ITEM | CODIGO REFERENCE | DENOMINACION | DENOMINATION | MF9-05 PLUS | | | | | | | | | ELIMINADO ELIMINATED | INTRODUCID. INTRODUCED | NOTAS |
|------|---------------------|-----------------------------|-----------------------------|-------------|--|--|--|--|--|--|--|--|-------------------------|---------------------------|-------|
| | 12002612 | FOLLETO DE INSTRUCCIONES MF | INSTRUCTION LEAFLET MF | 1 | | | | | | | | | | | |
| | 12002091 | ESQUEMA TEORICO MF6-05 | THEORETICAL DIAGRAM MF6-05 | 1 | | | | | | | | | | | |
| | 12005531 | ESQUEMA MONTAJE | ASSEMBLY DIAGRAM | 1 | | | | | | | | | | | |
| | 12025117 | INSTALAC. ELECTRICA CP6-05 | ELECTR. INSTALLATION CP6-05 | 1 | | | | | | | | | | | |
| | 12023746 | CABLE ALIMENTACION | POWER WIRING | 1 | | | | | | | | | | | |
| | 12046142 | CABLEADO TENSOR PORTAMAND | TENSIONER WIRING PORTAM. | 1 | | | | | | | | | | | |
| | | | | | | | | | | | | | | | |
| | | | | | | | | | | | | | | | |
| | | | | | | | | | | | | | | | |
| | | | | | | | | | | | | | | | |
| | | | | | | | | | | | | | | | |
| | | | | | | | | | | | | | | | |
| | | | | | | | | | | | | | | | |
| | | | | | | | | | | | | | | | |
| | | | | | | | | | | | | | | | |
| | | | | | | | | | | | | | | | |
| | | | | | | | | | | | | | | | |
| | | | | | | | | | | | | | | | |
| | | | | | | | | | | | | | | | |
| | | | | | | | | | | | | | | | |
| | | | | | | | | | | | | | | | |
| | | | | | | | | | | | | | | | |
| | | | | | | | | | | | | | | | |

| MOD. | MANTENEDOR DE FRITOS CHIPS SCUTTLE | | ZONA / ZONE | REPUESTOS RECOMENDADOS RECOMMENDED SPARE PART | | | | | | | | PLANO DIAGRAM | | |
|------|---------------------------------------|-------------------------|------------------------|--|--|--|--|--|--|--|--|-------------------------|---------------------------|--------|
| ITEM | CODIGO REFERENCE | DENOMINACION | DENOMINATION | MF9-05 PLUS | | | | | | | | ELIMINADO ELIMINATED | INTRODUCID. INTRODUCED | NOTAS |
| 1 | 12024220 | RESISTENCIA INFRARROJOS | RESISTANCE INFRARED | 1 | | | | | | | | | | C-3115 |
| 2 | 12023534 | REGLETA CERAMICA CP6-05 | CERAMIC TERMINAL STRIP | 1 | | | | | | | | | | C-3115 |
| 6 | 12024356 | INTERRUPTOR GENERAL | POWER SWITCH | 1 | | | | | | | | | | C-3115 |
| | | | | | | | | | | | | | | |
| | | | | | | | | | | | | | | |
| | | | | | | | | | | | | | | |
| | | | | | | | | | | | | | | |
| | | | | | | | | | | | | | | |
| | | | | | | | | | | | | | | |
| | | | | | | | | | | | | | | |
| | | | | | | | | | | | | | | |
| | | | | | | | | | | | | | | |
| | | | | | | | | | | | | | | |
| | | | | | | | | | | | | | | |
| | | | | | | | | | | | | | | |
| | | | | | | | | | | | | | | |
| | | | | | | | | | | | | | | |
| | | | | | | | | | | | | | | |
| | | | | | | | | | | | | | | |
| | | | | | | | | | | | | | | |

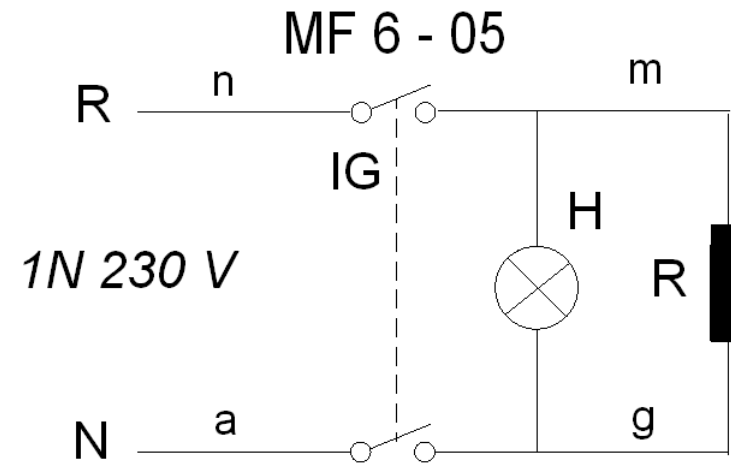

a = azul-blue m = marron - brown g = gris - grey n = negro-black
 IG: Interruptor general/Main switch
 H: Piloto encendido / Operation light
 R: Resistencia/Resistance

J273002000

| | | | | | | |
|------------------------|---|------------|--|--------------------|--|---|
| - | Theoretical diagram: MF | | - | - | J273002000 | - |
| Zk./N° | Pieza | Cant. | Materiala/Material | Klas. zk./N° Clas. | Gainazal akabera/Tratamiento | |
| Zk./N° | Aldaketa/Modificaciones | | Nork proposatua/Propuesta de | Data/Fecha | Perdoi orokorrak Tolerancias generales | |
| - | - | - | - | - | $\leq 5 \pm 0.2$ $50 - 100 \pm 0.8$ $5 + 25 \pm 0.4$ $> 100 \pm 1$ $25 + 50 \pm 0.6$ $\varnothing \pm 1$ | |
| | Sinadura/Firma | Data/Fecha |  Fagor Industrial, Koop. Elk., Mugatua | | Gainazal perdoia Mecanizado superficial | |
| Marratzua/Dibujado | e.carrascal | 2008-11-12 | | | - | |
| Proiektatua/Proyectado | e.carrascal | 2008-11-12 | | | - | |
| Egiaztatua/Comprobado | <i>f.alberdi</i> | 2008-11-12 | | | - | |
| Eskala/Escala | COOKING | | | | Plano Zk./Plano N° HB-80537 | |
| - | Plano hau ezin daiteke erabili, ez berrizatu, gure baimenik gabe. | | | | - Zk. ord. du - Zk.gaitik ord. | |

MF 605

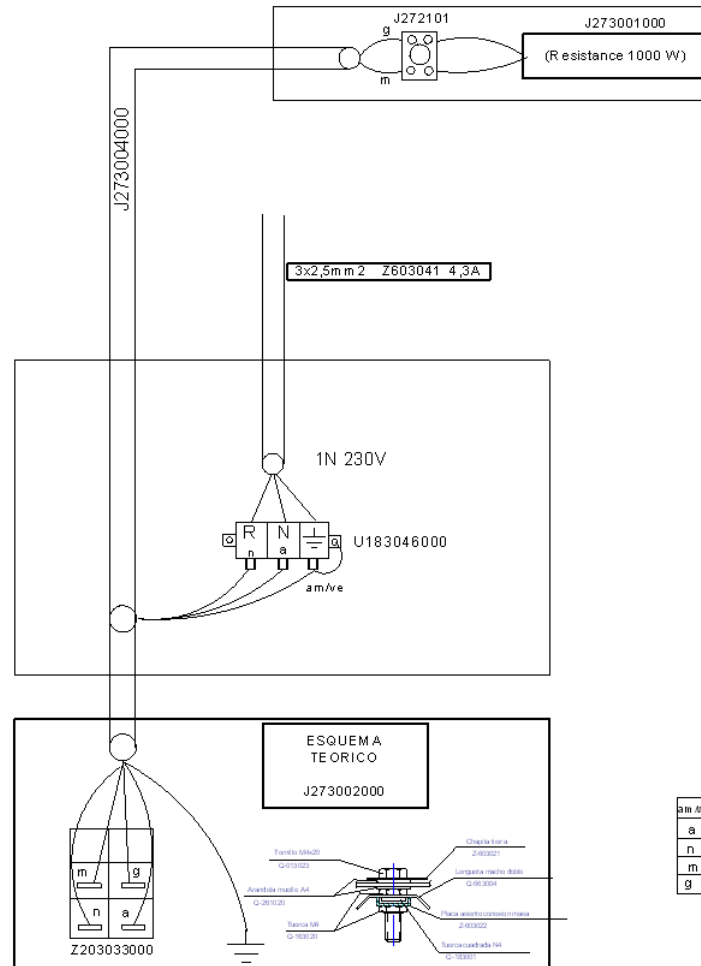

| COLORS | | |
|--------|----------------|--------------|
| am/te | amarillo/verde | yellow/green |
| a | azul | blue |
| n | negro | black |
| m | marron | brown |
| g | gris | grey |

| - PLANO MONTAJE MF 605 | | - J273003000 | |
|---|-------------------------|--------------|--|
| Zk./N° | Pieza | Cant. | Materia/Material |
| Zk./N° | Aldaketa/Modificaciones | | Nork proposatua/Propuesta de |
| - | - | - | - |
| - | - | - | - |
| - | - | - | - |
| - | - | - | - |
| - | - | - | - |
| Sinadura/Firma | | Data/Fecha | |
| Marratzua/Dibujado | M.Maillo | 2009-05-12 | |
| Proiektatua/Proyectado | M.Maillo | 2009-05-12 | |
| Egiaztatua/Comprobado | <i>i Alberdi</i> | 2009-05-12 | |
| Eskala/Escala | | | |
| CHIPS SCUTTLE | | | Gainazal akabera/Tratamiento |
| Plano hau ezin daiteke erabili, ez berrizatu, gure baimenik gabe. | | | Gainazal perdoia Mecanizado superficial |
| - Zk. ord. du | | | Plano Zk./Plano N° HB-80539 |
| - Zk.gaitik ord. | | | |