

Vorbereitung Aufschnittmaschinen

Artikel-Nr. 411005
(15223302W (Mira 220C))

Explosionszeichnung

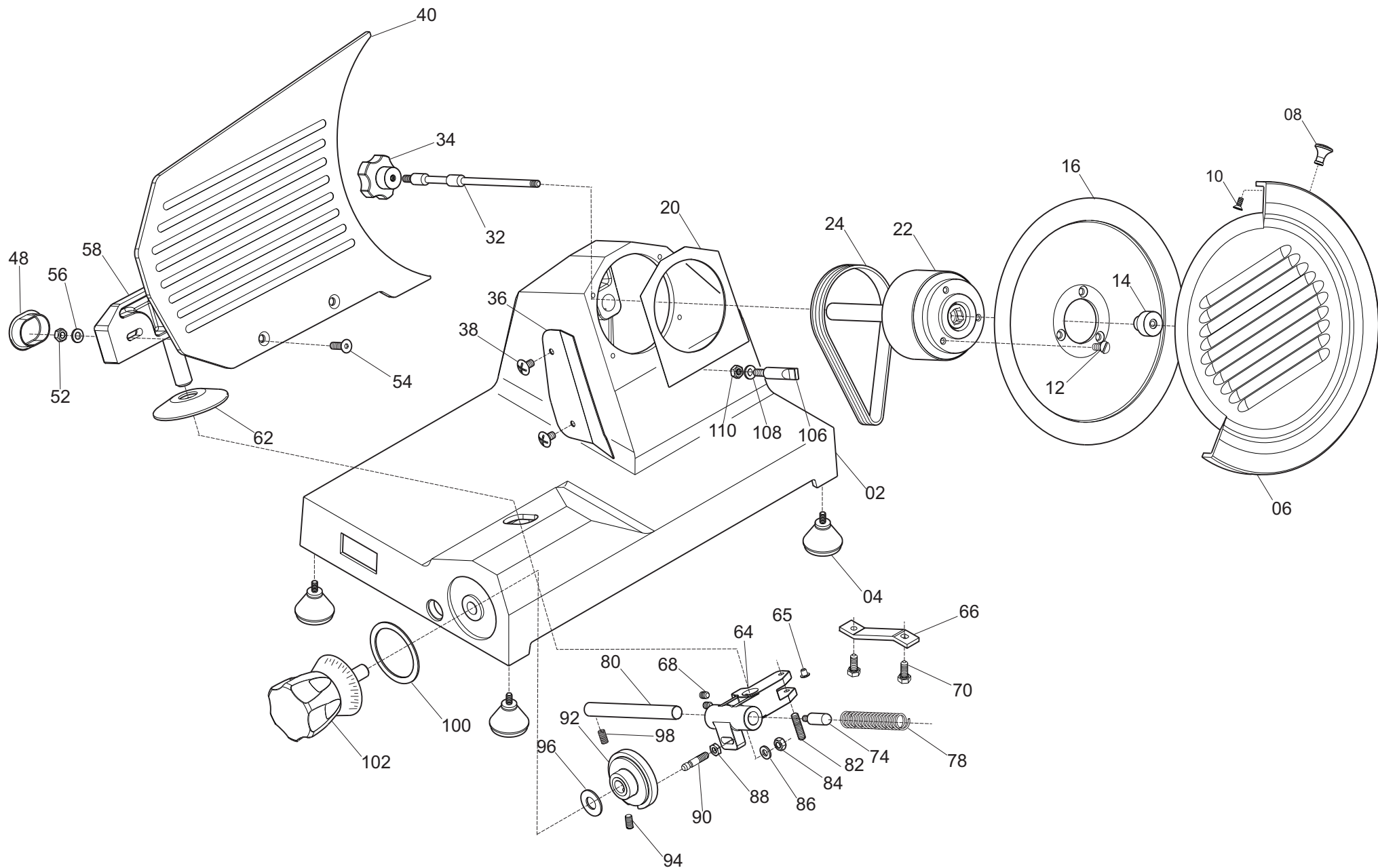

Name
Zeichnung *MIRRA 220 NW*

:

Ref.	Produktname	Artikel-Nr
02	CASSA SG 220-250 MRR C OSSIDATA	19510101/01
04	PIEDINO PICCOLO DOPPIO M 5	19560201
06	PARALAMA 220 AFFIL.INC. OSSIDATO	19510203
08	POMELLO PARALAMA LAV	19021110
100	RONDELLA PLEX MAN.NUM. MRR	19562145
102	MANOPOLA NUMER.MRR PERNO D.12MM	19562402
106	FERMO PARALAMA MRR 220/250 STA.NUO	19531350/02
14	SPESS.ALL. PARALAMA MRR 250 02 ST	19521610/02
16A	LAMA 220 - 40/3/180 NAZ.	18220403180
16B	LAMA 220 - 40/3/180 TEFLONATA	18220403180T
20	PARA ACQUA PULEG.MRR 220/250 NUOVO	19562124
22	PULEG.PRES.MONT.MRR. 220-300	19700340
24	CINGH.PIAT.MRR TB2 345 X 8	19310201
32	TIRANTE PARALAMA MRR 220/300	19530532
34	POM. TIR.PARALAMA MRR M6X5 LOBI	19562502
36	PARAFETTA PLASTICA MRR 220 NEW	19562206
40	VELA SG 220 STAMP.DAL 06 OSSID.	195103E01
48	TAPPO SUP.VELA MRR V 220-300	19560132
54	VITE BLOCCA VELA MRR 220-250	19335060
58	SUP.VELA MRR 220-250 C. OSSIDATO	19510701/01
62	PARA ACQUA GRANDE	19563002
64	MOVIMENTO VELA MRR SG CORT LAV	19500101/01
65	FUNGHETTO MOVIMENTO D8,5XHT2	19563201

66	PIASTRINA MOV. MRR ZINCATA	19540601
74	PERNO MOLLA MOVIMENTO MRR 220/250	19531360
78	MOLLA MOVIMENTO VELA 220 250 MRR C	19390201/02
80	PERNO MOV. VELA MRR D12X122,5	19530701
82	PRIGIONIERO 6 X 25 OTTONE	19337002
90	RULLINO MOVIMENTO CAM. CORT MRR	19336062/01
92	CAMMA MRR GRAVITA.NO CE/CE DOM+MNI	19563505N
96	RONDELLA ONDULATA 12	19342005