



*SHELL ASSY*

*COOLING SYSTEM*

*HYDRAULIC CIRCUIT*

*SPRAYER PUMP*

*ELECTRIC PARTS*

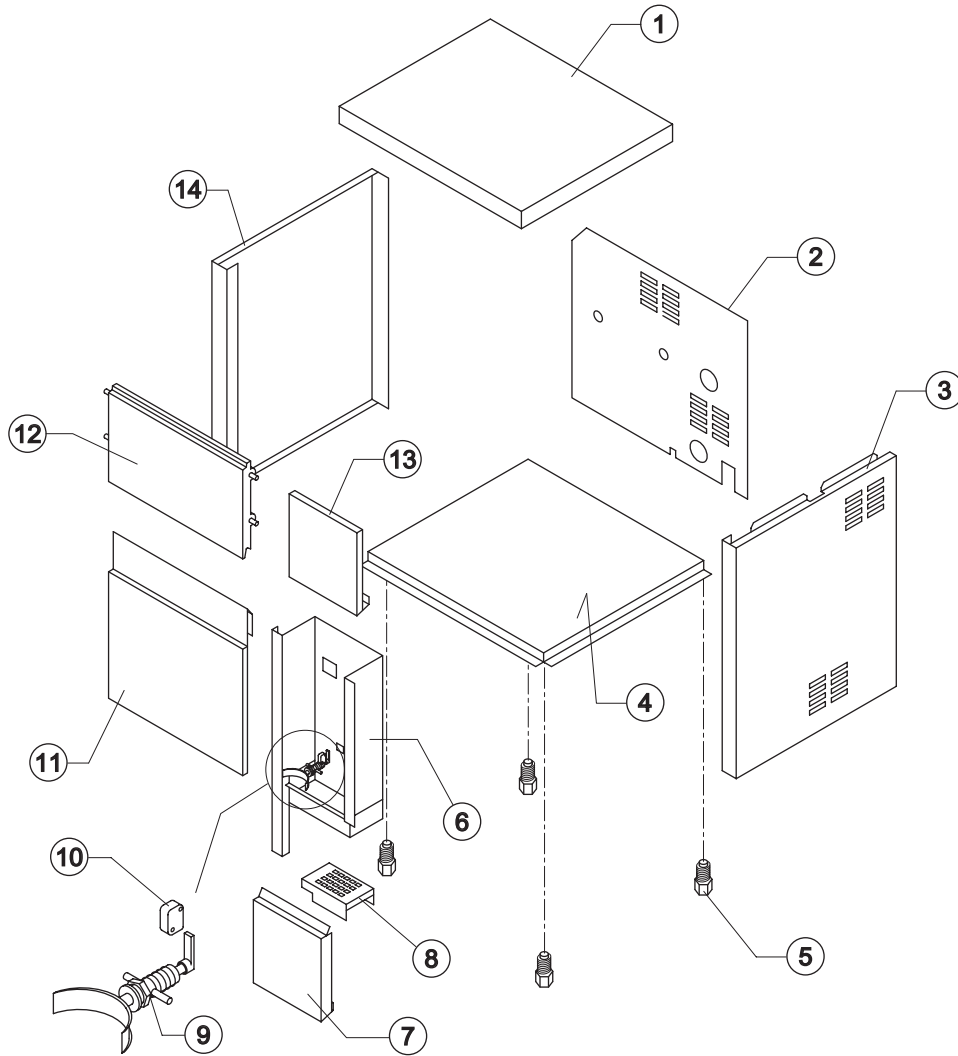

Ref.	Spare Description	Code
1	Top Assembly	C22199
2	Rear Panel	22198
3	Right Side Panel	22200
4	Base Plate	21105
5	Foot	10017
6	Ice Dispenser Panel	22273
7	Basin Cover Panel	22190
8	Glass Support	22183
9	Ice Dispenser Push Button Assembly	C26544
10	Microswitch	23055
11	Front Panel (Bin Side)	22189
12	Dark Grey Door	10277
13	Tap Cover	22197
14	Left Side Panel	22201

Rev. 6 - 31/08/2007

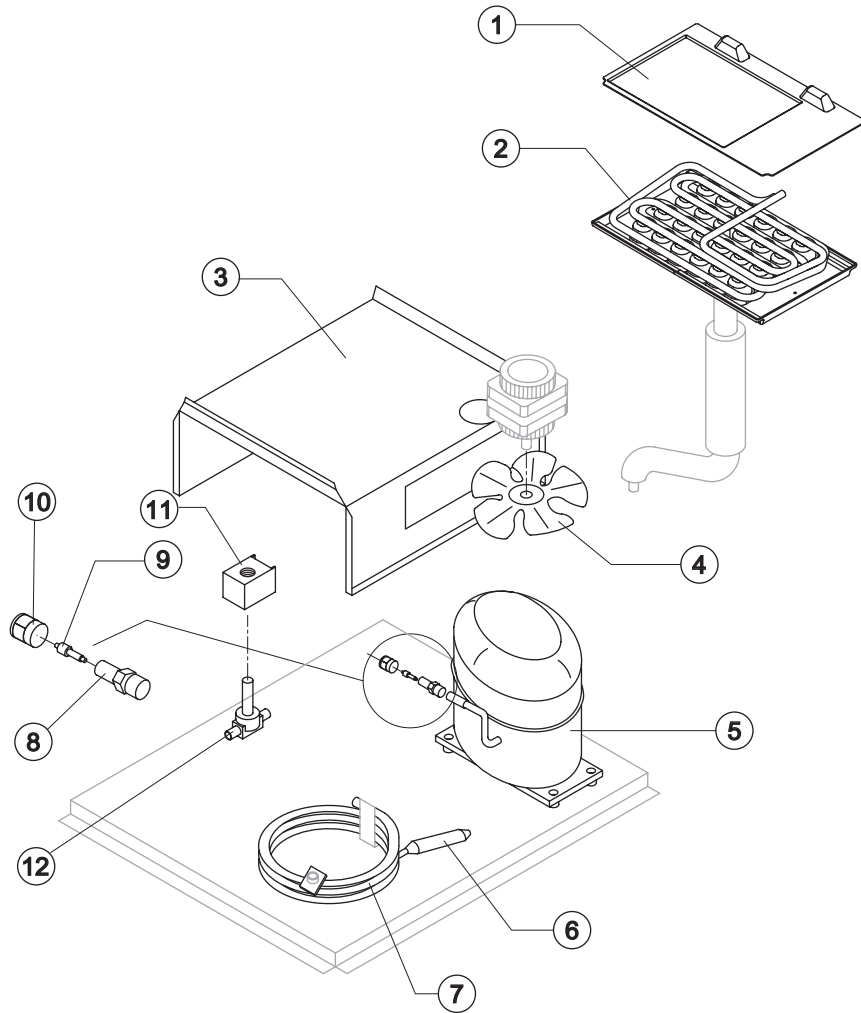

Ref.	Spare Description		Code
1	Evaporator Cover Panel	Current Version	10455
1	Evaporator Cover Panel	Till s/n. 225972	10076
2	Evaporator		D10079
3	Bin Support Frame		21108
4	Pressing Fan		20193
5	Compressor	See Table	-
6	Molecular Drier		14009
7	Water Condenser		14100
8	Vacuum-Charge Valve Body		14007
9	Vacuum-Charge Valve Device		14005
10	Vacuum-Charge Valve Plug		14006
11	Hot Gas Valve Coil	See Table	-
12	Hot Gas Valve Body		20410

### Ref. 5 - Compressor

Tension	Code
220/240V 50 Hz	23436
220/230V 60 Hz	23494
110/115V 60 Hz	23446

### Ref. 11 - Hot Gas Valve Coil

Tension	Code
220/240V 50 Hz	23091
220/230V 60 Hz	23091
110/115V 60 Hz	23256

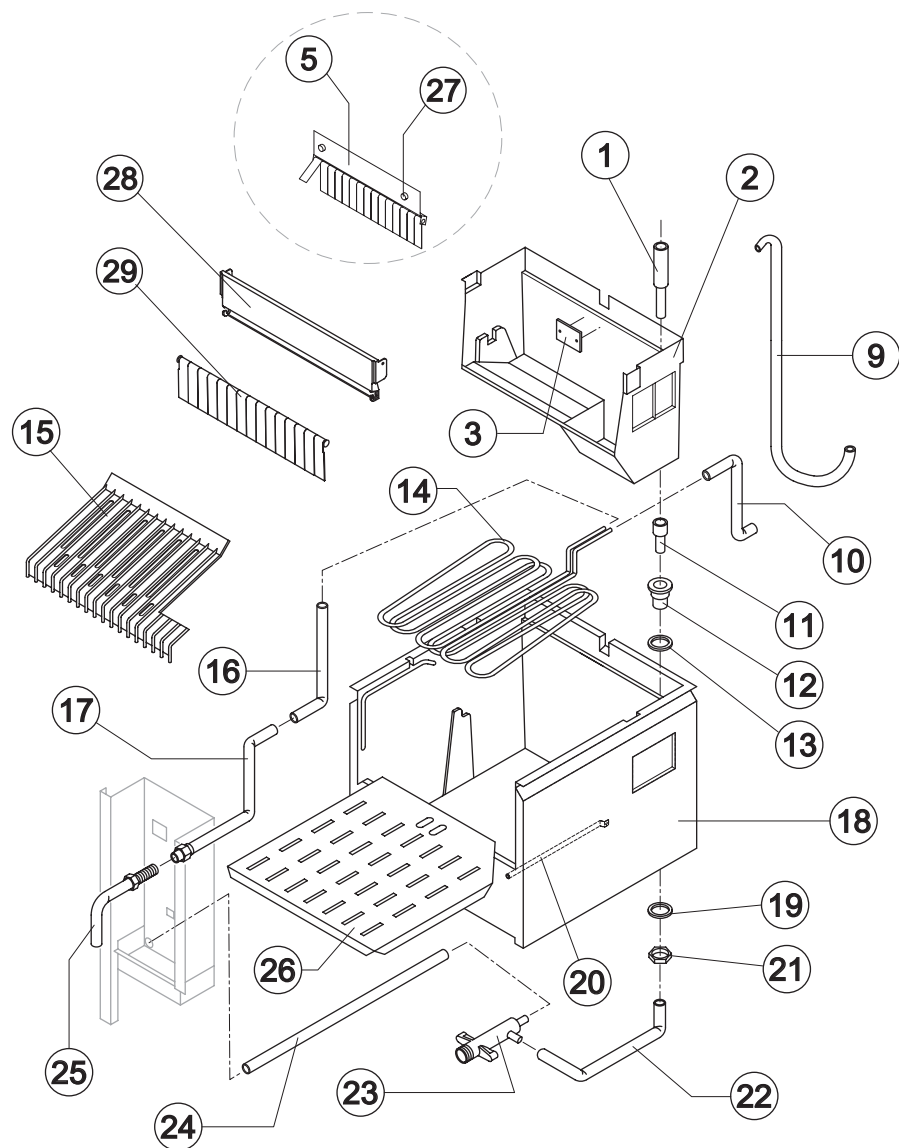

Rev. 6 - 31/08/2007

Ref.	Spare Description	Code
1	Overflow Pipe	13028
2	Inner Basin	10064
3	Slide Keep Plate	10142
5	Panel with Flags	Till s/n. 380376 C22106
9	Evaporator Feeding Pipe	C20535
10	Inlet Valve-Coil Connection Pipe	13156
11	Overflow Pipe	C13045
12	Water Outlet Nipple	10472
13	Silicone Gasket	13006
14	Water Coil	14099
15	Ice Cubes Slide	10136
16	Coil-Faucet Connection Pipe	13156
17	Tap Feeding Pipe	14102
18	Foamed Bin	R11016/E
19	Semirigid Polyethylene Gasket	13007
20	Bulbe Thermostat Tube	20520
21	Bin Discharge Nut	10096
22	Bin Discharge Pipe	13044
23	Discharge Manifold	C10121
24	Dispenser Water Discharge Pipe	13043
25	Tap	20195
26	Coil Covering Grid	22188
27	Fixing Screw	Till s/n. 380376 20009
28	Flags ABS Support	Current Version 10530
29	Rod With Flags	Currente Version C10532

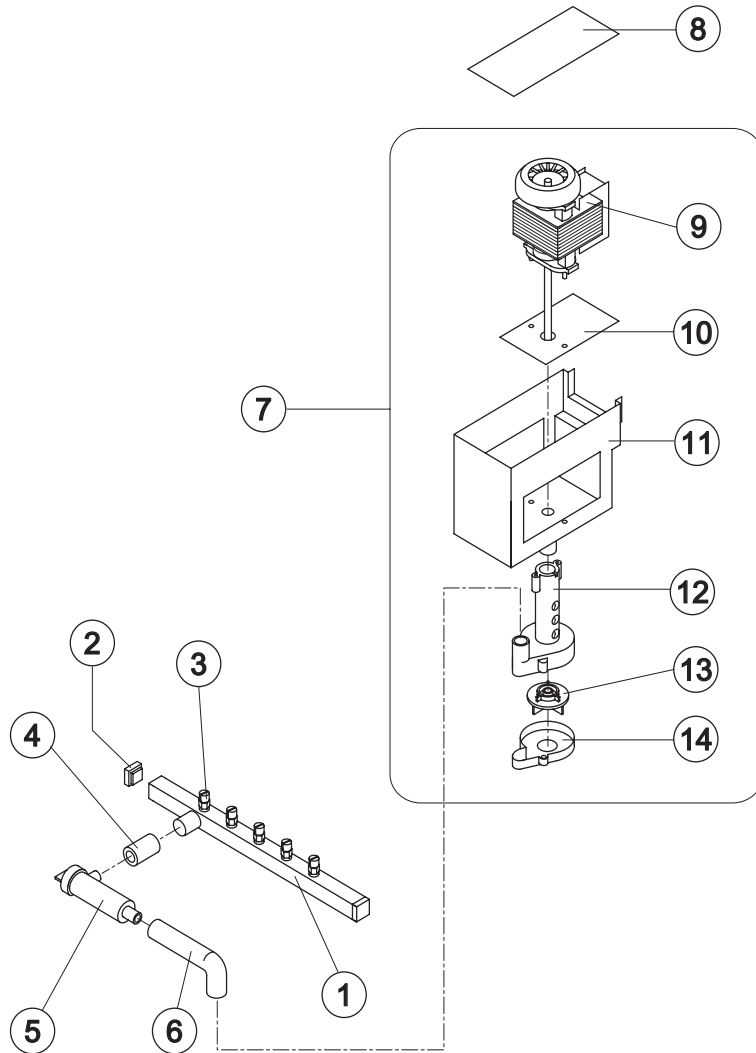

Ref.	Spare Description	Code	
1	Sprayers Bar Assembly	C20147	
2	Sprayers Bar Plug	10012	
3	Sprayer	D20002	
4	Filter-Sprayers Bar Connection Pipe	13056	
5	Pump Filter	10139	
6	Pump-Filter Connection Pipe	13055	
7	Pump Assy	See Table	-
8	Pump Cover	Till s/n. 225972	22096
9	Pump	See Table	-
10	Heat Dissipator		22430
11	Pump Motor Box		10073
12	Pump Body		10065
13	Pump Imeller		10066
14	Diffusor		10067

### Ref. 7 - Pump Assy

Tension	Code
220/240V 50 Hz	C23076
220/230V 60 Hz	C23270
110/115V 60 Hz	C23271

### Ref. 9 - Pump

Tension	Code
220/240V 50 Hz	23073
220/230V 60 Hz	23187
110/115V 60 Hz	23188

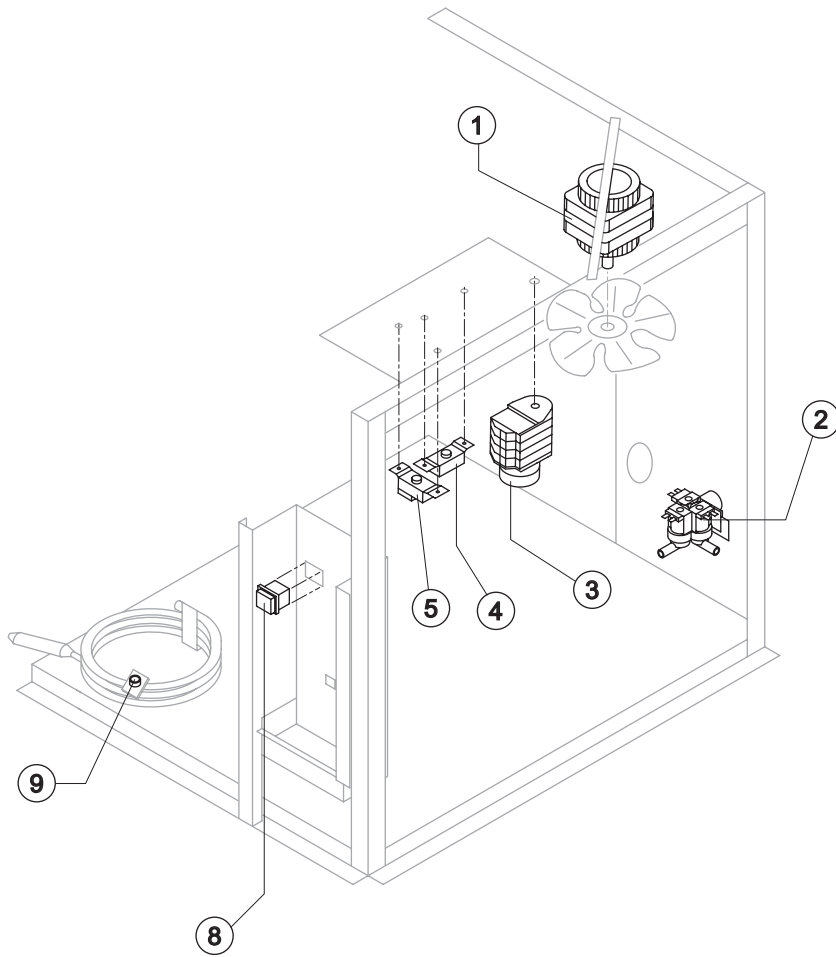

Ref.	Spare Description	Code
1	Fan Motor	See Table
2	3 Ways- Water Inlet Valve	See Table
3	Timer	See Table
4	Bin Thermostat	R23005
5	Evaporator Thermostat	R23591
8	Green Light Switch (on-Off)	23327
9	Safety Thermostat	C23114

### Ref. 1 - Fan Motor

Tension	Code
220/240V 50 Hz	23029
220/230V 60 Hz	23029
110/115V 60 Hz	23683

### Ref. 2 - 3Ways- Water Inlet Valve

Tension	Code
220/240V 50 Hz	23144
220/230V 60 Hz	23144
110/115V 60 Hz	23269

### Ref. 3 - Timer

Tension	Code
220/240V 50 Hz	23247
220/230V 60 Hz	23247
110/115V 60 Hz	23258

Rev. 6 - 31/08/2007