

WAREWASHER

ELECTRONICAL SWITCHES
DOUBLE BODY VERSION
LOWER AND UPPER VERSION

TYPE: 82E

Accessories
BOOSTER PUMP
DETERGENT DISPENSER

Spare Parts Manual

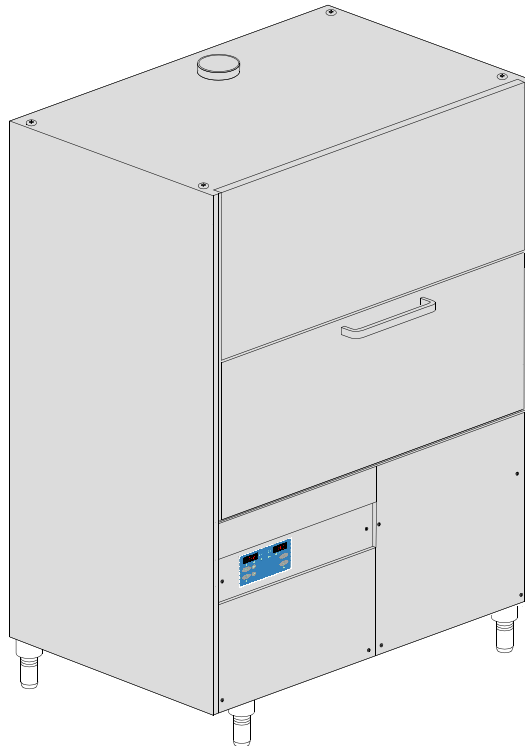

INFORMAZIONI GENERALI

Questo catalogo serve per richiedere con esattezza le parti di ricambio

Nelle ordinazioni indicare:

1) il numero dei codici dei particolari seguito dalla descrizione e la quantità desiderata;

2) Il codice alfa-numerico presente nella seconda colonna della tabella ;

I disegni delle parti di ricambio sono solo indicativi e non rappresentano il pezzo in oggetto.

I dati contenuti in questo catalogo sono indicativi e possono essere soggetti a modifiche senza impegno di preavviso.

ALLGEMEINE INFORMATIONEN

Dieser Ersatzteilkatalog dient zur genauen Angabe der Teile bei Ersatzteilbestellungen.

Bei Ersatzbestellung ist folgendes anzugeben:

1) Die Bestellnummer der Ersatzteile mit der entsprechenden Beschreibung genaue Menge;

2) Der alpha-numerischer Code auf der zweiten Reihe in dein Spcluld;

Die Zeichnungen der Ersatzteile sind nur als Hinweise gedacht und stellen nicht das betroffene Teil dar.

Bei den im Katalog angeführten Daten handelt es sich um Anhaltsdaten, die jederzeit, ohne Vorankündigung, geändert werden können.

GENERAL INFORMATION

The present spare parts order exactly the right spare parts

When ordering specify:

1) the part's code number followed by its description and quantity needed;

2) The alpha-numeric code is in the second column in the chart;

Spare parts drawings are general and do not represent the part.

The contents of this catalogue are general and can undergo changes without prior notice.

INFORMACIONES GENERALES

El presente catálogo sirve para pedir con exactitud las partes de repuesto

En los pedidos se debe indicar:

1) el número de código de la parte y a continuación la descripción cantidad deseada;

2) El código alfanumerico presente en la segnada columna de la tabla;

Los diseños de las partes de recambio son solo indicativos y no representan la pieza en cuestión.

Los datos contenidos en el presente catálogo son indicativos y pueden modificarse sin aviso previo.

INFORMATIONS GENERALES

Ce catalogue permet de commander correctement les pièces détachées

Les commandes doivent être passées en indiquant:

1) le numero de code des pièces détachées suivi de leur description quantité désirée;

2) le code alphanumérique dans la deuxième colonne du tableau;

Les plans des pièces détachées sont fournis seulement à titre indicatif et ne représentent pas la pièce concernée.

Les données de ce catalogue sont citées seulement à titre indicatif et peuvent être l'objet de modifications sans avis préalable.

ESEMPIO
EXAMPLE
EXEMPLE
BEISPIEL

Rif.	Codici
MODULE:Particolari	
10505	540903
10510	540908
10515	15065/A
10520	540086
10525	540028

Note

Tutte le informazioni riportate si intendono aggiornate alla data di stampa. Il Produttore si riserva il diritto di apportare qualsiasi modifica richiesta dallo sviluppo evolutivo dei suddetti prodotti.

Per la sicurezza, la garanzia, l'affidabilità ed il valore della lavastoviglie usa solo ricambi originali. **Per alcuni codici, sono richieste quantità minime d'ordine.**

Attenzione

Questo libretto è parte integrante della lavastoviglie e, in caso di passaggio di proprietà, deve essere consegnato al nuovo acquirente.

Remarque

Toutes les informations contenues dans ce manuel s'entendent mises à jour à la date d'impression. En raison du développement constant de ses produits, usine se réserve le droit d'apporter à tout instant les modifications qu'elle jugera utiles.

Pour la sécurité, la garantie, la fiabilité et la valeur de votre lavevaisselles n'utilisez que des pièces de rechange d'origine. **Pour quelque référence on demande un minimum de pièces par commande**

Attention

Ce manuel doit être considéré comme partie intégrante de la la lavevaisselles, en cas de transfert de propriété, doit toujours être remis au nouveau propriétaire.

Note

The information contained herein is valid at the time of going to print. The Company reserves the right to make any changes required by the future development of the above-mentioned products.

For your safety, as well as to preserve the warranty reliability and worth of your dishwashers, use original spare parts only. **For some codes a minimum quantity for order is required.**

Warning

This manual forms an integral part of the dishwashers and - if a transfer of title occurs - must always be handed over to the new owner.

Hinweis

Die Der Hersteller behält sich das Recht vor, jegliche, durch eine Weiterentwicklung der genannten Produkte bedingte Änderungen vornehmen zu können.

Verwenden Sie für Ihre Sicherheit, die Garantie, die Zuverlässigkeit und den Wert Ihrer machine originale Ersatzteile. **Für bestimmte Code nummer werden mindesten bestellungen verlangt.**

Achtung

Diese Betriebsanleitung ist Bestandteile des machine und muss bei seinem Weiterverkauf dem neuen Besitzer ausgehändigt werden.



Code 999XYYYY **CL/Part**

Model DESCRIPTION 

S/N 04012345 **Type**

400VAC3N 50HZ 8A
3500W 500W

 16A

IPX3

Pressione Dinamica alimentazione idrica **200-500**
 Pression dynamique arrivee d'eau
 Dynamic pressure water supply
 Dymanischer Druck gesattigter Dampf

Pressione dinamica vapore saturo
 Pression dynamique vapeur satuee
 Dymanischer Druck gesattigter Dampf
 Pression Dinamica Vapor Saturado

TECHICAL SPECIFICATION

MADE IN ITALY

Temperatura massima acqua in ingresso **60°C**
 Temperature max eau a l'entre
 Maximale Temperatur Wasseranschlu
 Maximum Water temperature in-feeding

Model 

S/N 

CODE 999 XX YYYY

FAMIGLIA PRODOTTO
 FAMILY PRODUCT
 FAMILLE DU PRODUIT
 FAMILIA PRODUCTO
 FAMILIE DES PRODUKTES

CODICE MODELLO
 CODE MODEL
 CODE ARTICLE
 CODIGO MODELO
 KODE VON MODELL

S/N 04 012345

ANNO
 YEAR
 ANNÉE
 AN^o
 JAHR

NUMERO DI SERIE
 SERIAL NUMBER
 NUMÉRO DI SÉRIE
 NUMERO DI SERIE
 SERIENNUMMER

1. Spare parts

General body parts.....	7
Lockup system	9
Control panel and switches.....	11
Electronic control HACCP.....	13
Electric control components.....	15
Solenoid valve group	17
Rinse with steady temperature.....	19
Rinse aid dispenser group.....	21
Wash pump	23
Dosing detergent group.....	25
Pressure switch group with air trap ...	27
Turret group with rotating arms	29

1.1 Voltage codes

Volt	Voltage code
A	3/N/PE~380-400V 50-60Hz
D	3/PE~200-210V 50-60Hz
F	2/PE~220-240V 50-60Hz
G	3/N/PE~415V 50-60Hz
H	3/PE~220-230V 50-60Hz
K	3/PE~380-400V 50-60Hz
L	3/PE~415V 50-60Hz
M	3/PE~440V 60Hz
P	1/N/PE~220-230V 50-60Hz
R	2/PE~220-240V 50-60Hz
U	1/N/PE~240V 50-60Hz
V	3/PE~240V 50-60Hz
W	1/N/PE~100-110V 50-60Hz

1.2 Product codes

Product code	Full name
Model codes	
e	ELECTRONICAL SWITCHES
dc	DOUBLE BODY VERSION
uw	LOWER AND UPPER VERSION
Type codes	
82E	82E
Accessory codes	
bp	BOOSTER PUMP
dd	DETERGENT DISPENCER

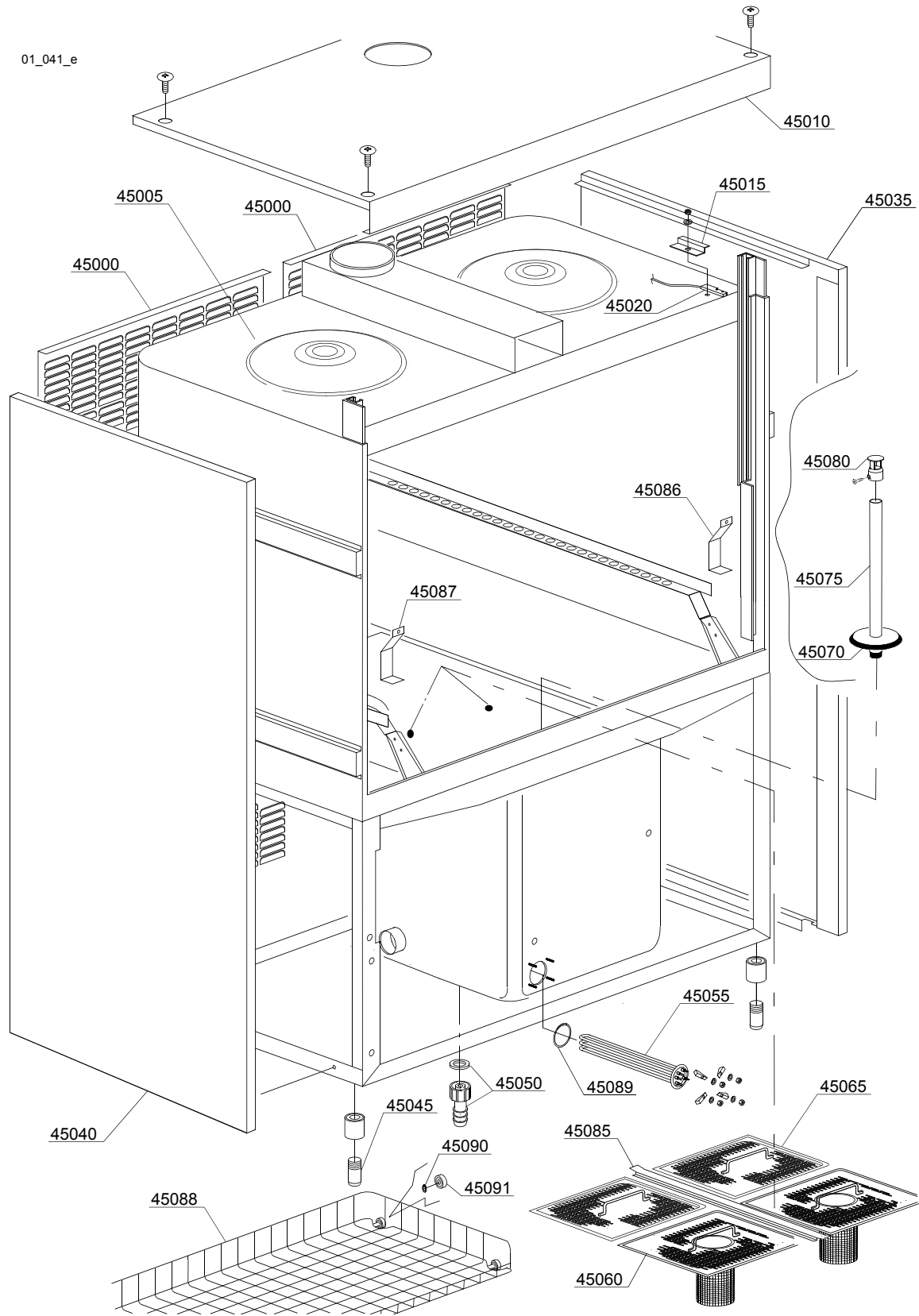

Spare parts

ID	P-code	SN from	SN to	Mod.	Acces.	Volt	Description
Module:General body parts							
45000	93504		-	e,dc			Back panel
45005	93500		-	e,dc			Body with complete door
45010	93505		-	e,dc			Tank
45015	3009112		-	e,dc			Support microswitch
45020	3003112		-	e,dc			Door microswitch
45035	93502		-	e,dc			Right lower panel
45040	93503		-	e,dc			Left lower panel
45045	15116		-	e,dc			Foot
45050	15613		-	e,dc			Elbow 1¼"
45055	30001011		-	e,dc		A,H,K,L,P,R,U,V	Heating element 9000 / 9800W 230/240V 3
45060	11600906		-	e,dc			Front surface filter
45065	11600907		-	e,dc			Back surface filter
45070	11600002		-	e,dc			Packing to flange
45075	93601		-	e,dc			Overflow pipe tube
45080	11600019		-	e,dc			End overflow pipe tube
45085	93509		-	e,dc			Axis support filters
45086	80936		-	e,dc			Right splash guard
45087	80937		-	e,dc			Left splash guard
45088	93600		-	e,dc			Inox rack with wheel
45089	13015		-	e,dc			O-ring 6225 OR 160 NBR
45090	89919/A		-	e,dc			Inox seger Ø 8
45091	89919		-	e,dc			Plastic wheel

e=ELECTRONICAL SWITCHES, dc=DOUBLE BODY VERSION, uw=LOWER AND UPPER VERSION

82E=82E

bp=BOOSTER PUMP, dd=DETERGENT DISPENCER

A=3/N/PE~380-400V 50-60Hz, D=3/PE~200-210V 50-60Hz, F=2/PE~220-240V 50-60Hz, G=3/N/PE~415V 50-60Hz, H=3/PE~220-230V 50-60Hz, K=3/PE~380-400V 50-60Hz, L=3/PE~415V 50-60Hz, M=3/PE~440V 60Hz, P=1/N/PE~220-230V 50-60Hz, R=2/PE~220-240V 50-60Hz, U=1/N/PE~240V 50-60Hz, V=3/PE~240V 50-60Hz, W=1/N/PE~100-110V 50-60Hz

02_130_e

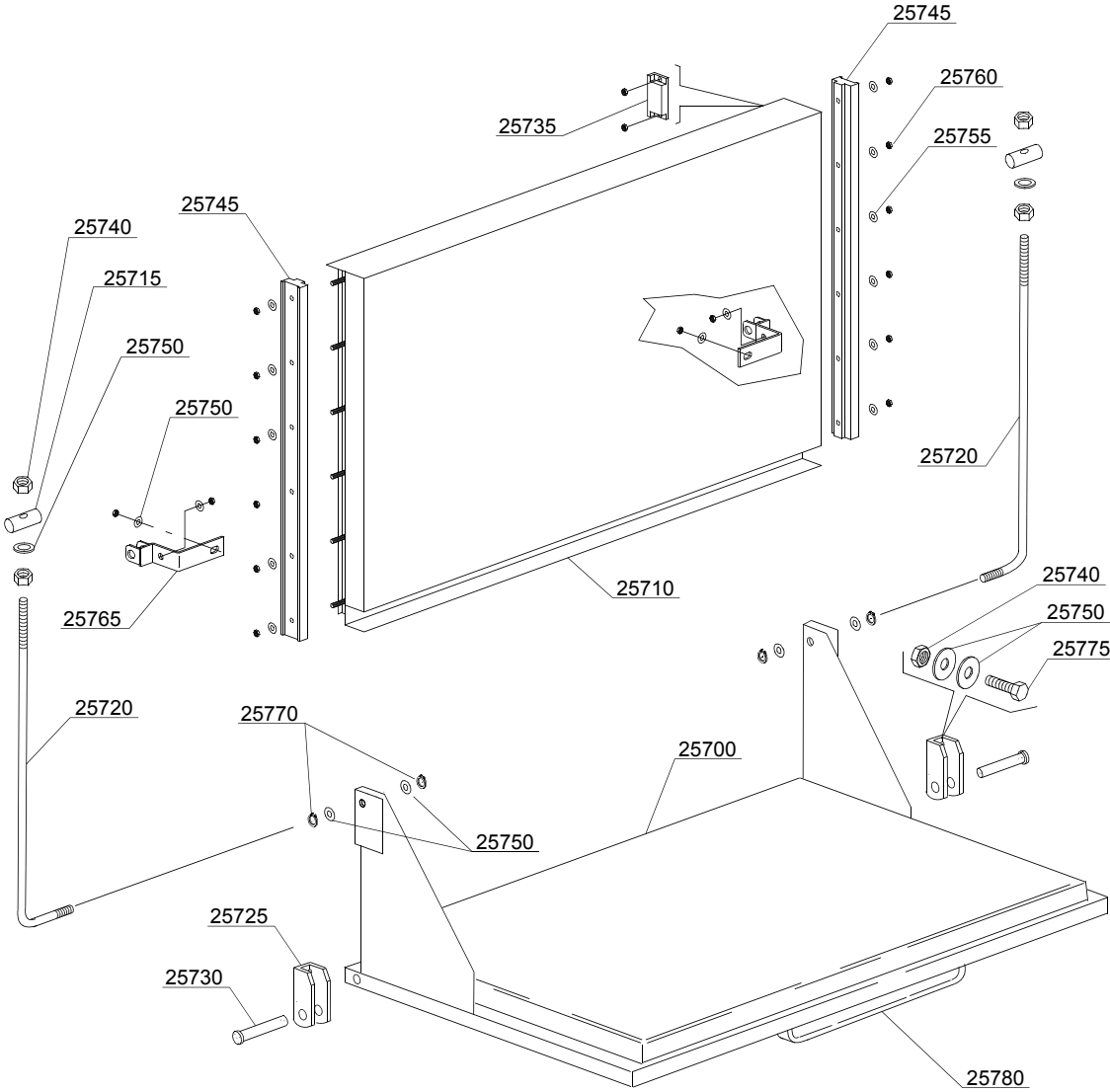

Spare parts

ID	P-code	SN from	SN to	Mod.	Acces.	Volt	Description
Module: Lockup system							
25700	93500/A		-	e			Door with steel handle
25710	93500/B		-	e			Upper door
25715	22219		-	e			Door rod pin
25720	22220		-	e			Door rod
25725	22206/B		-	e			Door hinge
25730	22220/A		-	e			Pin for door
25735	80232		-	e			Reed magnet
25740	11721		-	e			Nut (minmum 10 pieces)
25745	90024		-	e			Slide for door
25750	11177		-	e			Ø6x12 Plain washer (minimum 10 pieces)
25755	11176		-	e			Ø 5 Plain washer (minimum 20 pieces)
25760	11169		-	e			M5 inox-nut (minmum 10 pieces)
25765	90916		-	e			Door movement support
25770	11815		-	e			Ø8 stainless steel snap ring (minimum 5 pieces)
25775	11104/B		-	e			M6x16 stainless steel screw (minimum 5 pieces)
25780	80750		-	e			Stainless steel handle

e=ELECTRONICAL SWITCHES, dc=DOUBLE BODY VERSION, uw=LOWER AND UPPER VERSION

82E=82E

bp=BOOSTER PUMP, dd=DETERGENT DISPENCER

A=3/N/PE~380-400V 50-60Hz, D=3/PE~200-210V 50-60Hz, F=2/PE~220-240V 50-60Hz, G=3/N/PE~415V 50-60Hz, H=3/PE~220-230V 50-60Hz, K=3/PE~380-400V 50-60Hz, L=3/PE~415V 50-60Hz, M=3/PE~440V 60Hz, P=1/N/PE~220-230V 50-60Hz, R=2/PE~220-240V 50-60Hz, U=1/N/PE~240V 50-60Hz, V=3/PE~240V 50-60Hz, W=1/N/PE~100-110V 50-60Hz

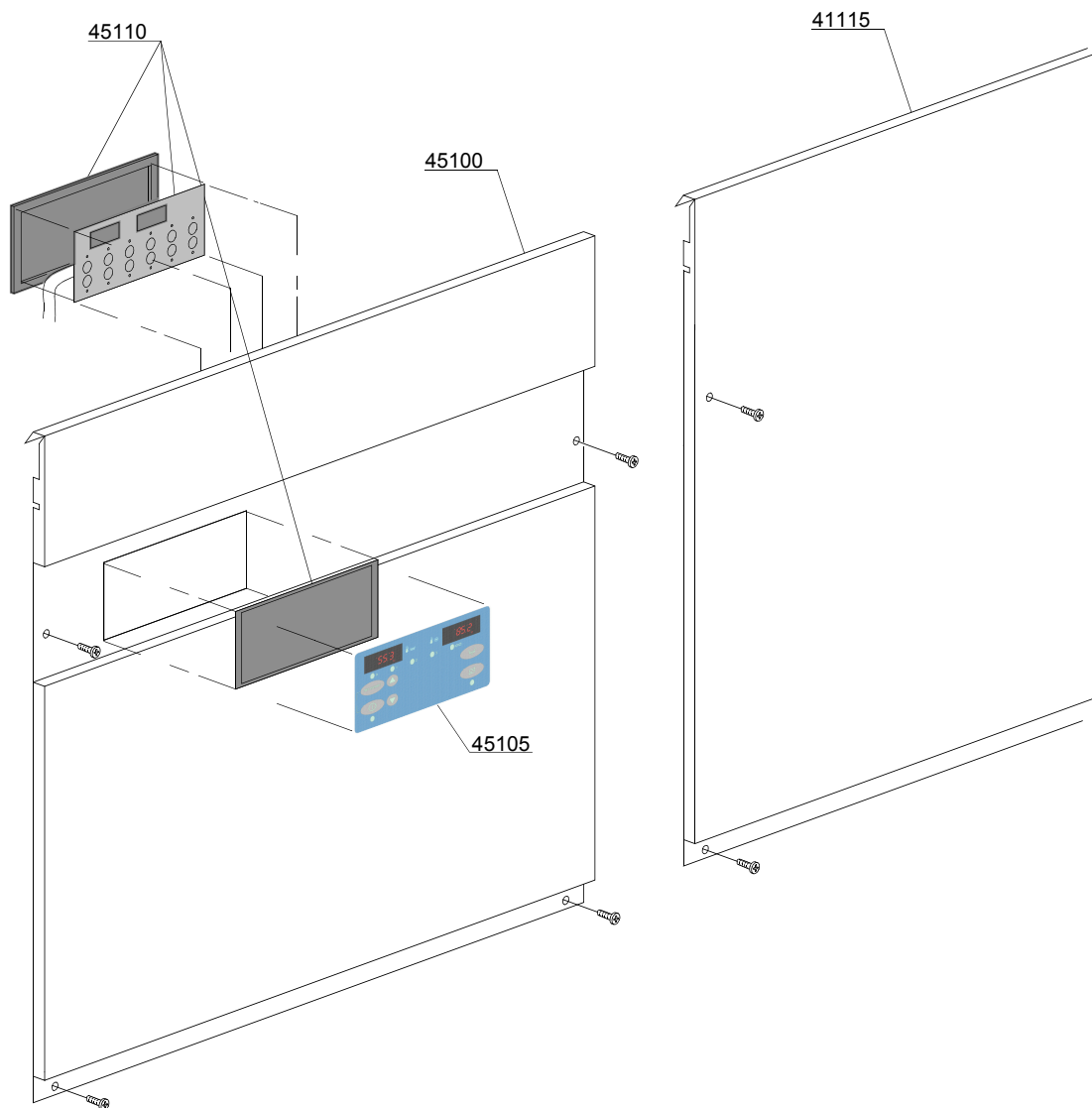

03_065_e

Spare parts

ID	P-code	SN from	SN to	Mod.	Acces.	Volt	Description
Module:Control panel and switches							
45100	93506		-	e			Left control panel
45105	50571		-	e			Silkscreen processed grill membrane push button-driver dp+ws(D)
45105	50575		-	e			Neutral silkscreen processed grill membrane push button-driver dp+ws(N)
45105	50578		-	e			Silkscreen processed grill membrane push button-driver dp+ws(K)
45110	50570/D		-	e			Compleat membrane push button-driver PLUS
45115	93507		-	e			Lateral right panel

e=ELECTRONICAL SWITCHES, dc=DOUBLE BODY VERSION, uw=LOWER AND UPPER VERSION

82E=82E

bp=BOOSTER PUMP, dd=DETERGENT DISPENCER

A=3/N/PE~380-400V 50-60Hz, D=3/PE~200-210V 50-60Hz, F=2/PE~220-240V 50-60Hz, G=3/N/PE~415V 50-60Hz, H=3/PE~220-230V 50-60Hz, K=3/PE~380-400V 50-60Hz, L=3/PE~415V 50-60Hz, M=3/PE~440V 60Hz, P=1/N/PE~220-230V 50-60Hz, R=2/PE~220-240V 50-60Hz, U=1/N/PE~240V 50-60Hz, V=3/PE~240V 50-60Hz, W=1/N/PE~100-110V 50-60Hz

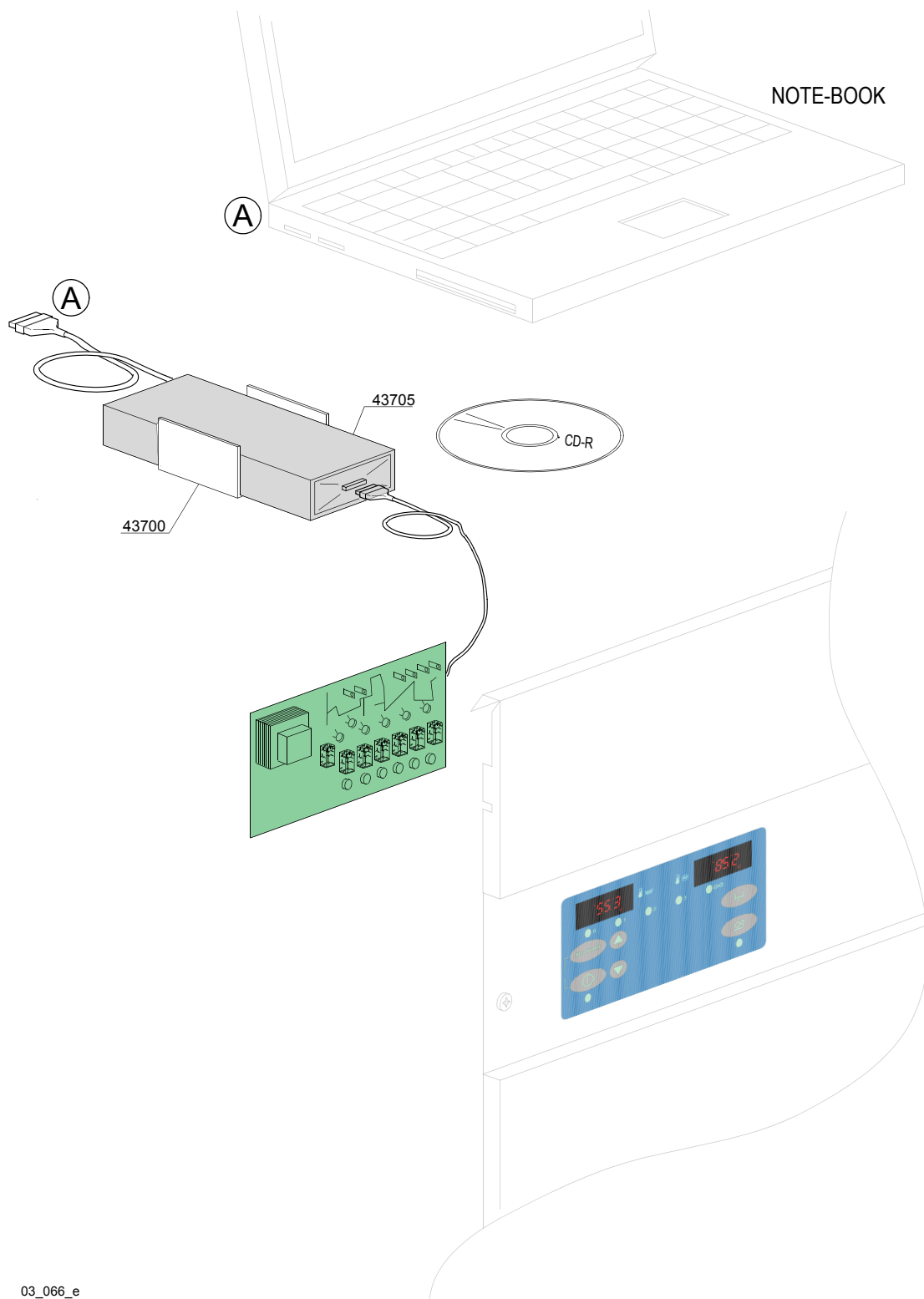

03_066_e

Spare parts

ID	P-code	SN from	SN to	Mod.	Acces.	Volt	Description
Module:Electronic control HACCP							
43700	3060200		-	e			Support DATA-LOGGER
43705	99910217		-	e			Kit remote control HACCP

e=ELECTRONICAL SWITCHES, dc=DOUBLE BODY VERSION, uw=LOWER AND UPPER VERSION

82E=82E

bp=BOOSTER PUMP, dd=DETERGENT DISPENSER

A=3/N/PE~380-400V 50-60Hz, D=3/PE~200-210V 50-60Hz, F=2/PE~220-240V 50-60Hz, G=3/N/PE~415V 50-60Hz, H=3/PE~220-230V 50-60Hz, K=3/PE~380-400V 50-60Hz, L=3/PE~415V 50-60Hz, M=3/PE~440V 60Hz, P=1/N/PE~220-230V 50-60Hz, R=2/PE~220-240V 50-60Hz, U=1/N/PE~240V 50-60Hz, V=3/PE~240V 50-60Hz, W=1/N/PE~100-110V 50-60Hz

04_039_e

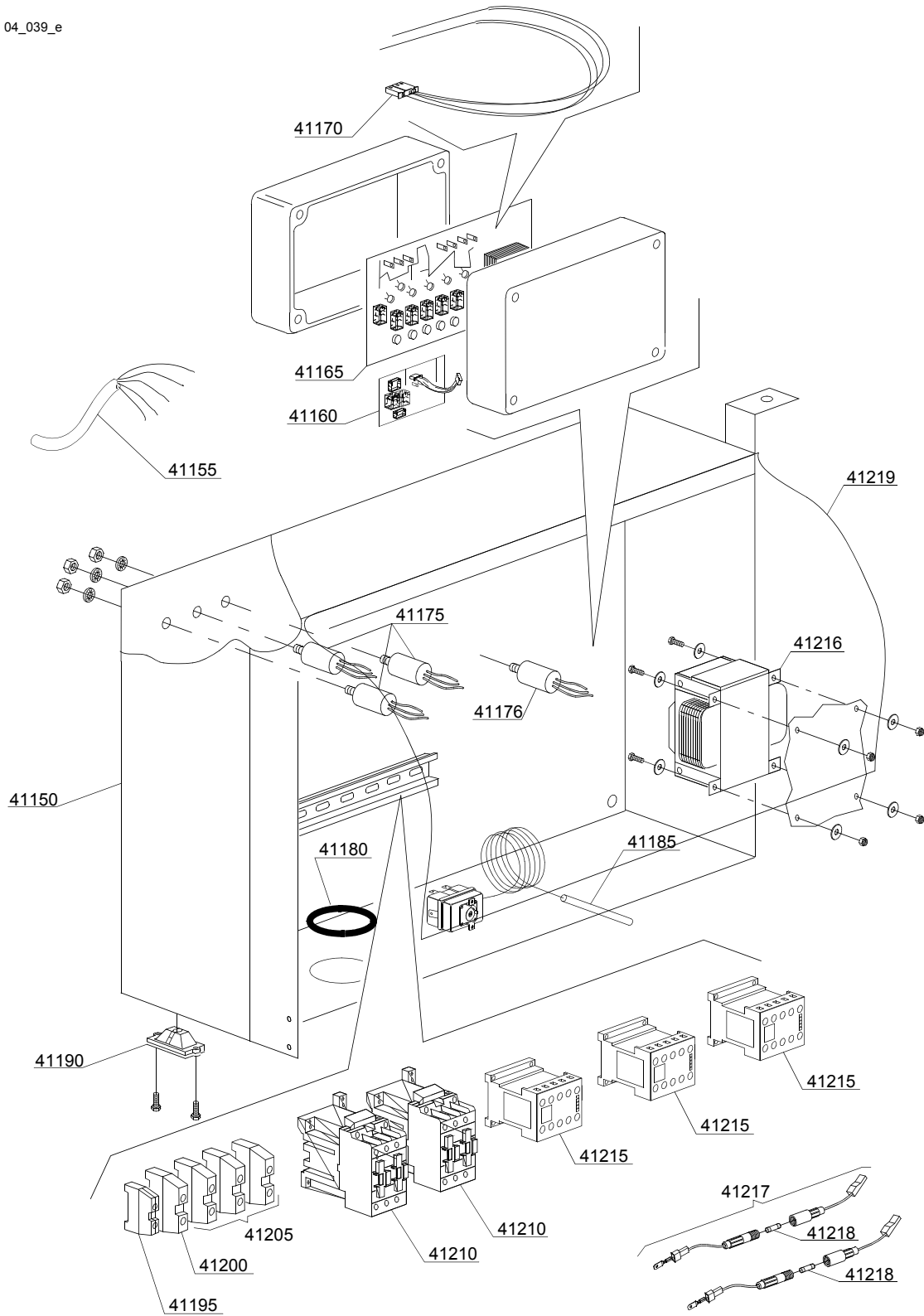

Spare parts

ID	P-code	SN from	SN to	Mod.	Acces.	Volt	Description
Module:Electric control components							
41150	91001		-	e			Electrical control panell
41155	80200		-	e		A,G	Power supply cable 5x4x3400
41155	75359		-	e		A,G	Power supply cable anti-flame 4x6x3400
41160	50559		-	e			Electronic Timer optional+On-Board EXP-PS
41165	50569		-	e			Fiche sans chip
41170	50562		-	e			DIHR ECO-2 Sensor
41175	15149		-	e		A,H,K,P	Filter F3 (0,33 mF)
41176	15187		-	e		A,H,K,P	Filter F3 440 VaC 3
41180	13324		-	e			Lead through rubber Ø46x50
41185	2000430		-	e		A,H,K,P	90/110 1500 PVC Thermostat
41190	15065/A		-	e			Cable press with lives
41195	10300401		-	e			6/8mm ² yellow/green terminal
41200	3006155		-	e			Blu neutral terminal
41205	3006082		-	e			Terminal 16mm ² SL-16
41210	10300050		-	e		A,F,H,K,P,R	Contacteur 25A/12A 4NA 230V
41215	15086		-	e			Contacteur 230 V
41216	15384		-	e			0-230V 160/230/400/415/440 Va Transformer
41217	3006147		-	e			5x10 Fuse holder
41218	15160		-	e			5x20 10A Fuse
41219	11600039		-	e			Transparent protection for members electrical workes

e=ELECTRONICAL SWITCHES, dc=DOUBLE BODY VERSION, uw=LOWER AND UPPER VERSION

82E=82E

bp=BOOSTER PUMP, dd=DETERGENT DISPENSER

A=3/N/PE~380-400V 50-60Hz, D=3/PE~200-210V 50-60Hz, F=2/PE~220-240V 50-60Hz, G=3/N/PE~415V 50-60Hz, H=3/PE~220-230V 50-60Hz, K=3/PE~380-400V 50-60Hz, L=3/PE~415V 50-60Hz, M=3/PE~440V 60Hz, P=1/N/PE~220-230V 50-60Hz, R=2/PE~220-240V 50-60Hz, U=1/N/PE~240V 50-60Hz, V=3/PE~240V 50-60Hz, W=1/N/PE~100-110V 50-60Hz

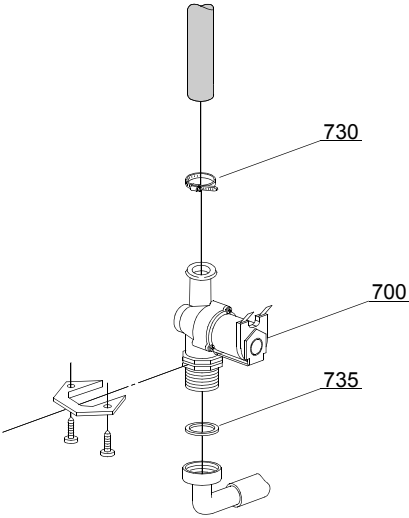

05_002_€

Spare parts

ID	P-code	SN from	SN to	Mod.	Acces.	Volt	Description
Module:Solenoid valve group							
700	10703		-	e,dc			Single solenoid valve - 230Vac
730	11807		-	e,dc			12/22 clamp (minimum 3 pieces)
735	13307		-	e,dc			3/4 gasket

e=ELECTRONICAL SWITCHES, dc=DOUBLE BODY VERSION, uw=LOWER AND UPPER VERSION

82E=82E

bp=BOOSTER PUMP, dd=DETERGENT DISPENSER

A=3/N/PE~380-400V 50-60Hz, D=3/PE~200-210V 50-60Hz, F=2/PE~220-240V 50-60Hz, G=3/N/PE~415V 50-60Hz, H=3/PE~220-230V 50-60Hz, K=3/PE~380-400V 50-60Hz, L=3/PE~415V 50-60Hz, M=3/PE~440V 60Hz, P=1/N/PE~220-230V 50-60Hz, R=2/PE~220-240V 50-60Hz, U=1/N/PE~240V 50-60Hz, V=3/PE~240V 50-60Hz, W=1/N/PE~100-110V 50-60Hz

06_008_e

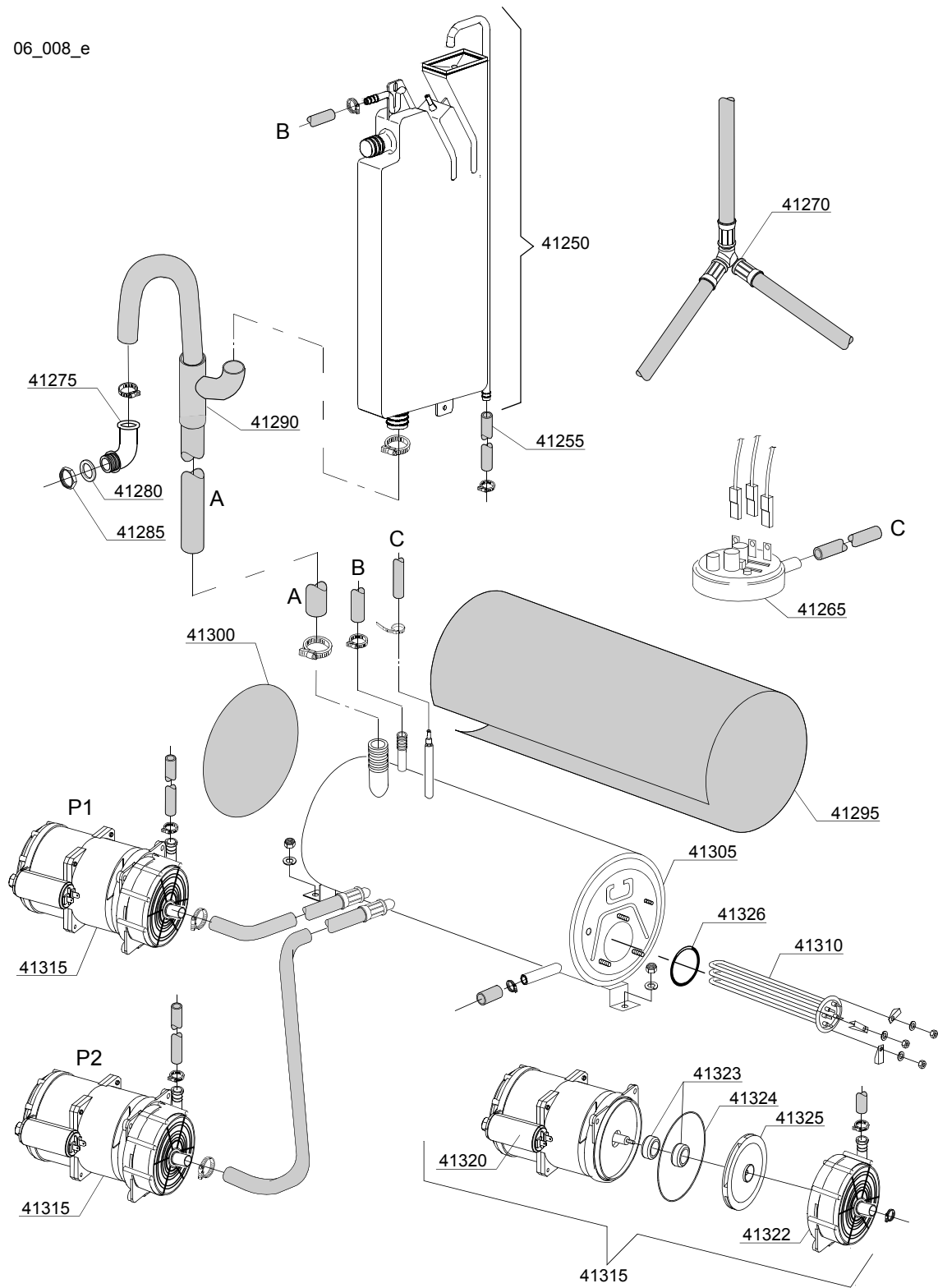

Spare parts

ID	P-code	SN from	SN to	Mod.	Acces.	Volt	Description
Module: Rinse with steady temperature							
41250	15720		-	e,dc			Break tank assembly
41255	2907352		-	e,dc			PVC WRAS rubber hose
41265	10706/A		-	e,dc			47-27 pressure switch
41270	91110		-	e,dc			Ø12 mm plastic 3 ways connection
41275	10701		-	e,dc			Drain elbow
41280	13305		-	e,dc			44x32x3 O-ring (minimum 5 pieces)
41285	11701/A		-	e,dc			Stainless steel nut
41290	91112		-	e,dc			Muff of emergency
41295	91116		-	e,dc			Insulation boiler 600x680
41300	91115		-	e,dc			Ø190x3 end piece
41305	91104		-	e,dc			Atmospheric Boiler AISI-316
41310	30001011		-	e,dc			Element 9,0 kW 230/240 VaC 3
41315	15100/D		-	e,dc			Rinsing pump / booster pump 220/240V
41320	10702		-	e,dc			5 uF condenser
41322	15100/V		-	e,dc			Scroll
41323	15100/S		-	e,dc			Rotating seals
41324	15100/T		-	e,dc			OR O-ring
41325	15100/U		-	e,dc			Pump rotor
41326	13015		-	e,dc			O-ring 6225 OR 160 NBR

e=ELECTRONICAL SWITCHES, dc=DOUBLE BODY VERSION, uw=LOWER AND UPPER VERSION

82E=82E

bp=BOOSTER PUMP, dd=DETERGENT DISPENSER

A=3/N/PE~380-400V 50-60Hz, D=3/PE~200-210V 50-60Hz, F=2/PE~220-240V 50-60Hz, G=3/N/PE~415V 50-60Hz, H=3/PE~220-230V 50-60Hz, K=3/PE~380-400V 50-60Hz, L=3/PE~415V 50-60Hz, M=3/PE~440V 60Hz, P=1/N/PE~220-230V 50-60Hz, R=2/PE~220-240V 50-60Hz, U=1/N/PE~240V 50-60Hz, V=3/PE~240V 50-60Hz, W=1/N/PE~100-110V 50-60Hz

10_001be

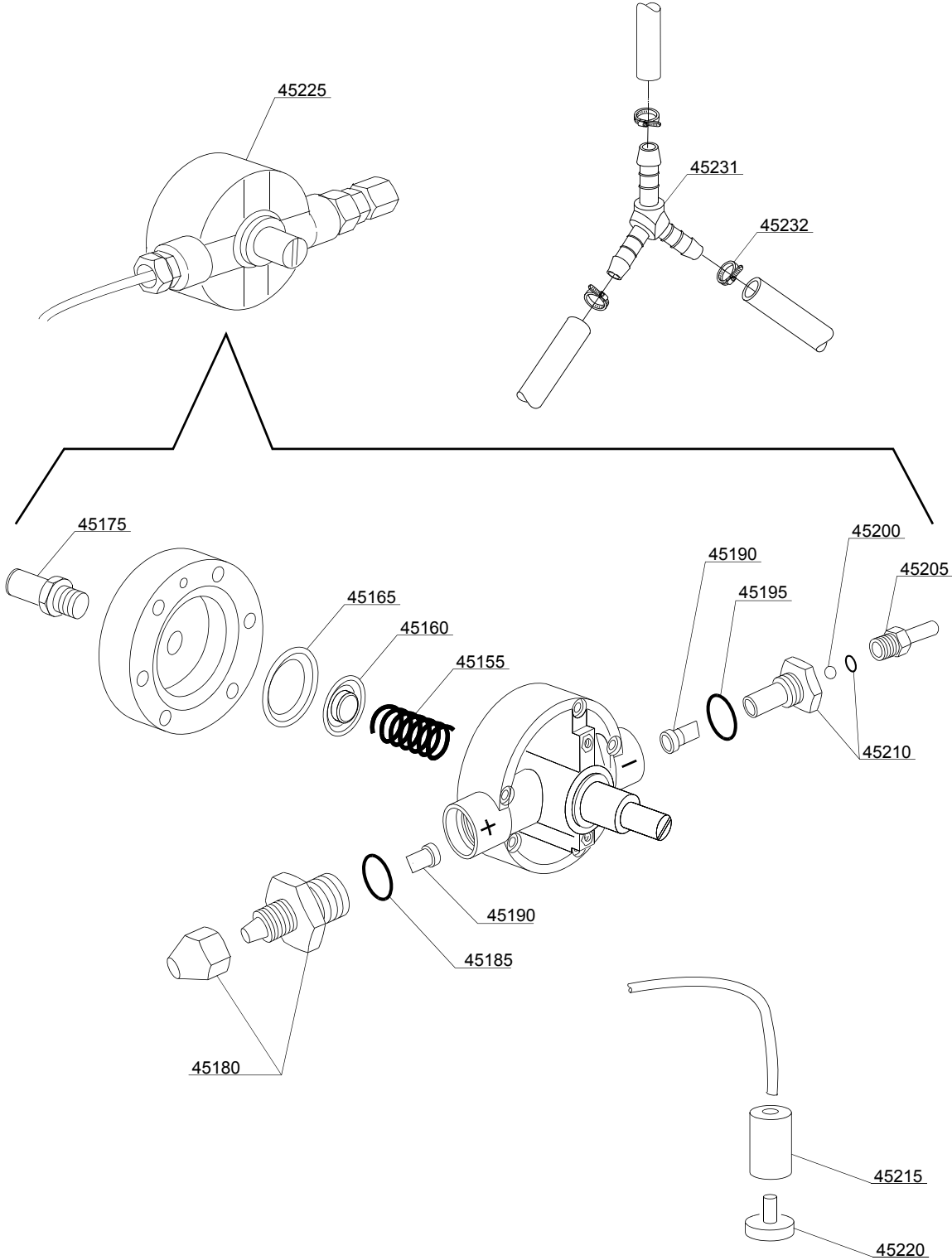

Spare parts

ID	P-code	SN from	SN to	Mod.	Acces.	Volt	Description
Module: Rinse aid dispenser group							
45155	10705/M		-	e,dc			Spring
45160	10705/N		-	e,dc			Disc to membrane
45165	10750/O		-	e,dc			Membrane
45175	12506		-	e,dc			Rubber-holder Ø 10mm
45180	10705/G		-	e,dc			Pipe fitting
45185	10705/C		-	e,dc			OR-gasket
45190	10705/D		-	e,dc			Silicone valve
45195	10705/C		-	e,dc			OR-gasket
45200	10705/T		-	e,dc			Sphere made of Teflon
45205	10705/R		-	e,dc			Brass pipe fitting
45210	10705/E		-	e,dc			OR-gasket Guide valve
45215	12525		-	e,dc			Ballast
45220	15058		-	e,dc			Small filter (minimum 3 pieces)
45225	10799/G		-	e,dc			GERMAC rinse aid dispenser
45231	540091		-	e,dc			Ø12 mm plastic 3 ways connection
45232	11807		-	e,dc			Clamp 12-22 (minimum 3 pieces)

e=ELECTRONICAL SWITCHES, dc=DOUBLE BODY VERSION, uw=LOWER AND UPPER VERSION

82E=82E

bp=BOOSTER PUMP, dd=DETERGENT DISPENSER

A=3/N/PE~380-400V 50-60Hz, D=3/PE~200-210V 50-60Hz, F=2/PE~220-240V 50-60Hz, G=3/N/PE~415V 50-60Hz, H=3/PE~220-230V 50-60Hz, K=3/PE~380-400V 50-60Hz, L=3/PE~415V 50-60Hz, M=3/PE~440V 60Hz, P=1/N/PE~220-230V 50-60Hz, R=2/PE~220-240V 50-60Hz, U=1/N/PE~240V 50-60Hz, V=3/PE~240V 50-60Hz, W=1/N/PE~100-110V 50-60Hz

Spare parts

ID	P-code	SN from	SN to	Mod.	Acces.	Volt	Description
Module: Wash pump							
41350	91106		-	uw			Top delivery pipe
41355	93604		-	uw			Left Wash ramp
41356	93603		-	uw			Right Wash ramp
41360	92102		-	uw			Low delivery pipe
41370	80912		-	uw			Pump 3,6-HP 220 / 380 50-Hz
41370	80912/E		-	uw			Pump 3,6-HP 220 / 380 60-Hz
41375	3002020		-	uw			Tank suction elbow
41380	90008		-	uw			Lower / Upper turret
41385	93508		-	uw			Pump support
41390	2902481		-	uw			60-80 clamp (minimum 2 pieces)
41395	11824		-	uw			50/70 clamp (minimum 2 pieces)
41400	11810		-	uw			40/60 clamp (minimum 2 pieces)
41401	92104		-	uw			Side inlet pipe
41402	2200103		-	uw			3/4 " Nut
41403	13326		-	uw			Gasket 38x27x2
41404	92106		-	uw			Fixation tube alimentation lateral
41405	13025		-	uw			O-ring 2081
41406	92105		-	uw			Tube lavage lateral
41407	2002051		-	uw			Gasket EPDM 17.5x1.5
41408	2002054		-	uw			Plug for arm
41409	93607		-	uw			60/63/56 Elbow
41410	80912/B		-	uw			Rotating seals
41411	80912/A		-	uw			Pump rotor HP-3,6 D100 (F2275)
41412	80912/D		-	uw			O-ring
41413	80912/C		-	uw			Scroll

e=ELECTRONICAL SWITCHES, dc=DOUBLE BODY VERSION, uw=LOWER AND UPPER VERSION
82E=82E

bp=BOOSTER PUMP, dd=DETERGENT DISPENSER

A=3/N/PE~380-400V 50-60Hz, D=3/PE~200-210V 50-60Hz, F=2/PE~220-240V 50-60Hz, G=3/N/PE~415V 50-60Hz,
H=3/PE~220-230V 50-60Hz, K=3/PE~380-400V 50-60Hz, L=3/PE~415V 50-60Hz, M=3/PE~440V 60Hz, P=1/N/PE~220-
230V 50-60Hz, R=2/PE~220-240V 50-60Hz, U=1/N/PE~240V 50-60Hz, V=3/PE~240V 50-60Hz, W=1/N/PE~100-110V
50-60Hz

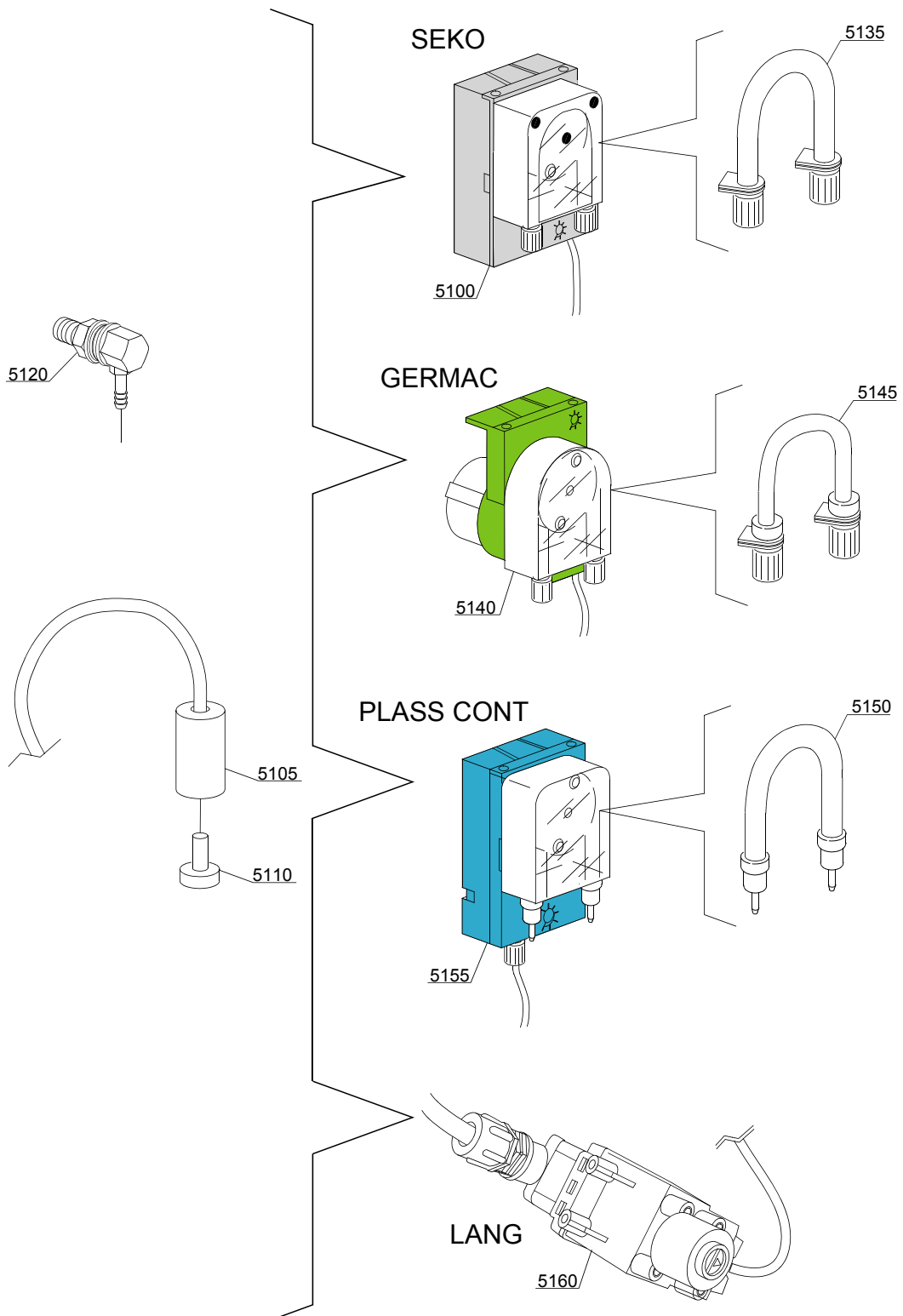

14_004_e

Spare parts

ID	P-code	SN from	SN to	Mod.	Acces.	Volt	Description
Module:Dosing detergent group							
5100	15985		-		dd		Seko detergent pump
5105	12525		-		dd		Counter-weight
5110	15058		-		dd		Suction filter (minimum 3 pieces)
5120	15123		-		dd		Steel injector
5125	15159		-		dd		OR O-ring (minimum 2 pieces)
5130	10200205		-		dd		Nut m12x1 (minimum 2 pieces)
5135	15185		-		dd		Ø 10 Seko thermoplastic pipe
5140	15985		-		dd		Germac detergent pump
5145	15108/E		-		dd		Ø 8 Germac thermoplastic pipe
5150	15985/A		-		dd		Ø 10 PLAS CONT thermoplastic pipe
5155	15985		-		dd		PLAS CONT detergent pump
5160	15108/L		-		dd		LANG detergent pump

e=ELECTRONICAL SWITCHES, dc=DOUBLE BODY VERSION, uw=LOWER AND UPPER VERSION

82E=82E

bp=BOOSTER PUMP, dd=DETERGENT DISPENSER

A=3/N/PE~380-400V 50-60Hz, D=3/PE~200-210V 50-60Hz, F=2/PE~220-240V 50-60Hz, G=3/N/PE~415V 50-60Hz, H=3/PE~220-230V 50-60Hz, K=3/PE~380-400V 50-60Hz, L=3/PE~415V 50-60Hz, M=3/PE~440V 60Hz, P=1/N/PE~220-230V 50-60Hz, R=2/PE~220-240V 50-60Hz, U=1/N/PE~240V 50-60Hz, V=3/PE~240V 50-60Hz, W=1/N/PE~100-110V 50-60Hz

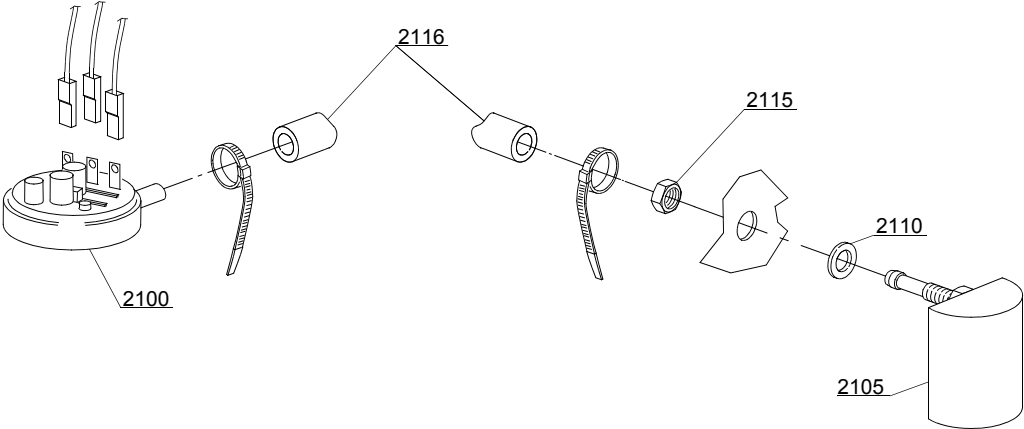

16_001_e

Spare parts

ID	P-code	SN from	SN to	Mod.	Acces.	Volt	Description
Module:Pressure switch group with air trap							
2100	88110		-	dc			Pressure switch
2105	135911		-	dc			Air trap
2110	13301		-	dc			Gasket 14x8x1,5 (minimum 10 pieces)
2115	11702		-	dc			Nut M8 (minimum 10 pieces)
2116	14508		-	dc			Pressure tube EPDM 4,5x9

e=ELECTRONICAL SWITCHES, dc=DOUBLE BODY VERSION, uw=LOWER AND UPPER VERSION

82E=82E

bp=BOOSTER PUMP, dd=DETERGENT DISPENSER

A=3/N/PE~380-400V 50-60Hz, D=3/PE~200-210V 50-60Hz, F=2/PE~220-240V 50-60Hz, G=3/N/PE~415V 50-60Hz, H=3/PE~220-230V 50-60Hz, K=3/PE~380-400V 50-60Hz, L=3/PE~415V 50-60Hz, M=3/PE~440V 60Hz, P=1/N/PE~220-230V 50-60Hz, R=2/PE~220-240V 50-60Hz, U=1/N/PE~240V 50-60Hz, V=3/PE~240V 50-60Hz, W=1/N/PE~100-110V 50-60Hz

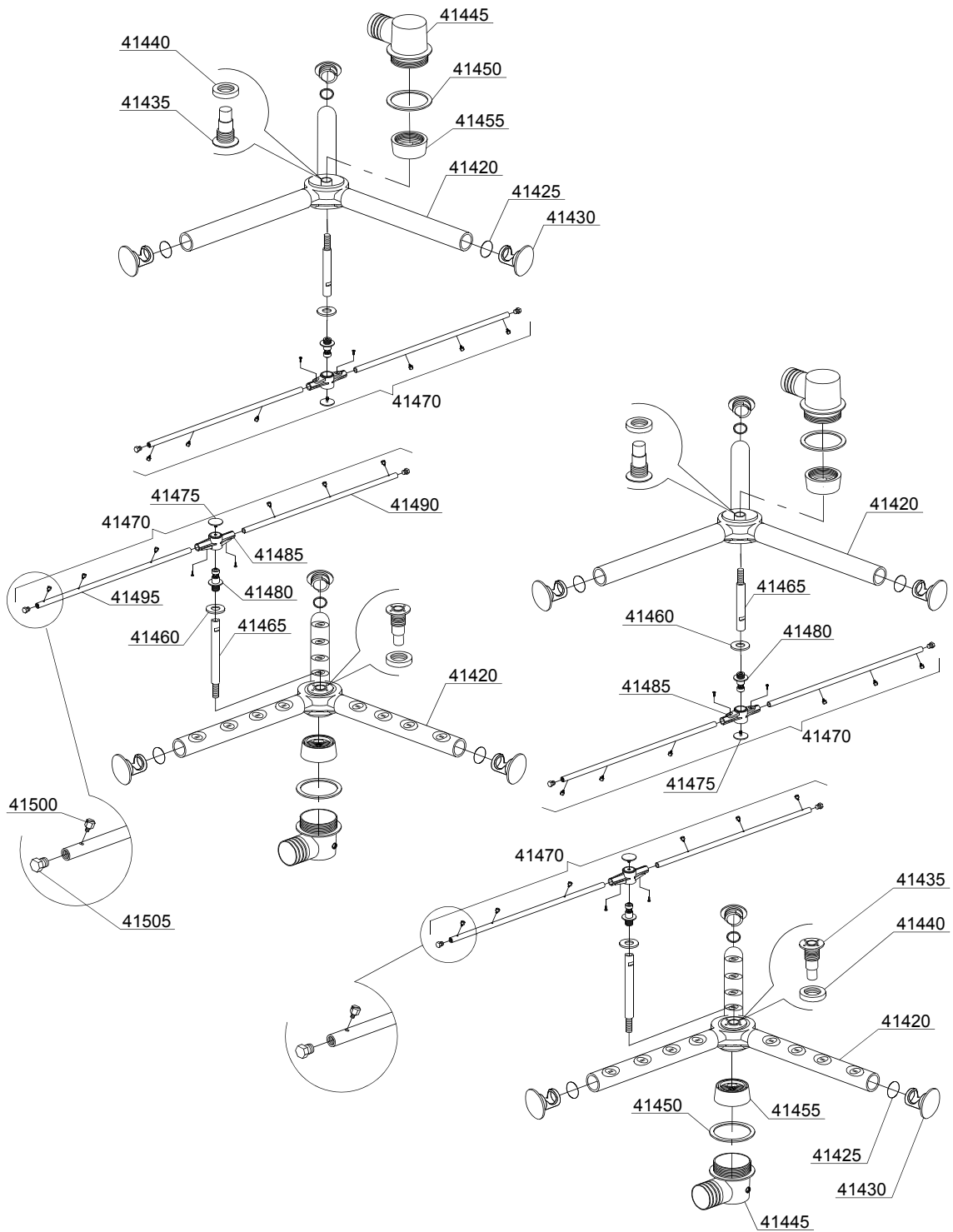

Spare parts

ID	P-code	SN from	SN to	Mod.	Acces.	Volt	Description
Module:Turret group with rotating arms							
41420	91102		-	uw			Upper/lower wash rotor
41425	13023		-	uw			OR 131 (4093) NBR O-ring (minimum 10 pieces)
41430	3003029		-	uw			Plug
41435	75316		-	uw			Hub for rotor
41440	75317		-	uw			Nut for wash arm bearing
41445	90008		-	uw			Lower turret
41450	80208		-	uw			OR 2050 NBR O-ring (minimum 40 pieces)
41455	90009		-	uw			Turret fixing hub
41460	90031		-	uw			Sliding washer (mat.ARNITE)
41465	90010		-	uw			Top rinse axle
41470	91103		-	uw			Top/lower rinse arm complete
41475	10652		-	uw			Stainless steel group fixing screw
41480	10651		-	uw			Rinse axle
41485	10650		-	uw			Rinse arm
41490	91103/D		-	uw			Right rinse arm - stainless steel nozzle
41495	91103/S		-	uw			Left rinse arm - stainless steel nozzle
41500	560018		-	uw			Stainless steel rinse nozzle
41505	560017		-	uw			Rinse arm plug

e=ELECTRONICAL SWITCHES, dc=DOUBLE BODY VERSION, uw=LOWER AND UPPER VERSION

82E=82E

bp=BOOSTER PUMP, dd=DETERGENT DISPENSER

A=3/N/PE~380-400V 50-60Hz, D=3/PE~200-210V 50-60Hz, F=2/PE~220-240V 50-60Hz, G=3/N/PE~415V 50-60Hz, H=3/PE~220-230V 50-60Hz, K=3/PE~380-400V 50-60Hz, L=3/PE~415V 50-60Hz, M=3/PE~440V 60Hz, P=1/N/PE~220-230V 50-60Hz, R=2/PE~220-240V 50-60Hz, U=1/N/PE~240V 50-60Hz, V=3/PE~240V 50-60Hz, W=1/N/PE~100-110V 50-60Hz