



I **STRUTTURA**
GB **STRUCTURE**

F **STRUCTURE**
D **STRUKTUR**

TAV. DATA - Gen.'99
01 REVISIONE - 01

POS.	CODICE MODELLO:				DESCRIZIONE	DESCRIPTION	DESCRIPTION	BESCHREIBUNG	Q.TY
	205	206	207	208					
01	210	210	210	210	Vite TC croce inoxM5x30	Stainless steel TC cross screw M5x30	Vis TC en croix inoxM5x30	Kreuzschlitzschraube TC aus EdelstahlM5x30	2
02	207510	207510	207510	208510	Pannello comandi	Command panel	Tableau des commandes	Bedienungmit Steuerungen	1
03	207500	207500	207500	208500	Copertura inox	Stainless steel cover	Couverture inox	Abdeckung aus Edelstahl	1
04	151	151	151	151	Rondella ZnM5	Zn washer, M5	Rondelle ZN M5	UnterlegscheibeM5 aus ZN	4
05	111	111	111	111	Dado Zn 5MA	Zn washer, 5MA	Ecrou ZN 5MA	Mutterschraube 5MA aus ZN	4
06	205520	205520	207520	208520	Schiena posteriore	Rear panel	Panneau arrière	Hintere Rückseite	1
07	205530	205530	207530	208530	Vasca	Tank	Cuve	Becken	1
08	221	221	221	221	Vite TE Zn M6x15	Zn TE screw,M6x15	Vis TE ZN M6x15	Schraube TE M6x15 aus ZN	4
09	161	161	161	161	Rondella ZnM6	Zn washer, M6	Rondelle ZN M6	UnterlegscheibeM6 aus ZN	4
10	207560	207560	207560	208560	Zoccolo inox	Stainless steel base	Socle inox	Sockel aus Edelstahl	1
11	207570	207570	207570	208570	Guida dx cesto quadro	Right-hand square basket guide	Guide droit panier carré	Rechte schiene quadratischer korb	1
12	3290	3290	3290	3290	Piedino regolabile	Adjustable foot	Pied réglable	Einstellbarer Fuß	4
13	110	110	110	110	Dado inox 5MA	Stainless steel nut, 5MA	Ecrou inox 5MA	Mutterschraube aus Edelstahl 5MA	2
14	160	160	160	160	Rondella inox M6	Stainless steel washer, M6	Rondelle inox M6	Unterlegscheibe aus Edelstahl M6	2
15	200	200	200	200	Vite TE inoxM5x12	Stainless steel TE screw M5x12	Vis TE inox M5x12	Schraube TE aus EdelstahlM5x12	2
16	4000	4000	4000	4000	Cerniera porta	Door hinge	Charnière porte	Scharnier Tür	1
17	4100	4100	4100	4100	Perno inox porta	Stainless steel door pin	Goujon inox porte	Zapfen Tür aus Edelstahl	1
18	220	220	220	220	Vite TC croce inoxM6x20	Stainless steel TC cross screw M6x20	Vis TC en croix inoxM6x20	Kreuzschlitzschraube TC aus EdelstahlM6x20	2
19	207550	207550	207550	208550	Frontale inox inferiore	Lower stainless steel front panel	Bandeau frontal inox inférieur	Untere Front aus Edelstahl	1
20	205540	205540	207540	208540	Porta	Door	Porte	Tür	1
21	1225	1225	1225	1225	Magnete portamicointerruttore	Microswitch holdingmagnet	Aimant portemicrocontact	Magnet Mikroschalter von Tür	1
22	207571	207571	207571	208571	Guida sx cesto quadro	Left-hand square basket guide	Guide gauche panier carré	Linke Schiene quadratischer Korb	1
23	207545	207545	207545	208545	Guarnizione labirinto	Labyrinth gasket	Joint labyrinthe	Labyrinthdichtung	1
24	1225	1225	1225	1225	Magnete portamicointerruttore	Microswitch holdingmagnet	Aimant portemicrocontact	Magnet Mikroschalter von Tür	1

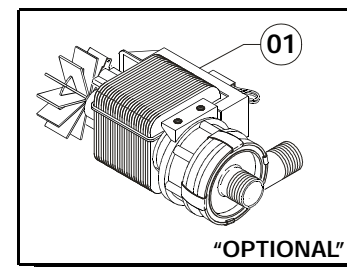
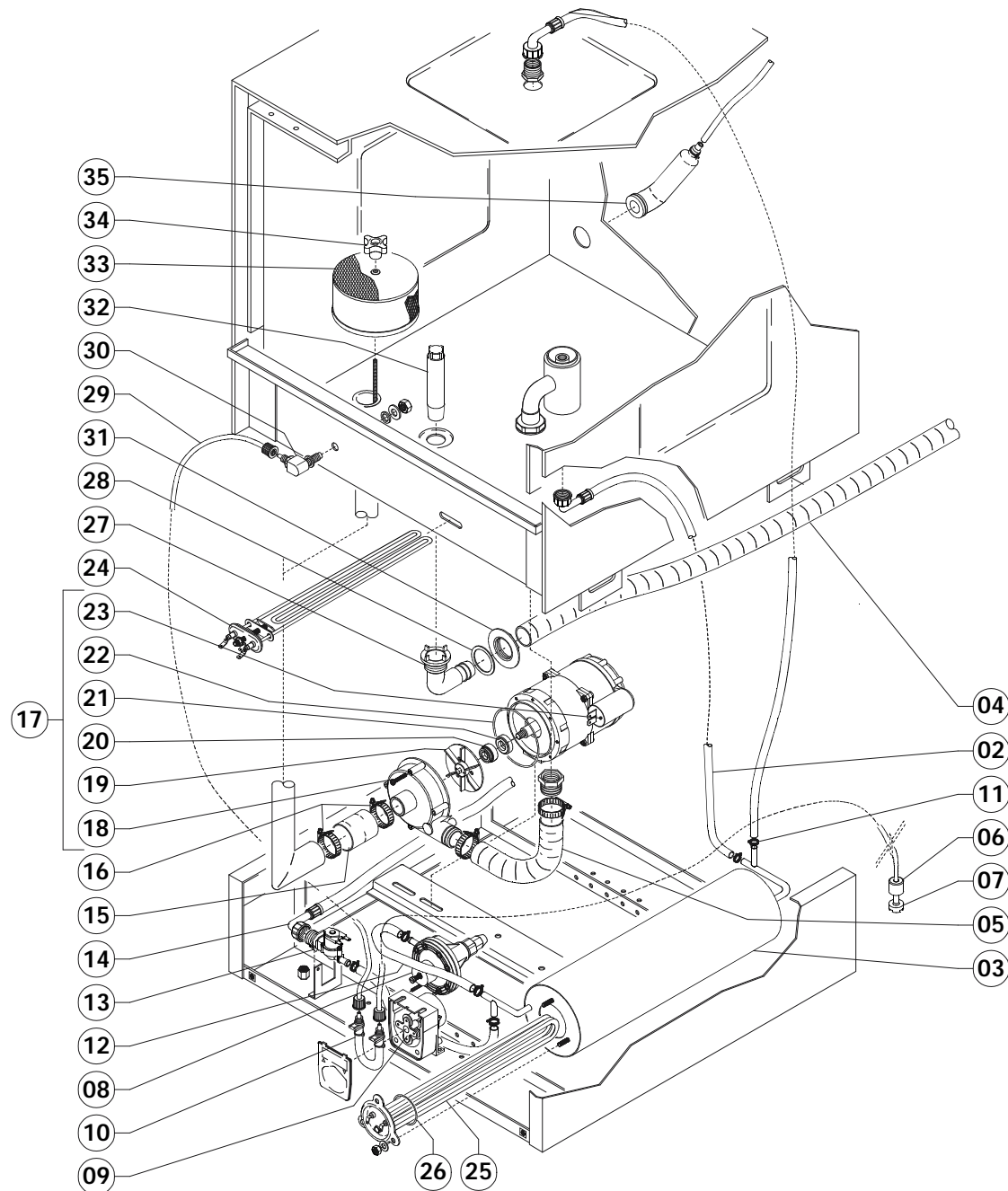



I GRUPPO POMPA
GB PUMP GROUP

F GROUPE POMPE
D PUMPENEINHEIT

TAV. DATA - Gen.'99
02 REVISIONE - 01

POS.	CODICE MODELLO:			DESCRIZIONE	DESCRIPTION	DESCRIPTION	BESCHREIBUNG	Q.TY
	205	207	208					
01	5100	5100	5100	Optional mot. pompa scarico 100W	Optional discharge pump motor, 100W	Optionmoteur pompe vidange 100 W	Optional Motor für Pumpe vom Abfluß 100 W	1
02	205725	207725	208725	Tubo gomma 90°C con raccordo da ¾G	90°C rubber tube with joint, ¾ G	Tuyau en caoutchouc 90°C avec raccord de ¾ G	Gummischlauch 90° mit Anschluß ¾ G Zoll	1
03	207420	207420	208420	Boiler inox	Stainless steel boiler	Chauffe-eau inox	Boiler aus Edelstahl	1
04	1315	1315	1315	Tubo di scarico ø25 mm	Discharge pipe, ø25 mm	Tuyau de vidange ø25 mm	Abflußschlauch ø25 mm	1
05	207705	207705	208705	Manicotto ø32 raccordo inf. a "L"	Lower joint coupling, ø32 mm	Manchon ø32 raccord inf.	Muffe ø32mmunterer Anschluß	1
06	1215	1215	1215	Peso per tubetto aspirazione	Weight for intake tube	Poids pour petit tuyau aspiration	Gewicht für Ansaugschlauch	1
07	1218	1218	1218	Filtro per tubetto aspirazione	Filter for intake tube	Filtre pour petit tuyau aspiration	Filter für Ansaugschlauch	1
08	1200	1200	1200	Dosatore di brillantante	Rinse doser	Doseur de liquide rinçage	Dosierer für Klarspüler	1
09	1210	1210	1210	Dosatore di detergente elettrico Regolabile	Adjustable electric detergent doser	Doseur détergent électrique réglable	Elektrischer, einstellbarer Dosierer für Spülmittel	1
10	1212	1212	1212	Tubetto in santoprene	Santoprene tube	Petit tuyau en santoprène	Kleiner Schlauch aus Santopren	1
11	500	500	500	Fascetta inox 10-20	Stainless steel band, 10-20	Collier inox 10-20	Schelle aus Edelstahl 10-20	10
12	1380	1380	1380	Tubo di gomma 10-19 90°C al mt	Rubber hose, 10-19 90°C per metre	Tuyau en caoutchouc 10-19 90°C aumètre	Gummischlauch 10-19 90°C, prolf. M	1
13	103370	103370	103370	Elettrovalvola	Solenoid valve	Electrovanne	Elektroventil	1
14	1300	1300	1300	Tubo carico acqua 1,5 mt	Water entry pipe, 1.5 m	Tuyau de remplissage eau de 1.5 m	Wasseransaugschlauch, 1.5 m lang	1
15	205700	207700	208700	Manicotto ingresso pompa	Pump entry coupling rubber hose	Manchon entrée pompe	Muffe Pumpeneingang	1
16	520	520	520	Fascetta inox 21-44	Stainless steel band, 21-44	Collier inox 21-44	Schelle aus Edelstahl 21-44	4
17	6000	6000	6000	Motore pompa lavaggio HP 0,25	Wash pumpmotor, 0.25 HP	Moteur pompe lavage HP 0,25	Motor Spülpumpe 0,25 PS	1
18	6010	6010	6010	Chiocciola motore pompa	Pumpmotorvolute	Vis sans finmoteur pompe	Spiralgehäuse Pumpenmotor	1
19	6011	6011	6011	Girante motore pompa	Pumpmotorrotor	Rouemoteur pompe	Lauftrad Pumpenmotor	1
20	6014	6014	6014	Guarnizione tenuta rotante	Rotary sealing gasket	Joint d'étanchéité rotatif	Dichtung Lauftrad	1
21	6013	6013	6013	Guarnizione tenuta ceramica	Ceramic sealing gasket	Joint d'étanchéité céramique	Keramikdichtung	1
22	6012	6012	6012	Guarniz. OR per chiocciola pompa	Pumpvolute OR gasket	Bague torique pour vis sans fin pompe	O-ring-dichtung für Spiralgehäuse Pumpe	1
23	6015	6015	6015	Condensatore motore	Motor capacitor	Condensateur moteur	Kondensator vom Motor	1
24	103400	103400	103400	Resistenza vasca 1800 W	Tank heater, 1800W	Résistance cuve 1800 W	Heizschlange Becken 1800 W	1
25	103410	103410	103410	Resistenza boiler 1800 W	Boiler heater, 1800W	Résistance chauffe-eau 1800 W	Heizschlange Boiler 1800 W	1
26	103415	103415	103415	Guarniz. OR per resist. con flangia	OR heater gasket with flange	Bague torique pour résistance avec bride	O-Ring-Dichtung für Heizschlange mit Flansch	1
27	1130	1130	1130	Gomito raccordo in plastica da 1"	Plastic elbow joint, 1"	Coude raccord en plastique de 1"	Kniestück Plastikanschluß 1" Zoll	1
28	1131	1131	1131	Guarnizione piana scarico 1"	Discharge gasket 1"	Bague vidange 1"	Dichtung Abfluß 1"	1
29	1410	1410	1410	Tubetto 6x4 mm trasparente	Transparent tube, 6x4 mm	Petit tuyau 6x4 mm transparent	Kleiner transpar. Schlauch 6x4 mm	1
30	1211	1211	1211	Raccordo completo iniettore vasca	Complete joint for tank injector	Raccord complet injecteur cuve	Kompletter Anschluß Einspritzdüse Becken	1
31	1132	1132	1132	Rosetta ottone 1"	Joint nut, 1"	Ecrou raccord 1"	Mutterschraube für Anschluß 1" Zoll	1
32	1123	1123	1123	Tubo troppo pieno ø25 mm	"Too full" pipe, ø25 mm	Tuyau trop-plein ø 25 mm	Überlaufschlauch ø22mm	1
33	3270	3270	3270	Filtro inox	Stainless steel filter	Filtre inox	Filter aus Edelstahl	1
34	3271	3271	3271	Nottolino 4 lobi per filtro	4-lobe pawl for filter	Cliquet 4 lobes pour filtre	Sperrzahn mit 4 Nasen für Filter	1
35	3280	3280	3280	Trappola d'aria	Air trap	Prise d'air	Luftfalle	1

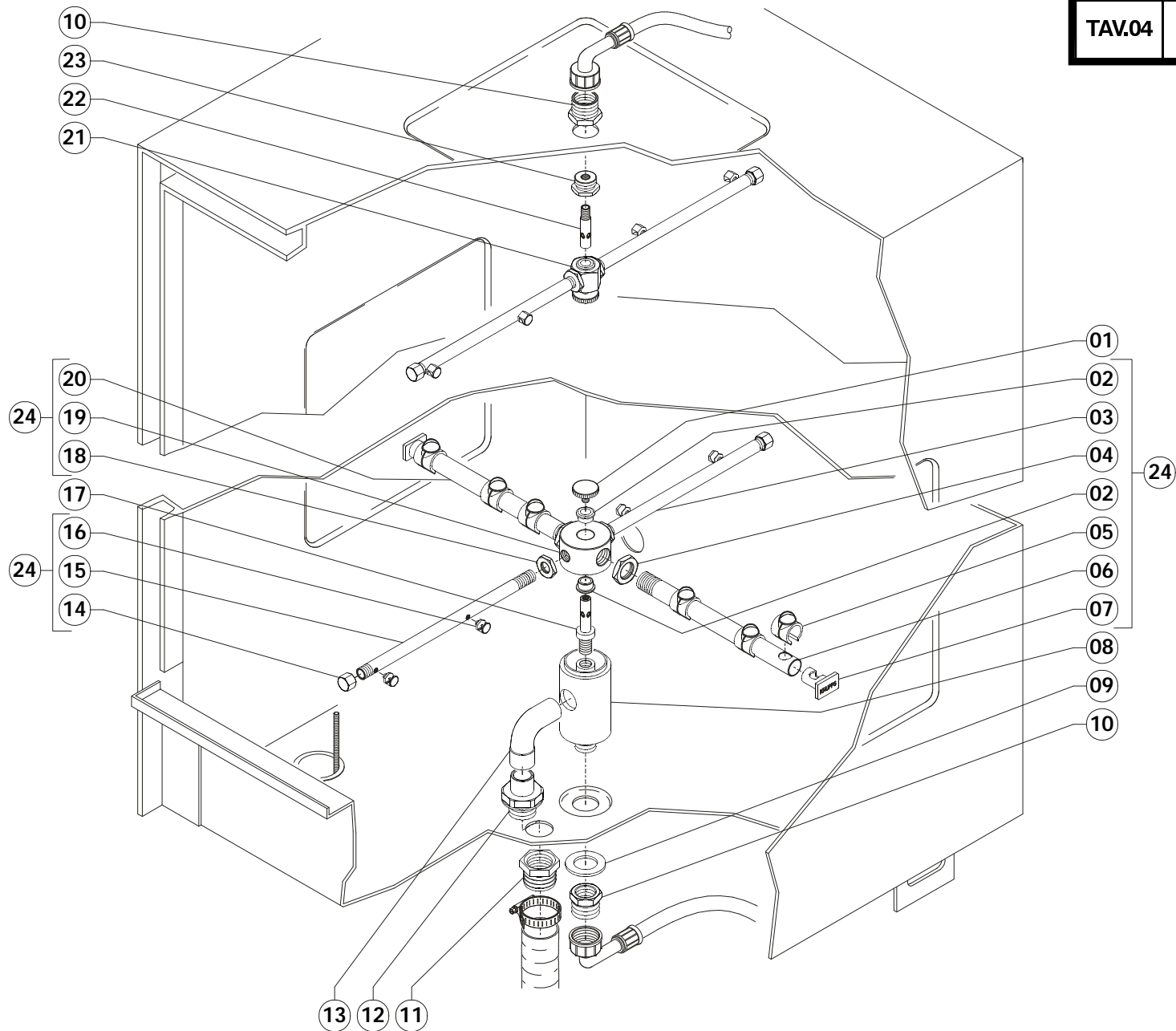



I
GB **GIRANTE
ROTOR**

F
D **ROUE
DREHARM**

TAV. DATA - Nov.'01
04 REVISIONE - 01

POS.	CODICE MODELLO: 205 - 207 208			DESCRIZIONE	DESCRIPTION	DESCRIPTION	BESCHREIBUNG	Q.TY
01	104040	104040	104040	Tappo inox zigrinato	Knurled stainless steel tap	Bouchon inox moleté	Gerändelter Deckel aus Edelstahl	2
02	104100	104100	104100	Bussola carbografite piccola ø14 mm	Small carbon-graphite bush, ø14 mm	Petite douille carbographe ø14 mm	Kleine Karbographitbuchse ø14 mm	4
03	207060	207060	208060	Tubo risciacquo inox dx completo	Complete right-hand stainless steel rinse pipe	Tuyau rinçage inox droit complet	Nachspülschlauch aus Edelstahl komplett für rechts	2
04	104080	104080	104080	Dado fissaggio tubo lav. ø18mm	Fixing nut for wash pipe, ø18 mm	Ecrou fixation tuyau lavant ø18mm	Mutterschraube zur Befestigung vom Spülschlauch ø18 mm	2
05	104020	104020	104020	Getto lavante in plastica	Plastic washing spout	Jet lavant en plastique	Spüldüse aus Plastik	6
06	207070	207070	208070	Tubo lavante inox dx completo	Complete right-hand stainless steel washing pipe	Tuyau lavant inox droit complet	Spülschlauch aus Edelstahl komplett für rechts	1
07	104030	104030	104030	Tappo lavante in plastica	Plastic washing tap	Bouchon lavant en plastique	Spüldeckel aus Plastik	2
08	104120	104120	104120	Corpo fisso centrale ø50 mm	Central fixed body, ø50 mm	Corps fixe central ø50 mm	Zentrales fixes Gehäuse ø50mm Zn	1
09	104230	104230	104230	Rondella M22 Zn	Zn washer, M22	Rondelle M22 ZN	Unterlegscheibe M22 aus Zn	1
10	104221	104221	104221	Riduzione ottone da ½G a ¾G	Reduction, from ½G to ¾G	Réduction de ½G à ¾G	Adapterstück aus von ½G auf ¾G Zoll	2
11	104200	104200	104200	Racc. portagomma lavante ø32 mm 3/4G/F	Wash pipe holding joint, ø32 mm 3/4G/F	Raccord porte tuyau lavant ø32 mm 3/4F	Anschluß Halterung Spülschlauch ø32 mm ¾G/F	1
12	104181	104181	104181	Codolo raccordo in inox ¾G	Inox shaft joint, ¾G	Extrémité raccord en inox ¾G	Inoxendstück für Anschluß ¾G Zoll	1
13	104170	104170	104170	Curva 90°C M/F per corpo ø50mm	M/F bend for body, ø50 mm	Coude 90° M/F pour corps ø50 mm	90°-Kurve mit beidseitigem M/F Innengewinde für Gehäuse ø50mm	1
14	104010	104010	104010	Tappo tubo risciacquo passo 12x1	Rinsing pipe tap, step 12x1	Bouchon tuyau rinçage pas 12x1	Deckel Nachspülschlauch Größe 12x1	4
15	207061	207061	208061	Tubo di risciacquo inox sx completo	Complete left-hand stainless steel rinsing pipe	Tuyau de rinçage inox gauche complet	Nachspülschlauch aus Edelstahl komplett für links	2
16	104000	104000	104000	Getto di risciacquo in ottone	Brass rinsing spout	Jet de rinçage en laiton	Nachspüldüse aus Messing	8
17	104060	104060	104060	Perno inox con filetto M12x0,75	Threaded stainless steel pin, M12x0.75	Goujon inox avec filet M12x0,75	Gewindestift aus Edelstahl M12x0,75	1
18	104090	104090	104090	Dado fissaggio tubo risciacquo ø12mm	Nut for fixing rinsing pipe ø12 mm	Ecrou de fixation tuyau de rinçage ø12 mm	Mutterschraube zur Befestigung vom Nachspülschlauch ø12 mm	4
19	104130	104130	104130	Testa girante ø50mm	Rotor head, ø50 mm	Tête roue ø50 mm	Kopf Dreharm ø50 mm	1
20	207071	207071	208071	Tubo lavante inox sx completo	Complete left-hand stainless steel washing pipe	Tuyau lavant inox gauche complet	Spülschlauch aus Edelstahl komplett für links	1
21	207800	207800	208800	Girante risciacquo completa di bussole	Rinse rotor complete with bushes	Roue rinçage munie de douilles	Dreharm Nachspülen komplett mit Buchsen	1
22	104065	104065	104065	Perno inox filettato per risciacquo M10x1	Threaded stainless steel pin for rinse, M10x1	Goujon inox fileté pour rinçage M10x1	Gewindestift aus Edelstahl M10x1 für Nachspülen	1
23	104255	104255	104255	Riduzione risciacquo in ottone da ½G a M10x1	Brass rinse reduction, ½G to M10x1	Réduction rinçage en laiton de ½G à M10x1	Adapterstück M10x1 aus Messing ½G für Nachspülen	1
24	207850	207850	208850	Girante di lavaggio e risciacquo completa di bussole	Wash and rinse rotor complete with bushes	Roue lavage et rinçage avec douille	Dreharm Spülen und Nachspülen komplett mit Buchsen	1

