

TAV.242		Struttura	Structure	Structure	Struktur	FEC065/FEMD065-066	FGC065/FGMD065-066
	Codice	Denominazione	Denominaton	Denominaton	Bezeichnung		
1	GAFOC00155	Porta forno	Porte du four	Oven door	Ofentür	x	x
2	GAFOC00030	Cerniera superiore porta	Charnière supérieure	Upper door hinge	Linke Türangel	x	x
3	GAFOC00157	Cerniera inferiore porta	Charnière inférieure	Lower door hinge	Untere Türangel	x	x
4	MPGOM03P00	Guarnizione vetro porta	Guarniture verre porte	Oven door glass gasket	Türdichtung	x	x
5	RTBF800021	Gommino porta	Bouchon en caoutchouc	Rubber cap	Türgummi	x	x
6	RTFOC00008	Cristallo porta forno	Verre porte four	Oven door glass	Ofentürglas	x	x
7	GAFOC00166	Controporta forno	Contre porte du four	Oven counter door	Gegentür	x	x
8	GAFOC00164	Cassetto	Tiroir	Drawer	Kasten	x	x
9	RTFOC00414	Guarnizione porta forno	Garniture porte du four	Oven door gasket	Türdichtung	x	x
10	PAFOC00329	Disco copriforo	Disque	Disk	Scheibe	x	x
11	PAFOC00410	Cruscotto	Panneau de contrôle	Control panel	Stirnbrett	x	x
12	RTFOC00413	Piedino inox	Pied inox	Inox foot	Inox-Fuß	x	x
13	PAFOC00416	Fianco destro	Côté droite	Right side	Rechte Seite	x	x
14	GAFOC00163	Coperchio	Couvercle	Cover	Topfdeckel	x	
14	GAFOC00159	Coperchio	Couvercle	Cover	Topfdeckel		x
15	PAFOC00410	Cruscotto	Panneau de contrôle	Control panel	Stirnbrett	x	x
16	PAFOC00418	Fianco sinistro	Côté gauche	Left side	Linke Seite	x	x
17	PAFOC00329	Disco scarico condensa	Disque évacuation condensation	Moisture drain dik	Scheibe	x	x
18	MPGOM03P00	Guarnizione	Garniture	Gasket	Dichtung	x	x
19	RTFOC00415	Asta trasversale scarico condensa	Antenne transversale évacuation cond.	Transverse rod moisture drain	Querstange	x	x
20	RTFOC00412	Asta anteriore scarico coindensa	Antenne avant évacuation cond.	Front rod moisture drain	Vordere Stange	x	x
21	RTFOC00392	Manopola scarico condens	Manette évacuation cond.	Moisture drain knob	Drehknopf Kondenswasserablass	x	x
22	RTFOC00403	Serratura porta forno	Serrure porte four	Oven door lock	Ofentürschloß	x	x
23	RTFOC00454	Distanziale serratura	Entretoise serrure	Lock spacer	Abstandstück	x	x
24	PAFOC00411	Supporto serratura	Support serrure	Lock support	Halterungschloß	x	x
25	RTFOC00035	Microinterruttore	Microswitch	Microswitch	Microswitch	x	x
26	RTFOC00036	Portalampada	Douille	Lamp-holder	Leuchtenhalterung	x	x
27	RTFOC00037	Lampada 25 W 230 V	Ampoule 25W 230V	Lamp 25W 230V	Leuchte 25W 230V	x	x
28	RTFOC00201	Vetro portalampada	Verre protège ampoule	Lamp-holder glass	Leuchtenhalterungsglass	x	x
29	RTFOC00202	Guarnizione portalampada	Garniture douille	Lamp-holder gasket	Dichtung	x	x
30	AFC0000090	Camino antivento	Cheminée antirefuleur	Chimney	Schornstein	x	x

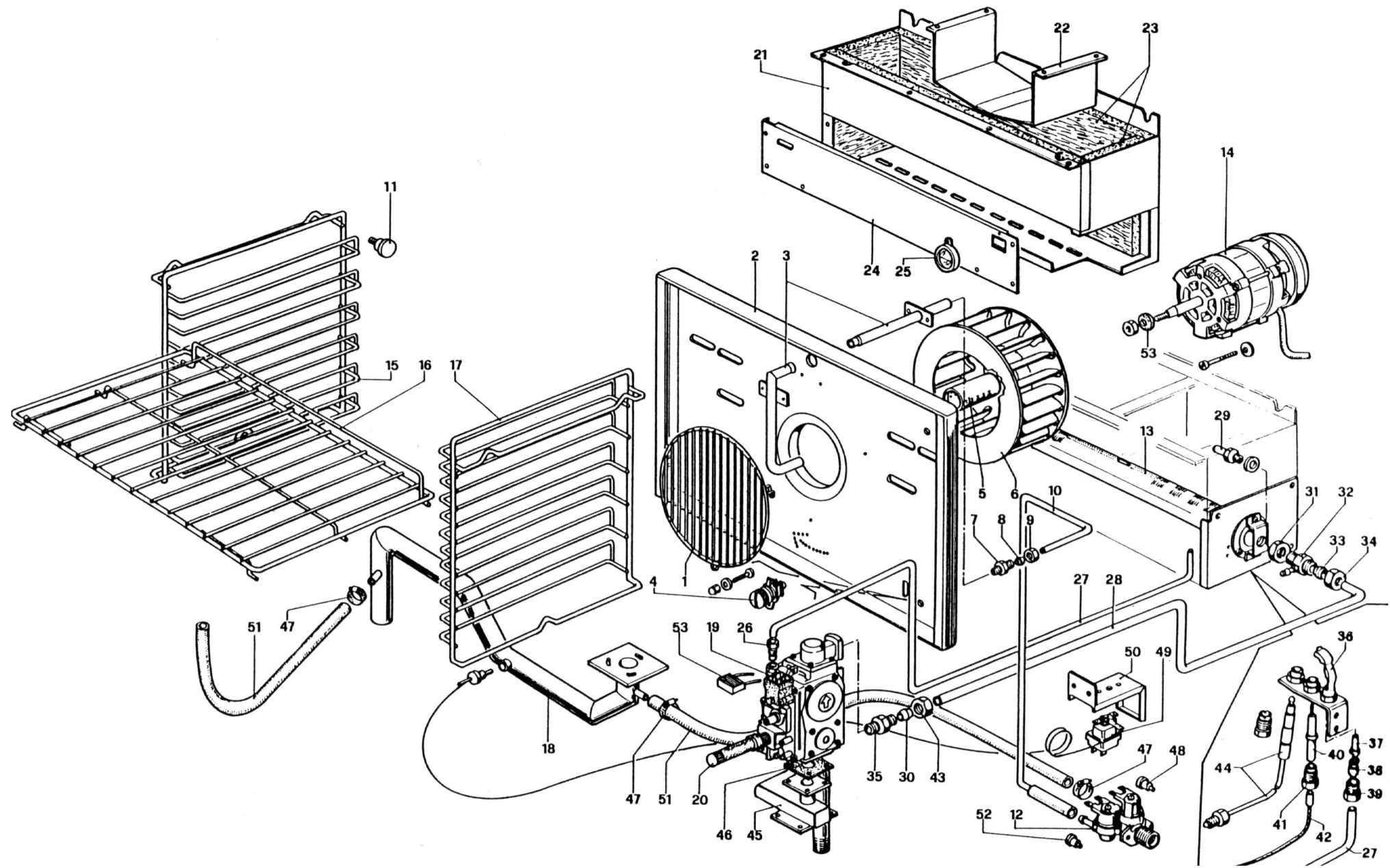

TAV.246		Griglie e impianto gas	Grilles et installation gaz	Grilles and gas system	Gitter und Gasanlage	FGC065	FGMD065/066
	Codice	Denominazione	Denominaton	Denominaton	Bezeichnung		
1	RTFOC00174	Griglia protezione ventilatore	Grille ventilateur	Fan grille	Ventilatorgitter	x	x
2	GAFOC00020	Convogliatore aria	Coiffe ventilateur air	Air duct	Luftförderer	x	x
3	RTFOC00408	Umidificatore	Humidificateur	Humidifier	Befeuchter	x	x
4	RTFOC00334	Attacco rapido	Attaque rapide	Quick connection	Schluss	x	x
5	RTFOC00155	Nebulizzatore	Nébulisateur	Atomizer	Zersträuber	x	x
6	RTFOC00012	Girante ventilatore	Couronne mobile ventilateur	Fan wheel	Ventilatorlau frad	x	x
7	RTFOC00019	Iniettore umidificatore	Injecteur humidificateur	Injecteur for humidifier	Einspritzer für Befeuchter	x	x
8	RTCU800183	Bicone Ø 6	Bicone pour tube Ø 6	Bicone for pipe Ø 6	Zweikegel Ø 6	x	x
9	RTFOC00020	Calotta per tubo Ø 6	Ecrou por tube Ø 6	Nut for pipe Ø 6	Mutter für Schlauch Ø 6	x	x
10	RTFOC00409	Tubo alimentazione umidificatore	Tube alimentation	Feeding pipe	Versorgungsrohr	x	x
11	RTCU700002	Attacco griglia laterale	Attaque latérale	Lateral connection	Seitenanschluß	x	x
12	RTFOC00203	Elettrovalvola 2 vie	Electrovanne 2 voies	Solenoid valve two ways	E-Ventil	x	x
13	GAFOC00064	Brucciatore	Brûleur	Burner	Brenner	x	x
14	RTFOC00011	Motore elettrico	Moteur électrique	Electric motor	E-Motor	x	x
15	RTFOC00417	Griglia laterale sinistra	Grille latérale gauche	Left lateral grate	Linker Seitenrost		x
15	RTFOC00425	Griglia laterale sinistra	Grille latérale gauche	Left lateral grate	Linker Seitenrost	x	
16	RTFOC00175	Griglia forno	Grille du four	Oven grate	Ofenrost		x
16	RTFOC00017	Griglia forno	Grille du four	Oven grate	Ofenrost	x	
17	RTFOC00416	Griglia laterale destra	Grille latérale droite	Right lateral grate	Rechter Seitenrost		x
17	RTFOC00424	Griglia laterale destra	Grille latérale droite	Right lateral grate	Rechter Seitenrost	x	
18	RTFOC00410	Rampa scarico condensa	Rampe evacuation condensation	Moisture drain ramp	Kondenswasserablassrampe	x	x
19	RTFOC00095	Valvola gas	Valve gas	Valve sit	Gasventil	x	x
20	RTFOC00391	Prolunga valvola gas	Prolongateur valve	Valve sit extension	Verlängerung	x	x
21	GAFOC00063	Camera di combustione	Chambre de combustion	Combustion chamber	Brennkammer	x	x
22	PAFOC00104	Deflettore bruciatore	Défecteur pour brûleur	Burner deflector	Deflektor	x	x
23	MPIS000012	Pannello isolante	Panneau isolant	Insulating panel	Isolier tafel	x	x
24	PAFOC00101	Coperchio camera combustione	Panneau antérieur chambre comb.	Combustion chamber face	Brennkammerforderwand	x	x
25	RTBF900054	Visore con retro	Doville	Viewer	Monitor	x	x
26	RTCU900217	Raccordo e bicone Ø 6	Ecrou et bicone Ø 6	Nut and bicone Ø 6	Mutter und Zweikegel Ø 6	x	x
27	RTFOC00423	Tubo alimentazione pilota	Tube pour veilleuse	Pilot pipe	Pilotbrennerrohr	x	x
28	RTFOC00422	Tubo alimentazione bruciatore	Tube alimentation brûleur	Burner feeding pipe	Brennerversorgungsrohr	x	x
29	RTCP800016	Iniettore Ø 1.70 per GPL	Injecteur Ø 1.70 pour GPL	Injector LPG Ø 1.70	Flüssiggas-Einspritzer Ø 1.70	x	x
29	RTFOC00278	Iniettore Ø 2,70 gas metano	Injecteur Ø 2.70 pour méthane	Methane injector Ø 2.70	Methangas-Einspritzer Ø 2.70	x	x
30	RTCP900088	Bicone Ø 14	Bicone Ø 14	Bicone Ø 14	Zweikegel Ø 14	x	x
31	RTCP800013	Controdado 1/2"	Countre écron 1/2"	Lock nut 1/2"	Gegenmutter 1/2"	x	x
32	RTCP800012	Supporto iniettore	Support injecteur	Injector support	Einspritzhalterung	x	x
33	RTBF800137	Bicone Ø 14	Bicone Ø 14	Bicone Ø 14	Zweikegel Ø 14	x	x
34	RTBF800015	Calotta Ø 14	Ecrou pour tube Ø 14	Nut for pipe Ø 14	Mutter für Schlauch Ø 14	x	x
35	RTCP900087	Niples 1/2"-M20	Niples 1/2"-M20	Niples 1/2"-M20	Nippel 1/2"-M20	x	x
36	RTCP800034	Corpo pilota	Corps veilleuse	Pilot body	Pilotbrenner	x	x
37	RTCP800041	Iniettore pilota Ø 0,19 per GPL	Injecteur veilleuse Ø 0.19 pour GPL	LPG pilot injecteur Ø 0.19	Flüssiggas-Einspritzer Ø 0.19	x	x
37	RTCP800040	Iniettore Ø 0.36 gas metano	Injecteur veilleuse Ø 0.36 pour méthane	Methane pilot injecteur Ø0.36	Methangas-Einspritzer Ø 0.36	x	x
38	RTCU800183	Bicone Ø 6	Bicone Ø 6	Bicone Ø 6	Zweikegel Ø 6	x	x
39	RTCU800182	Calotta Ø 6	Ecrou pour tube Ø 6	Nut for pipe Ø 6	Mutter für Schlauch Ø 6	x	x

TAV.246		Griglie e impianto gas	Grilles et installation gaz	Grilles and gas system	Gitter und Gasanlage	FGC065	FGMD065/066
	Codice	Denominazione	Denominaton	Denominaton	Bezeichnung		
40	RTCP800033	Candela rotonda	Bugie d'allumage	Spark plug	Zündkerze	x	x
41	RTCU900215	Raccordo candela pilota	Raccord pour bugie veilleuse	Fitting for pilot spark plug	Anschlußstück	x	x
42	RTFOC00128	Cavo accensione	Cable d'allumage	Lighting cable	Zündkabel	x	x
43	RTCP900089	Calotta Ø 14	Ecrou pour tube Ø 14	Nut for pipe Ø 14	Mutter für schlauch Ø 14	x	x
44	RTFOC00241	Termocoppia 100cm	Thermocouple 100cm	Thermocouple 100cm	Thermoelement 100cm	x	x
45	RTFOC00327	Rampa forno	Collecteur du four	Oven collector	Speiserampe	x	x
46	RTFOC00100	Guarnizione rampa	Garniture	Gasket	Dichtung	x	x
47	RTMIN00221	Fascetta Ø 14-22	Collier Ø 14-22	Clamp Ø 14-22	Windel Ø 14-22	x	x
48	RTFOC00120	Regolatore elettrovalvola Ø 0,25	Regulateur electrovanne Ø 0,25	Solenoid valve regulator Ø 0,25	E-Ventil Regler Ø 0,25	x	x
49	RTFOC00275	Termostato elettrico	Thermostat	Thermostat	Thermostat	x	x
50	PACP800062	Squadretta portatermostato	Egierre de fixation therm.	Bracket to fix thermostat	Winkel	x	x
51	MPGOM10T00	Tubo gomma Ø 10x17	Tuyau Ø 10x17	Pipe Ø 10x17	Rohr Ø 10x17	x	x
52	RTFOC00145	Regolatore elettrovalvola Ø 1,2	Regulateur electrovanne Ø 1,2	Solenoid valve regulator Ø 1,2	E-Ventil Regler Ø 1,2	x	x
53	RTFOC00302	Anello tenuta albero motore	Garniture	Gasket	Dichtung	x	x

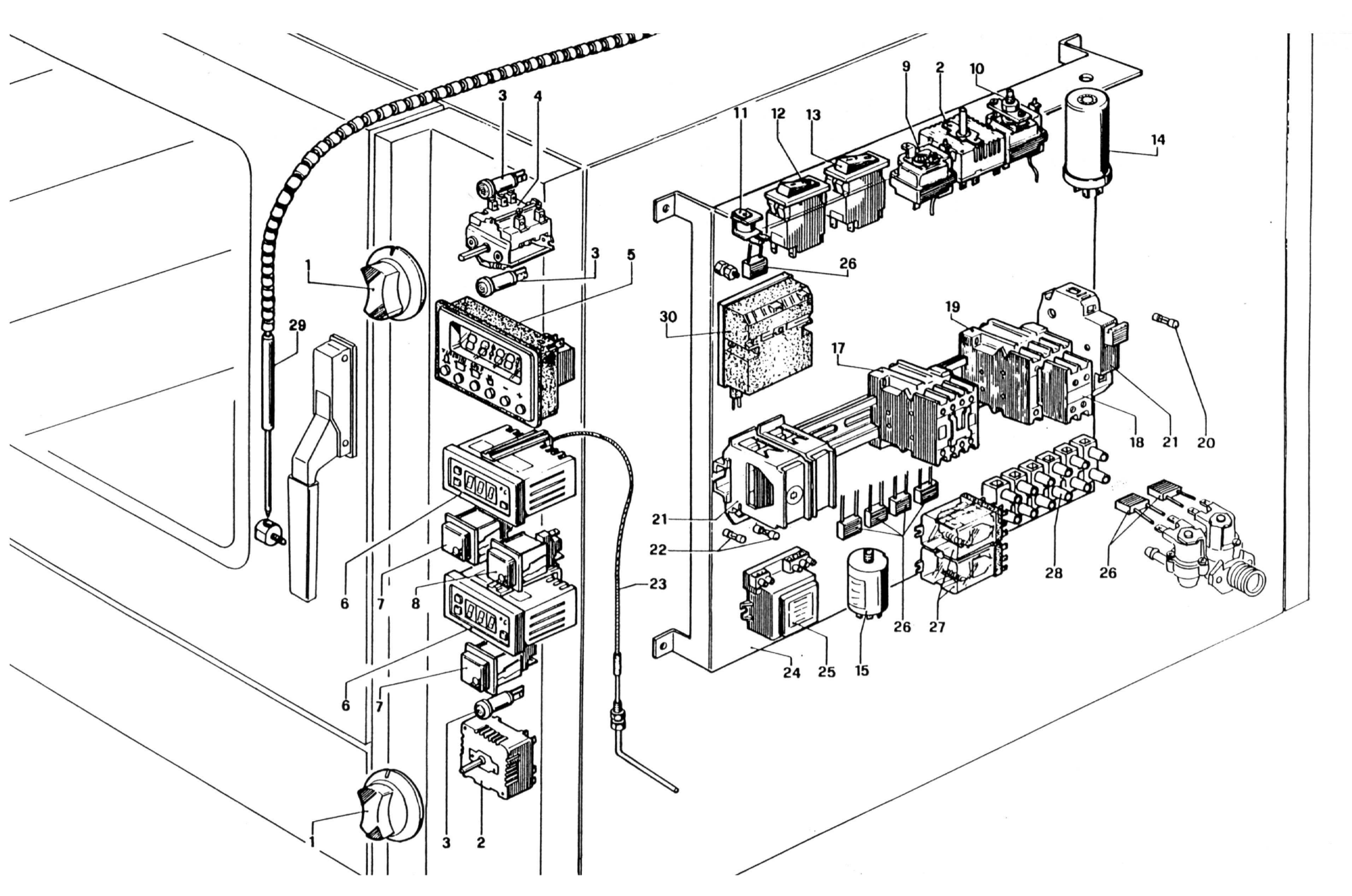

TAV.248		Apparecchiature Elettriche	Appareillages Electriques	Electrical Equipment	Elektrogeräte	FGMD065	FGMD066
	Codice	Denominazione	Denominaton	Denominaton	Bezeichnung		
1	RTFOC00055	Manopola comando	Mannette de commande	Control knob	Steuerdrehknopf	×	×
2	RTCU800066	Regolatore d' energia	Régulateur d'energie	Power regulator	Energie Regler	×	×
3	RTCU900072	Lampada spia gialla	Lampe témoin jaune	Yellow warning lamp	Gelbe Kontrolleuchtenbirne	×	×
4	RTFOC00143	Commutatore	Commutateur du four	Oven commutator	Kommutator	×	×
5	RTFOC00405	Timer elettronico	Timer électronique	Electronic timer	Elektro-Timer	×	×
6	RTFOC00029	Termostato elettronico	Thermostat électronique	Electronic thermostat	Elektro-Thermostat	×	×
7	RTFOC00362	Pulsante 2 velocità	Bouton 2 vitesses	Two-speed button	Taste 2 Geschwindigkeit	×	×
8	RTFOC00387	Pulsante luce	Bouton lumière	Light button	Lichttaste	×	×
9	RTFOC00300	Termostato	Thermostat	Thermostat	Thermostat	×	×
10	RTFOC00232	Termostato limit	Thermostat Limit	Limit thermostat	Limit Thermostat	×	×
11	RTFOC00046	Ronzatore	Bourdonneur	Buzzer	Summer	×	×
12	RTFOC00044	Termica 0,8A	Interrupteur thermique 0,8A	Overload switch 0,8A	Thermoschutzschalter 0,8A	×	×
13	RTFOC00045	Termica 3A	Interrupteur thermique 3A	Overload switch 3A	Thermoschutzschalter 3A	×	×
14	RTFOC00053	Condensatore	Condensateur	Condenser	Kondensator	×	×
15	RTFOC00309	Antidisturbo radio	Antiparasitage radio	Antijamming	Funkentstörung	×	×
16	RTFOC00042	Ciclatore 50Hz	Cycleur 50 Hz	Buzzer 50Hz	Taktvorrichtung 50Hz	×	×
17	RTFOC00438	Relais FCV	Relais FCV	Relais FCV	Relais FCV	×	×
18	RTFOC00440	Contatti ausiliari	Contacs auxiliaires	Auxiliary contacts	Nebenkontakte	×	×
19	RTFOC00439	Relais	Relais	Relais	Relais	×	×
20	RTFOC00284	Fusibile 6,3A	Fusibile 6,3A	Fuse 6,3A	Schmelzsicherung 6,3A	×	×
21	RTFOC00048	Portafusibile	Porte-fusibile	Fuse -holder	Sicherungsschalter	×	×
22	RTFOC00047	Fusibile 0,1A	Fusibile 0,1A	Fuse 0,1A	Schmelzsicherung 0,1A	×	×
23	RTFOC00321	Termocoppia 60	Thermocouple 60	Thermocouple 60	Thermoelement 60	×	×
24	PAFOC00029	Supporto componenti elettrici	Support composants électriques	Electrical components support	Halterung elektronischer Komponenten	×	×
25	RTFOC00039	Transformatore 220/12V	Transformateur el. 220/12V	Electric transformer 220/12V	Transformator 220/12V	×	×
26	RTFOC00023	Antidisturbo radio	Antiparasitage radio	Antijamming	Funkentstörung	×	×
27	RTFOC00144	Relais boiler	Relais bouilleur	Boiler relais	Relais	×	×
28	RTBF900045	Morsetteria 6 poli	Groupe de connec. des cables	Terminal bloc 6 poles	Klemmbreit 6 polig	×	×
29	RTFOC00130	Sonda al cuore cm. 55	Sonde thermique cm. 55	Thermic probe 55 cm	Wärmefühler 55 cm	×	×
30	RTBF800129	Accenditore elettrico	Allumage électrique	Electric lightning	Elektrischer Anzünder	×	×

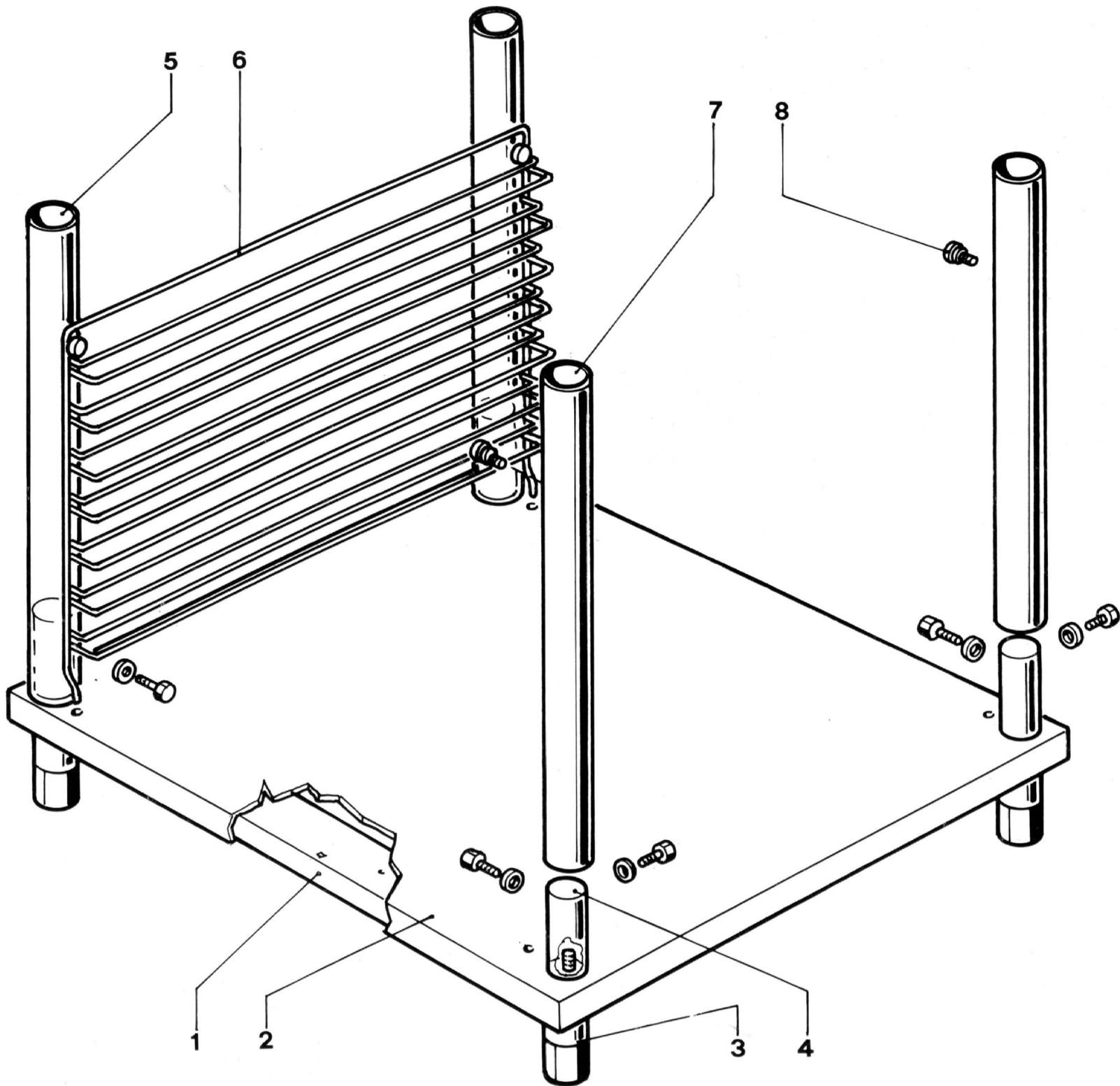

TAV.204		Supporto forno	Support du four	Oven support	Ofenhalterung	
	Codice	Denominazione	Denominaton	Denominaton	Bezeichnung	
1	GAFOC00077	Basamento supporto forno	Soubassement du support	Oven support base	Untergestell	×
2	PAFOC00133	Ripiano supporto forno	Fonde support du four	Oven support bottom	Boden	×
3	RTFOC00119	Piedino	Pied	Foot	Inox-Fuß	×
4	RTFOC00121	Rinforzo gamba	Rentort jambe	Leg bracing	Verstärkung	×
5	PAFOC00134	Gamba sinistra	Jambe gauche	Left leg	Linker Fuß	×
6	RTFOC00122	Griglia laterale	Grille latérale	Lateral grate	Seitenrost	×
7	PAFOC00135	Gamba destra	Jambe droite	Right leg	Rechter Fuß	×
8	RTBF700043	Attacco griglia	Attaque grille	Grate connection	Seitenanschluß	×