

POS.	CODICE CODE KODE	POS.	CODICE CODE KODE	POS.	CODICE CODE KODE	POS.	CODICE CODE KODE
1	02 50 02	33	99 30 24	64	99 10 01		
2	{ 21 60 02 21 60 03	34	11 00 02	65	43 70 07		
3	44 70 07	35	14 00 06	66	14 30 04		
4/5	44 70 08	36	13 80 01	67	99 90 34		
6	21 30 02	37	98 40 02	68	14 20 10		
7	21 20 01	38	46 80 29	69	14 20 01		
8	23 60 07	39	{ 45 60 20 43 70 19	70	{ 43 70 38 43 70 33		
9	pag. 90	41	98 50 02	71	99 90 43		
10	22 40 02	42	12 70 11	72	41 50 01		
11	99 90 36	43	98 50 01	73	20 30 29		
12	99 40 06	44	43 70 27	74	20 40 14		
13	99 40 05	45	02 20 19	75	42 50 01		
14	99 90 37	46	02 20 18	76	pag. 93		
15	{ 48 00 15 48 00 16	47	99 90 08				
16	02 00 08	48	21 80 02				
17	02 10 06	49	10 80 05				
18	02 10 06	50	pag. 104				
19	32 20 03	51	12 70 06				
20	99 90 38	52	12 70 07				
21	99 90 39	53	{ 98 70 01 98 70 05				
22	31 90 02	54	{ 20 10 02 20 10 11				
23	12 10 12	55	14 30 13				
24	99 00 34	56	12 10 17				
25	99 00 33	57	14 30 05				
26	99 00 35	58	46 10 06				
27	99 90 30	59	98 20 04				
28	14 00 02	60	23 00 24				
29	11 90 01	61	43 70 29				
30	11 00 05	62	43 50 01				
31	14 00 03	63	43 70 31				
32	11 90 02						

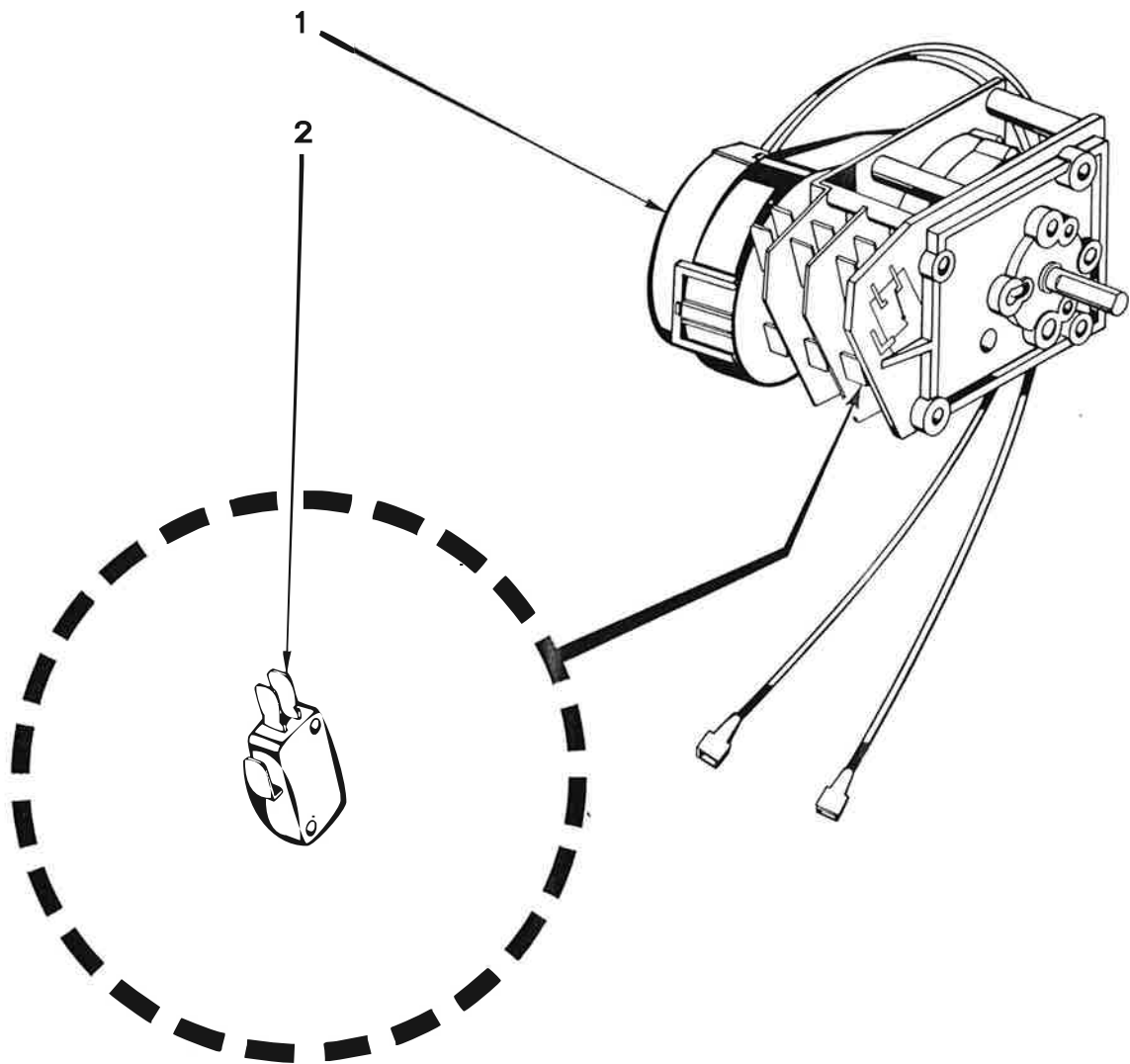

POS.	CODICE CODE KODE	DESCRIZIONE - DESCRIPTION - BESCHREIBUNG
1	23 80 25	Timer ciclo 180" - Cronel 2C Cycle timer 180" - Cronel 2C Programmateur cycle 180" - Cronel 2C Programmschalter 180" - Cronel 2C 220/50/1 Mod. R 495 - 497
1	23 80 01	Timer ciclo 180" - Crouzet 3C Cycle timer 180" - Crouzet 3C Programmateur cycle 180" - Crouzet 3C Programmschalter 180" - Crouzet 3C 220/50/1 Mod. R 499 - 501 - 503 - 505 - 507 - 509 - 511 - 704 - 706 - 708 - S 641 - 643  Mod. S 870 fino matricola n° 64902 till serial no. 64902 au matricule n° 64902 bis Maschinen-Nr. 64902
1	23 80 24	Timer ciclo 180" - Cronel 3C Cycle timer 180" - Cronel 3C Programmateur cycle 180" - Cronel 3C Programmschalter 180" - Cronel 3C 220/50/1 Mod. R 499 - 501 - 503 - 505 - 507 - 509 - 511 - 704 - 706 - 708 - S 641 - 643  Mod. S 870 fino matricola n° 64902 till serial no. 64902 au matricule n° 64902 bis Maschinen-Nr. 64902
1	23 80 05	Timer ciclo 180" - Cronel 3C Cycle timer 180" - Cronel 3C Programmateur cycle 180" - Cronel 3C Programmschalter 180" - Cronel 3C 220-240/50/1 Mod. R 499 - 501 - 503 - 505 - 507 - 509 - 511 - 704 - 706 - 708 - S 641 - 643  Mod. S 870 fino matricola n° 64902 till serial no. 64902 au matricule n° 64902 bis Maschinen-Nr. 64902
1	23 80 16	Timer ciclo 180" - Cronel 3C Cycle timer 180" - Cronel 3C Programmateur cycle 180" - Cronel 3C Programmschalter 180" - Cronel 3C 220/60/1 Mod. R 499 - 501 - 503 - 505 - 507 - 509 - 511 - 704 - 706 - 708 - S 641 - 643  Mod. S 870 fino matricola n° 64902 till serial no. 64902 au matricule n° 64902 bis Maschinen-Nr. 64902

POS.	CODICE CODE KODE	DESCRIZIONE - DESCRIPTION - BESCHREIBUNG
1	23 80 09	Timer pompa scarico 180" - Cronel 4C Drain pump timer 180" - Cronel 4 Programmateur pompe vidange 180" - Cronel 4C Laugenpumpe-Programmschalter 180" - Cronel 4C 220/50/1 Mod. R 501 - 505 - 509 - 704 - 706 - 708 - S 641  Mod. S 870 fino matricola n° 64902 till serial no. 64902 au matricule n° 64902 bis Maschinen-Nr. 64902
2	21 80 09	Micro timer Cronel Microtimer Cronel Minirupteur programmeur Cronel Mikroschalter Cronel

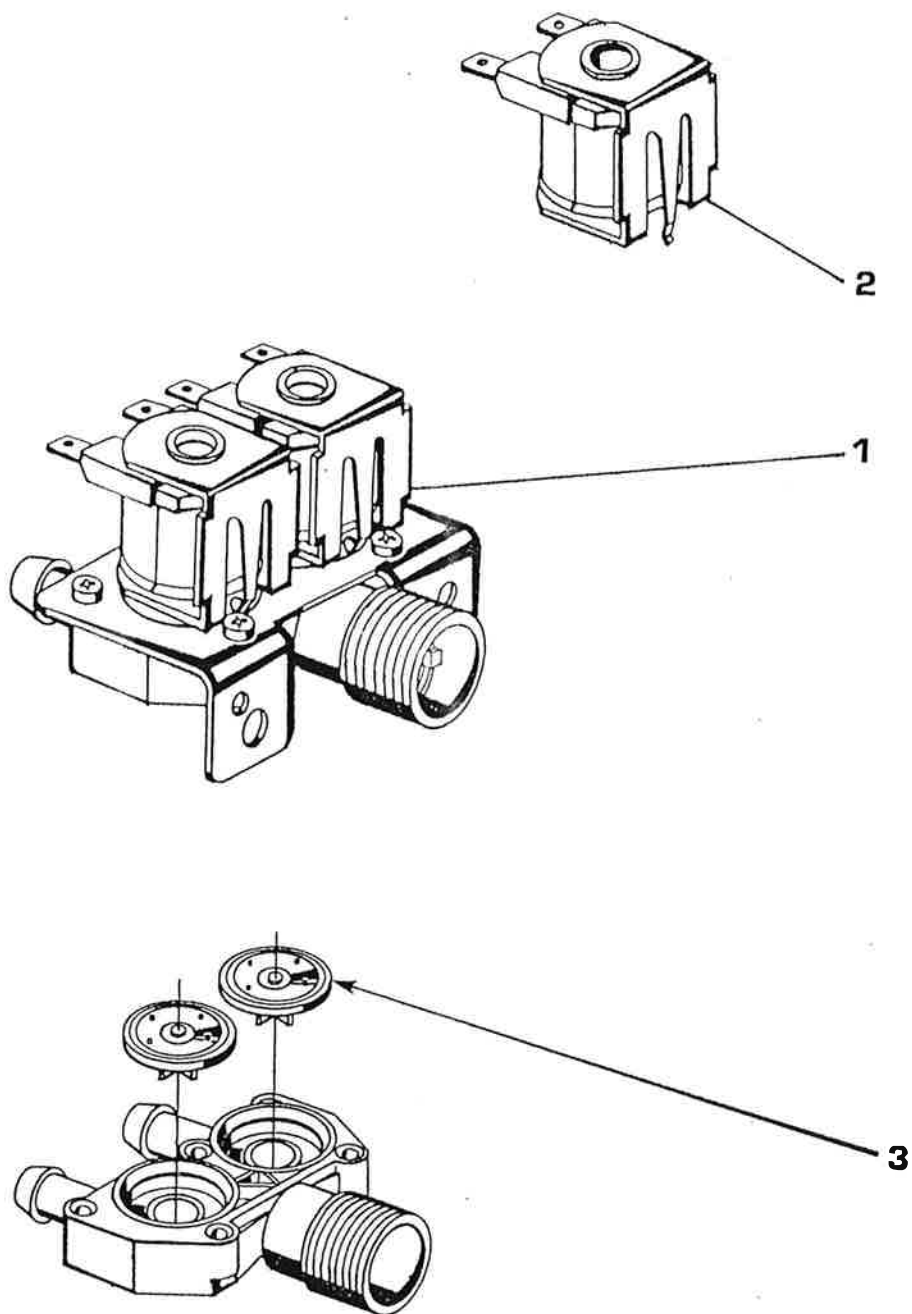

POS.	CODICE CODE KODE	DESCRIZIONE - DESCRIPTION - BESCHREIBUNG
1	24 00 06	Valvola - Elbi - 1 via 90° Solenoid valve - Elbi - 1 way 90° Vanne - Elbi - 1 bobine 90° Einweg - Einlassmagnetventil - Elbi - 90° 220-240/50-60/1 Mod. R 495
1	24 00 05	Valvola - Elbi - 1 via 180° Solenoid valve - Elbi - 1 way 180° Vanne - Elbi - 1 bobine 180° Einweg - Einlassmagnetventil - Elbi - 180° 220-240/50-60/1 Mod. R 704 - 706
1	24 00 03	Valvola - 2 vie 180° Solenoid valve - 2 ways 180° Vanne - 2 bobines 180° Zweiweg - Einlassmagnetventil - 180° 220-240/50-60/1 Mod. R 497 - 499 - 501 - 505 - 509 - S 641
1	24 00 02	Valvola - 3 vie 180° Solenoid valve - 3 ways 180° Vanne - 3 bobines 180° Dreiweg - Einlassmagnetventil - 180° 220-240/50-60/1 Mod. R 503 - 507 - 511 - S 643
1	24 00 08	Valvola ottone piccola portata Brass solenoid valve - small capacity Vanne laiton - petite Kleines Einlassmagnetventil aus Messing 220-240/50-60/1 Mod. R 708
1	24 00 07	Valvola ottone grande portata Brass solenoid valve - big capacity Vanne laiton - grande Grosses Einlassmagnetventil aus Messing 220-240/50-60/1 Mod. S 870 fino matricola n° 64902 till serial no. 64902 au matricule n° 64902 bis Maschinen-Nr. 64902

OS.	CODICE CODE KODE	DESCRIZIONE - DESCRIPTION - BESCHREIBUNG
2	20 10 06	Bobina valvola Coil for solenoid valve Bobine pour vanne Spule für Einlassmagnetventil
2	20 10 08	Bobina valvola ottone piccola portata Coil for brass solenoid valve - small capacity Bobine vanne laiton petite Spule für kleines Einlassmagnetventil aus Messing
2	20 10 07	Bobina valvola ottone grande portata Coil for brass solenoid valve - big capacity Bobine vanne laiton grande Spule für grosses Einlassmagnetventil aus Messing
3	29 90 22	Membrana valvola ottone grande portata Membrane for brass solenoid valve - big capacity Membrane vanne laiton grande Membran für grosses Einlassmagnetventil aus Messing

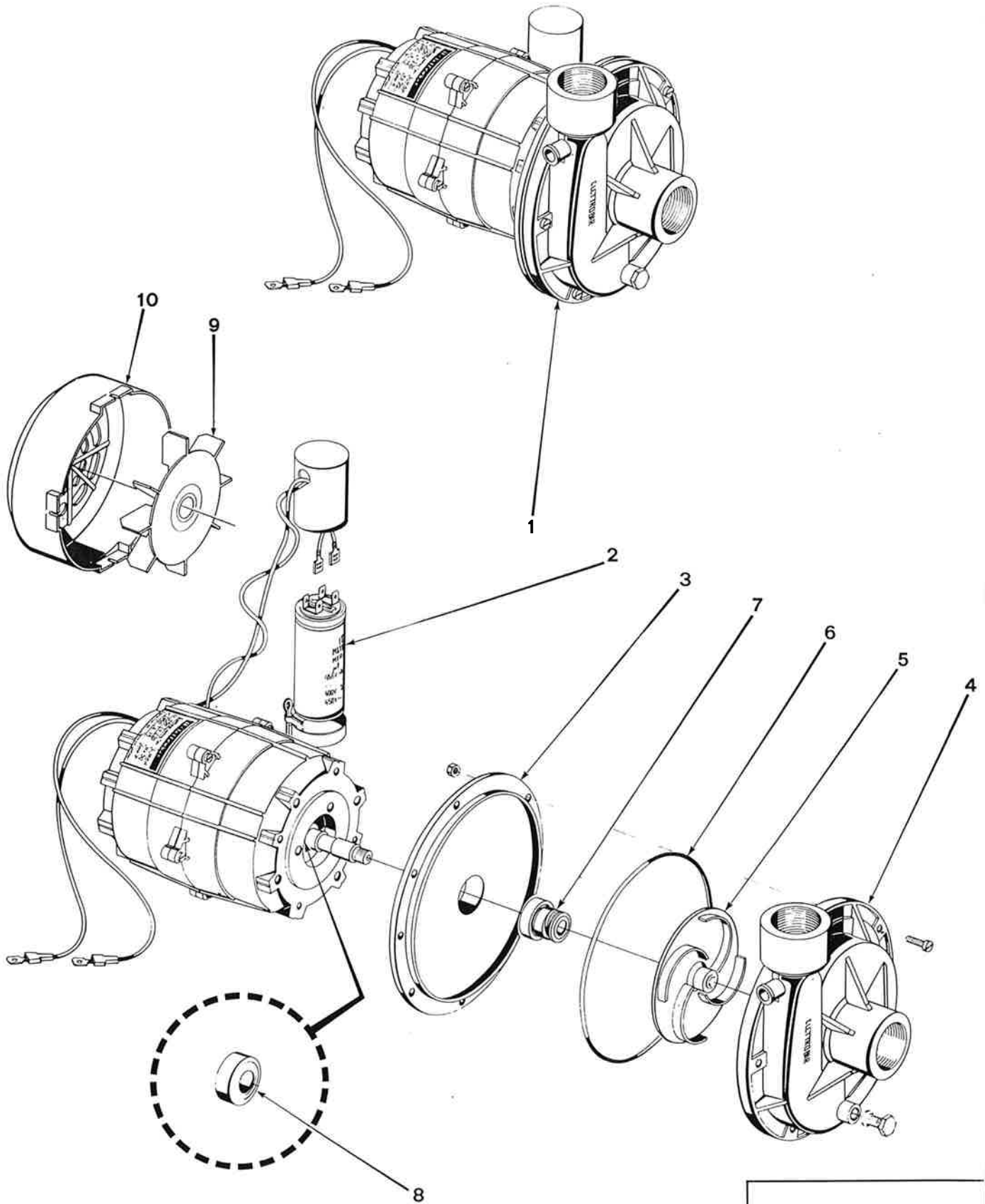

**E3 wolk**

POMPA  
WASH PUMP  
POMPE  
ELEKTROPUMPE

mod. R:  
706 - 708

105

10/87

POS.	CODICE CODE KODE	DESCRIZIONE - DESCRIPTION - BESCHREIBUNG
1	13 00 24	Pompa 1295 FIR HP 1,2 Wash pump 1295 FIR HP 1,2 Pompe 1295 FIR HP 1,2 Elektropumpe 1295 FIR HP 1,2 220/380/50/3
1	13 00 29	Pompa 1295 FIR HP 1,2 Wash pump 1295 FIR HP 1,2 Pompe 1295 FIR HP 1,2 Elektropumpe 1295 FIR HP 1,2 220/380/60/3
1	13 00 30	Pompa 1295 FIR HP 1,2 Wash pump 1295 FIR HP 1,2 Pompe 1295 FIR HP 1,2 Elektropumpe 1295 FIR HP 1,2 220/60/1
1	13 00 09	Pompa LC T 140 HP 1 Wash pump LC T 140 HP 1 Pompe LC T 140 HP 1 Elektropumpe LC T 140 HP 1 220/50/1
2	20 60 05	Condensatore T 140, 1295 FIR Condenser T 140, 1295 FIR Condensateur T 140, 1295 FIR Kondensator T 140, 1295 FIR
3	31 50 04	Flangia + cappello 1295 FIR Flange int. 1295 FIR Flansque int. 1295 FIR Flansch 1295 FIR
3	31 50 09	Flangia + cappello T 140 Flange T.140 Flansque T 140 Flansch T 140
4	11 60 04	Corpo pompa 1295 FIR Flange ext. 1295 FIR Flansque ext. 1295 FIR Pumpengehäuse 1295 FIR
4	11 60 11	Corpo pompa T 140 Flange ext. T 140 Flansque ext. T 140 Pumpengehäuse T 140
5	12 40 04	Girante 1295 FIR 50 Hz. Impellor 1295 FIR 50 Hz. Turbine 1295 FIR 50 Hz. Pumpenflügel 1295 FIR 50 Hz.

**E3 wolk**

POMPA  
WASH PUMP  
POMPE  
ELEKTROPUMPE

mod. R:  
706 - 708

106

10/87

POS.	CODICE CODE KODE	DESCRIZIONE - DESCRIPTION - BESCHREIBUNG
5	12 40 22	Girante 1295 FIR 60 Hz. Impellor 1295 FIR 60 Hz. Turbine 1295 FIR 60 Hz. Pumpenflügel 1295 FIR 60 Hz.
5	12 40 09	Girante T 140 50 Hz. Impellor T 140 50 Hz. Turbine T 140 50 Hz. Pumpenflügel T 140 50 Hz.
6	45 60 23	OR 1295 FIR O-ring 1295 FIR Joint thorique 1295 FIR O-Ring Dichtung 1295 FIR
6	45 60 24	OR T 140 O-ring T 140 Joint thorique T 140 O-Ring Dichtung T 140
7	14 10 02	Tenuta meccanica 1295 FIR, T 140 Seal 1295 FIR, T 140 Presse etoupe 1295 FIR, T 140 Gleitringdichtung 1295 FIR, T 140
8	31 40 02	Cuscinetto T 140 Bearing T 140 Roulement T 140 Kugellager T 140
9	33 50 03	Ventola 1295 FIR Fan 1295 FIR Turbine de refroidissement 1295 FIR Flügel 1295 FIR
9	33 50 05	Ventola T 140 Fan T 140 Turbine de refroidissement T 140 Flügel T 140
10	31 30 03	Copriventola 1295 FIR Fan protection 1295 FIR Protection turbine 1295 FIR Flügelschutz 1295 FIR
10	31 30 06	Copriventola T 140 Fan protection T 140 Protection turbine T 140 Flügelschutz T 140

**E3 wolk**



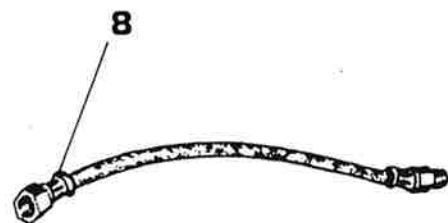
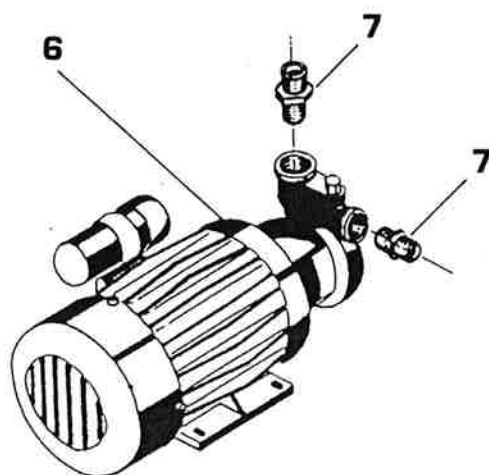
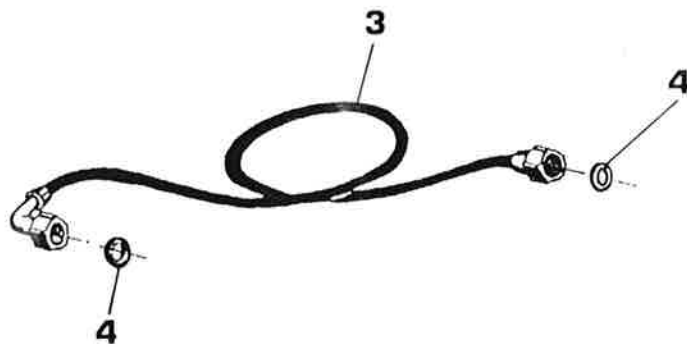
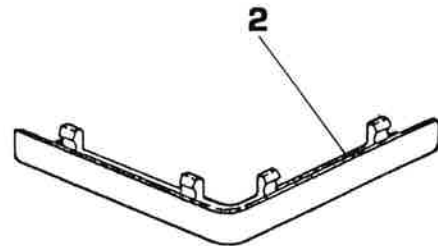
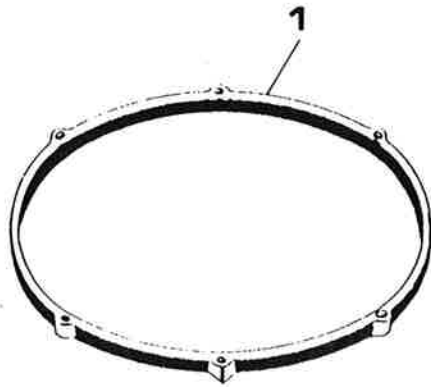

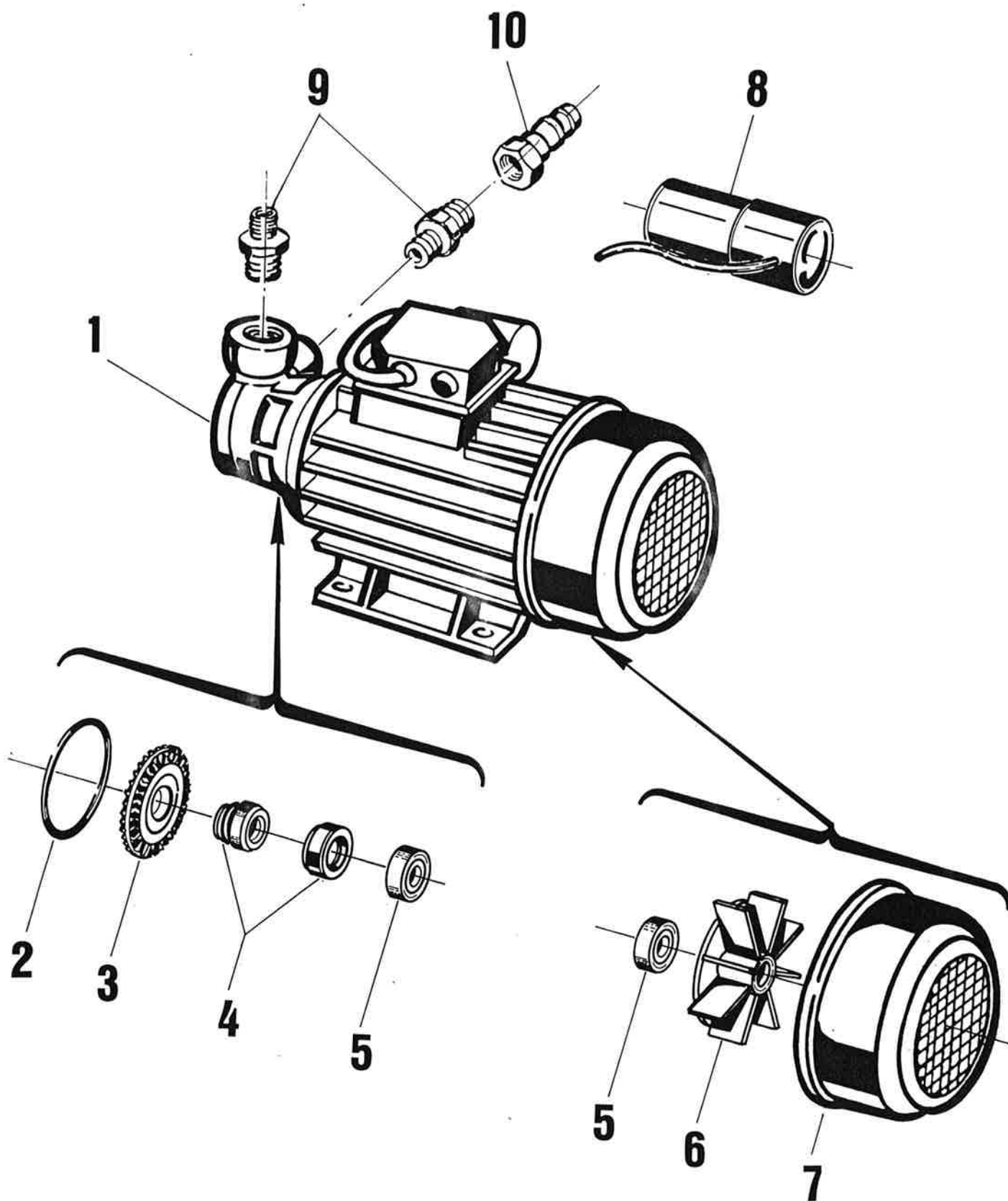

POS.	CODICE CODE KODE	DESCRIZIONE - DESCRIPTION - BESCHREIBUNG	
1	13 00 13	Pompa ausiliaria Dab K 30 HP 0,4 Rinse booster pump Dab K 30 HP 0,4 Pompe rincage Dab K 30 HP 0,4 Nachspülpumpe Dab K 30 HP 0,4	220/50/1 Per tutti i modelli For all the models Tous modeles Für alle Modelle
1	13 00 52	Pompa ausiliaria Dab K 30 HP 0,4 Rinse booster pump Dab K 30 HP 0,4 Pompe rincage Dab K 30 HP 0,4 Nachspülpumpe Dab K 30 HP 0,4	240/50/1 Per tutti i modelli For all the models Tous modeles Für alle Modelle
2	45 60 37	OR K 30 O-ring K 30 Joint thorique K 30 O-Ring Dichtung K 30	
3	12 40 15	Girante K 30 Impellor K 30 Turbine K 30 Pumpenflügel K 30	
4	14 10 02	Tenuta meccanica K 30 Seal K 30 Presse etoupe K 30 Gleitringdichtung K 30	
5	31 40 01	Cuscinetto K 30 Bearing K 30 Roulement K 30 Kugellager K 30	
6	33 50 07	Ventola K 30 Fan K 30 Turbine de refroidissement K 30 Flügel K 30	
7	31 30 08	Copriventola K 30 Fan protection K 30 Protection turbine K 30 Flügelschutz K 30	
8	20 60 01	Condensatore K 30 Condenser K 30 Condensateur K 30 Kondensator K 30	
9	46 80 26	Raccordo K 30 Connection K 30 Raccord K 30 Anschluss K 30	
10	45 30 02	Raccordo pompa ausiliaria Dab K 30 Rinse booster pump connection Dab K 30 Raccord pompe rincage Dab K 30 Nachspülpumpeanschluss Dab K 30	Mod. S 850 - 870 - 950

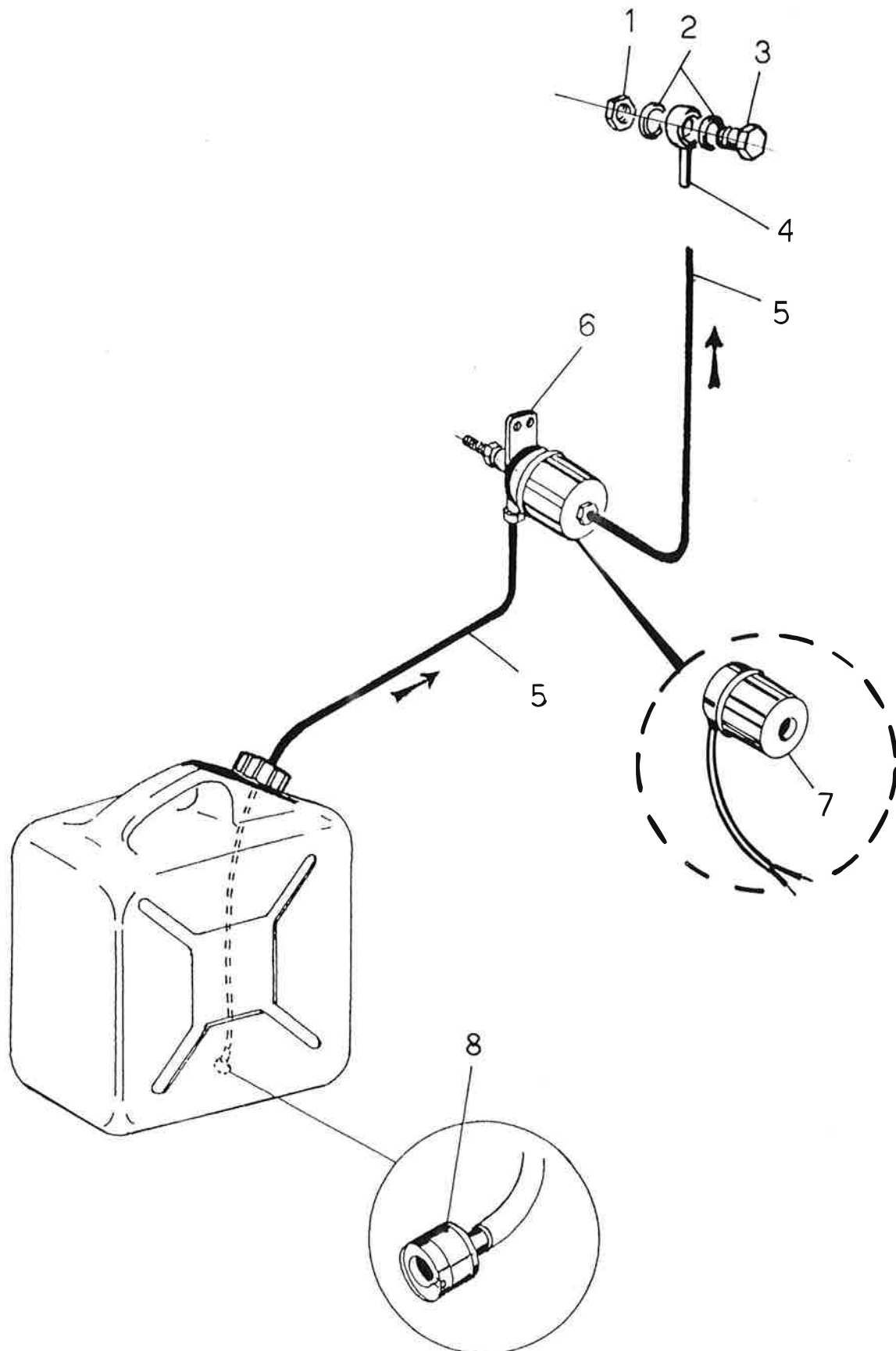



DOSATORE SAPONE  
LIQUID DETERGENT DISPENSER  
DOSEUR DU PRODUIT DE LAVAGE  
SPUELMITTEL-DOSIERGERAET

121

10/87

POS.	CODICE CODE KODE	POS.	CODICE CODE KODE	POS.	CODICE CODE KODE	POS.	CODICE CODE KODE
1	41 70 16						
2	43 70 07						
3	46 80 24						
4	46 80 23						
5	14 30 14						
6	98 70 12						
7	20 10 18						
8	98 60 02						

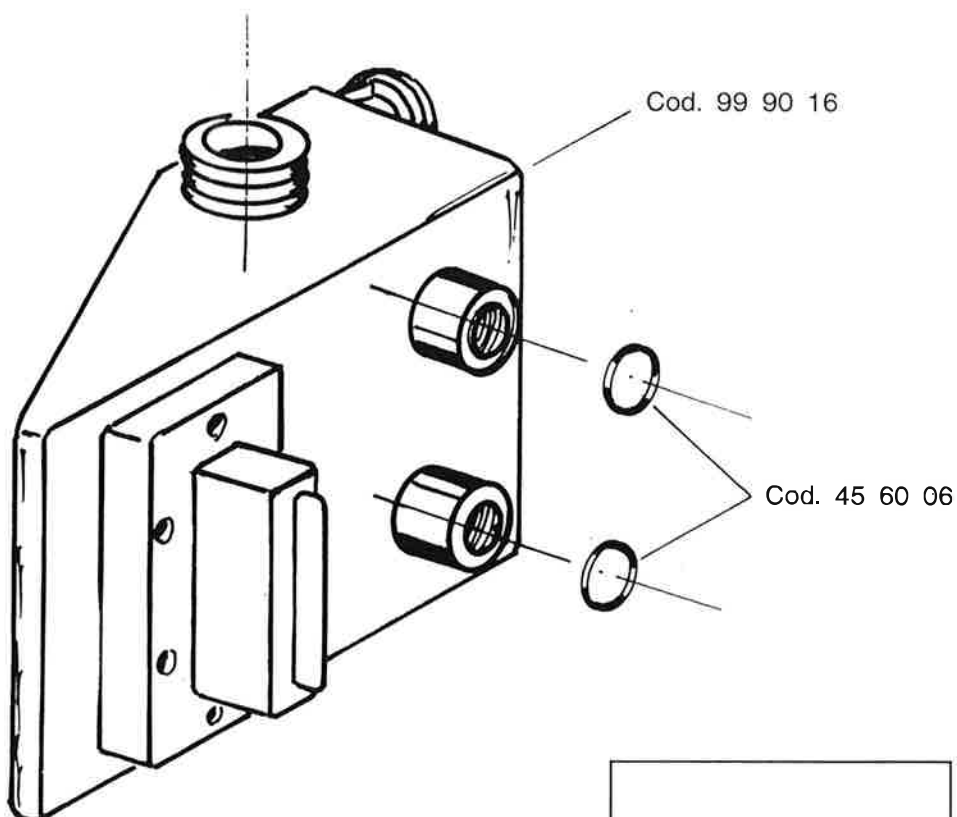
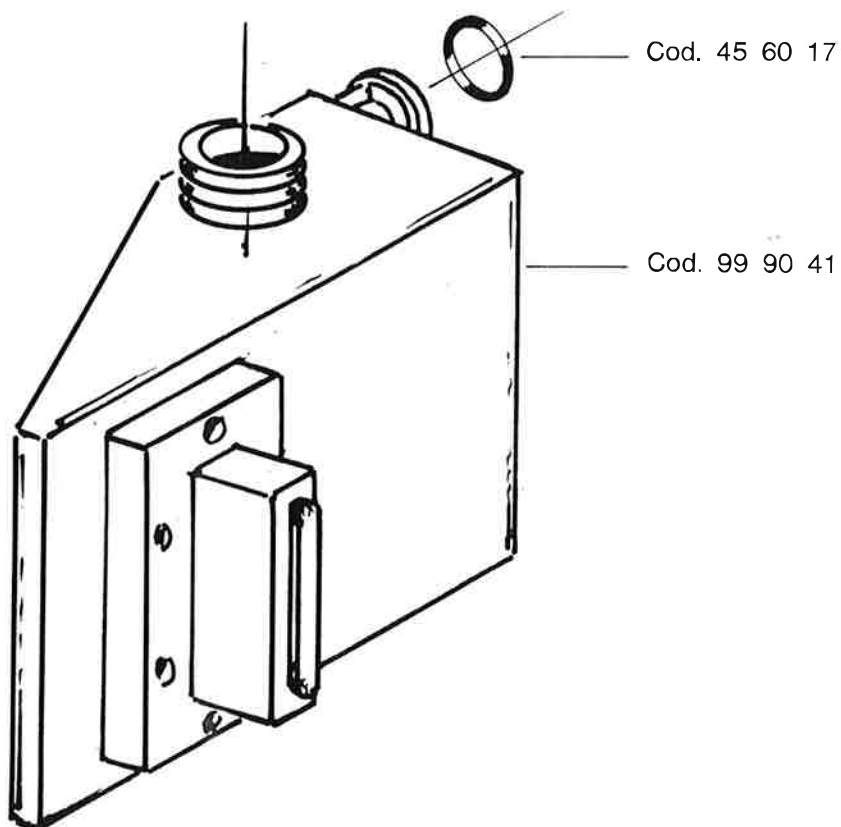

NUOVO  
NEW  
NOUVEAU  
NEU

DA MATRICOLA N° 68473  
DE MATRICULE NR. 68473  
FROM SERIAL NO. 68473  
AB MASCHINEN NR. 68473

**E3 wolk**

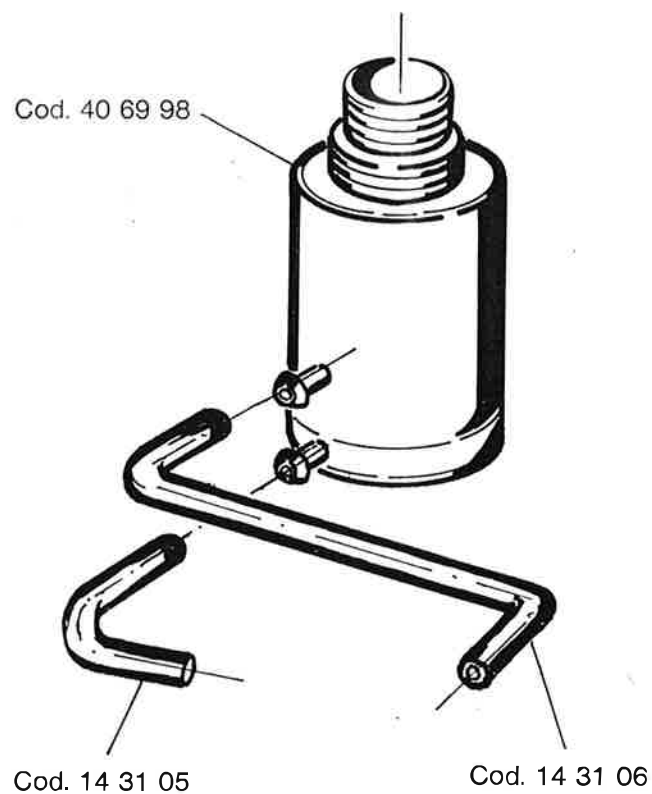
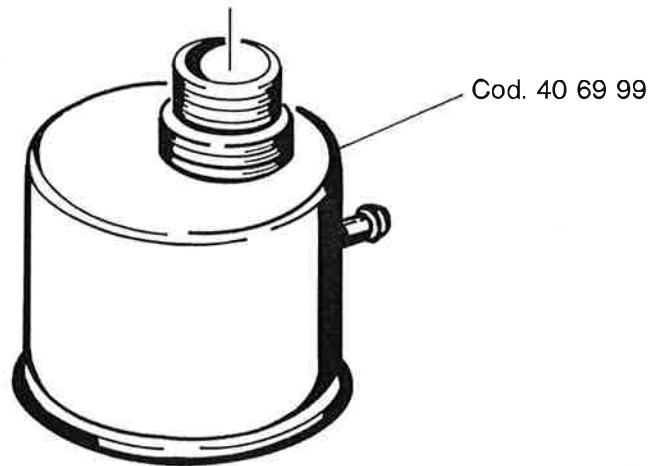

**NUOVO  
NEW  
NEU  
NOUVEAU**

DA MATRICOLA N° 92582  
FROM SERIAL NO. 92582  
AB MASCHINEN NR. 92582  
DU MATRICULE NO. 92582