

IF IN DOUBT ASK!!

DO NOT SCALE !!
First Angle Projection

G2840/1/2 SINGLE PAN FRYER - FITMENTS

Part No.	Spares No.	Description
1	535770000	Outer Flue Panel
2	535770001	Flue Hole Plug
3	535770002	Basket Hanging Rail
4	535770003	Hob And Pan Assembly
5	535770004	Pan Lid (No Basket Lift)
6	535770005	Chip Basket (Basket Lift Model Only) Pre F-----
	535770089	Chip Basket (All Other Models)
7	535770006	Fish Plate
8	535770011	Drain Valve Assembly
9	535770012	Drain Outlet Pipe
10	535770013	Drain Handle Spacer
11	535770014	Drain Handle c/w Sleeve
12	535770015	Drain Handle Sleeve
13	535770048	Flue Riser
14	535770049	Flue Riser Gasket
15	535780000	Pan Lid (Basket Lift)
16	535770088	Drain Prod

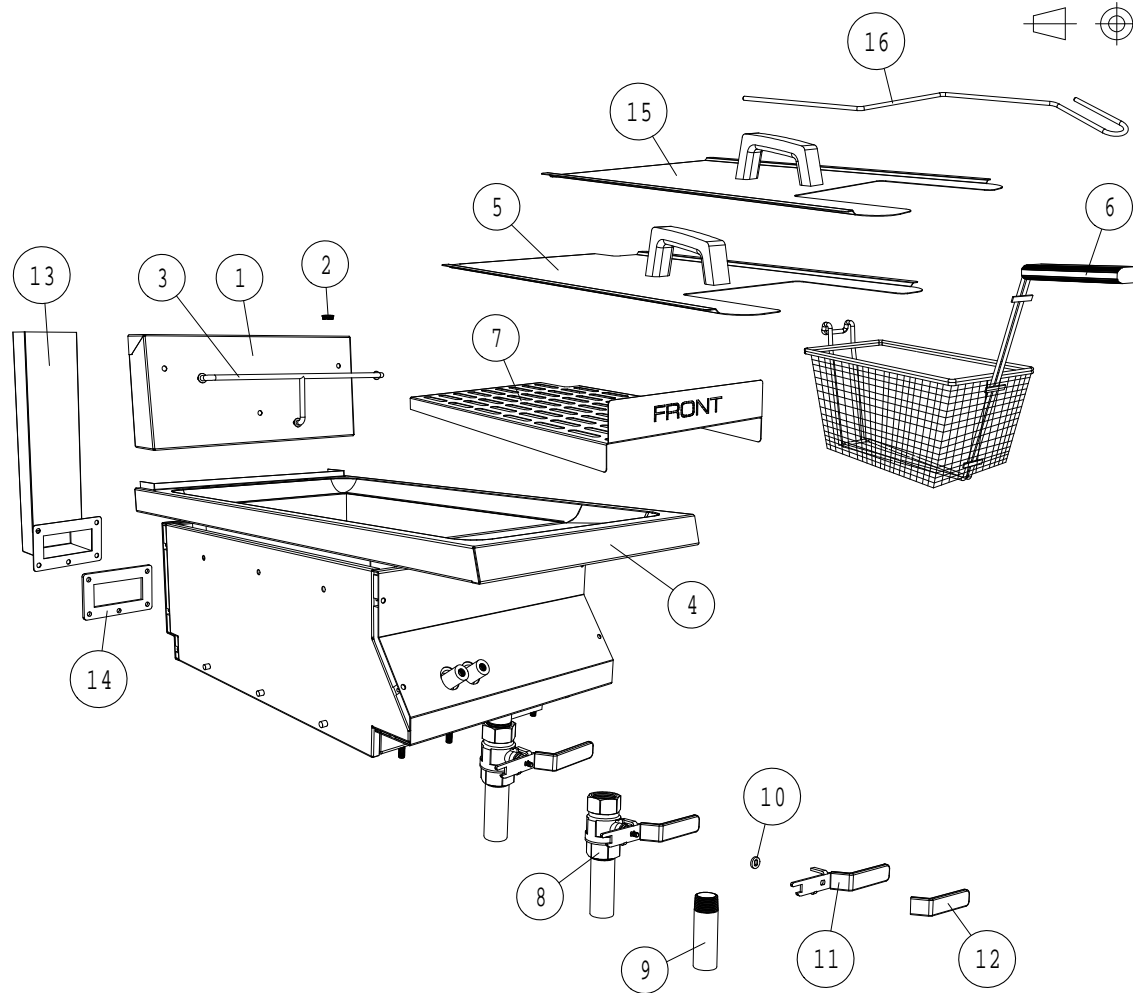

All Dimensions in millimetres, Tolerance- Linear ±0.5mm Angular ±0.5° (or as stated)

Issue	Mod No.	Alteration	Zone	Drawn by	Date
B	5168	BASKET MODIFIED		G.SMITH	26/07/04
A	977/14	PRODUCTION ISSUE		G.SMITH	18/02/04



This part is common to the following units

Drawn	G.SMITH	Product	G2840/1/2 SINGLE PAN FRYER	
Date	18/02/04	Title	SPARES - FITMENTS	
Scale	N.T.S.			
Matl.		Drawing Number	AD42328	Issue
No. off		Bin No.	1111391	

© No reproduction or publication of this drawing may be made and no article may be manufactured or assembled in accordance with this drawing without prior written consent. This prohibition is a term of any contract relating to this drawing. Rights reserved under the Copyright Act 1956 as amended by the Design Copyright Act 1968.

UNCONTROLLED

IF IN DOUBT ASK!!

DO NOT SCALE !!

First Angle Projection

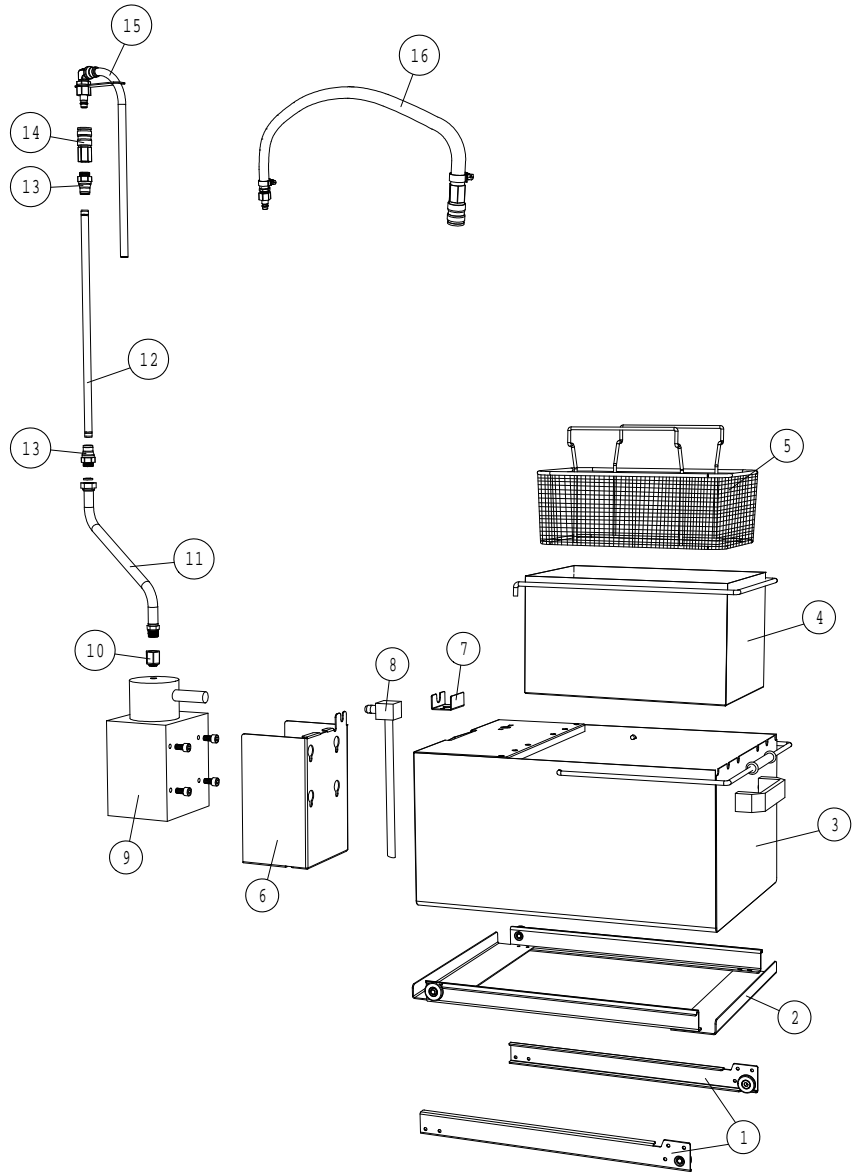

G2840/1/2 SINGLE PAN FRYER - OIL FILTRATION

Part No.	Spares No.	Description
1	535770026	Oil Container Runners
2	535770028	Oil Container Roller Carrier
3	535770029	Oil Container
4	535770030	Fine Mesh Filter Assembly
5	535770032	Basket Filter
6	535770074	Oil Pump Mounting Bracket
7	535770075	Oil Pick-Up Pipe Bracket
8	535770076	Oil Pick-Up Pipe c/w Washer
9	535770077	Oil Pump c/w Screws
10	535770078	Increaser c/w Washer
11	535770080	St/St Flexible Hose c/w Washer
12	535770083	St/St Rigid Oil Pipe
13	535770084	Male Push-In Fitting
14	535770085	Quick Release Connection c/w Joint Disc
15	535770086	Removable Oil Delivery Hose
16	535770087	Oil Return Hose Extension

All Dimensions in millimetres, Tolerance- Linear $\pm 0.5\text{mm}$ Angular $\pm 0.5^\circ$ (or as stated)

© No reproduction or publication of this drawing may be made and no article may be manufactured or assembled in accordance with this drawing without prior written consent. This prohibition is a term of any contract relating to this drawing. Rights reserved under the Copyright Act 1956 as amended by the Design Copyright Act 1988.

This part is common to the following units

Drawing Number	BD42331					
	B	5162	OIL RETURN SYSTEM AMENDED	G. SMITH	07/07/04	
	A	977/14	PRODUCTION ISSUE	G. SMITH	18/02/04	
Issue	Mod No.	Alteration	Zone	Drawn by	Date	

Drawn	G. SMITH	Product	G2840/1/2 SINGLE PAN FRYER		
Date	18/02/04	Title	SPARES - OIL FILTRATION		
Scale	N.T.S.	Drawing Number	BD42331		
Matl.		Issue			
No. of		Bin No.	T111393		
Bin No.		Kraus No.	T111393		



UNCONTROLLED

IF IN DOUBT ASK!!

DO NOT SCALE !!

First Angle Projection



G2840/1/2 SINGLE PAN FRYER - OUTER PANELS		
Part No.	Spares No.	Description
1	535770010	FALCON BADGE
2	535770016	DOOR HINGE
3	535770017	DOOR ASSEMBLY
4	535770018	RH OUTER SIDE PANEL
5	535770019	LH OUTER SIDE PANEL
6	535770020	ADJUSTABLE FOOT (1 OFF)
7	535770021	CASTOR (1 OFF)
8	535770045	REMOVABLE OUTER BACK (NO BASKET LIFT)
9	535770046	GAS INLET PIPE ASSEMBLY
10	535770047	PRESSURE TEST NIPPLE
11	535780001	REMOVABLE OUTER BACK (WITH BASKET LIFT)

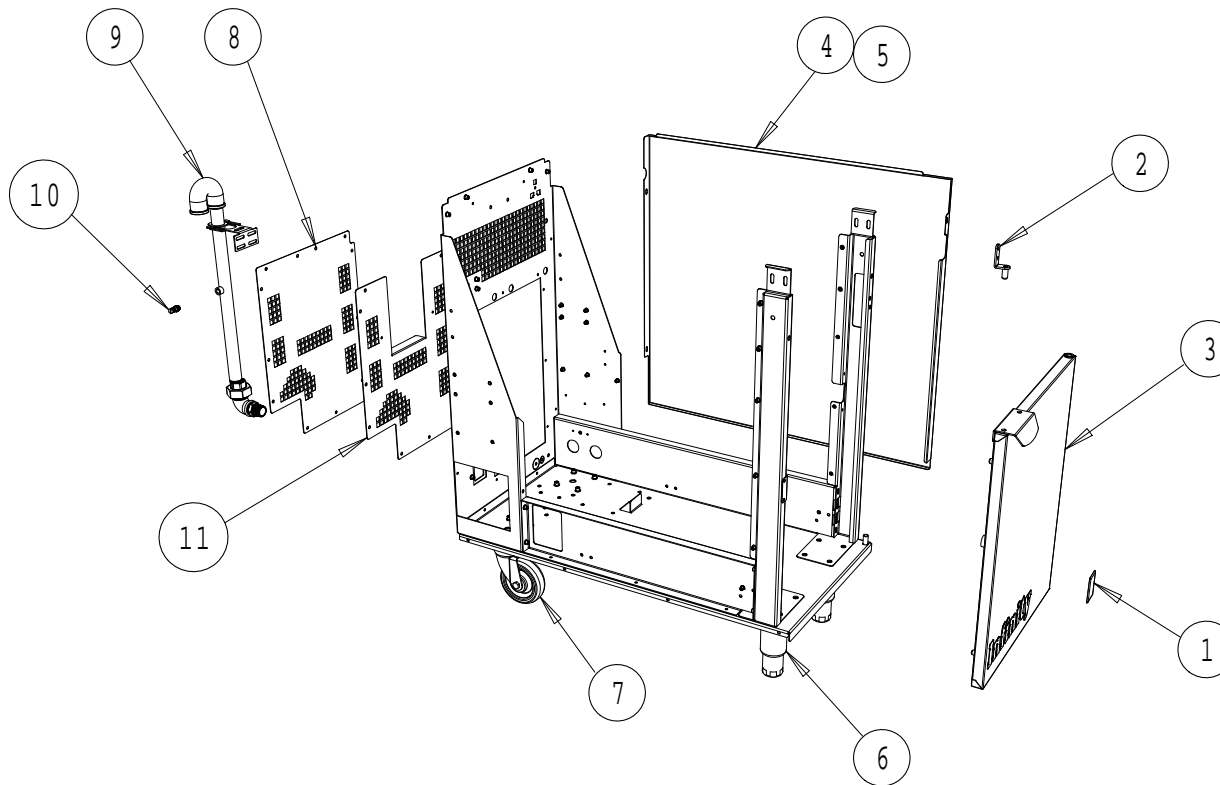

All Dimensions in millimetres, Tolerance- Linear $\pm 0.5\text{mm}$ Angular $\pm 0.5^\circ$ (or as stated)

Drawing Number	BD42329						
	B	SPARES ISSUE - ISSUE B				G. BROWN	12/12/05
	A	977/14	PRODUCTION ISSUE		G. SMITH	18/02/04	
	Issue	Mod No.	Alteration	Zone	Drawn by	Date	

No reproduction or publication of this drawing may be made and no article may be manufactured or assembled in accordance with this drawing without prior written consent. This prohibition is a term of any contract relating to this drawing. Rights reserved under the Copyright Act 1956 as amended by the Design Copyright Act 1988.

This part is common to the following units



Drawn	G. SMITH	Product	G2840/1/2 SINGLE PAN FRYER	
Date	18/02/04	Title	SPARES - OUTER PANELS	
Scale	N.T.S.	Drawing Number	BD42329	B
Matl.	_____	Issue		
No. off	_____	Finish	_____	_____
Bin No.	_____	Kraus No.	T111392	_____

UNCONTROLLED

1 2 3 4 5 6 7 8

IF IN DOUBT ASK!!

DO NOT SCALE !!
First Angle Projection

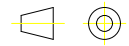

G2840/1/2 SINGLE PAN FRYER - CONTROLS

Part No.	Spares No.	Description
1	535770007	Phial Guard Mounting Bracket
2	535770008	Phial Guard Retaining Bracket
3	535770009	Phial Guard
4	535770069	Thermocouple
5	535770070	Safety Limit Device
6	535770071	Ferrite Bead
7	535770072	Boss Insulation Assembly

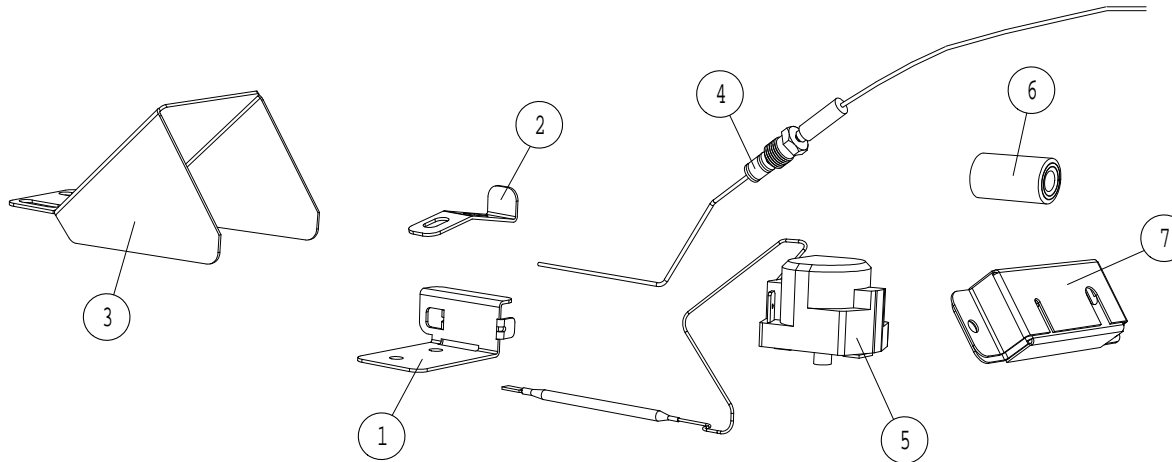

All Dimensions in millimetres, Tolerance \ 0.5mm (or as stated)

Drawn	G. SMITH	Product	G2840/1/2 SINGLE PAN FRYER	
Date	17/02/04	Title	SPARES - CONTROLS	
Scale	N.T.S.			

A	977/14	PRODUCTION ISSUE	G. SMITH	17/02/04	
Issue	Mod No.	Alteration	Zone	Drawn by	Date

UNCONTROLLED



This part is common to the following units

No reproduction or publication of this drawing may be made and no article may be manufactured or assembled in accordance with this drawing without prior written consent. This prohibition is a term of any contract relating to this drawing. Rights reserved under the Copyright Act 1956 as amended by the Design Copyright Act 1968.

Matl.	_____	Drawing Number	AD42326	Issue	A
No. off	_____	Finish	_____		
Bin No.	_____	Kraus No.	T111389		

IF IN DOUBT ASK!!

DO NOT SCALE !!

First Angle Projection

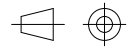

G2840/1/2 SINGLE PAN FRYER - ELECTRICS

Part No.	Spares No.	Description
1	535770061	Mains Cable c/w Plug
2	535770062	Mains Cable Cord Grip
3	535770063	Soft Start Mounting Plate
4	535770064	Stand Off (1 Off)
5	535770065	Electrics Cover Plate
6	535770066	Mains Terminal Block
7	535770067	Relay
8	535770068	Momentary Switch (1 Off)

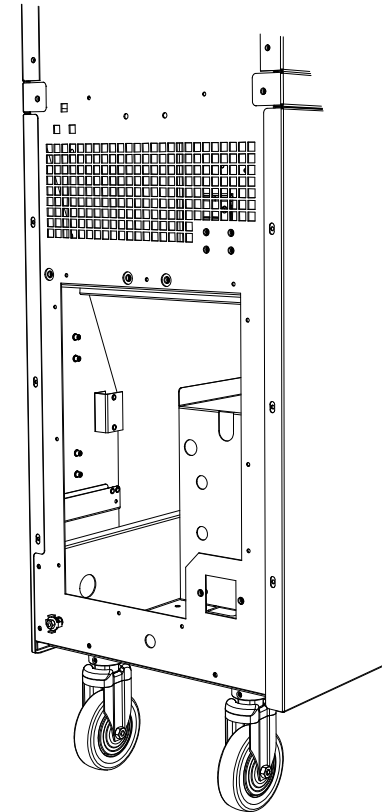
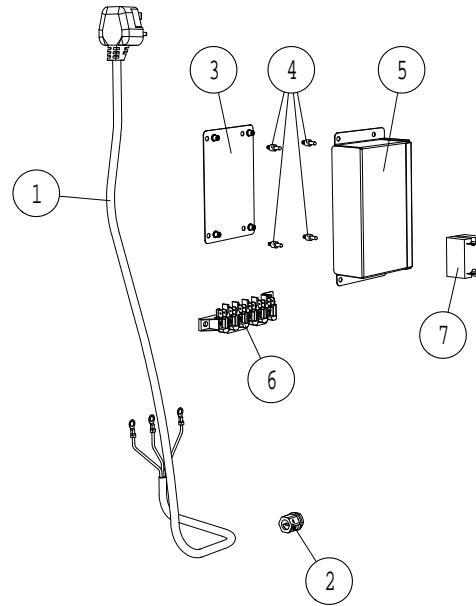
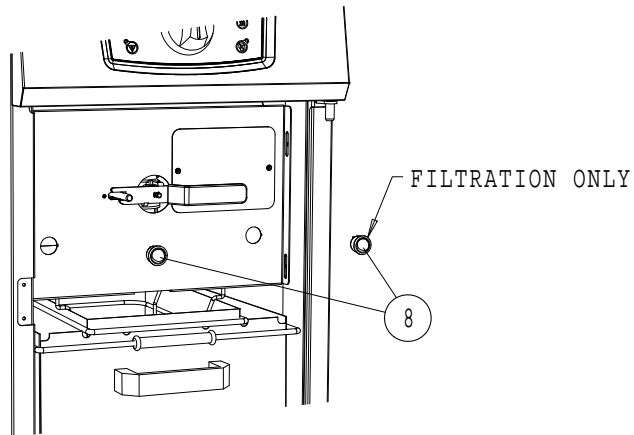

All Dimensions in millimetres, Tolerance \ 0.5mm (or as stated)

Drawn	G. SMITH	Product	G2840/1/2 SINGLE PAN FRYER	
Date	17/02/04	Title	SPARES - ELECTRICS	
Scale	N.T.S.			

A	977/14	PRODUCTION ISSUE	G. SMITH	17/02/04	
Issue	Mod No.	Alteration	Zone	Drawn by	Date

UNCONTROLLED

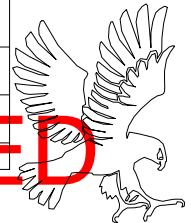

This part is common to the following units

© No reproduction or publication of this drawing may be made and no article may be manufactured or assembled in accordance with this drawing without prior written consent. This prohibition is a term of any contract relating to this drawing. Rights reserved under the Copyright Act 1956 as amended by the Design Copyright Act 1968.

Matl.		Drawing Number	Issue
No. off		AD42327	A
Bin No.		Kraus No. T111390	

IF IN DOUBT ASK!!

DO NOT SCALE !!
First Angle Projection

G2841/2 SINGLE PAN FRYER - BASKET LIFT

Part No.	Spares No.	Description
1	535780008	Basket Lift Motor
2	535780009	Basket Lift
3	535780011	Basket Lift Cover

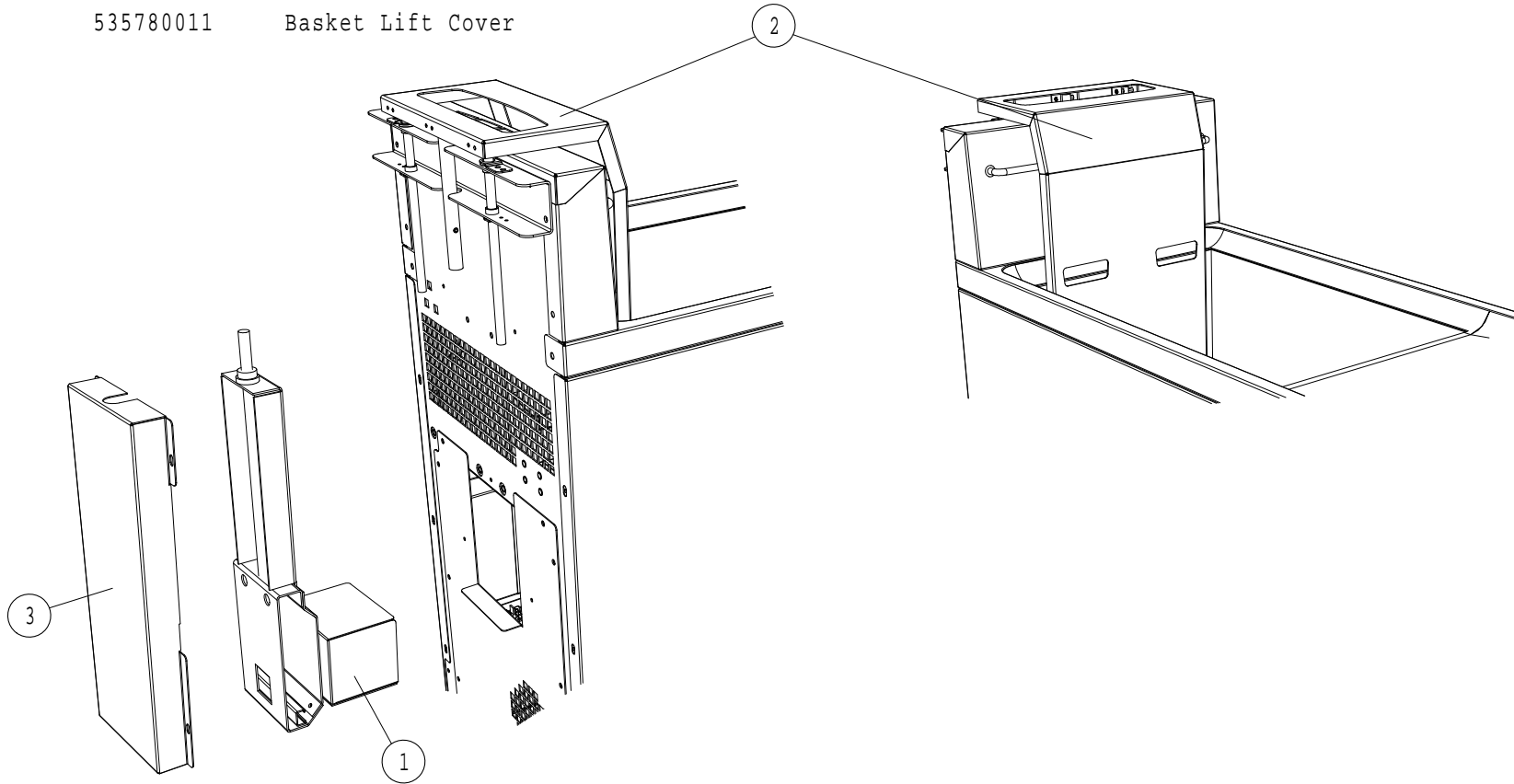

All Dimensions in millimetres, Tolerance \ 0.5mm (or as stated)

A		977/14	PRODUCTION ISSUE	G. SMITH	18/02/04	
Issue	Mod No.	Alteration	Zone	Drawn by	Date	
<p>No reproduction or publication of this drawing may be made and no article may be manufactured or assembled in accordance with this drawing without prior written consent. This prohibition is a term of any contract relating to this drawing. Rights reserved under the Copyright Act 1956 as amended by the Design Copyright Act 1968.</p>						<p>This part is common to the following units</p>
<p>©</p>						

Drawn	G. SMITH	Product	G2841/2 SINGLE PAN FRYER	
Date	18/02/04	Title	SPARES - BASKET LIFT	
Scale	N.T.S.	Matl.	_____	Drawing Number
No. off	_____	Finish	_____	Issue
Bin No.	_____	Kraus No.	T111395	AD42332
				A

IF IN DOUBT ASK!!

DO NOT SCALE !!

First Angle Projection

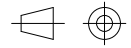

G2841 SINGLE PAN FRYER - CONTROL PANEL

Part No.	Spares No.	Description
1	535780002	Control Panel Assembly
2	535770054	Circular Spacer (1 Off)
3	535780005	Display Board FFE
4	535770064	Stand Off (1 Off)
5	535780004	Control Board PCB
6	535780003	Interface Board

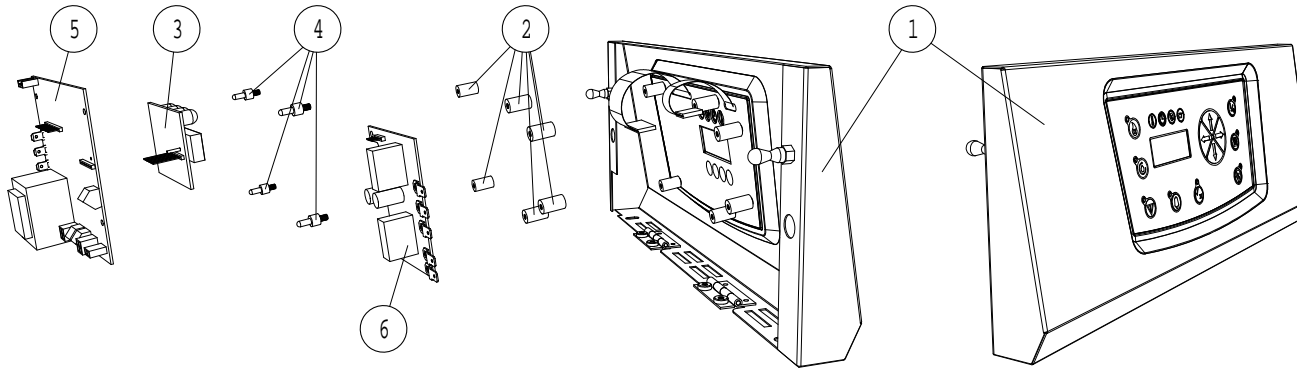

All Dimensions in millimetres, Tolerance \ 0.5mm (or as stated)

A					977/14 PRODUCTION ISSUE					G. SMITH 16/02/04																			
Issue					Mod No.					Alteration					Zone					Drawn by					Date				
<p>No reproduction or publication of this drawing may be made and no article may be manufactured or assembled in accordance with this drawing without prior written consent. This prohibition is a term of any contract relating to this drawing. Rights reserved under the Copyright Act 1956 as amended by the Design Copyright Act 1968.</p>																													
<p>This part is common to the following units</p>																													

Drawn		G. SMITH		Product		G2841 SINGLE PAN FRYER					
Date		16/02/04		Title		SPARES - CONTROL PANEL					
Scale		N.T.S.		Matl.		_____		Drawing Number		Issue	
No. off		_____		Finish		_____		AD42321		A	
Bin No.		_____		Kraus No.		T111386					

IF IN DOUBT ASK!!

DO NOT SCALE !!
First Angle Projection

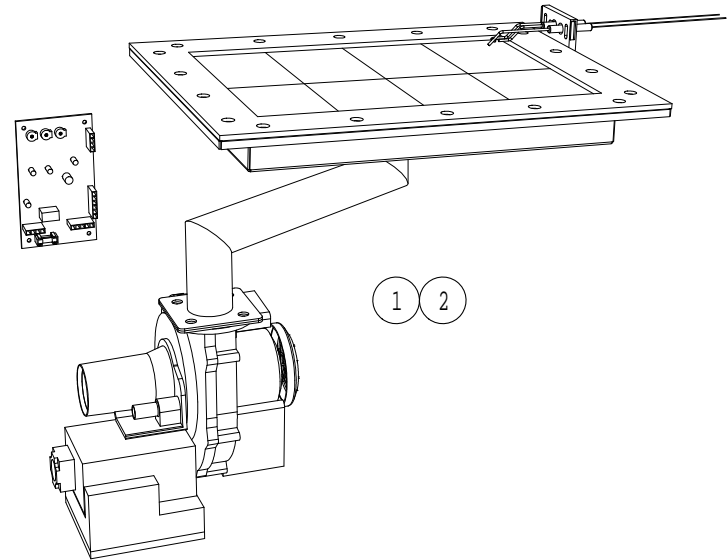
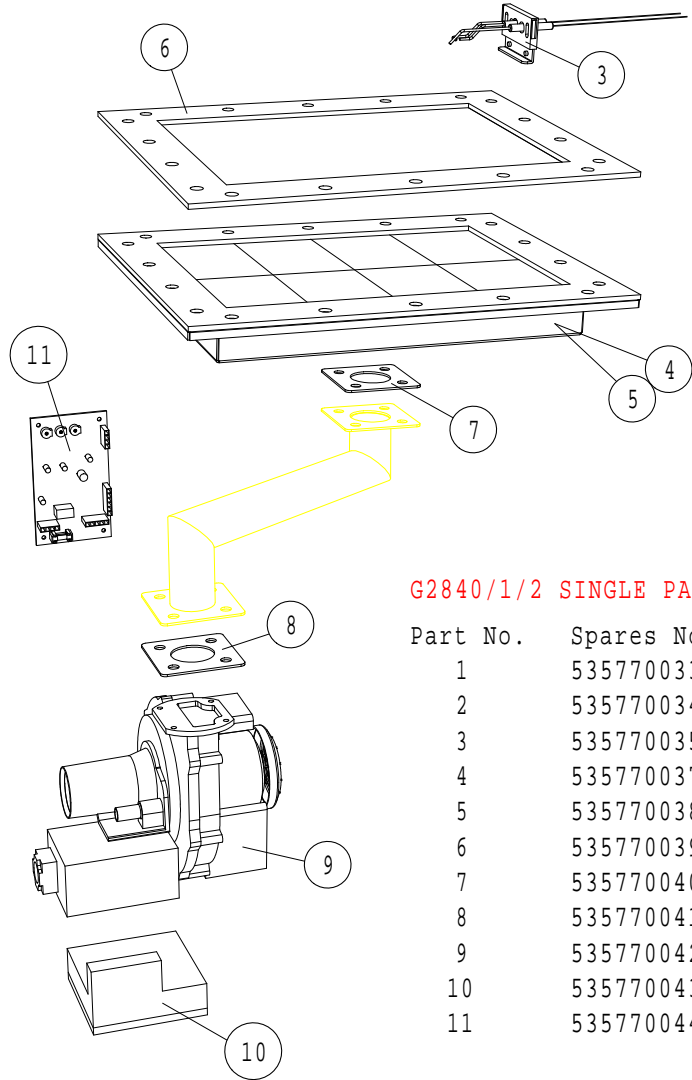
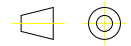

G2840/1/2 SINGLE PAN FRYER - BURNER SYSTEM

Part No.	Spares No.	Description
1	535770033	Burner Assembly (Nat Gas)
2	535770034	Burner Assembly (Propane)
3	535770035	Spark Electrode Assembly
4	535770037	Burner (Nat Gas)
5	535770038	Burner (Propane)
6	535770039	Burner Gasket
7	535770040	Burner To Pipe Gasket
8	535770041	Fan To Pipe Gasket
9	535770042	Fan Assembly
10	535770043	Control Box
11	535770044	Soft Start PCB

All Dimensions in millimetres, Tolerance \ 0.5mm (or as stated)

Drawn	G. SMITH	Product	G2840/1/2 SINGLE PAN FRYER	
Date	18/02/04	Title	SPARES - BURNER SYSTEM	
Scale	N.T.S.			
Matl.	_____	Drawing Number	AD42330	Issue
No. off	_____	Finish		A
Bin No.	_____	Kraus No.	T111394	

A 977/14 PRODUCTION ISSUE G. SMITH 18/02/04

Issue Mod No. Alteration Zone Drawn by Date

UNCONTROLLED
No reproduction or publication of this drawing may be made and no article may be manufactured or assembled in accordance with this drawing without prior written consent. This prohibition is a term of any contract relating to this drawing. Rights reserved under the Copyright Act 1956 as amended by the Design Copyright Act 1968.

This part is common to the following units

