



Applus®
LGAI
Organismo
Notificado
0370

AENOR
Organismo
Notificado
0099

FUNDADA EN 1878
MASBAGA
GRANDES COCINAS

EURAST

mac-fin

TOLERANCIAS GENERALES: ±0.5 mm

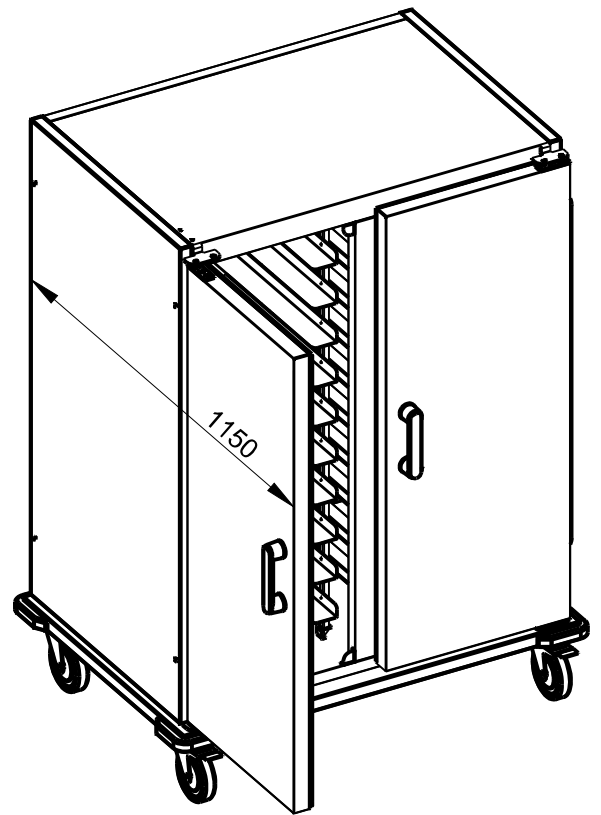
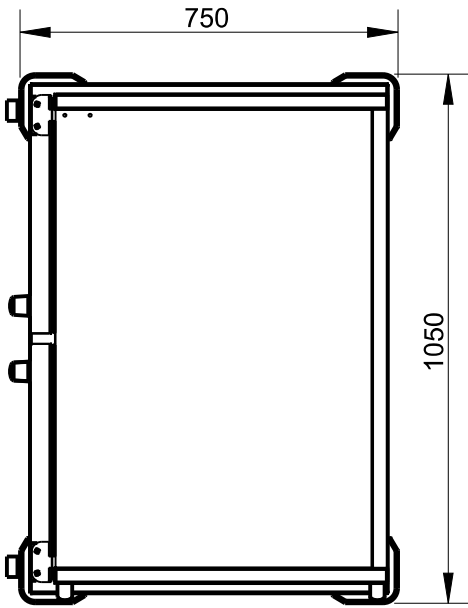
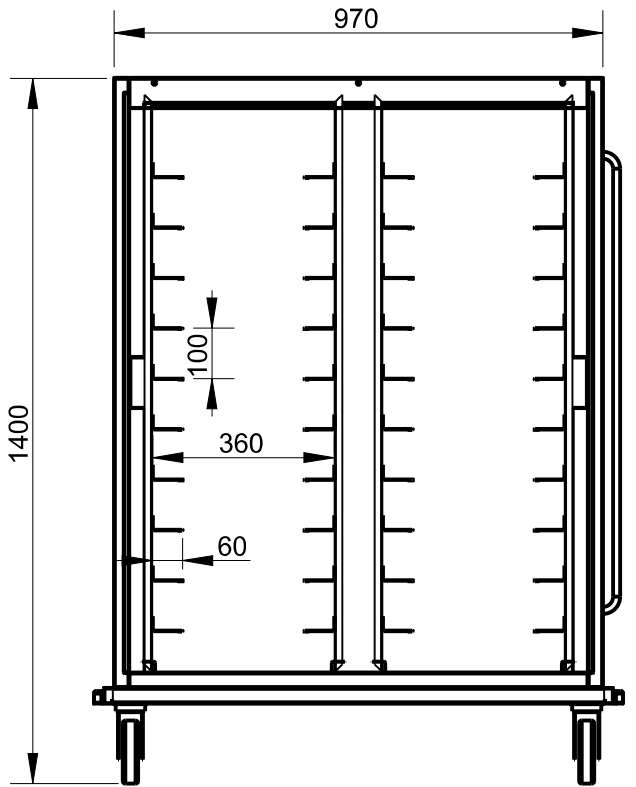
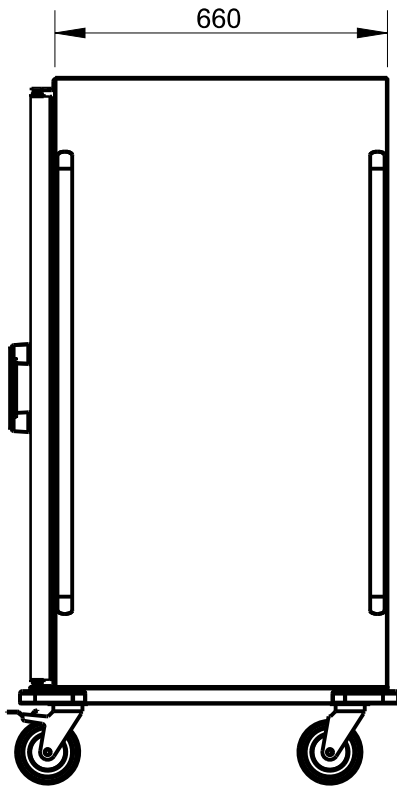

FAMILIA: NEUTRO

FECHA: 14/11/12

MODELO: 9002

PESO(Kg): 103.268

DENOMINACION:
ARM. ISOTERMO 1050X750X1400 10+10 BAND.

ESCALA:
1/15

MATERIAL:
INOX

CODIGO:
9002



Applus®
LGA1
Organismo
Notificado
0370

AENOR
Organismo
Notificado
0099



TOLERANCIAS GENERALES: ±0.5 mm

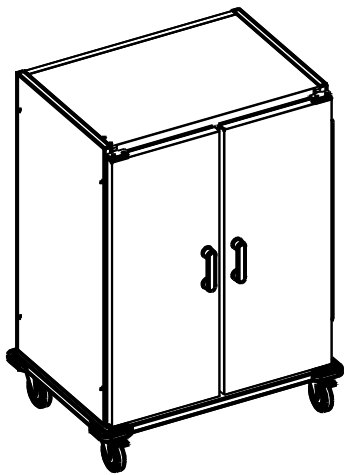

QT	COD	DESCRIPCION
1	900280	BASE ARMARIO
1	900263	BASE INTERIOR ARMARIO
4	6012	CANTONERA PLASTICO CARRO
4	900220C	CONJUNTO EMPARRILLADO
2	900205M	CONJUNTO PUERTA ARMARIO
1	900208	LATERAL DERECHO ARMARIO
2	900220	LATERAL INTERIOR
1	900209	LATERAL IZQ. ARMARIO
1	900273	MONTANTE CENTRAL
2	900204	OMEGA ARMARIO
2	900103P	PLETINA BISAGRA
2	706003P	PLETINA SUPERIOR BISAGRA
2	C6052	RUEDA D.125 CON FRENO
2	C6051	RUEDA D.125 SIN FRENO
4	900207	SEPARADOR EMPARRILLADO
8	706089	SOPORTE EMPARRILLADO AF
1	900272	TAPA MONTANTE CENTRAL
1	900201	TECHO ARMARIO
1	900202	TECHO INTERIOR ARMARIO
2	6518	TIRADOR PUERTA HORNO CHE
4	9001021	TOPE IMAN
1	900213	TRASERO ARMARIO
1	900264	TRASERO INTERIOR ARMARIO

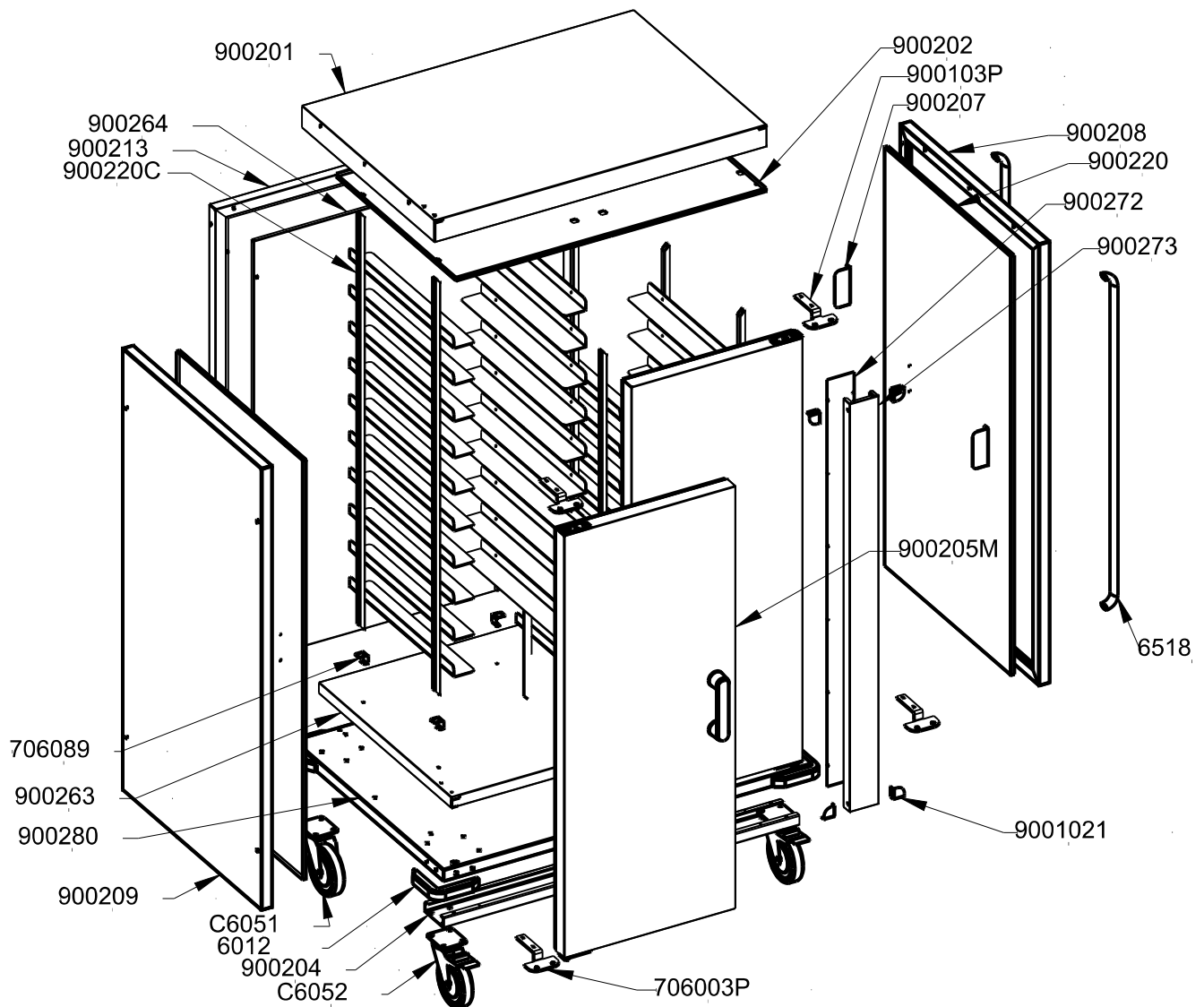

FAMILIA: NEUTRO

FECHA: 14/11/12

MODELO: 9002

PESO(Kg): 103.268

DENOMINACION:
ARM. ISOTERMO 1050X750X1400 10+10 BAND.

ESCALA:
1/15

MATERIAL:
INOX

CODIGO:
9002



Applus®
LGA1
Organismo
Notificado
0370

AENOR
Organismo
Notificado
0099



TOLERANCIAS GENERALES: ±0.5 mm

QT	COD	DESCRIPCION	FAB.	MATERIAL	DATA	PESO
1	900280	BASE ARMARIO	SÍ	i441 0.8	23/10/12	5.604
1	900263	BASE INTERIOR ARMARIO	SÍ	i441 0.8	23/10/12	4.381
4	900220C	CONJUNTO EMPARRILLADO	SÍ	INOX	23/10/12	4.608
2	900205M	CONJUNTO PUERTA ARMARIO	SÍ	INOX	31/10/12	8.926
2	900218	CONTRAPUERTA ARMARIO	SÍ	i441 0.8	31/10/12	3.341
40	900148	GUIA EMPARRILLADO	SÍ	i441 1.2	24/09/12	0.375
1	900208	LATERAL DERECHO ARMARIO	SÍ	i441 0.8	14/11/12	6.646
2	900220	LATERAL INTERIOR	SÍ	i441 0.8	23/10/12	4.491
1	900209	LATERAL IZQ. ARMARIO	SÍ	i441 0.8	23/10/12	6.646
1	900273	MONTANTE CENTRAL	SÍ	i441 0.8	23/10/12	1.064
2	900204	OMEGA ARMARIO	SÍ	GALVA 1.5	14/11/12	1.907
2	9001051	OMEGA REF.TIRADOR PUERTA	SÍ	i441 0.8	31/10/12	0.171
2	900205	PUERTA ARMARIO	SÍ	i441 0.8	31/10/12	4.517
4	900207	SEPARADOR EMPARRILLADO	SÍ	INOX 0.8	23/10/12	0.050
8	900269	SOPORTE EMPARRILLADO	SÍ	i441 1.2	23/10/12	0.430
8	706089	SOPORTE EMPARRILLADO AF	SÍ	i441 1.2	25/07/12	0.008
1	900272	TAPA MONTANTE CENTRAL	SÍ	i441 0.8	23/10/12	0.521
1	900201	TECHO ARMARIO	SÍ	i441 0.8	14/11/12	5.598
1	900202	TECHO INTERIOR ARMARIO	SÍ	i441 0.8	14/11/12	3.157
4	9001021	TOPE IMAN	SÍ	i441 0.8	19/10/12	0.009
1	900213	TRASERO ARMARIO	SÍ	i441 0.8	14/11/12	8.861
1	900264	TRASERO INTERIOR ARMARIO	SÍ	i441 0.8	14/11/12	6.314
4	C6262001	BISAGRA TORSION	NO	ZAMAK	13/03/09	0.190
4	6012	CANTONERA PLASTICO CARRO	NO	PLASTICO	24/09/12	0.300
4	6084	IMAN	NO	FE-INOX	01/01/01	0.021
2	900226	PERFIL PUERTA ARMARIO	NO	SILIC.ROJA	23/10/12	0.281
2	900103P	PLETINA BISAGRA	NO	FE 5 ZINC.	13/11/12	0.182
2	706003P	PLETINA SUPERIOR BISAGRA	NO	FE 5 ZINCADO	16/06/10	0.198
2	C6052	RUEDA D.125 CON FRENO	NO	ZN	24/09/12	0.756
2	C6051	RUEDA D.125 SIN FRENO	NO	ZN	24/09/12	0.810
2	70491019	TIRADOR CRISTAL ASADOR	NO	BAQ	01/01/01	0.195
2	6518	TIRADOR PUERTA HORNO CHE	NO	INOX 29 X 14	14/05/04	0.642



FAMILIA: NEUTRO

FECHA: 14/11/12

MODELO: 9002

PESO(Kg): 103.268

DENOMINACION:
ARM. ISOTERMO 1050X750X1400 10+10 BAND.

ESCALA:
1/15

MATERIAL:
INOX

CODIGO:
9002



Applus®
LGA1
Organismo
Notificado
0370

AENOR
Organismo
Notificado
0099



TOLERANCIAS GENERALES: ±0.5 mm

QT	COD	DESCRIPCION
2	C6262001	BISAGRA TORSION
1	900218	CONTRAPUERTA ARMARIO
2	6084	IMAN
1	9001051	OMEGA REF.TIRADOR PUERTA
1	900226	PERFIL PUERTA ARMARIO
1	900205	PUERTA ARMARIO
1	70491019	TIRADOR CRISTAL ASADOR

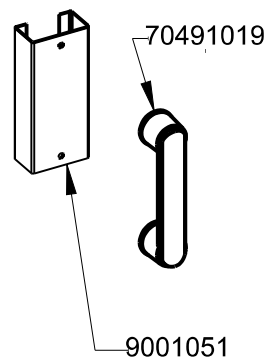
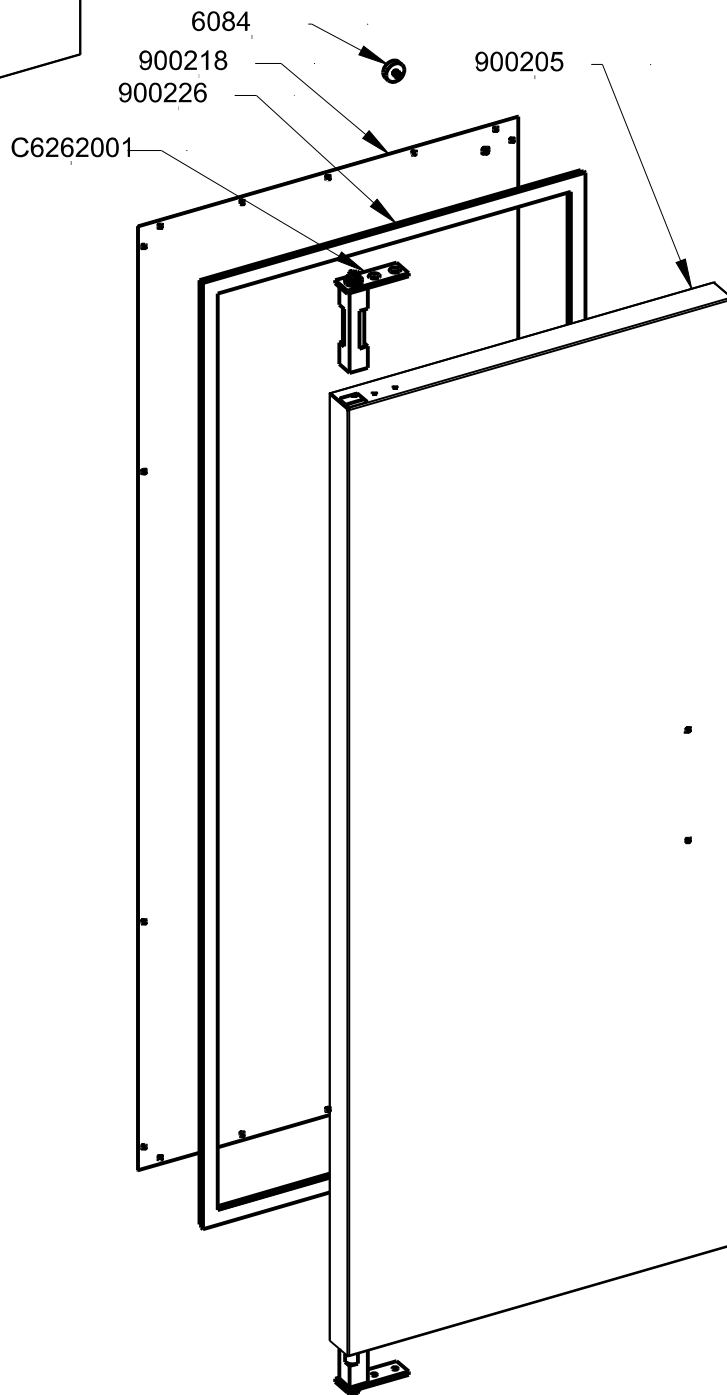
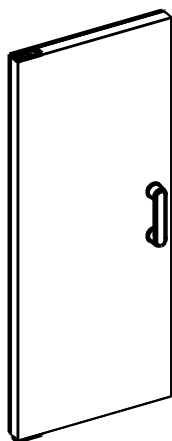

FAMILIA: NEUTRO

FECHA: 31/10/12

MODELO: 9002

PESO(Kg): 8.926

DENOMINACION:
CONJUNTO PUERTA ARMARIO

ESCALA:
28/225

MATERIAL:
INOX

CODIGO:
900205M



Applus[®]
LGA I
Organismo
Notificado
0370

AENOR
Organismo
Notificado
0099



TOLERANCIAS GENERALES: ±0.5 mm

QT	COD	DESCRIPCION	FAB.	MATERIAL	DATA	PESO
1	900218	CONTRAPUERTA ARMARIO	SÍ	i441 0.8	31/10/12	3.341
1	9001051	OMEGA REF.TIRADOR PUERTA	SÍ	i441 0.8	31/10/12	0.171
1	900205	PUERTA ARMARIO	SÍ	i441 0.8	31/10/12	4.517
2	C6262001	BISAGRA TORSION	NO	ZAMAK	13/03/09	0.190
2	6084	IMAN	NO	FE-INOX	01/01/01	0.021
1	900226	PERFIL PUERTA ARMARIO	NO	SILIC.ROJA	23/10/12	0.281
1	70491019	TIRADOR CRISTAL ASADOR	NO	BAQ	01/01/01	0.195



FAMILIA: NEUTRO

FECHA: 31/10/12

MODELO: 9002

PESO(Kg): 8.926

DENOMINACION:
CONJUNTO PUERTA ARMARIO

ESCALA:
11/225

MATERIAL:
INOX

CODIGO:
900205M