

DESPIECE TECNICO
LISTE DE PIÈCES DÉTACHÉES
SPARE PARTS LIST

Septiembre - 1997

**MARMITAS
MARMITES
BOILING PANS**

Modelos:

ME-910 BM

ME-915 BM



Proyectos e Instalaciones y S.A.T.
Oñati, 8 de Octubre de 1997

Hostelería, Frío Comercial y Lavandería Industrial
Grandes Cuisines, Froid Commercial et Buanderie
Catering, Commercial Refrigeration and Laundry Equipment

Fagor Industrial, S. Coop.
20560 - Oñati - España



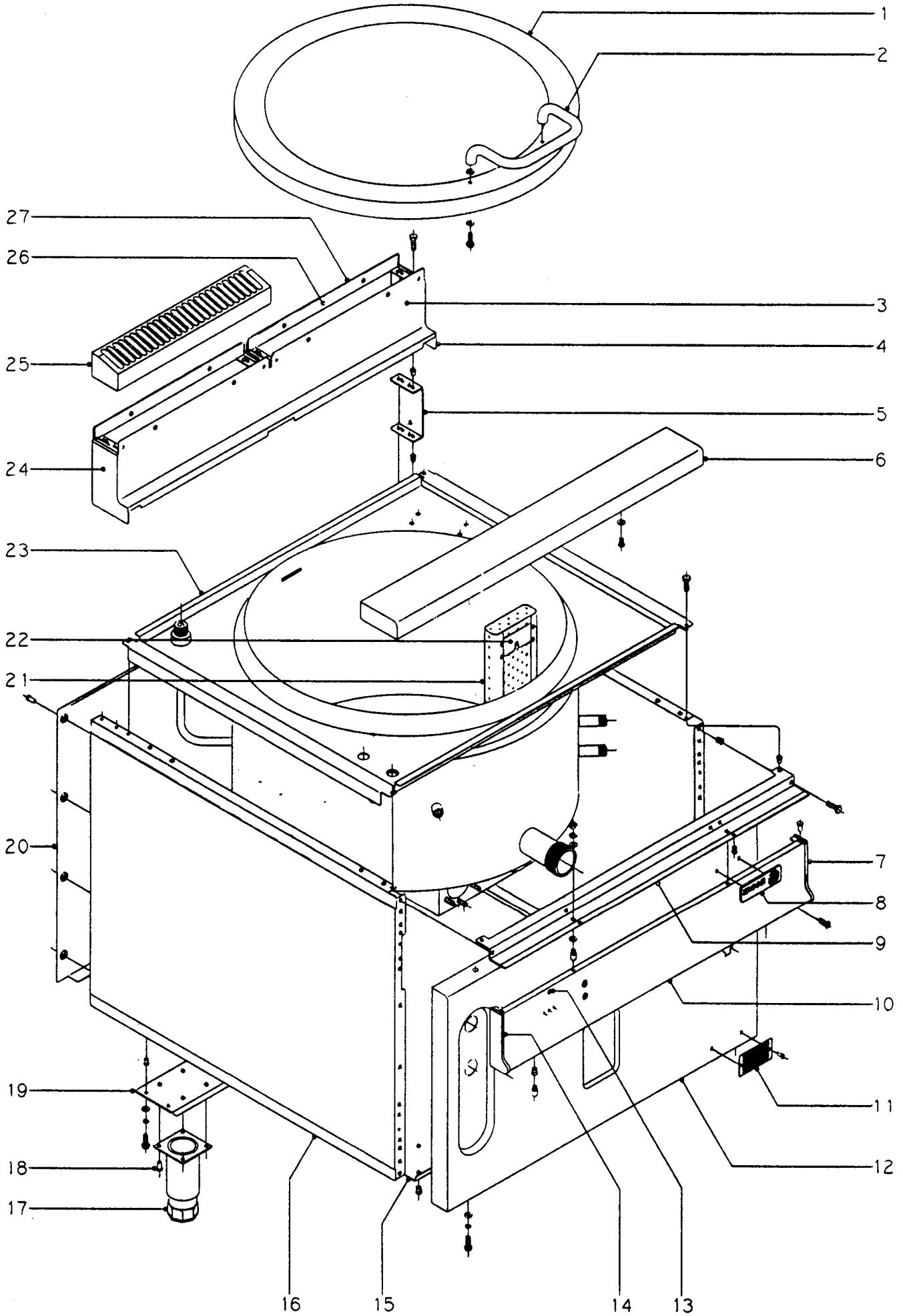

N plano C-499	Firma <i>[Signature]</i>	Fecha 9-97	Aparato MARMITAS ME-910-BM, ME-915-BM	Lamina 1	Fagor Industrial S. Coop. FAGOR Ortiz
------------------	-----------------------------	---------------	--	-------------	---

CONCEPTO: MUEBLE EXTERIOR SUJET: PIECES EXTERIEURES CONCEPT: EXTERNAL PARTS					LAMINAN° VUE N° 1 ILUSTR. N.		PLANON° PLAN N° C-499 DRAWINGN.			PAGINAN° PAGEN° 2 PAGEN.	
APARATO - APPAREIL - APPLIANCE: MARMITA - MARMITE - BOILING PAN					MODELO Y CANTIDAD - MOD. ET QUANT. - MOD. & QUANT.					OBSERVACIONES	
N°	CODIGO	DENOMINACION	DENOMINATION	DESCRIPTION	ME-910 BM	ME-915 BM					
1	S036136	Tapa	Couvercle	Lid	1	1					
2	S036123	Asa de tapa	Poignée du couvercle	Lid handle	1	1					
	Q306048	Arandela junta Ø19xØ8,5x1	Rondelle Ø19xØ8,5x1	Washer Ø19xØ8,5x1	2	2					
	Q232050	Arandela plana A.8	Rondelle plate A.8	Flat washer A.8	2	2					
	Q012053	Tornillo exagonal M.8x20	Vis hexagonal M.8x20	Hexagonal bolt M.8x20	2	2					
3	U585406	Anterior suplemento 1M.	Anterieur suplement	Frontal supplement1	1						
4	R205407	Lateral derecho suplemento	Lateral droite suplement	Right side supplement	1	1					
	Q162020	Tuerca exagonal M.4	Ecrou M.4	Nut M.4	2	2					
	Q012031	Tornillo exagonal M.5x10	Vis M.5x10	Screw M.5x10	4	4					
5	R205409	Escuadra	Equerre	Plate	2	2					
	Q221342	Remache exagonal M.5	Rivet hexagonal M.5	Hexagonal rivet M.5	4	4					
	Q012031	Tornillo exagonal M.5x10	Vis M.5x10	Screw M.5x10	4	4					
6	R205401	Anterior de mesa	Anterieur de table	Front of table	1	1					
	Q302022	Arandela plana Ø16xØ6x1,2	Rondelle Ø16xØ6x1,2	Washer Ø16xØ6x1,2	2	2					
	Q152004	Tornillo aplastado M.5x13	Vis M.5x13	Screw M.5x13	2	2					
7	U262809	Cantonera derecha portamandos	Cantonière droite pann.comman.	Curb bar-right	1	1					
	Q419005	Remache tubular Ø4x8	Rivet Ø4x8	Rivet Ø4x8	2	2					
8	R202899	Escudo FAGOR	Emblème FAGOR	FAGOR emblem	1	1					
	Q221023	Clips sujeción escudo	Fixation emblème	Emblem fastening	2	2					
9	R202601	Escuadra fijación portamandos	Equerre fixation pann.comman.	Fastening plate	1	1					
	Q151336	Tornillo soporte guía portam.	Vis support guide pann.comm.	Screw	2	2					
	Q302022	Arandela plana Ø16xØ6x1,2	Rondelle Ø16xØ6x1,2	Washer Ø16xØ6x1,2	4	4					
	Q262040	Arandela muelle A.6	Rondelle A.6	Washer A.6	2	2					
	Q162040	Tuerca exagonal M.6	Ecrou M.6	Nut M.6	2	2					
	Q221342	Remache exagonal M.5	Rivet M.5	Rivet M.5	2	2					
	Q012031	Tornillo exagonal M.5x10	Vis M.5x10	Screw M.5x10	2	2					
10	S092801	Panel portamandos	Panneau de commande	Control panel	1	1					
	Q221343	Remache exagonal M.6	Rivet M.6	Rivet M.6	2	2					
	Q151336	Tornillo soporte guía	Vis support guide	Screw	2	2					
	Q152004	Tornillo aplastado M.5x13	Vis M.5x13	Screw M.5x13	2	2					
11	Z206121	Placa matrícula	Plaque d'identification	Identification plate	1	1					
	Q419005	Remache tubular Ø4x8	Rivet Ø4x8	Rivet Ø4x8	2	2					

CONCEPTO: MUEBLE EXTERIOR SUJET: PIECES EXTERIEURES CONCEPT: EXTERNAL PARTS					LAMINAN° VUE N° 1 ILUSTR. N.		PLANON° PLAN N° C-499 DRAWINGN.			PAGINAN° PAGEN° 3 PAGEN.	
APARATO - APPAREIL - APPLIANCE: MARMITA - MARMITE - BOILING PAN					MODELO Y CANTIDAD - MOD. ET QUANT. - MOD. & QUANT.					OBSERVACIONES	
N°	CODIGO	DENOMINACION	DENOMINATION	DESCRIPTION	ME-910 BM	ME-915 BM					
12	S082800	Panel frontal	Panneau frontal	Frontal panel	1	-					
12	S092800	Panel frontal	Panneau frontal	Frontal panel	-	1					
	Q302022	Arandela plana Ø16xØ6x1,2	Rondelle Ø16xØ6x1,2	Washer Ø16xØ6x1,2	2	2					
	Q262040	Arandela muelle A.6	Rondelle A.6	Washer A.6	2	2					
	Q012042	Tornillo exagonal M.6x15	Vis hexagonal M.6x15	Hexagonal bolt M.6x15	2	2					
13	U562806	Indicador posición "0"	Indicateur de position "0"	"Off" indicator	1	1					
	Q221026	Clips sujeción indicador	Fixation voyant	Indicator fastening	1	1					
14	U262810	Cantonera izda. portamandos	Cantonière gauche	Control panel curb bar-left	1	1					
	Q419005	Remache tubular Ø4x8	Rivet Ø4x8	Rivet Ø4x8	2	2					
15	S092630	Base cubre-aguas	Base	Base	1	1					
16	R202800	Panel lateral	Panneau latéral	Side panel	2	2					
	Q221343	Remache exagonal M.6	Rivet M.6	Rivet M.6	8	8					
	Q302022	Arandela plana Ø16xØ6x1,2	Rondelle Ø16xØ6x1,2	Washer Ø16xØ6x1,2	8	8					
	Q262040	Arandela muelle A.6	Rondelle A.6	Washer A.6	8	8					
	Q012042	Tornillo exagonal M.6x15	Vis hexagonal M.6x15	Hexagonal bolt M.6x15	8	8					
17	X260150	Pata regulable	Pied réglable	Adjustable foot	4	4					
18	Q411304	Remache avibulb Ø4x8	Rivet Ø4x8	Rivet Ø4x8	16	16					
19	R202640	Listón soporte patas 1 M.	Support pour pieds - 1 Mod.	Legs support - 1 Mod.	2	2					
20	R202801	Panel posterior	Panneau posterieur	Rear panel	1	1					
	Q419005	Remache tubular Ø4x8	Rivet Ø4x8	Rivet Ø4x8	10	10					
21	S016120	Filtro de cuba	Filtre de cuve	Filter of pan	1	-					
21	S036126	Filtro de cuba	Filtre de cuve	Filter of pan	-	1					
22	S036117	Soporte filtro	Support	Support	2	2					
	Q412000	Remache tubular Ø4x8	Rivet Ø4x8	Rivet Ø4x8	8	8					
23	S086101	Cuba	Cuve	Pan	1	-					
23	S096101	Cuba	Cuve	Pan	-	1					
	Q012031	Tornillo exagonal M.5x10	Vis M.5x10	Screw M.5x10	4	4					
	Q221342	Remache exagonal M.5	Rivet M.5	Rivet M.5	4	4					
24	R205408	Lateral izquierdo suplemento	Lateral gauche supplement	Left side supplement	1	1					
25	R205410	Embellecedor de chimenea	Garniture bouche de fumée	Shaft adornment	2	2					
26	R205406	Fijación central simple	Fixation central simple	Single central fastening	2	2					
27	R205405	Posterior suplemento 1M.	Posterieur supplément 1M.	Rear supplement 1M.	1	1					

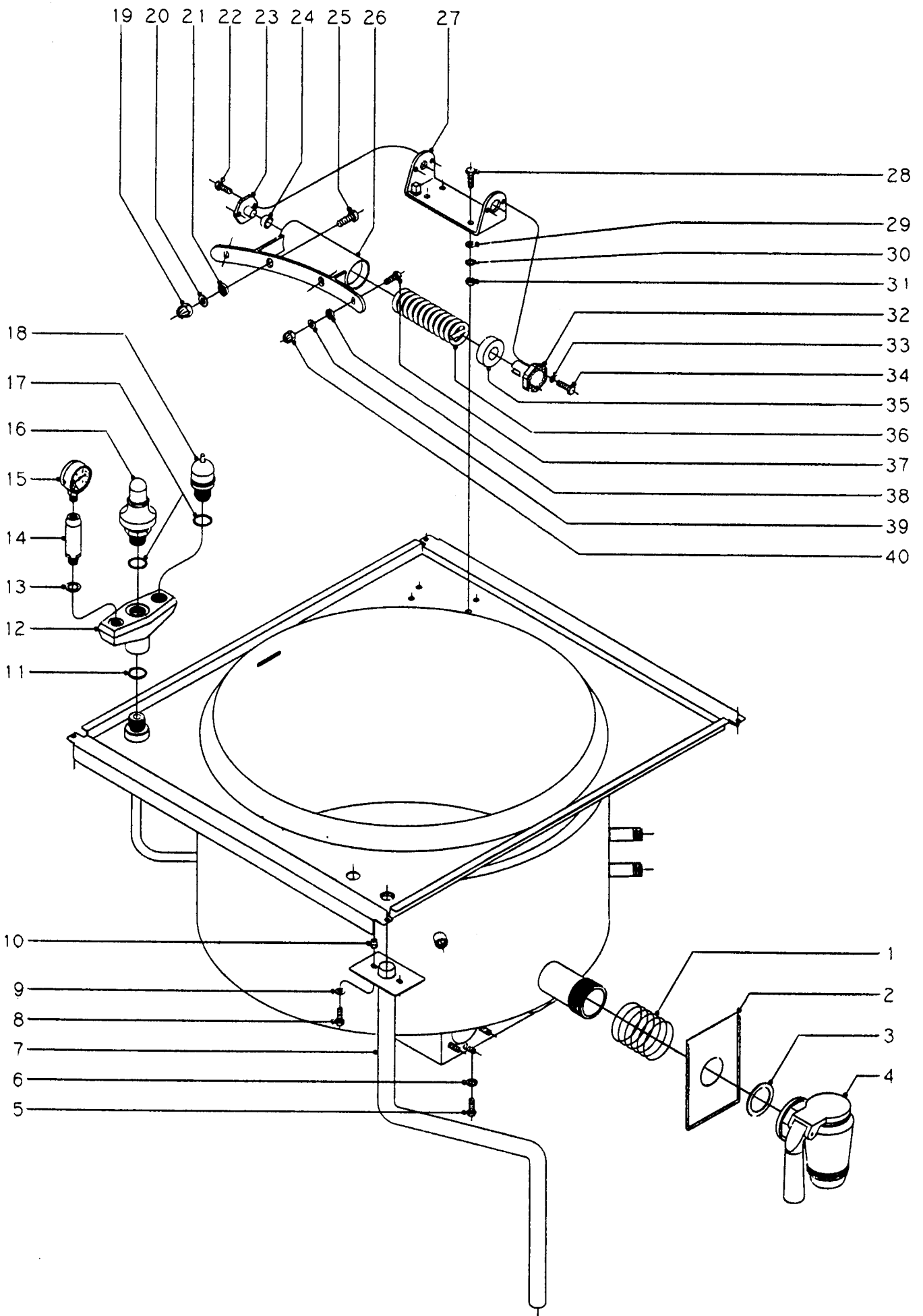

N plano	Firma	Fecha	Aparato	Lamina	Fagor Industrial S.Coop	FAGOR
C-500		9-97	MARMITAS ME-910-BM, ME-915-BM	2	Oficis	

CONCEPTO: DESAGÜES, VÁLVULA Y BISAGRA TAPA SUJET: VIDANGE, SOUPAPE ET CHARNIERE CONCEPT: DRAIN, VALVE AND HINGE					LAMINANº VUE Nº 2 ILUSTR. N.		PLANONº PLAN Nº C-500 DRAWINGN.			PAGINANº PAGENº 5 PAGEN.	
APARATO-APPAREIL -APPLIANCE: MARMITA - MARMITE - BOILING PAN					MODELO Y CANTIDAD - MOD. ET QUANT. - MOD. & QUANT.					OBSERVACIONES	
Nº	CODIGO	DENOMINACION	DENOMINATION	DESCRIPTION	ME-910 BM	ME-915 BM					
1	S112105	Muelle soporte cubierta	Ressort	Spring	1	1					
2	S112803	Cubierta de grifo	Couverture du robinet	Cock plate	1	1					
3	S112152	Junta grifo vaciado	Joint	Seal	1	1					
4	S112150	Grifo de vaciado	Vanne de vidange	Drain tap	1	1					
5	Q012063	Tornillo tapón M.10x20	Vis M.10x20	Bolt M.10x20	1	1					
6	Q309003	Junta de cobre Ø18xØ11x2	Joint Ø18xØ11x2	Joint Ø18xØ11x2	1	1					
7	S036119	Tubo vaciado	Conduite de vidange	Drain pipe	1	1					
8	Q012032	Tornillo exagonal M.5x15	Vis M.5x15	Bolt M.5x15	2	2					
9	Q232030	Arandela plana A.5	Rondelle A.5	Washer A.5	2	2					
10	Q221342	Remache exagonal M.5	Rivet M.5	Rivet M.5	2	2					
11	Q306049	Arandela junta Ø31xØ26,5x1	Rondelle joint Ø31xØ26,5x1	Joint washer Ø31xØ26,5x1	1	1					
12	S022100	Soporte tres salidas	Support trois sorties	Support	1	1					
13	Q306039	Arandela junta Ø25xØ16,5x1,5	Rondelle joint Ø25xØ16,5x1,5	Joint washer Ø25xØ16,5x1,5	1	1					
14	S022102	Sifón portamanómetro	Siphon	Siphon	1	1					
15	9220815	Manómetro de 0 a 1 kg/cm²	Manomètre de 0 à 1 Kg/cm²	Manometer, 0-1 Kg/cm²	1	1					
16	S022101	Válvula de seguridad	Soupape de sécurité	Safety valve	1	1					
17	Q306049	Arandela junta Ø 31xØ26,5x1	Rondelle joint Ø 31xØ26,5x1	Joint washer Ø 31xØ26,5x1	2	2					
18	S022103	Válvula presión	Soupape	Valve	1	1					
19	Q212051	Tuerca sombrerete M.8	Ecrou à chapeau M.8	Cap nut M.8	2	2					
20	Q232050	Arandela plana A.8	Rondelle plate A.8	Flat washer A.8	2	2					
21	Q308000	Arandela dubo A.8	Rondelle A.8	Washer A.8	2	2					
22	Q012041	Tornillo exagonal M.6x10	Vis hexagonal M.6x10	Hexagonal screw M.6x10	2	2					
23	S116119	Giro de asa	Dispositif pivotage poignée	Handle rotation	1	1					
24	S116126	Cojinete cilíndrico	Coussinet cylindrique	Cylindrical bearing	1	1					
25	Q012052	Tornillo exagonal M.8x15	Vis hexagonal M.8x15	Hexagonal screw M.8x15	2	2					
26	S036130	Bisagra	Charnière	Hinge	1	1					
27	S036131	Soporte de bisagra	Support de charnière	Hinge support	1	1					
28	Q012055	Tornillo exagonal M.8x30	Vis hexagonal M.8x30	Hexagonal screw M.8x30	4	4					
29	Q232050	Arandela plana A.8	Rondelle plate A.8	Flat washer A.8	4	4					
30	Q262050	Arandela muelle A.8	Rondelle à ressort A.8	Spring washer A.8	4	4					
31	Q162050	Tuerca exagonal M.8	Ecrou hexagonal M.8	Hexagonal nut M.8	4	4					
32	S116120	Tensor resorte	Tendeur ressort	Spring sleeve nut	1	1					

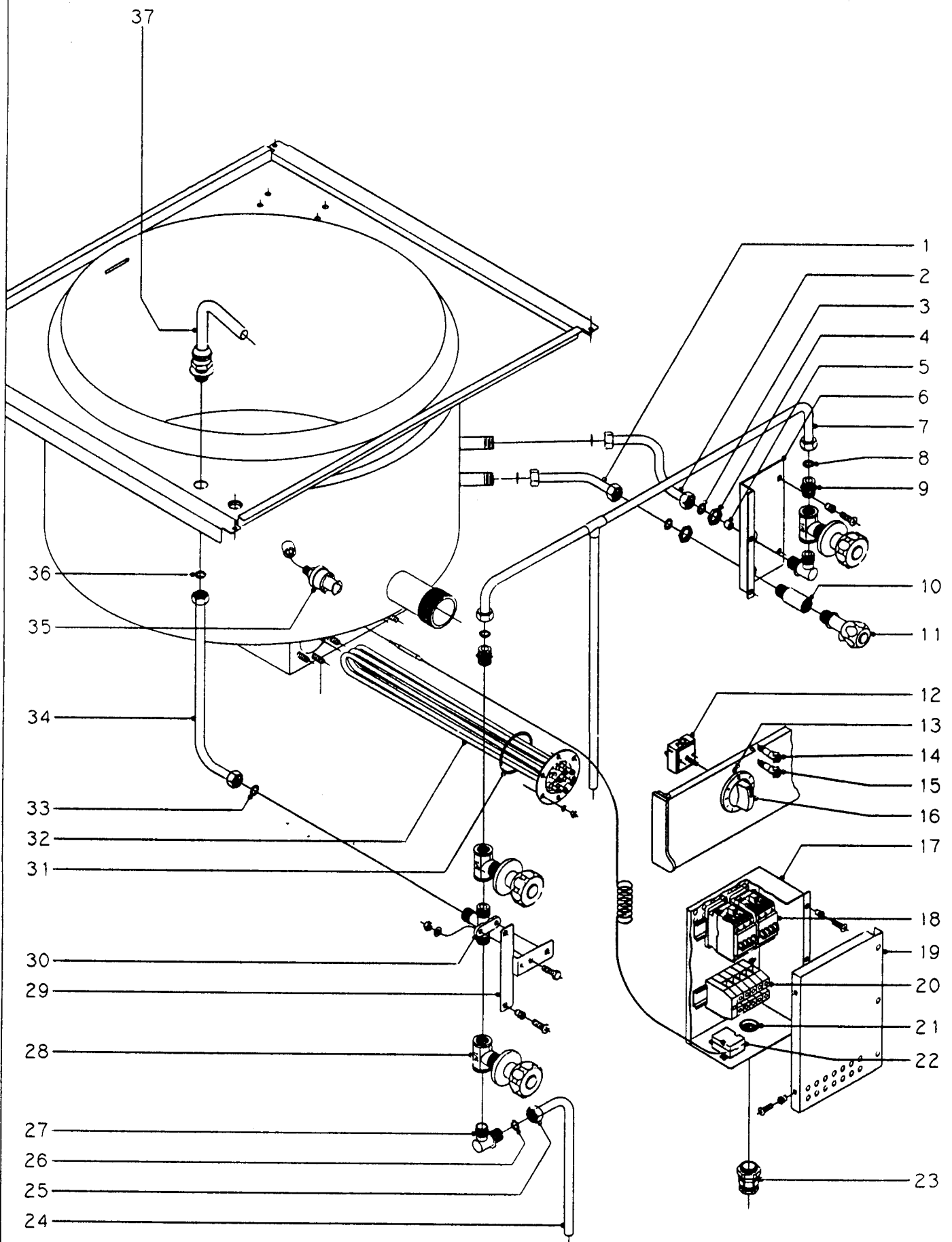

N plano	Firma	Fecha	Aparato	Lamina	Fagor Industrial S.Coop. FAGOR
C-501	<i>[Signature]</i>	9-97	MARMITAS ME-910-BM, ME-915-BM	3	Onote

CONCEPTO: PARTE ELECTRICA Y TOMAS DE AGUA SUJET: PIECES ELECTRIQUES ET PRISES D'EAU CONCEPT: ELECTRICAL COMPONENTS AND WATER INLET					LAMINAN° VUE N° 3 ILUSTR. N.		PLANON° PLAN N° C-501 DRAWINGN.			PAGINAN° PAGEN° 8 PAGEN.	
APARATO - APPAREIL - APPLIANCE: MARMITA - MARMITE - BOILING PAN					MODELO Y CANTIDAD - MOD. ET QUANT. - MOD. & QUANT.					OBSERVACIONES	
N°	CODIGO	DENOMINACION	DENOMINATION	DESCRIPTION	ME-910 BM	ME-915 BM					
1	S025006	Conducción nivel B.M.	Conduit à niveau B.M.	Pipe to B.M. level	1	-					
1	S045004	Conducción nivel B.M.	Conduit à niveau B.M.	Pipe to B.M. level	-	1					
2	S025006	Conducción llenado B.M.	Conduit remplissage B.M.	Filling pipe	1	-					
2	S025002	Conducción llenado B.M.	Conduit remplissage B.M.	Filling pipe	-	1					
3	Q306024	Arandela junta Ø 18xØ12,5x1,5	Rondelle joint Ø 18xØ12,5x1,5	Joint washer Ø 18xØ12,5x1,5	4	4					
4	Q221401	Tuerca exagonal 1/2"	Ecrou 1/2"	Nut 1/2"	2	2					
5	S225012	Regulador de caudal	Regulateur de débit	Flow regulator	1	1					
6	S092601	Soporte grifos y caja electr.	Support robinets	Cocks support	1	1					
	Q221342	Remache exagonal M.5	Rivet M.5	Rivet M.5	2	2					
	Q152004	Tornillo aplastado M.5x13	Vis M.5x13	Bolt M.5x13	3	3					
7	S095000	Conducción agua caliente (superior)	Conduit d'eau chaude	Hot water pipe	1	1					
8	Q306024	Arandela junta Ø 18xØ12,5x1,5	Rondelle joint Ø 18xØ12,5x1,5	Joint washer Ø 18xØ12,5x1,5	2	2					
9	S205023	Manguito 1/2" - 1/2"	Douille 1/2" - 1/2"	Sleeve 1/2" - 1/2"	2	2					
10	S045006	Casquillo grifo nivel	Douille du robinet	Level cock sleeve	1	1					
11	S022104	Grifo nivel	Robinet de niveau	Level cock	1	1					
12	S333001	Regulador de energía	Regulateur d'energie	Energy regulator	1	1					
13	U562806	Indicador de posición "0"	Indicateur de position "0"	"Off" indicator	1	1					
s/n	Q221026	Clips sujeción indicador	Clips fixation	Fastening clip	1	1					
14	Z203004	Piloto verde	Témoin vert	Green light	1	1					
15	Z203005	Piloto ámbar	Témoin jaune	Yellow light	1	1					
16	S333005	Botón de mando Ø 6	Bouton de commande Ø 6	Control button Ø 6	1	1					
17	S093008	Caja eléctrica	Boite électrique	Electrical box	1	1					
	Q221342	Remache exagonal M.5	Rivet M.5	Rivet M.5	2	2					
	Q152004	Tornillo aplastado M.5x13	Vis M.5x13	Bolt M.5x13	2	2					
18	X183011	Contactador 3TF3200-0 AL 2	Contacteur	Switch	2	2					
	Z103084	Guía L=138	Guide L=138	Guide L=138	1	1					
19	S093010	Tapa caja eléctrica	Couvercle de boite	Box cover	1	1					
	Q221342	Remache exagonal M.5	Rivet M.5	Rivet M.5	2	2					
	Q152004	Tornillo aplastado M.5x13	Vis M.5x13	Bolt M.5x13	3	3					
20	Z683069	Borna fases (gris)	Connexion pour phase (gris)	Phase connection (grey)	3	3					
	Z683097	Borna neutro (azul)	Connexion pour neutre (bleu)	Neutral connection (blue)	1	1					
	Z683070	Borna tierra (verde-amarillo)	Connexion terre (vert-jaune)	Earth connection (green-yellow)	1	1					

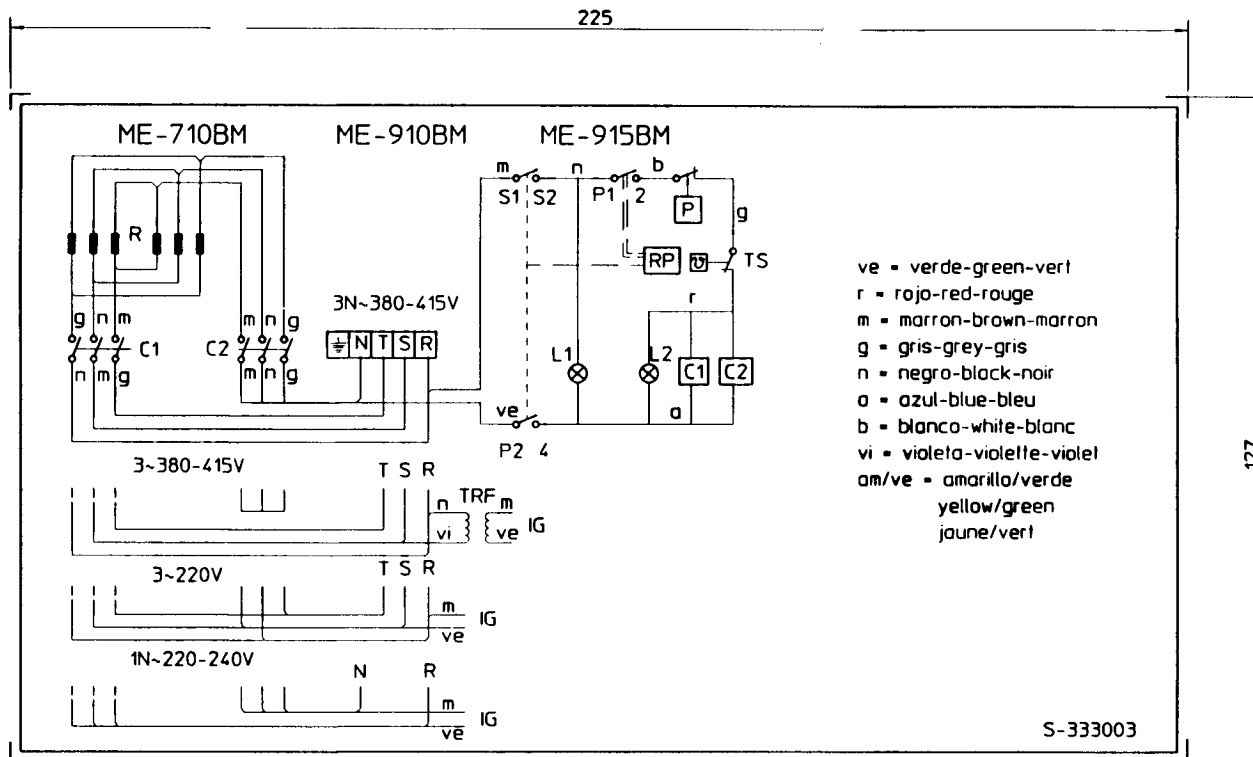

NOTA

- Las inscripciones resistirán sin modificación apreciable el frotamiento durante 15 seg de un algodón impregnado en gasolina.

- IG: Interruptor general
- L1: Lámpara funcionamiento
- RP: Regulador de energía.
- L2: Lámpara calentamiento
- C1,C2: Contactor de calentamiento
- R: Resistencias
- P: Presostato (0,3 bar.)
- TS: Termostato Seguridad (125°)
- TRF: Transformador

Plástico blanco alto brillo

Esquema teorico adhesivo			S-333003	
Nº	Pieza	Material	Nº Clasificación	Acabado
Nº	Modificación	Propuesta de	Fecha	Tolerancias generadas
				< 5% 50-100%
				5-75% > 100%
				75-90% X
Dibujado		Firma	Fecha	Mecanizado superficial
Proyectado		KONTXI	20/6/97	
Comprobado		<i>de la...</i>		
Escala				
FAGOR			Fagor Industrial, Koop Elk. Mugatua	
MARMITA ELECTRICA				Plano numero
				HC-72844
				Sustituye al Nº
				Sustituido por