

**ES elettrobar**

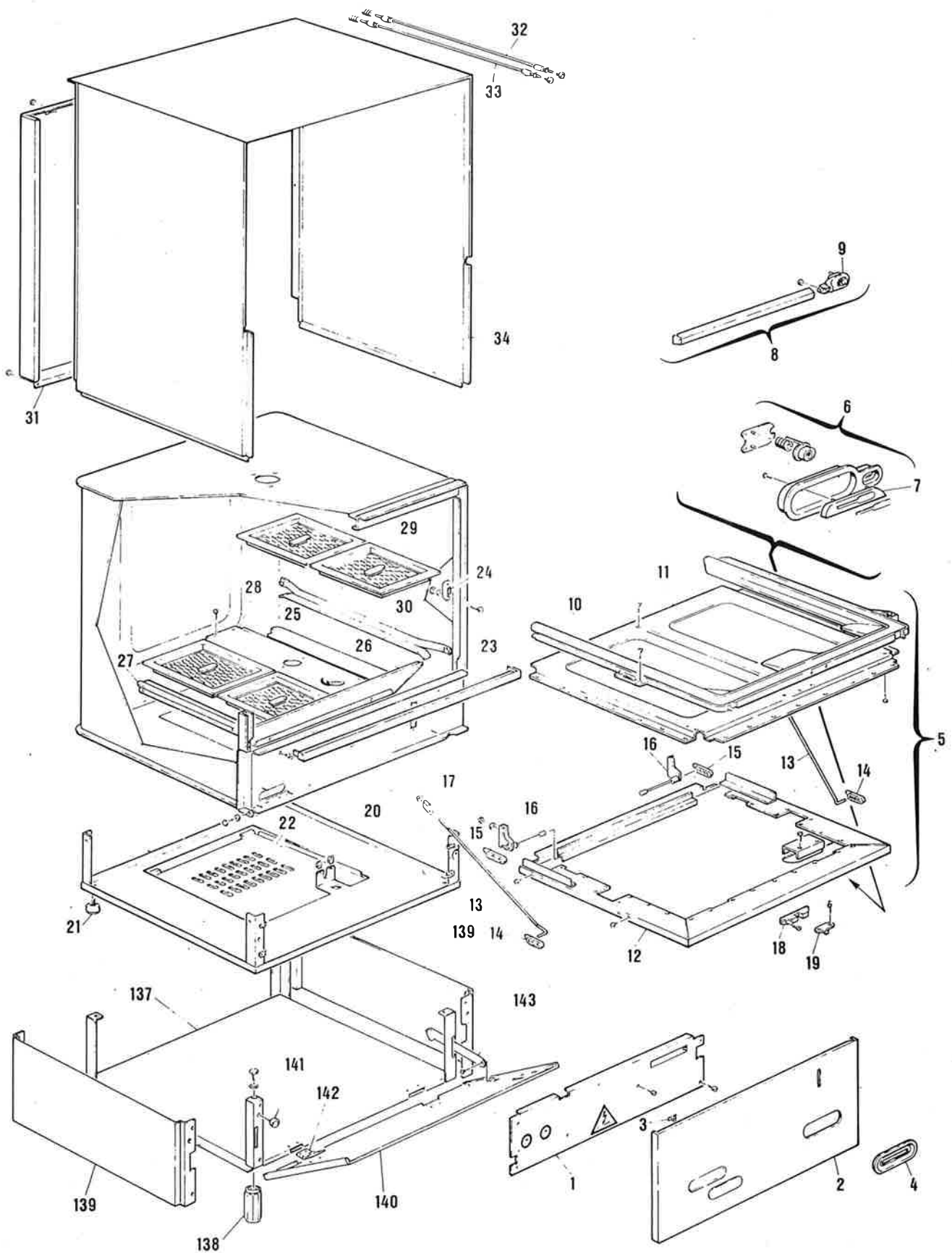

DA MATRICOLA N° 80212 VEDI PAGINA N° 19  
DE MATRICULE NR. 80212 VOIR PAGE NR. 19  
FROM SERIAL NO. 80212 SEE PAGE NO. 19  
AB MASCHINEN NR. 80212 SIEHE SEITE NR. 19



mod. S:  
651 - R651 - 651/P - 653  
654 - 655 - 830 - 835

FINO MATRICOLA N° 80211  
TILL SERIAL NO. 80211  
AU MATRICULE N° 80211  
BIS MASCHINEN-NR. 80211

12

10/87

POS.	CODICE CODE KODE	POS.	CODICE CODE KODE	POS.	CODICE CODE KODE	POS.	CODICE CODE KODE
1	02 40 04	31	02 20 10				
2	01 20 18	32	98 10 05				
3	49 90 07	33	98 10 04				
4	{ 40 40 01 40 40 02	34	01 00 04				
5	02 90 16	137	04 00 03				
6	44 70 37	138	46 10 06				
7	44 70 36	139	02 10 01				
8	44 70 38	140	02 00 01				
9	22 60 10	141	31 00 02				
10	32 80 04	142	49 90 13				
11	33 30 03	143	{ 30 40 05 30 40 07				
13	30 40 08						
14	{ 47 80 19 47 80 20						
15	{ 30 70 01 30 70 02						
16	{ 31 10 01 31 10 02						
17	41 70 41						
18	99 40 08						
19	12 30 11						
20	04 00 05						
21	46 10 09						
22	03 00 03						
23	32 80 05						
24	30 70 03						
25	03 70 03						
26	03 70 02						
27	03 70 04						
28	03 70 01						
29	12 10 23						
30	01 50 03						

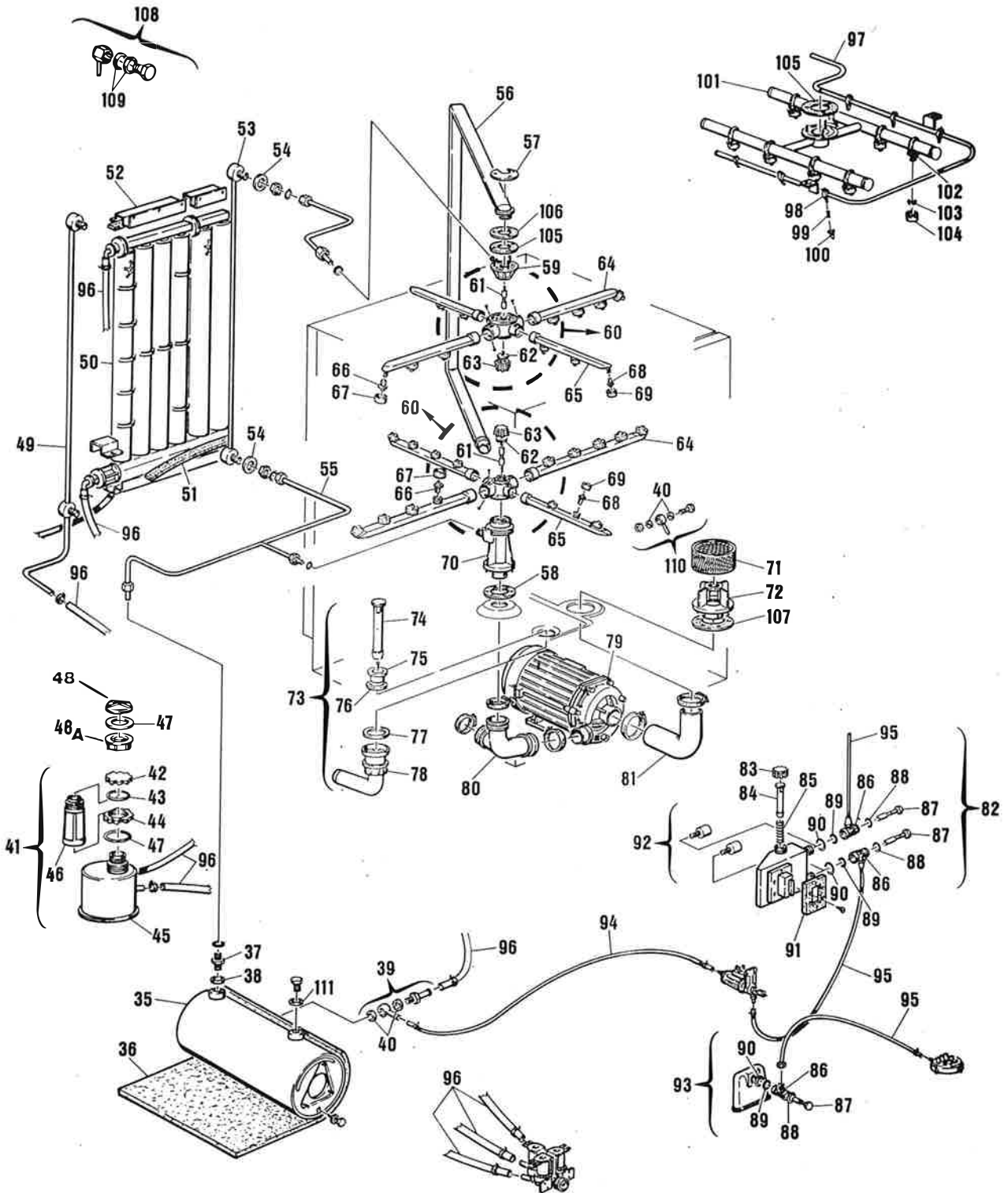

DA MATRICOLA N° 80212 VEDI PAGINA N° 21  
DE MATRICULE NR. 80212 VOIR PAGE NR. 21  
FROM SERIAL NO. 80212 SEE PAGE NO. 21  
AB MASCHINEN NR. 80212 SIEHE SEITE NR. 21

**E3 wolk**

mod. S:

**651 - R651 - 651/P - 653****654 - 655 - 830 - 835**

FINO MATRICOLA N° 80211

TILL SERIAL NO. 80211

AU MATRICULE N° 80211

BIS MASCHINEN-NR. 80211

14

10/87

POS.	CODICE CODE KODE	POS.	CODICE CODE KODE	POS.	CODICE CODE KODE	POS.	CODICE CODE KODE
35	98 20 07	67	42 90 07	100	14 00 06		
36	41 30 01	68	14 00 07	101	99 00 07		
37	46 80 04	69	42 90 06	102	11 00 04		
38	43 70 42	70	11 50 13	103	11 90 02		
39	99 10 01	71	12 10 11	104	14 00 03		
40	43 70 07	72	47 80 15	105	43 70 17		
41	40 69 99	73	99 90 20	106	43 70 18		
42	48 00 05	74	14 20 11	107	43 70 15		
43	45 60 16	75	14 20 01	109	43 70 42		
44	42 90 11	76	43 70 38	111	43 70 05		
46	46 60 01	77	43 70 33				
47	43 70 34	78	99 90 43				
48	48 00 06	79	pag. 58				
48A	42 90 12	80	12 70 02				
49	11 50 09	81	12 70 03				
50	11 70 02	82	{ 99 90 41				
51	43 70 39		{ 99 90 16				
53	11 50 10	83	48 00 04				
54	43 70 42	84	10 90 02				
55	46 80 28	85	44 90 05				
56	11 10 04	86	46 80 53				
57	02 80 01	87	48 60 02				
58	43 70 16	88/89	45 60 02				
59	11 10 05	90	45 60 06				
60	99 00 09	91	43 70 36				
61	32 70 06	92	41 90 01				
62	45 40 02	93	98 40 01				
63	44 70 30	94	14 30 05				
64	{ 10 60 08	95	14 30 13				
	{ 10 60 06	96	14 30 04				
65	{ 10 60 07	97	99 30 04				
	{ 10 60 05	98	11 00 02				
66	14 00 08	99	13 80 01				

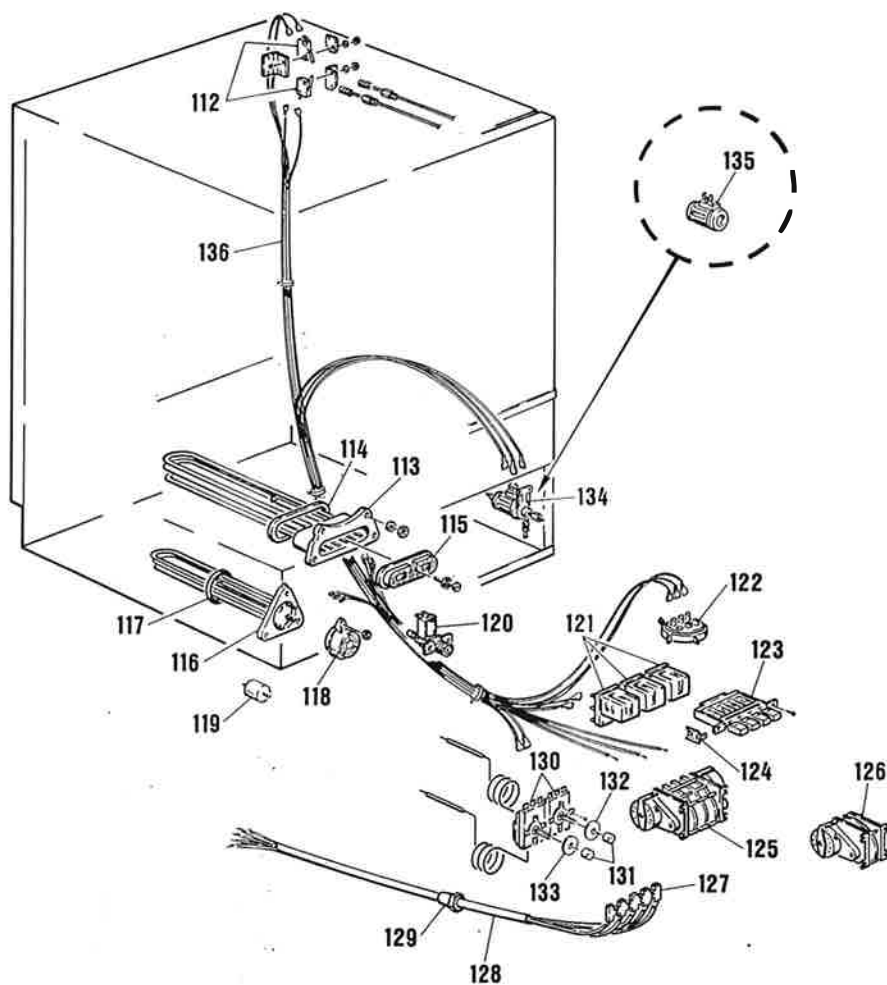

DA MATRICOLA N° 80212 VEDI PAGINA N° 23  
DE MATRICULE NR. 80212 VOIR PAGE NR. 23  
FROM SERIAL NO. 80212 SEE PAGE NO. 23  
AB MASCHINEN NR. 80212 SIEHE SEITE NR. 23

POS.	CODICE CODE KODE	POS.	CODICE CODE KODE	POS.	CODICE CODE KODE	POS.	CODICE CODE KODE
112	21 80 02	136	20 30 21				
113	23 00 43		20 30 22				
	23 00 18		20 30 16				
	23 00 19		20 30 23				
	23 00 28						
114	45 60 08						
115	46 70 01						
116	23 00 13						
	23 00 14						
117	45 60 02						
118	46 70 02						
119	21 20 01						
120	pag. 53						
121	22 90 08						
	22 90 06						
	22 90 10						
	22 90 11						
122	22 40 03						
123	pag. 69						
124	pag. 69						
125	pag. 49						
126	pag. 49						
127	22 00 02						
128	20 40 13						
129	42 50 01						
130	23 60 04						
131	44 70 27						
132	48 11 59						
133	48 11 58						
134	98 70 01						
	98 70 05						
135	20 10 02						
	20 10 11						

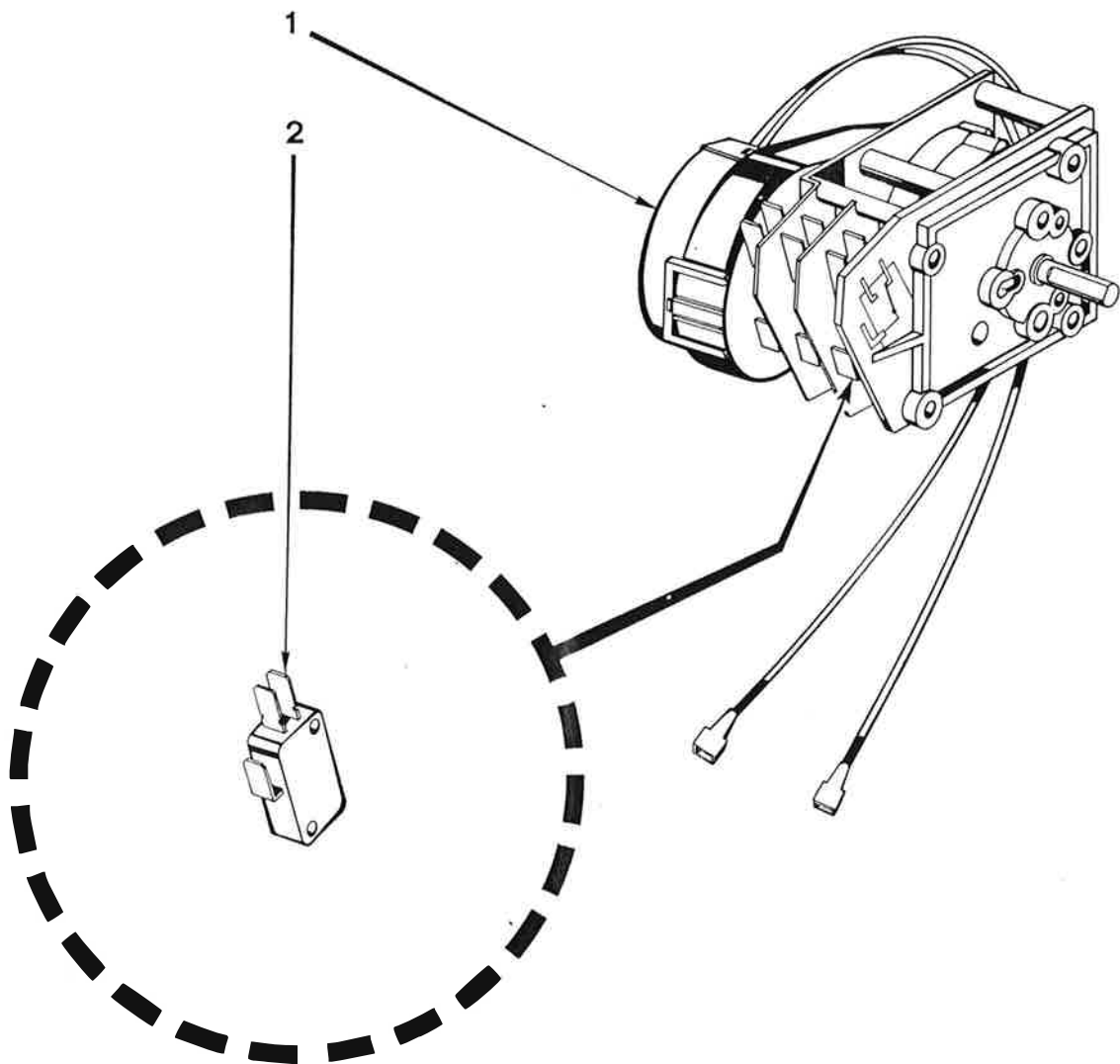



POS.	CODICE CODE KODE	DESCRIZIONE - DESCRIPTION - BESCHREIBUNG
1	23 80 12	Timer ciclo 108" - Cronel 3C Cycle timer 108" - Cronel 3C Programmateur cycle 108" - Cronel 3C Programmschalter 108" - Cronel 3C
1	23 80 26	Timer ciclo 108" - Crouzet 2C Cycle timer 108" - Crouzet 2C Programmateur cycle 108" - Crouzet 2C Programmschalter 108" - Crouzet 2C
1	23 80 07	Timer ciclo 108" - Cronel 3C Cycle timer 108" - Cronel 3C Programmateur cycle 108" - Cronel 3C Programmschalter 108" - Cronel 3C
1	23 80 33	Timer ciclo 150" - Cronel 3C Cycle timer 150" - Cronel 3C Programmateur cycle 150" - Cronel 3C Programmschalter 150" - Cronel 3C
1	23 80 36	Timer ciclo 150" - Crouzet 2C Cycle timer 150" - Crouzet 2C Programmateur cycle 150" - Crouzet 2C Programmschalter 150" - Crouzet 2C
1	23 80 41	Timer ciclo 150" - Cronel 3C Cycle timer 150" - Cronel 3C Programmateur cycle 150" - Cronel 3C Programmschalter 150" - Cronel 3C
1	23 80 03	Timer ciclo 108"/168" - Cronel 4C Cycle timer 108"/168" - Cronel 4C Programmateur cycle 108"/168" - Cronel 4C Programmschalter 108"/168" - Cronel 4C
1	23 80 17	Timer ciclo 108"/168" - Cronel 4C Cycle timer 108"/168" - Cronel 4C Programmateur cycle 108"/168" - Cronel 4C Programmschalter 108"/168" - Cronel 4C

1	23 80 02	Timer ciclo 1' 2' 3' - Cronel 4C Cycle timer 1' 2' 3' - Cronel 4C Programmateur 1' 2' 3' - Cronel 4C Programmschalter 1' 2' 3' - Cronel 4C
1	23 80 22	Timer ciclo 5' 10' - Cronel 4C Cycle timer 5' 10' - Cronel 4C Programmateur 5' 10' - Cronel 4C Programmschalter 5' 10' - Cronel 4C
1	23 80 30	Timer ciclo 3' 6' 9' - Cronel 4C Cycle timer 3' 6' 9' - Cronel 4C Programmateur 3' 6' 9' - Cronel 4C Programmschalter 3' 6' 9' - Cronel 4C
1	23 80 21	Timer ciclo 5' - Cronel 3C Cycle timer 5' - Cronel 3C Programmateur 5' - Cronel 3C Programmschalter 5' - Cronel 3C
1	23 80 11	Timer rigenerazione 15' - Cronel 1C Regeneration timer 15' - Cronel 1C Programmateur regeneration 15' - Cronel 1C Regenerationsschaltwerk 15' - Cronel 1C
1	23 80 06	Timer rigenerazione 15' - Cronel 1C Regeneration timer 15' - Cronel 1C Programmateur regeneration 15' - Cronel 1C Regenerationsschaltwerk 15' - Cronel 1C
1	23 80 27	Timer rigenerazione 15' - Cronel 1C Regeneration timer 15' - Cronel 1C Programmateur regeneration 15' - Cronel 1C Regenerationsschaltwerk 15' - Cronel 1C
1	23 80 10	Timer pompa scarico 108" - Cronel 4C Drain pump timer 108" - Cronel 4C Programmateur pompe vidange 108" - Cronel 4C Laugenpumpe-Programmschalter 108" - Cronel 4C
1	23 80 08	Timer pompa scarico 108" - Cronel 4C Drain pump timer 108" - Cronel 4C Programmateur pompe vidange 108" - Cronel 4C Laugenpumpe-Programmschalter 108" - Cronel 4C
1	23 80 20	Timer pompa scarico 168" - Cronel 4C Drain pump timer 168" - Cronel 4C Programmateur pompe vidange 168" - Cronel 4C Laugenpumpe-Programmschalter 168" - Cronel 4C
1	21 80 09	Micro timer Cronel Microtimer Cronel Minirupteur programmateur Cronel Mikroschalter Cronel

220-240/50/1  
 S 850  
 Mod. S 870  
 da matricola n° 64903  
 from serial no. 64903  
 du matricule n° 64903  
 ab Maschinen-Nr. 64903

220/50/1  
 Mod. S 950  
 fino matricola n° 81059  
 till serial no. 81059  
 au matricule n° 81059  
 bis Maschinen-Nr. 81059

220-240/50/1  
 Mod. S 950  
 da matricola n° 81060  
 from serial no. 81060  
 du matricule n° 81060  
 ab Maschinen-Nr. 81060

220/50/1  
 Versione speciale  
 special version  
 version special  
 besondere Ausführung

220/50/1  
 Mod. S 623 - 626 - 633 -  
 636 - 653

240/50/1  
 Mod. S 623 - 626 - 633 -  
 636 - 653

220/60/1  
 Mod. S 623 - 626 - 633 -  
 636 - 653

220/50/1  
 Mod. S 621 - 624 - 631 -  
 634 - 651 - 654 -  
 655

240/50/1  
 Mod. S 621 - 624 - 631 -  
 634 - 651 - 654 -  
 655

220/50/1  
 Mod. S 621 - 624 - 631 -  
 634 - 651 - 654 -  
 655

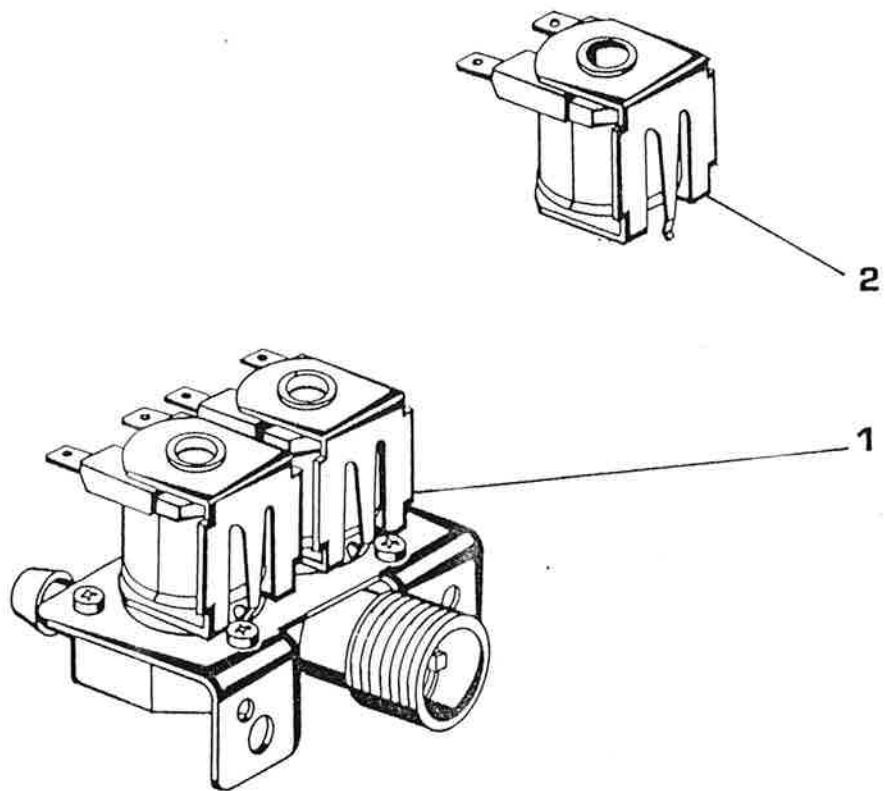

POS.	CODICE CODE KODE	DESCRIZIONE - DESCRIPTION - BESCHREIBUNG
1	24 00 05	<p>Valvola - Elbi - 1 via 180°                      Solenoid valve - Elbi - 1 way 180°                      Vanne - Elbi - 1 bobine 180°                      Einweg - Einlassmagnetventil - Elbi - 180°</p> <p style="text-align: center;">220-240/50-60/1</p> <p>Mod. S 651/P - 655                       Mod. S 830 - 835                      fino matricola n° 80211                      till serial no. 80211                      au matricule n° 80211                      bis Maschinen-Nr. 80211</p>
1	24 00 03	<p>Valvola - 2 vie 180°                      Solenoid valve - 2 ways 180°                      Vanne - 2 bobines 180°                      Zweiweg - Einlassmagnetventil - 180°</p> <p style="text-align: center;">220-240/50-60/1</p> <p>Mod. S 621 - 624 - 631 -                      634 - 651 - 654 -                      810 - 815 - 850 -                      950</p> <p>Mod. S 830 - 835                      da matricola n° 80212                      from serial no. 80212                      du matricule n° 80212                      ab Maschinen-Nr. 80212</p> <p>Mod. S 870                      da matricola n° 64903                      from serial no. 64903                      du matricule n° 64903                      ab Maschinen-Nr. 64903</p>
1	24 00 02	<p>Valvola - 3 vie 180°                      Solenoid valve - 3 ways 180°                      Vanne - 3 bobines 180°                      Dreiweg - Einlassmagnetventil - 180°</p> <p style="text-align: center;">220-240/50-60/1</p> <p>Mod. S 623 - 626 - 633 -                      636 - 653</p>
2	20 10 06	<p>Bobina valvola                      Coil for solenoid valve                      Bobine pour vanne                      Spule für Einlassmagnetventil</p>

POMPA  
WASH PUMP  
POMPE  
ELEKTROPUMPE

mod. S:  
651 - 651/P - R651 - 653  
654 - 655 - 830 - 835

FINO MATRICOLA N° 80211  
TILL SERIAL NO. 80211  
AU MATRICULE N° 80211  
BIS MASCHINEN-NR. 80211

58

10/87

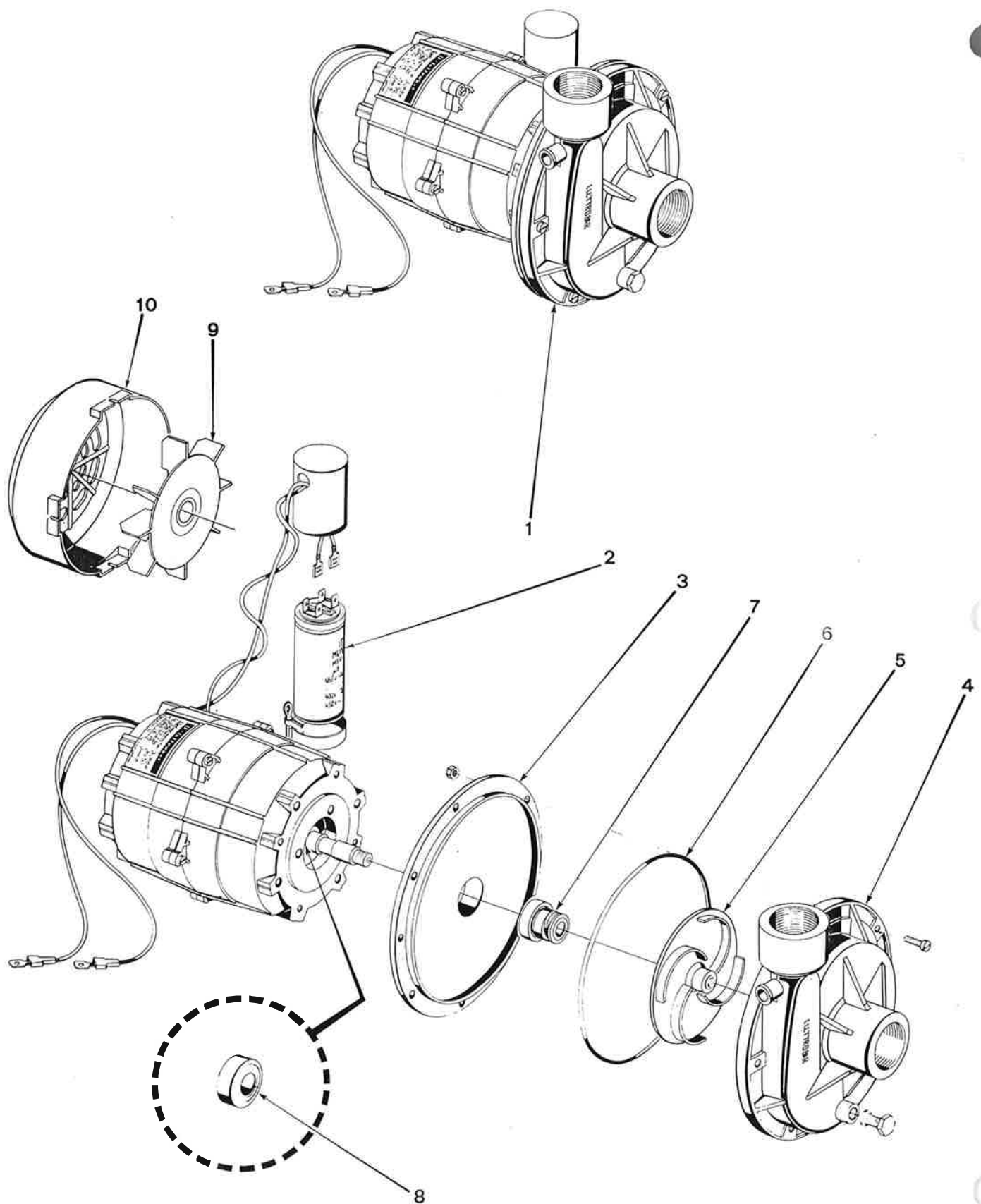

DA MATRICOLA N° 80212 VEDI PAGINA N° 61  
DE MATRICULE N° 80212 VOIR PAGE NR. 61  
FROM SERIAL NO. 80212 SEE PAGE NO. 61  
AB MASCHINEN-NR. 80212 SIEHE SEITE NR. 61



POMPA  
WASH PUMP  
POMPE  
ELEKTROPUMPE

mod. S:

51 - 651/P - R 651 - 653  
654 - 655 - 830 - 835

FINO MATRICOLA N° 80211  
TILL SERIAL NO. 80211  
AU MATRICULE N° 80211  
BIS MASCHINEN-NR. 80211

59

10/87

POS.	CODICE CODE KODE	DESCRIZIONE - DESCRIPTION - BESCHREIBUNG
1	13 00 18	Pompa LCT 150 HP 1,5 Wash pump LCT 150 HP 1,5 Pompe LCT 150 HP 1,5 Elektropumpe LCT 150 HP 1,5 220/50/1 Mod. S 651 - 651/P - R 651 - 653 - 654 - 655 - 830 - 835
1	13 00 20	Pompa LCT 150 HP 1,5 Wash pump LCT 150 HP 1,5 Pompe LCT 150 HP 1,5 Elektropumpe LCT 150 HP 1,5 220-380/50/3 Mod. S 651 - 651/P - R 651 - 653 - 654 - 655 - 830 - 835
1	13 00 17	Pompa LCT 150 HP 1,5 Wash pump LCT 150 HP 1,5 Pompe LCT 150 HP 1,5 Elektropumpe LCT 150 HP 1,5 240/50/1 Mod. S 651 - 651/P - R 651 - 653 - 654 - 655 - 830 - 835
1	13 00 41	Pompa LCT 150 HP 1,5 Wash pump LCT 150 HP 1,5 Pompe LCT 150 HP 1,5 Elektropumpe LCT 150 HP 1,5 220-380/60/3 Mod. S 651 - 651/P - R 651 - 653 - 654 - 655 - 830 - 835
2	20 60 05	Condensatore LCT 150 Condenser LCT 150 Condensateur LCT 150 Kondensator LCT 150
3	31 50 10	Flangia LCT 150 Flange int. LCT 150 Flansque int. LCT 150 Flansch LCT 150
4	11 60 13	Corpo pompa LCT 150 Flange extr. LCT 150 Flansque ext. LCT 150 Pumpengehäuse LCT 150
5	12 40 11	Girante LCT 150 50 Hz. Impellor LCT 150 50 Hz. Turbine LCT 150 50 Hz. Pumpenflügel LCT 150 50 Hz.

**E3 wolk**

POMPA  
WASH PUMP  
POMPE  
ELEKTROPUMPE

mod. S:

651 - 651/P - R 651 - 653  
654 - 655 - 830 - 835

FINO MATRICOLA N° 80211  
TILL SERIAL NO. 80211  
AU MATRICULE N° 80211  
BIS MASCHINEN-NR. 80211

60

10/87

POS.	CODICE CODE KODE	DESCRIZIONE - DESCRIPTION - BESCHREIBUNG
5	12 40 18	Girante LCT 150 60 Hz. Impellor LCT 150 60 Hz. Turbine LCT 150 60 Hz. Pumpenflügel LCT 150 60 Hz.
6	45 60 22	OR LCT 150 O-ring LCT 150 Joint thorique LCT 150 O-Ring Dichtung LCT 150
7	14 10 03	Tenuta meccanica LCT 150 Seal LCT 150 Presse etoupe LCT 150 Gleitringdichtung LCT 150
8	31 40 02	Cuscinetto LCT 150 Bearing LCT 150 Roulement LCT 150 Kugellager LCT 150
9	33 50 04	Ventola LCT 150 Fan LCT 150 Turbine de refroidissement LCT 150 Flügel LCT 150
10	31 30 05	Copriventola LCT 150 Fan protection LCT 150 Protection turbine LCT 150 Flügelschutz LCT 150

**E3 wolk**

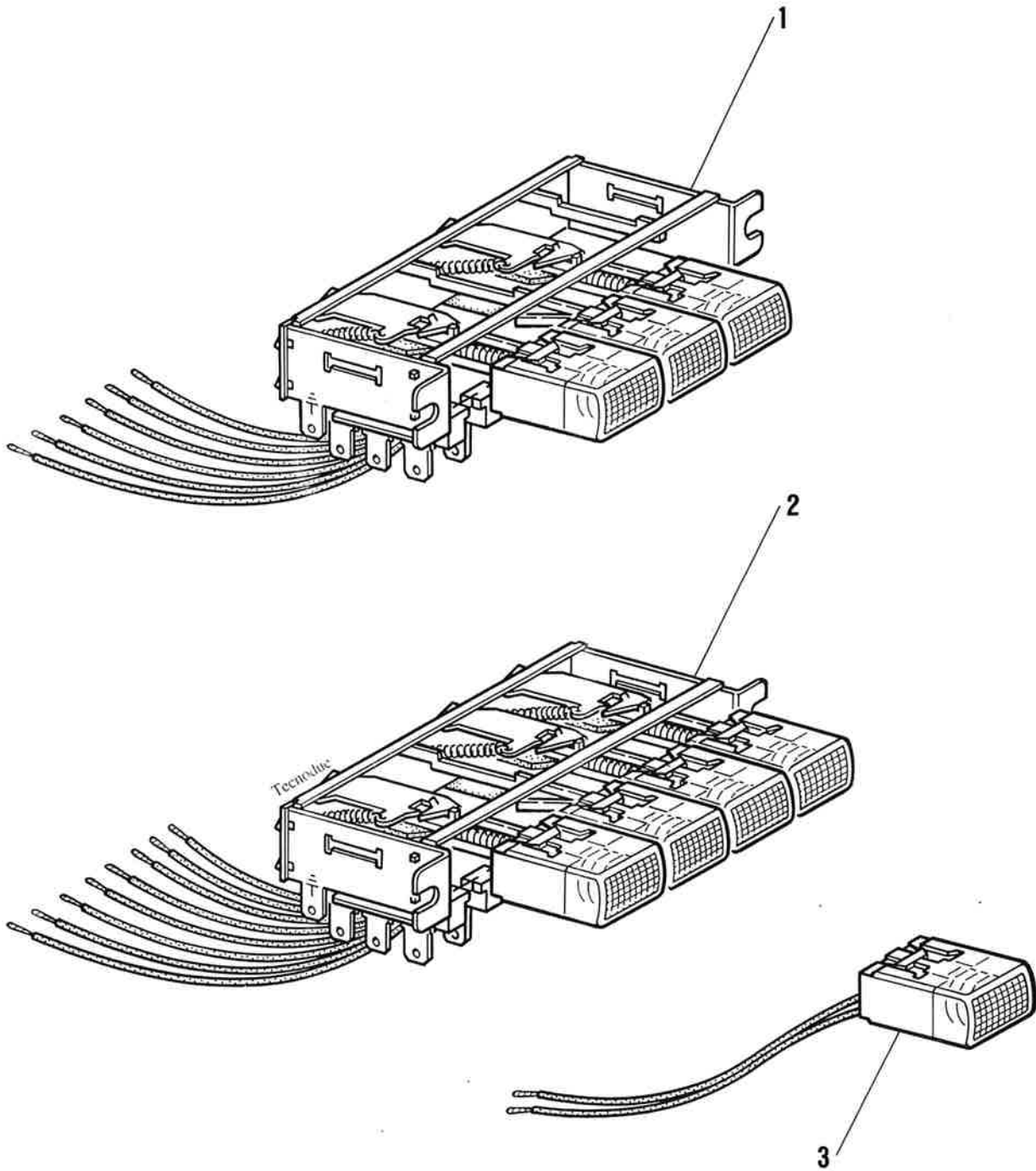

POS.	CODICE CODE KODE	DESCRIZIONE - DESCRIPTION - BESCHREIBUNG
1	22 70 02	<p>Pulsantiera 3 pulsanti Keyboard 3 push buttons Clavier 3 boutons Bedienungsschalter 3 Schalter</p> <p>Mod. S 621 - 624 - 631 - 634 - 651 - 654 - 810 - 835</p> <p>Mod. S 830 da matricola n° 80212 from serial no. 80212 du matricule n° 80212 ab Maschinen-Nr. 80212</p> <p>Mod. S 950 fino matricola n° 81059 till serial no. 81059 au matricule n° 81059 bis Maschinen-Nr. 81059</p>
2	22 70 03	<p>Pulsantiera 4 pulsanti Keyboard 4 push buttons Clavier 4 boutons Bedienungsschalter 4 Schalter</p> <p>Mod. S 623 - 626 - 633 - 636 - 651/P - 653 - 655</p> <p>Mod. S 830 fino matricola n° 80211 till serial no. 80211 au matricule n° 80211 bis Maschinen-Nr. 80211</p> <p>Mod. S 850 fino matricola n° 81936 till serial no. 81936 au matricule n° 81936 bis Maschinen-Nr. 81936</p>
2	22 70 03	<p>Pulsantiera 4 pulsanti - Pompa scarico Keyboard 4 push buttons - Drain pump Clavier 4 boutons - Pompe vidange Bedienungsschalter 4 Schalter - Laugenpumpe</p> <p>Mod. S 621 - 624 - 631 - 634 - 651 - 654 - 810 - 835</p>
2	22 70 01	<p>Pulsantiera 4 pulsanti Keyboard 4 push buttons Clavier 4 boutons Bedienungsschalter 4 Schalter</p> <p>Mod. S 850 da matricola n° 81937 till serial no. 81937 du matricule n° 81937 ab Maschinen-Nr. 81937</p>
2	22 70 01	<p>Mod. S 950 da matricola n° 81060 from serial no. 81060 du matricule n° 81060 ab Maschinen-Nr. 81060</p> <p>Mod. S 870 da matricola n° 64903 from serial no. 64903 du matricule n° 64903 ab Maschinen-Nr. 64903</p>

POS.	CODICE CODE KODE	DESCRIZIONE - DESCRIPTION - BESCHREIBUNG
3	22 60 05	<p>Pulsante arancione Orange push button Bouton orange Orange Schalter</p>
3	22 60 06	<p>Pulsante bianco White push button Bouton blanc Weisse Schalter</p>
3	22 60 07	<p>Pulsante verde Green push button Bouton vert Grüne Schalter</p>
3	22 60 08	<p>Pulsante giallo Yellow push button Bouton jaune Gelbe Schalter</p>

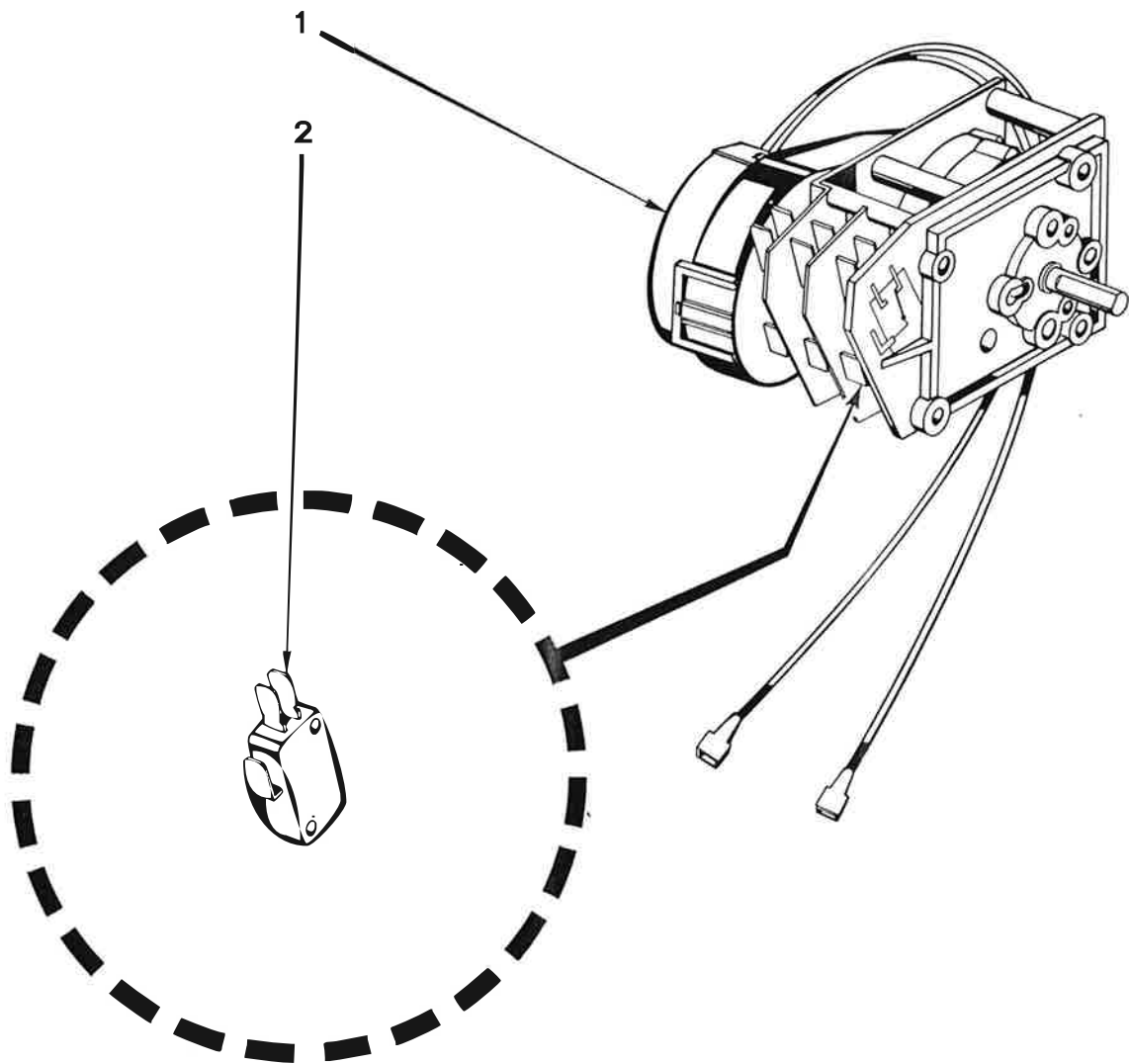



POS.	CODICE CODE KODE	DESCRIZIONE - DESCRIPTION - BESCHREIBUNG
1	23 80 25	Timer ciclo 180" - Cronel 2C Cycle timer 180" - Cronel 2C Programmateur cycle 180" - Cronel 2C Programmschalter 180" - Cronel 2C 220/50/1 Mod. R 495 - 497
1	23 80 01	Timer ciclo 180" - Crouzet 3C Cycle timer 180" - Crouzet 3C Programmateur cycle 180" - Crouzet 3C Programmschalter 180" - Crouzet 3C 220/50/1 Mod. R 499 - 501 - 503 - 505 - 507 - 509 - 511 - 704 - 706 - 708 - S 641 - 643  Mod. S 870 fino matricola n° 64902 till serial no. 64902 au matricule n° 64902 bis Maschinen-Nr. 64902
1	23 80 24	Timer ciclo 180" - Cronel 3C Cycle timer 180" - Cronel 3C Programmateur cycle 180" - Cronel 3C Programmschalter 180" - Cronel 3C 220/50/1 Mod. R 499 - 501 - 503 - 505 - 507 - 509 - 511 - 704 - 706 - 708 - S 641 - 643  Mod. S 870 fino matricola n° 64902 till serial no. 64902 au matricule n° 64902 bis Maschinen-Nr. 64902
1	23 80 05	Timer ciclo 180" - Cronel 3C Cycle timer 180" - Cronel 3C Programmateur cycle 180" - Cronel 3C Programmschalter 180" - Cronel 3C 220-240/50/1 Mod. R 499 - 501 - 503 - 505 - 507 - 509 - 511 - 704 - 706 - 708 - S 641 - 643  Mod. S 870 fino matricola n° 64902 till serial no. 64902 au matricule n° 64902 bis Maschinen-Nr. 64902
1	23 80 16	Timer ciclo 180" - Cronel 3C Cycle timer 180" - Cronel 3C Programmateur cycle 180" - Cronel 3C Programmschalter 180" - Cronel 3C 220/60/1 Mod. R 499 - 501 - 503 - 505 - 507 - 509 - 511 - 704 - 706 - 708 - S 641 - 643  Mod. S 870 fino matricola n° 64902 till serial no. 64902 au matricule n° 64902 bis Maschinen-Nr. 64902

POS.	CODICE CODE KODE	DESCRIZIONE - DESCRIPTION - BESCHREIBUNG
1	23 80 09	Timer pompa scarico 180" - Cronel 4C Drain pump timer 180" - Cronel 4 Programmateur pompe vidange 180" - Cronel 4C Laugenpumpe-Programmschalter 180" - Cronel 4C 220/50/1 Mod. R 501 - 505 - 509 - 704 - 706 - 708 - S 641  Mod. S 870 fino matricola n° 64902 till serial no. 64902 au matricule n° 64902 bis Maschinen-Nr. 64902
2	21 80 09	Micro timer Cronel Microtimer Cronel Minirupteur programmateur Cronel Mikroschalter Cronel

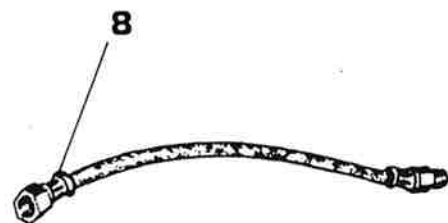
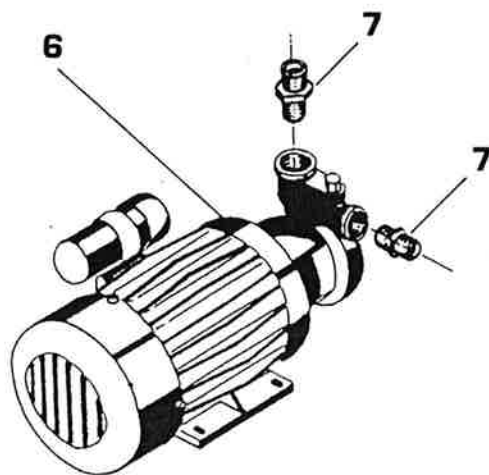
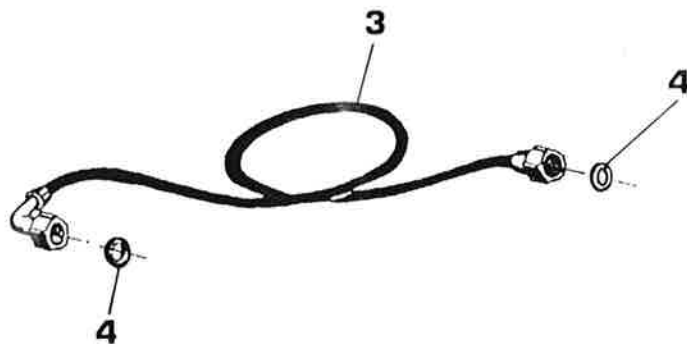
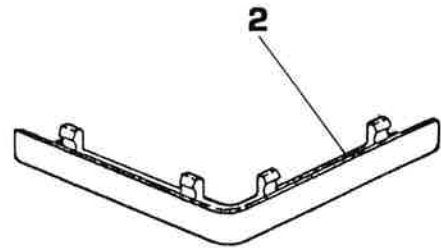
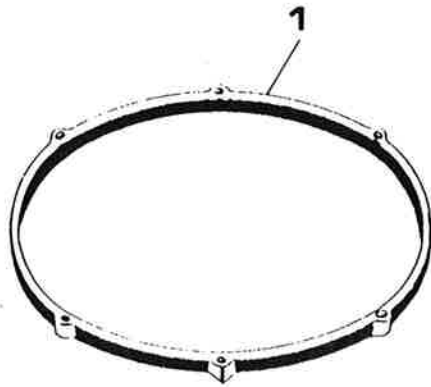

**E3 wolk**

ACCESSORI LAVASTOVIGLIE  
 DISHWASHERS' ACCESSORIES  
 ACCESSOIRES LAVE VAISSELLE  
 GESCHIRRSPÜLMASCHINEN-ZUBEHÖR

113

10/87

**E3 wolk**

ACCESSORI LAVASTOVIGLIE  
 DISHWASHERS' ACCESSORIES  
 ACCESSOIRES LAVE VAISSELLE  
 GESCHIRRSPÜLMASCHINEN-ZUBEHÖR

114

10/87

POS.	CODICE CODE KODE	DESCRIZIONE - DESCRIPTION - BESCHREIBUNG	POS.	CODICE CODE KODE	DESCRIZIONE - DESCRIPTION - BESCHREIBUNG
1	70 20 02	Anello cesto ø 33 Rack ring ø 33 Volant panier ø 33 Körbring ø 33 Mod. R 495	5	14 30 19 *	Tubo scarico ø 25 Drain pipe ø 25 Tuyau vidange ø 25 Ablaufschlauch ø 25 Mod. S 621 - 623 - 624 - 626 - 631 - 633 - 634 - 636 - 641 - 643 Mod. R 495 - 497 - 499 - 501 - 503 - 505 - 507 - 509 - 511
1	70 20 01	Anello cesto ø 38 Rack ring ø 38 Volant panier ø 38 Körbring ø 38 Mod. S 624 - 626 - 634 - 636 - R 651 - 654 - 655 - 815 - 835 Mod. R 497 - 499 - 501 - 503 - 505 - 507 - 509 - 511 - 704 - 706 - 708	5	14 30 20 *	Tubo scarico ø 38 Drain pipe ø 38 Tuyau vidange ø 38 Ablaufschlauch ø 38 Mod. S 651 - R 651 - 651/P - 653 - 654 - 655 - 810 - 815 - 830 - 835 - 850 - 870 - 950 Mod. R 704 - 706 - 708
2	46 10 03	Piedino cesto grigio Grey rack feet Pied panier gris Grauer Korbfuss Mod. S 621 - 623 - 631 - 633 - 641 - 643 - 651 - 651/P - 653 - 810 - 830 - 850 - 870	6	pag. 115	Pompa ausiliaria Rinse booster pump Pompe de rinçage Nachspülpumpe
3	14 30 16 *	Tubo carico con curva 3/4 gas Inlet pipe with bend 3/4 gas Tuyau alimentation avec courbe 3/4 gaz Zulaufschlauch mit Kurve 3/4 Gas Mod. S 621 - 623 - 624 - 626 - 631 - 633 - 634 - 636 - 641 - 643 - 651 - R 651 - 651/P - 653 - 654 - 655 - 810 - 815 - 830 - 835 Mod. R 495 - 497 - 499 - 501 - 503 - 505 - 507 - 509 - 511 - 704 - 706 - 708 -	7	46 80 26	Raccordo pompa ausiliaria Rinse booster pump connection Raccord pompe rinçage Nachspülpumpe-Anschluss
3	14 30 18 *	Tubo carico 19 x 26 Inlet pipe 19 x 26 Tuyau alimentation 19 x 26 Zulaufschlauch 19 x 26 Mod. S 850 - 870 - 950	8	14 30 21	Tubo flessibile pompa ausiliaria Rinse booster pump's flexible pipe Tuyau flexible pompe rinçage Nachspülpumpe-Schlauch
4	43 70 41	Guarnizione carico 3/4 gas Inlet gasket 3/4 gas Joint alimentation 3/4 gaz Zulaufdichtung 3/4 Gas			
5	14 30 17	Tubo scarico Mt. 1,5 ø 22 Drain pipe mt. 1,5 ø 22 Tuyau vidange mt. 1,5 ø 22 Ablaufschlauch Mt. 1,5 ø 22 Modelli con pompa scarico Models with drain pump Modèles avec tuyau vidange Modelle mit Laugenpumpe			

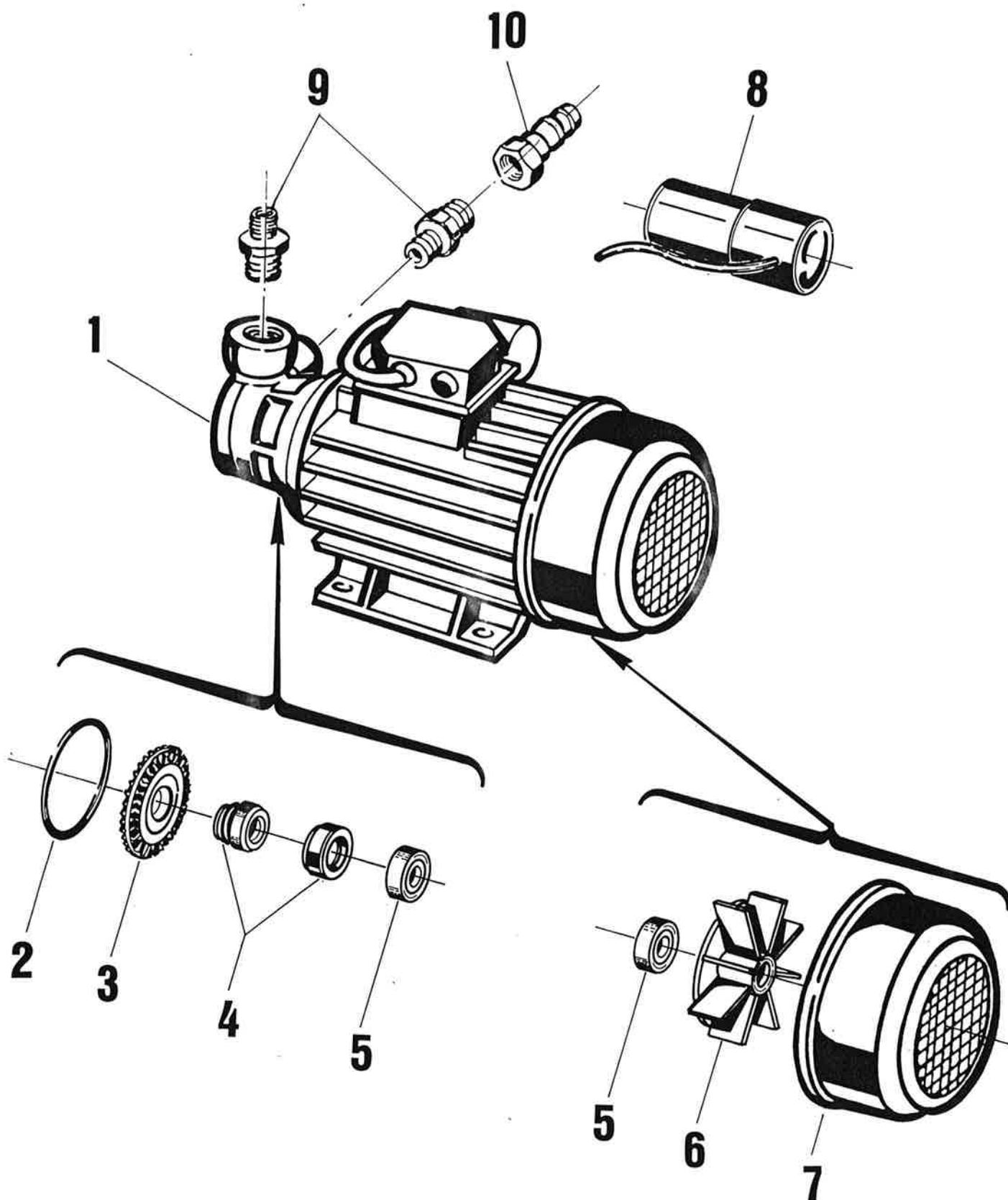

POS.	CODICE CODE KODE	DESCRIZIONE - DESCRIPTION - BESCHREIBUNG	
1	13 00 13	Pompa ausiliaria Dab K 30 HP 0,4 Rinse booster pump Dab K 30 HP 0,4 Pompe rincage Dab K 30 HP 0,4 Nachspülpumpe Dab K 30 HP 0,4	220/50/1  Per tutti i modelli For all the models Tous modeles Für alle Modelle
1	13 00 52	Pompa ausiliaria Dab K 30 HP 0,4 Rinse booster pump Dab K 30 HP 0,4 Pompe rincage Dab K 30 HP 0,4 Nachspülpumpe Dab K 30 HP 0,4	240/50/1  Per tutti i modelli For all the models Tous modeles Für alle Modelle
2	45 60 37	OR K 30 O-ring K 30 Joint thorique K 30 O-Ring Dichtung K 30	
3	12 40 15	Girante K 30 Impellor K 30 Turbine K 30 Pumpenflügel K 30	
4	14 10 02	Tenuta meccanica K 30 Seal K 30 Presse etoupe K 30 Gleitringdichtung K 30	
5	31 40 01	Cuscinetto K 30 Bearing K 30 Roulement K 30 Kugellager K 30	
6	33 50 07	Ventola K 30 Fan K 30 Turbine de refroidissement K 30 Flügel K 30	
7	31 30 08	Copriventola K 30 Fan protection K 30 Protection turbine K 30 Flügelschutz K 30	
8	20 60 01	Condensatore K 30 Condenser K 30 Condensateur K 30 Kondensator K 30	
9	46 80 26	Raccordo K 30 Connection K 30 Raccord K 30 Anschluss K 30	
10	45 30 02	Raccordo pompa ausiliaria Dab K 30 Rinse booster pump connection Dab K 30 Raccord pompe rincage Dab K 30 Nachspülpumpeanschluss Dab K 30	Mod. S 850 - 870 - 950

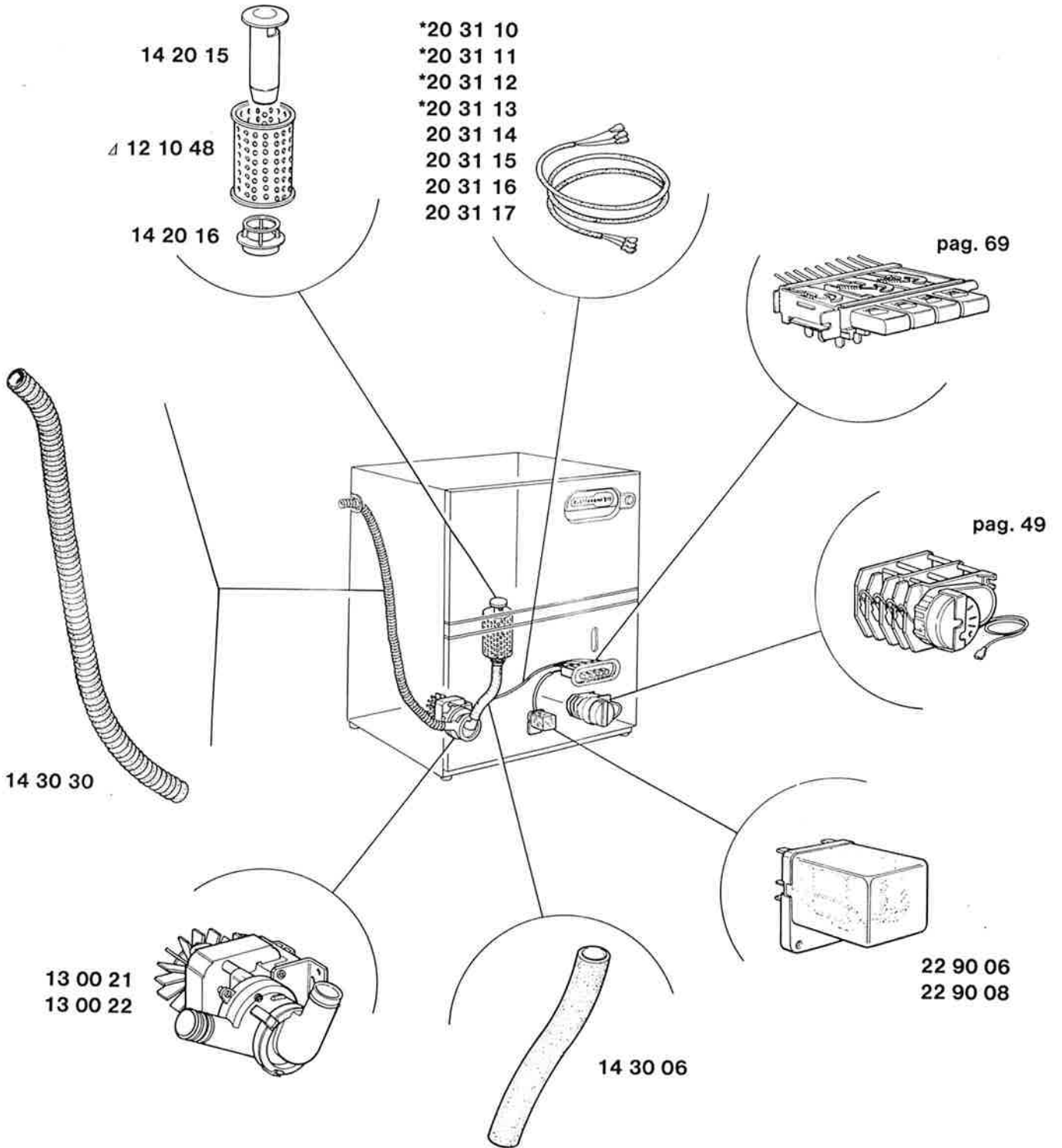

\* DA MATRICOLA N° 80212  
FROM SERIAL NO. 80212  
DU MATRICULE NR. 80212  
AB MASCHINEN NR. 80212

Δ DA MATRICOLA N° 94408  
FROM SERIAL NO. 94408  
DU MATRICULE NR. 94408  
AB MASCHINEN NR. 94408

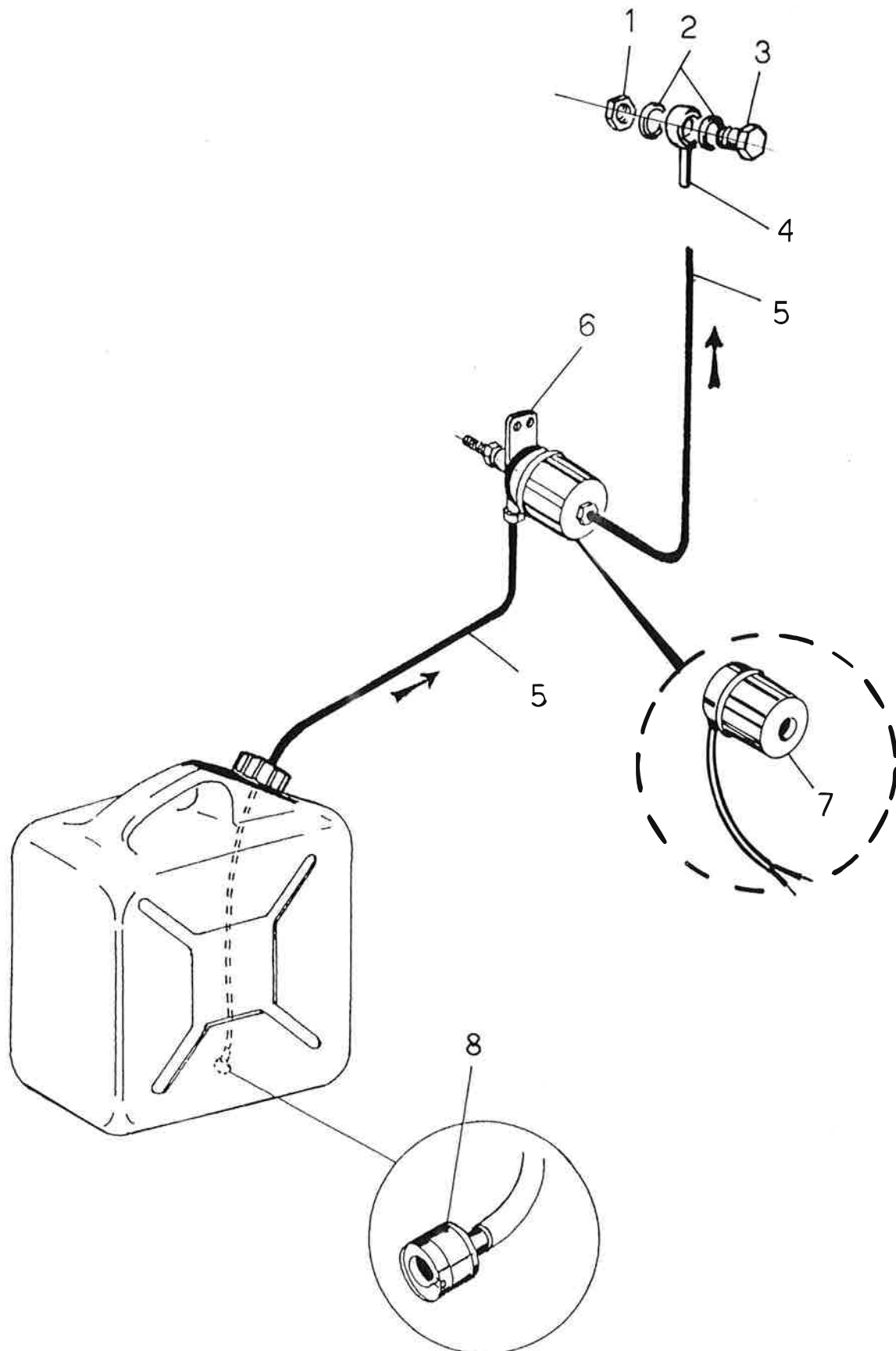



DOSATORE SAPONE  
LIQUID DETERGENT DISPENSER  
DOSEUR DU PRODUIT DE LAVAGE  
SPUELMITTEL-DOSIERGERAET

121

10/87

POS.	CODICE CODE KODE	POS.	CODICE CODE KODE	POS.	CODICE CODE KODE	POS.	CODICE CODE KODE
1	41 70 16						
2	43 70 07						
3	46 80 24						
4	46 80 23						
5	14 30 14						
6	98 70 12						
7	20 10 18						
8	98 60 02						



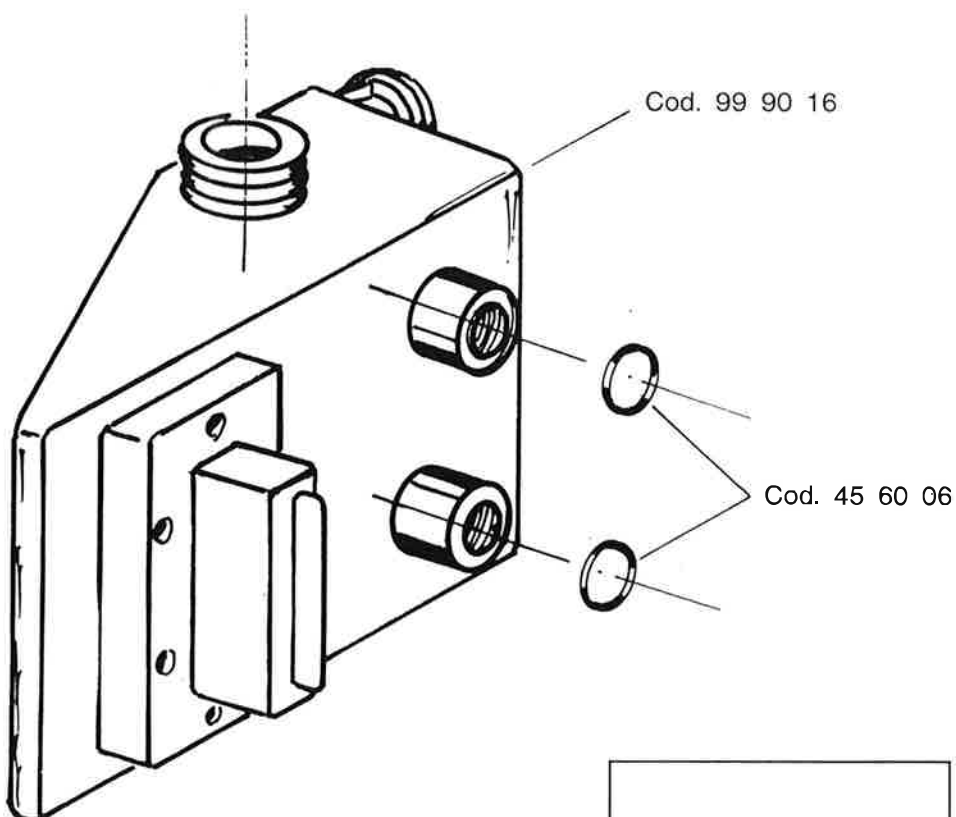
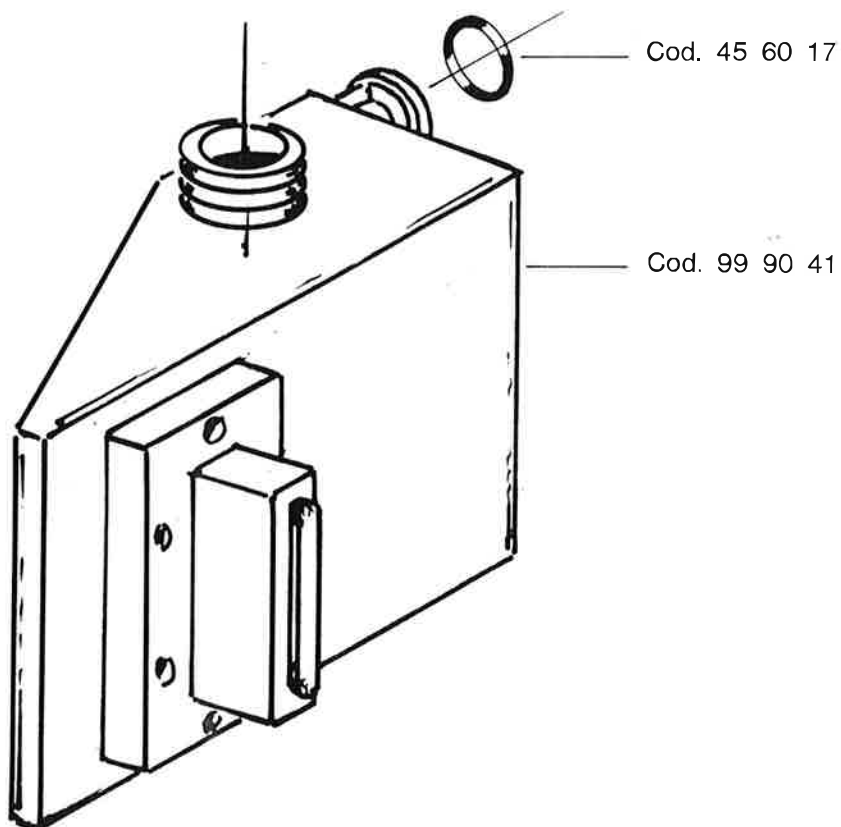

NUOVO  
NEW  
NOUVEAU  
NEU

DA MATRICOLA N° 68473  
DE MATRICULE NR. 68473  
FROM SERIAL NO. 68473  
AB MASCHINEN NR. 68473

**E3 wolk**

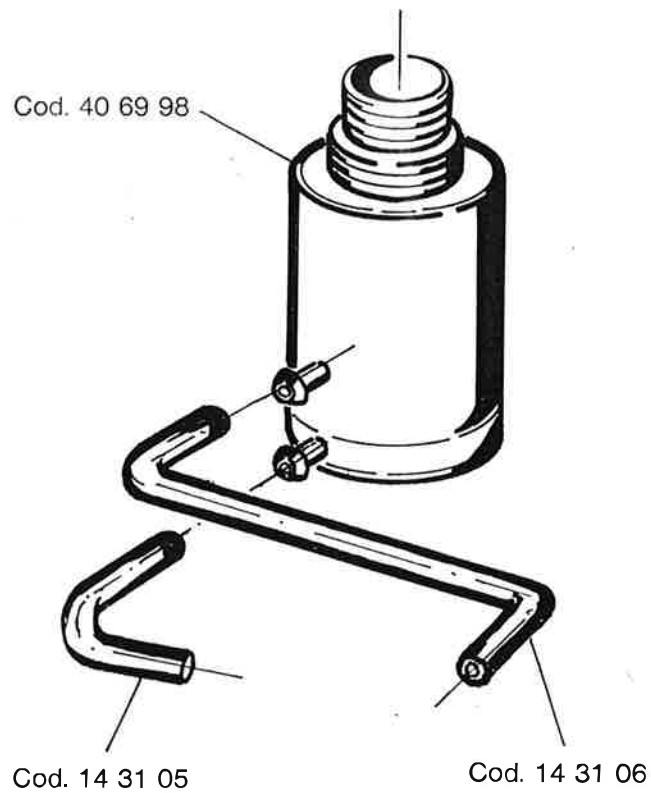
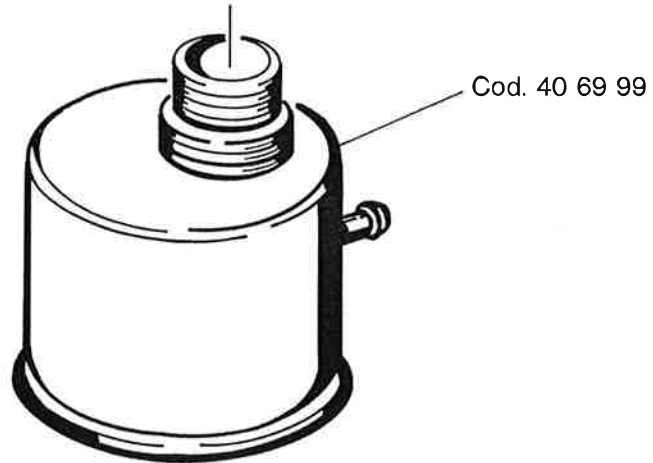

**NUOVO  
NEW  
NEU  
NOUVEAU**

DA MATRICOLA N° 92582  
FROM SERIAL NO. 92582  
AB MASCHINEN NR. 92582  
DU MATRICULE NO. 92582