



IF 55

LIST OF THE EXPLODED VIEWS



SHELL ASSY

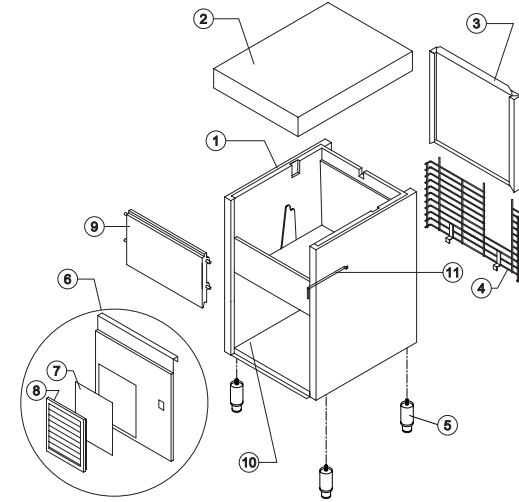

COOLING SYSTEM

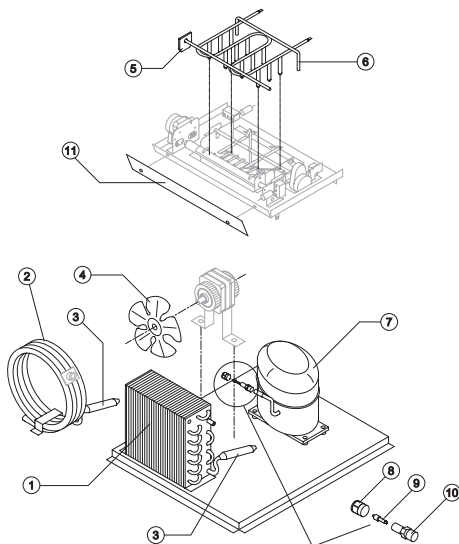

HYDRAULIC CIRCUIT

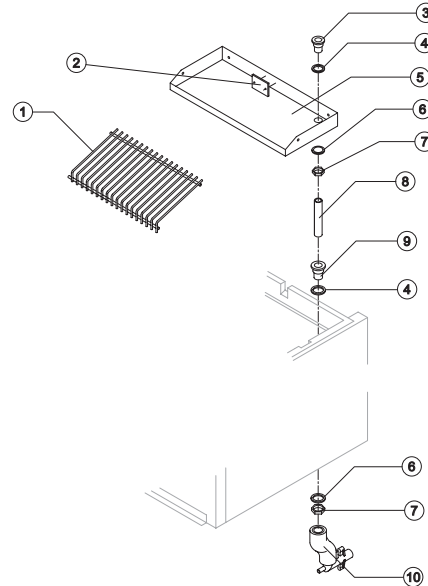

EVAPORATOR SUPPORT

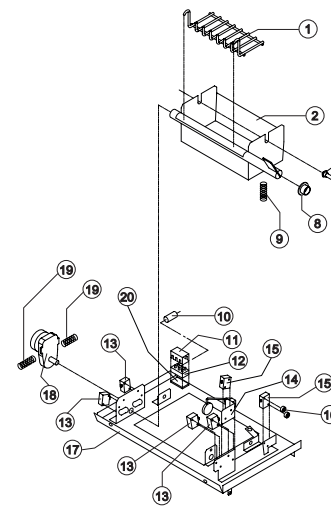

ELECTRIC PARTS

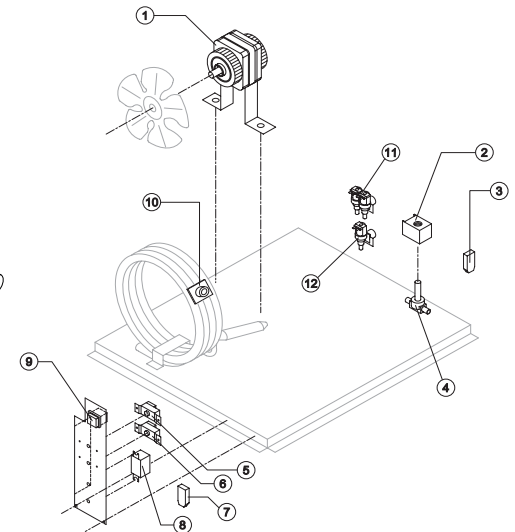

Rev. 1 - 12/6/2002



IF 55

SHELL ASSY

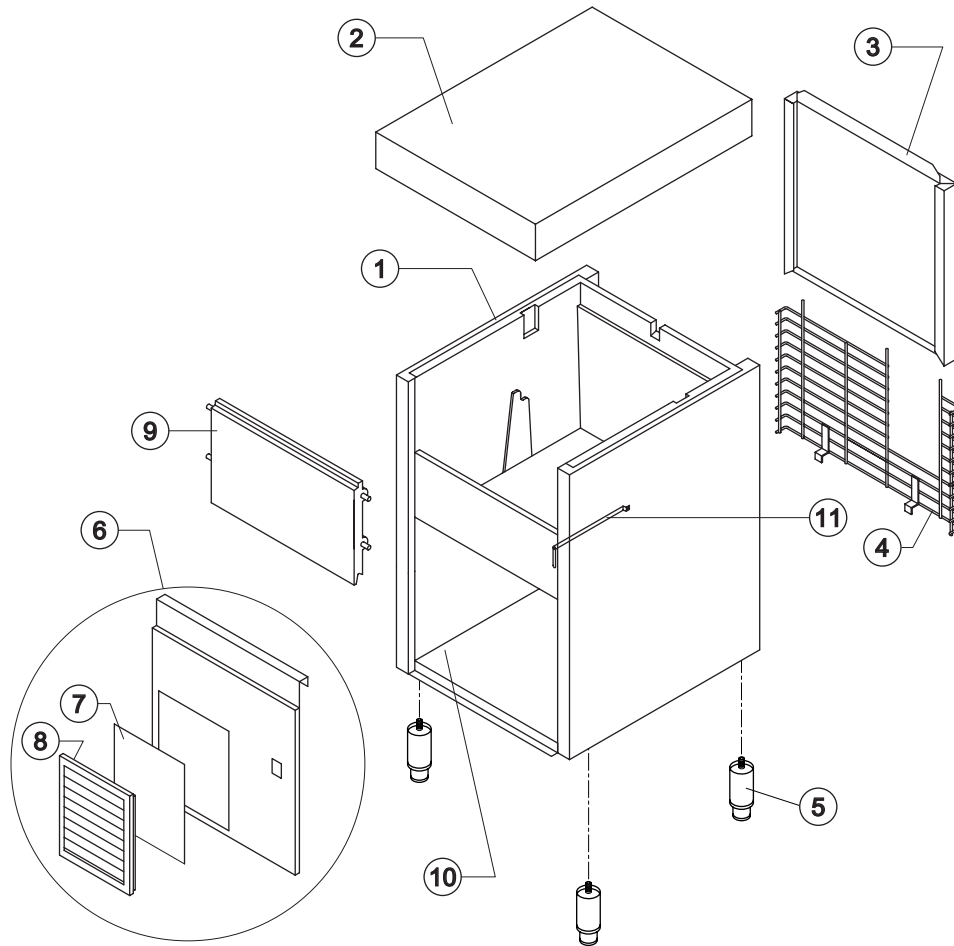

Ref.	Spare Description	Code
1	Foamed Cabinet Assy	C11039/E
2	Top Assembly	C22262
3	Back Panel Assembly	C26419
4	Rear Grid	D12006
5	Stainless Steel Foot Adjustable	Current Version 20613
5	ABS Foot	Till s/n. 141256 10040
6	Front Grid Panel	Current Version C22508
6	Front Panel	Till s/n. 31236 22069
7	Filtering Panel	18106
8	Grid with Frame	C10205
9	Door Assy	C10297
10	Base Plate	Current Version 21279
10	Base Plate	Till s/n. 141256 21013
11	Bulbe Thermostat Tube	Current Version 20522
11	Bulbe Thermostat Tube	Till s/n. 94917 20017

Rev. 1 - 12/6/2002



IF 55

COOLING SYSTEM

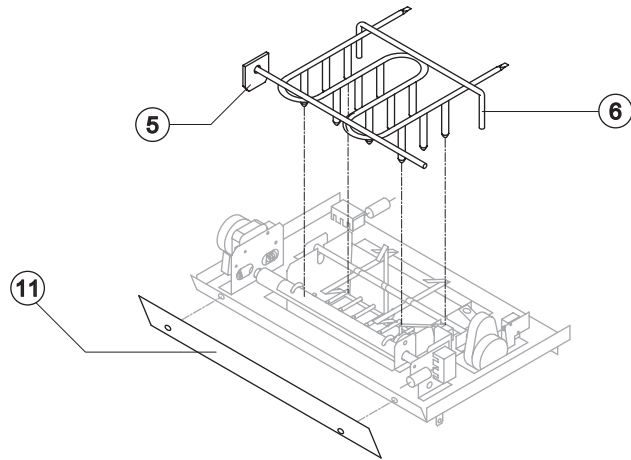

Common Parts

Ref.	Spare Description	Code
3	Molecular Drier	14009
5	Upright	22253
6	Evaporator	D14206
7	Compressor	See Table
8	Vacuum-Charge Valve Plug	14006
9	Vacuum-Charge Valve Device	14005
10	Vacuum-Charge Valve Body	14007
11	Protection Plate	22264

Parts for Air-Cooled Version Only

Ref.	Spare Description	Code
1	Air Condenser	20019
4	Suction Impeller	See Table

Parts for Water-Cooled Version Only

Ref.	Spare Description	Code
2	Water Condenser	14014
4	Suction Impeller	10213

Ref. 7 - Compressor

Tension	Refr. R404A	Refr. R22
220/240V 50 Hz	23441	23313
220/230V 60 Hz	23585	-

Ref. 4 - Suction Impeller

Tension	Code
220/240V 50 Hz	20096
220/230V 60 Hz	20095

Rev. 1 - 12/6/2002

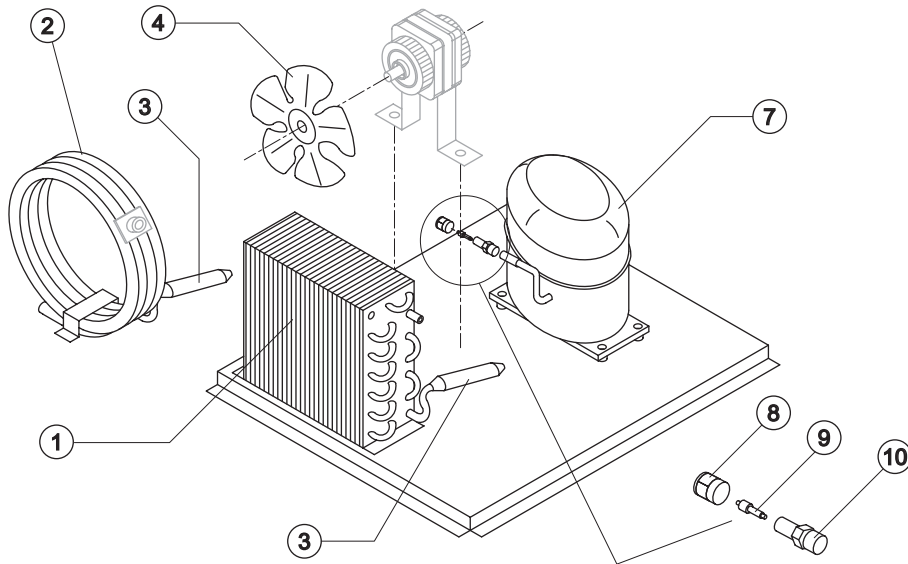



IF 55

HYDRAULIC CIRCUIT

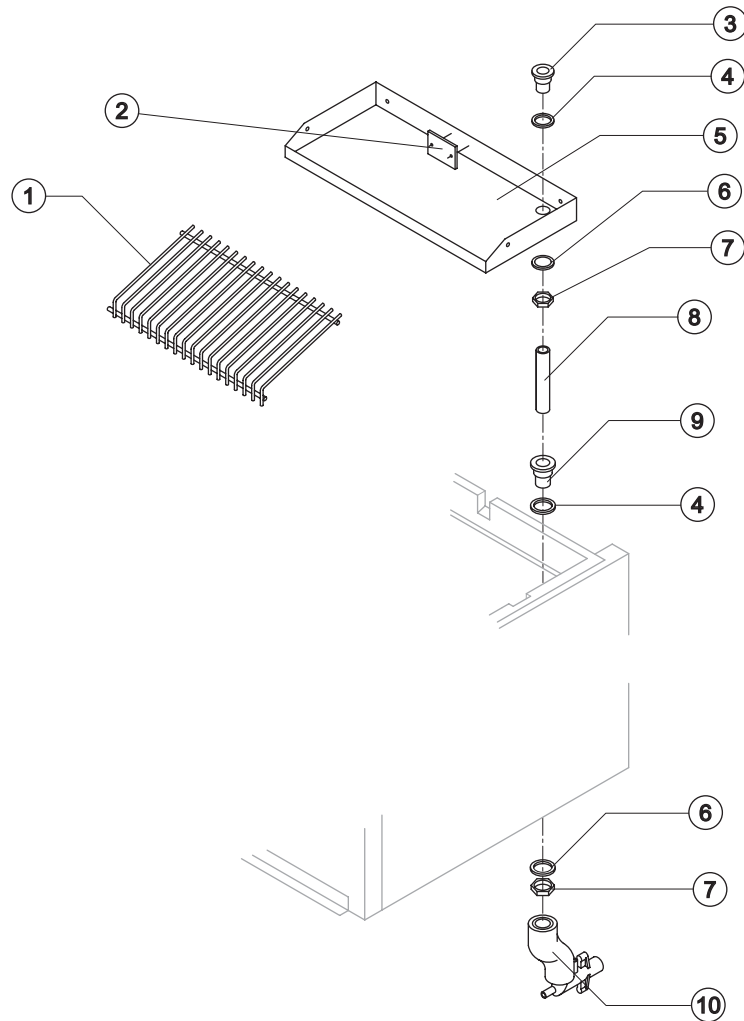

Common Parts

Ref.	Spare Description	Code
1	Ice Cubes Slide	D12042
2	Slide Keep Plate	10009
3	Overflow Pipe Nipple	10241
4	Silicone Gasket	13006
5	Water Basin	22353
6	Semirigid Polyethylene Gasket	13007
7	Bin Discharge Nut	10096
8	Overflow Pipe	Current Version 13108
8	Overflow Pipe	Till s/n. 62623 13057
9	Plastic Nipple Water Outlet	10007

Parts for Air-Cooled Version Only

Ref.	Spare Description	Code
10	Discharges Manifold	C10006

Parts for Water-Cooled Version Only

Ref.	Spare Description	Code
10	Discharges Manifold	C26452

Rev. 1 - 12/6/2002



IF 55

EVAPORATOR SUPPORT PLATE

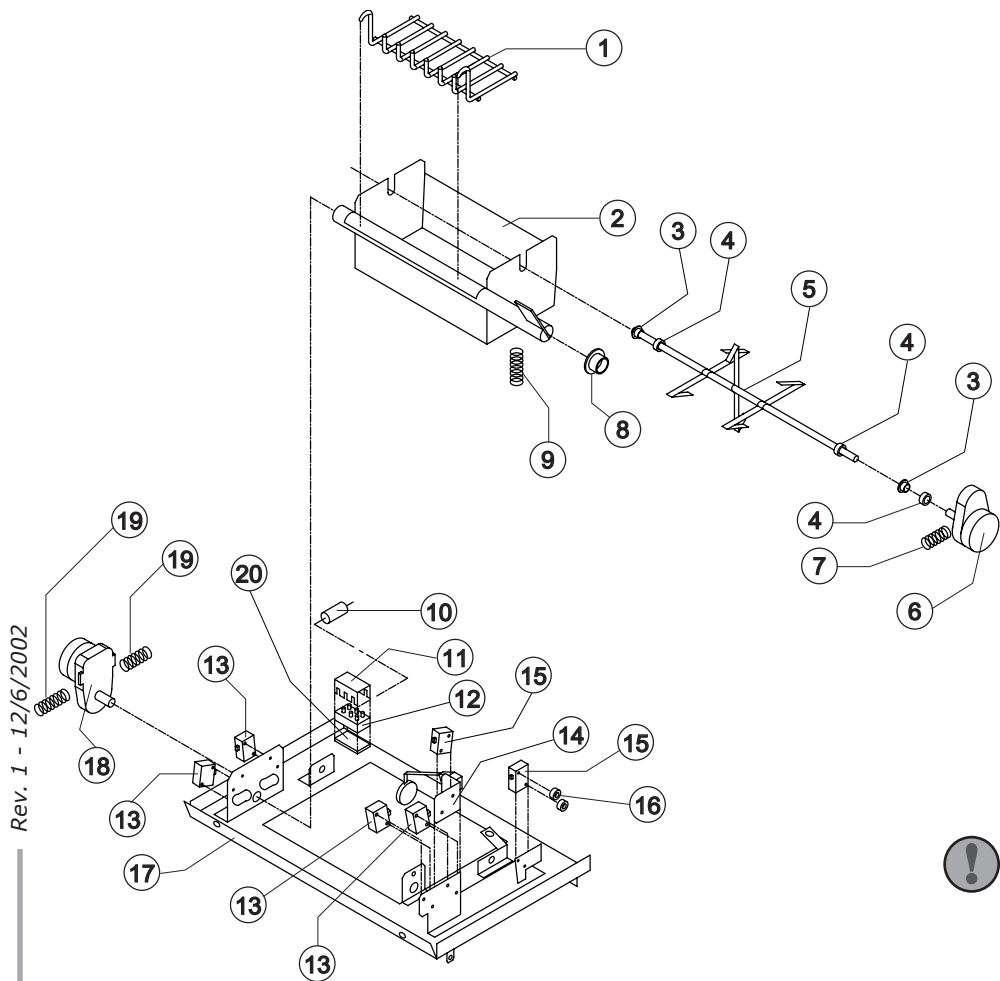

Rev. 1 - 12/6/2002

Ref.	Spare Description	Code	
1	Internal Tray Slide	D12048	
2	Water Basin with Pin	C22356	
3	Self-Lubricating Bush 06/06	20230	
4	Shaft Stop Ring	20227	
5	Shaft with Paddles	20221	
6	Gearmotor (for Paddles)	23194	
7	Spring (Support Gearmotor)	20228	
8	Self-Lubricating Bush 12/07	20231	
9	Spring(Basin Lightening)	20282	
10	Condenser 0,12 µF - 1000 V	220/240V 50 Hz	23318
10	Condenser 0,15 µF - 1000 V	220/230V 60 Hz	23329
11	Terminal Cover	23250	
12	Terminal	23249	
13	Microswitch (usually closed)	23196	
14	Working Kit for the Floating Micro	C26562	
15	Microswitch (usually open)	23372	
16	Switch Shimming Ring	10250	
17	Evaporator Support Plate	22351	
18	Gearmotor (for Turnover Basin)	See Table	-
19	Spring (Support Gearmotor)	20232	
20	Terminal Board Spacer	10143	

! The Complete Evaporator Support Plate has to be request, making reference to the Table.

Evaporator Support Plate

Tension	Code
220/240V 50 Hz	C22351
220/230V 60 Hz	C22696

Ref. 18 - Gearmotor (for Turnover basin)

Tension	Code
220/240V 50 Hz	23195
220/230V 60 Hz	23581

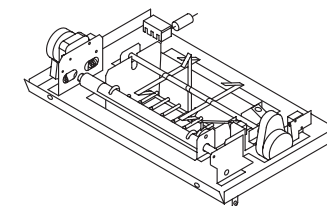



IF 55

ELECTRIC PARTS

Common Parts

Ref.	Spare Description	Code
1	Fan Motor	23029
2	Hot Gas Coil	23091
3	Anti Radio Interference Filter	220/240V 50 Hz 23458
4	Hot Gas Valve Body	20410
5	Condenser Pressure Switch	23175
6	Bin Thermostat	23005
7	Anti Radio Interference Filter	220/240V 50Hz 23459
8	Relay	23190
9	Green Light Switch	23327

Parts for Air-Cooled Version Only

Ref.	Spare Description	Code
12	Inlet Watervaleve 1 Way	23220

Parts for Water-Cooled Version Only

Ref.	Spare Description	Code
10	Safety Thermostat	C23114
11	Inlet Watervaleve 2 Ways	C23507

Rev. 1 - 12/6/2002

