

**FRITADEIRA FF10 NV**
FRYER FF10 NV**FRITADEIRA FF10 NV FIAMMA - 2.0.087.1000**
FRYER FF10 NV FIAMMA**POTÊNCIA** **3500 W**
*POWER***TENSÃO DE ALIMENTAÇÃO** **220-240V/50Hz**
*POWER SUPPLY***TERMOSTATO REGULÁVEL** **90-180 °C**
*ADJUSTABLE THERMOSTAT***PRODUTIVIDADE** **13 kg/h**
*PRODUCTIVITY***PESO LIQUIDO** **8 kg**
*NET WEIGHT***PESO BRUTO** **9 kg**
*GROSS WEIGHT***DIMENSÕES (LxPxH)** **265x475x375 mm**
*DIMENSIONS (LxPxH)***DIMENSÕES DA EMBALAGEM (LxPxH)** **300x540x420 mm**
*PACKAGE DIMENSIONS***DIMENSÕES DO CESTO (LxPxH)** **220x250x104 mm**
*BASKET DIMENSIONS***CAPACIDADE DE ÓLEO** **8 L**
OIL CAPACITY

FRITADEIRA FF10 NV

FRYER FF10 NV

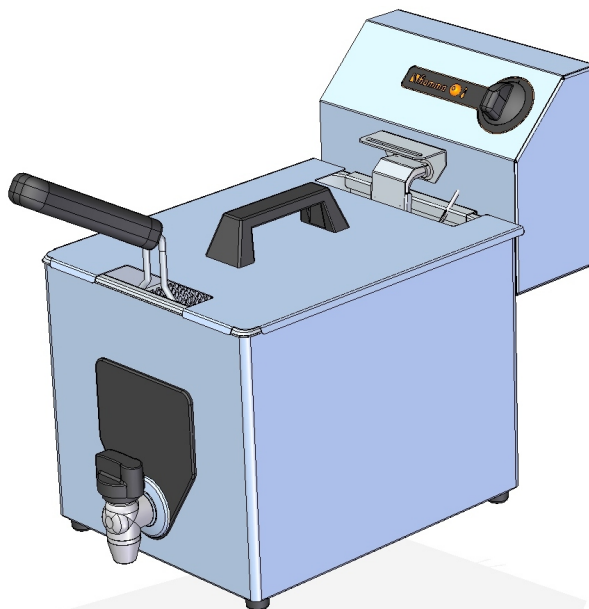
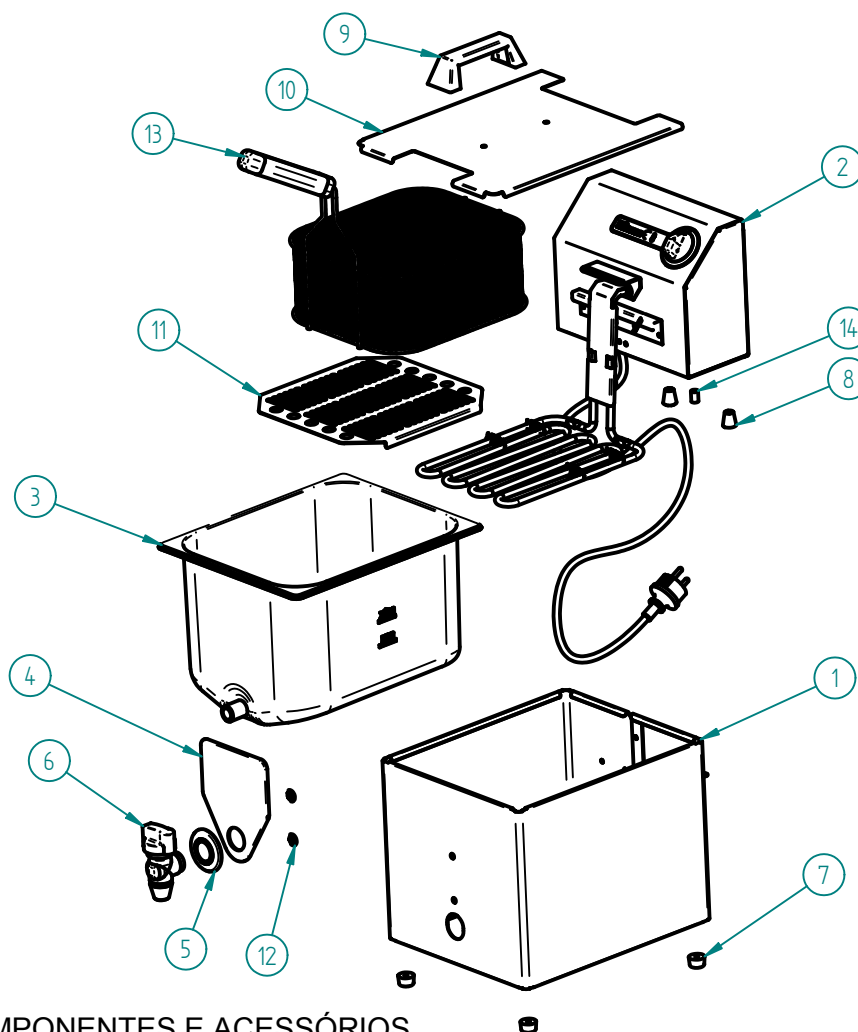

LISTA DE COMPONENTES E ACESSÓRIOS Spare parts list

ITEM Nº	CÓDIGO	DESIGNAÇÃO	DESIGNATION	QUANT.
1	7.0.087.1005	BLINDAGEM CONJUNTO FF10 NV	SHIELDS ASS. FF10 NV	1
2	7.0.087.1000	CABEÇOTE MONTADO FF10 NV	ELECTRIC UNIT ASS. FF10 NV	1
3	4.0.087.1029	CUBA GN1/2 H210mm C/ RACORD FF10 NV	TANK GN1/2 H210MM FF10 NV	1
4	4.0.087.0034	PROTECÇÃO TERMICA TORNEIRA FF	THERMIC TAP PROTECTION	1
5	4.0.087.0032	ESPELHO CROMADO 3/4"	CHOMED MIRROR 3/4"	1
6	4.0.087.0030	TORNEIRA G1/2	TAP G1/2F	1
7	4.2.000.9246	BATENTE PRETO Nº2	BLACK KNOCKER NR. 2	4
8	4.0.085.0027	MANIPULO FRITADEIRAS (M5)	HANDLE (M5)	2
9	4.1.000.6220	PEGADEIRA REF. 58 EM PVC	PVC HANDGRIP	1
10	7.0.085.1060	TAMPA CUBA FF6 NV / FF10 NV	TANK COVER FF6 NV / FF10 NV	1
11	7.0.087.1070	GRELHA PROTECÇÃO RESIST. FF10 NV	HEATING ELEMENT PROTECTION GRID FF10 NV	1
12	4.0.087.0040	ANILHA FIXAÇÃO RÁPIDA 6MM	FIXING RING 6MM	2
13	4.0.085.1031	CESTO CONJ. FF6 NV/FF10 NV	BASKET FF6 NV/FF10 NV	1
14	4.0.028.0035	CASQUILHO GUIA TAB. SUP. PACIFIC	BUSHING GUIDE TRAY TOP PACIFIC	1

FRITADEIRA FF10 NV

FRYER FF10 NV

2 - CABEÇOTE MONTADO FF10 NV - 7.0.087.1000

2 - ELECTRIC UNIT ASS. FF10 NV

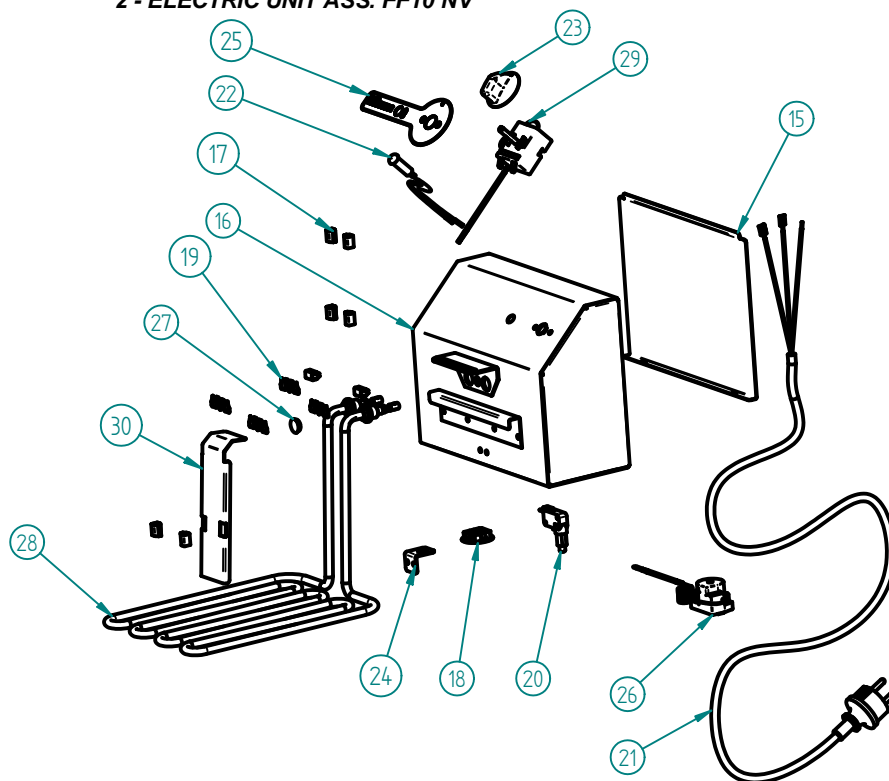

LISTA DE COMPONENTES E ACESSÓRIOS

Spare parts list

ITEM Nº	CÓDIGO	DESIGNAÇÃO	DESIGNATION	QUANT.
15	7.0.085.0050	TAMPA CASTELO FF	COVER FOR ELECTRIC UNIT FF	1
16	7.0.085.1025	CASTELO CONJUNTO FF6 NV/FF10 NV	SHIELD OF ELECTRIC UNIT FF6 NV/ FF10 NV	1
17	4.0.085.0017	MOLA P/ CAPILARES	WIRE SPRING	8
18	4.2.000.9457	CERRA CABOS PA 107 - AD 003	CABLE FASTENER PA107 - AD 003	1
19	4.0.085.0114	MOLA ARAME P/ BOLBO	SPRING	4
20	4.0.085.0021	MICRO INTERRUPTOR RLP/A	MICRO SWITCH RLP/A	1
21	4.0.085.0070	CABO H07RN-F 3G1,5 - 1,5MT C/ FICHA+TERM.	CABLE H07RN-F 3G1,5 - 1,5MT W/ PLUG	1
22	4.0.085.0022	SINALIZADOR LARANJA TER. PONT. 250MM SL10207	ORANGE LED 250MM	1
23	4.0.075.0040	MANIPULO TEMPORIZADOR	BUTTON	1
24	7.0.085.1026	FIXADOR MICRO INTERRUPTOR FF NV	MICRO SWITCH FIXER	1
25	4.0.190.0050	PAINEL PERSONALIZADO FIAMMA FCF	STICKER FCF FIAMMA	1
26	4.0.085.0011	TERMOSTATO SEGURANÇA 220°	SAFETY THERMOSTAT 220°C	1
27	4.0.085.0035	TAPA FUROS Ø10MM	RUBBER COVER Ø10MM	1
28	4.0.087.1005	RESISTÊNCIA 3500W-230V FF10 NV	HEATING ELEMENT 3500W-230V FF10 NV	1
29	4.0.085.0009	TERMOSTATO REGULAVEL 180°	ADJUSTABLE THERMOSTAT 180°C	1
30	7.0.085.1067	BLINDAGEM CAPILARES FF NV	CAPILLARY SHIELD FF NV	1

FRITADEIRA FF10 NV**FRYER FF10 NV**ESQUEMA ELECTRICO
Electric Scheme