



ELECTRIC OVEN  
ELEKTROBACKOFEN  
FOUR ÉLECTRIQUE  
HORNO ELÉCTRICO  
FORNO ELÉCTRICO  
FORNO ELETTRICO

GAS OVEN  
GASBACKOFEN  
FOUR À GAZ  
HORNO DE GAS  
FORNO A GÁS  
FORNO A GAS

OVEN WITH BOILER  
BACKOFEN MIT BOILER  
FOUR AVEC CHAUFFE-EAU  
HORNO CON BOILER  
FORNO COM BOILER  
FORNO CON BOILER

DIRECT OVEN  
DIREKTER BACKOFEN  
FOUR DIRECT  
HORNO DIRECTO  
FORNO DIRECTO  
FORNO DIRETTO

OVEN WITH WASH CYCLE  
BACKOFEN MIT SPÜLUNG  
FOUR AVEC LAVAGE  
HORNO CON CICLO DE LAVADO  
FORNO COM LAVAGEM  
FORNO CON LAVAGGIO

OVEN WITH CORE PROBE  
BACKOFEN MIT KERNFÜHLER  
FOUR AVEC SONDE À CŒUR  
HORNO CON Sonda Térmica  
FORNO COM SONDA NO NÚCLEO  
FORNO CON Sonda AL CUORE

OVEN WITH TROLLEY  
BACKOFEN MIT TROLLEY  
FOUR AVEC TROLLEY  
HORNO CON TROLLEY  
FORNO COM TROLLEY  
FORNO CON TROLLEY

## DRIVE 110

REV. 01 - 12/09:

MODIFICATO IMPIANTO IDRAULICO (GAS ED ELETTRICO) - AGGIUNTO FILTRI (ELETTRICO) E FERRITE (ELETTRICO) - AGGIORNATO BASAMENTI PER 610 E 210 - SOSTITUITO INIETTORE UMIDIFICATORE - SOSTITUITO MOTORINO APERTURA VALVOLA E RELATIVI COMPONENTI - SOSTITUITO ELETTROVALVOLA E RELATIVI COMPONENTI (SOLO LAVAGGIO) - SOSTITUITO CENTRALINA ACCENSIONE FORNO (SOLO GAS) - AGGIUNTA PARATIA PARA SPRUZZI

REV. 2010:

AGGIUNTE GRIGLIE SOTTO BASAMENTO - MODIFICATO FIANCO DX, POSTERIORE E CIELO (ELETTRICO) - AGGIUNTA PARATIA VENTOLA BASAMENTO (SOLO GAS) - MODIFICATO LAVAGGIO TOURNIQUETTE (RACCORDO + TUBO TEFLON) - SOSTITUITO TUBO CARICO BOILER - AGGIUNTO SISTEMA BLOCCO PORTA

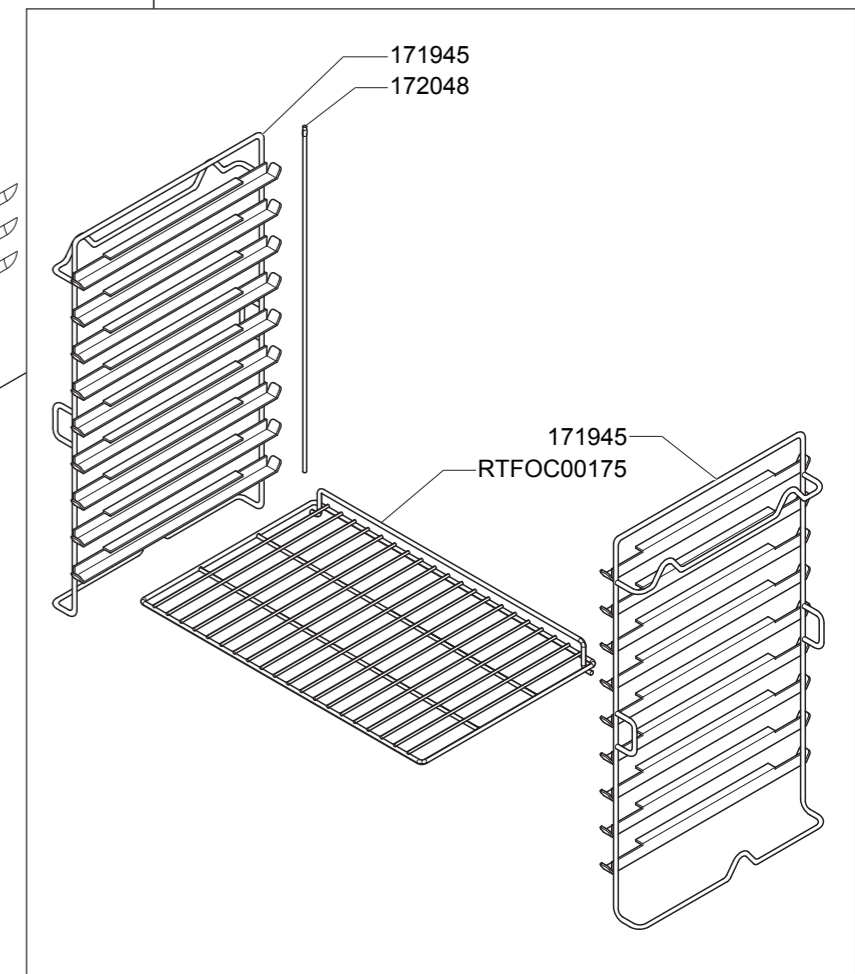
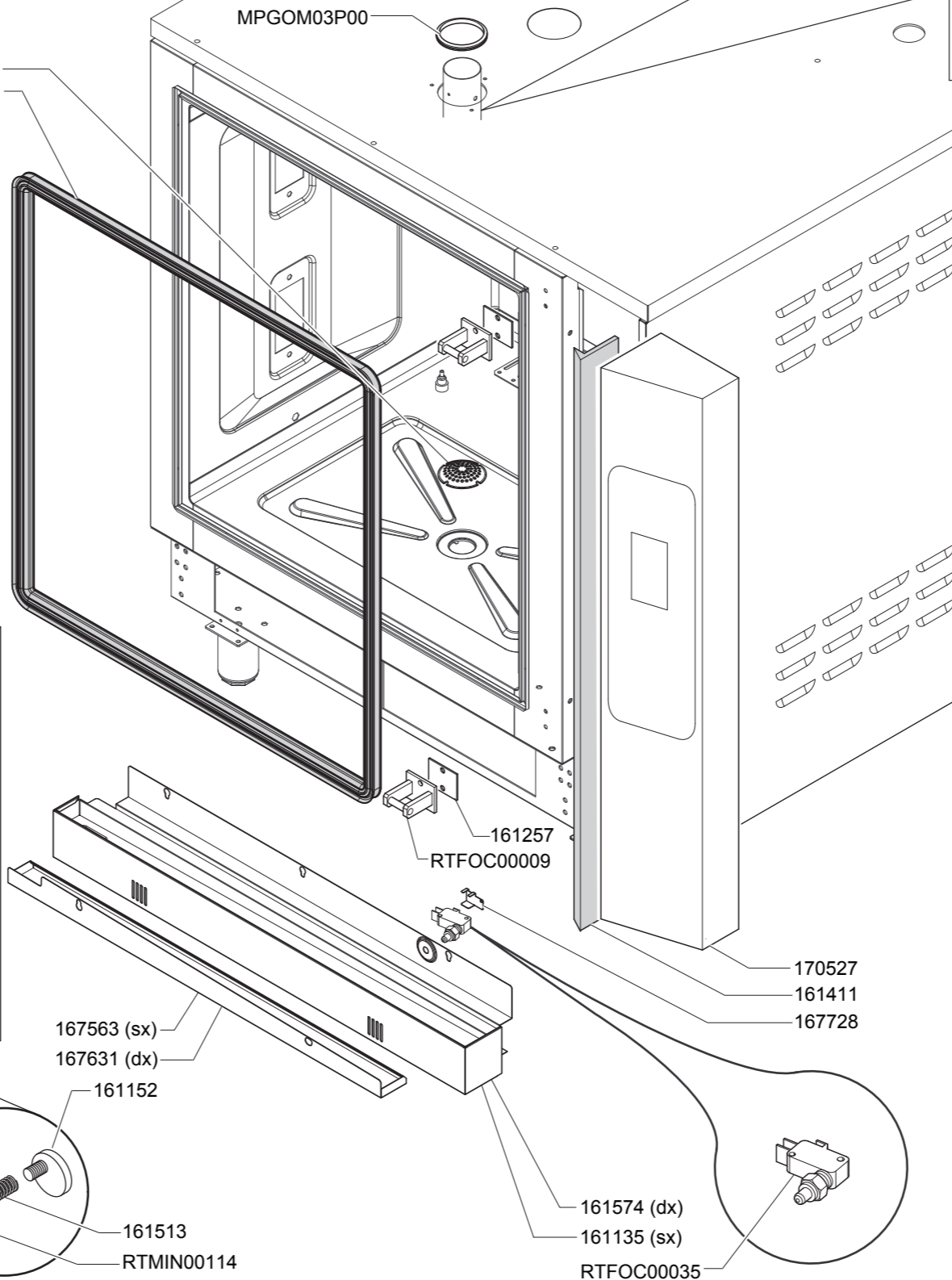
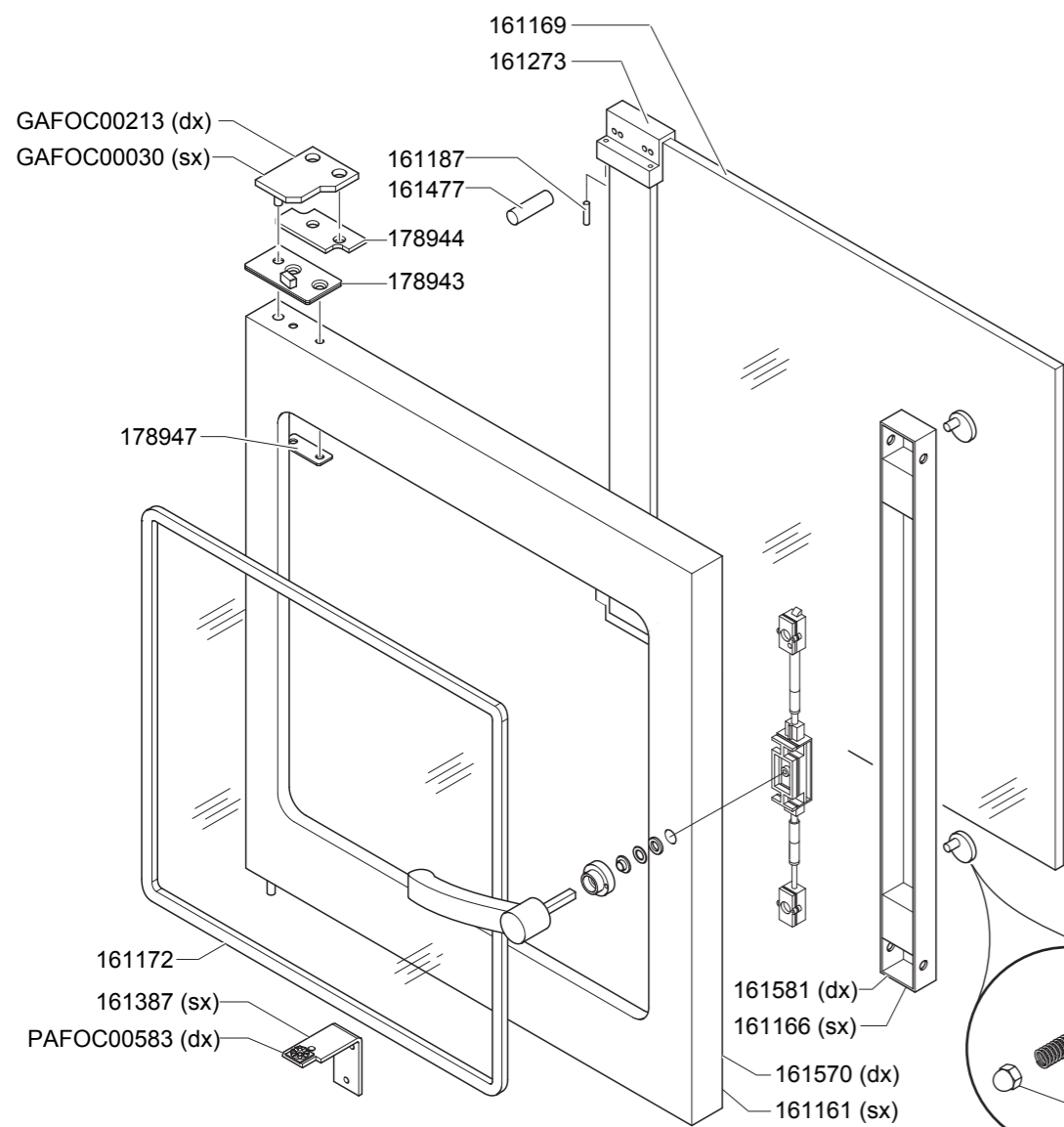
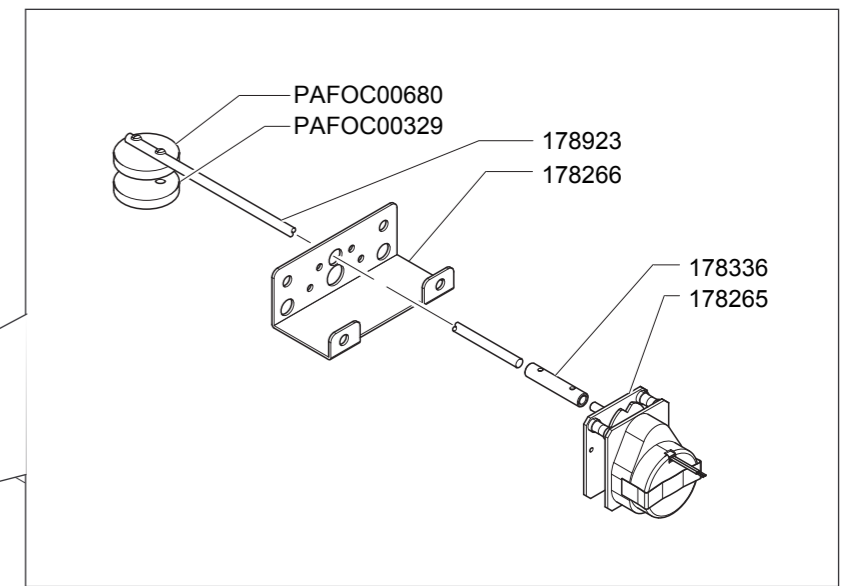
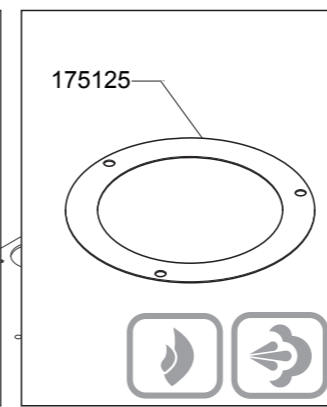
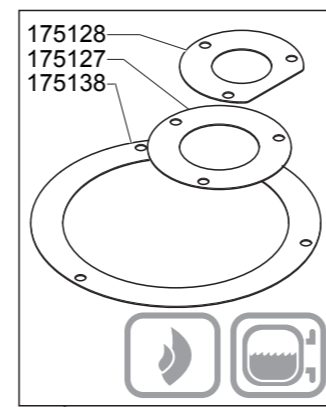
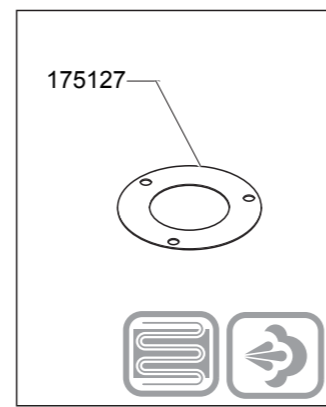
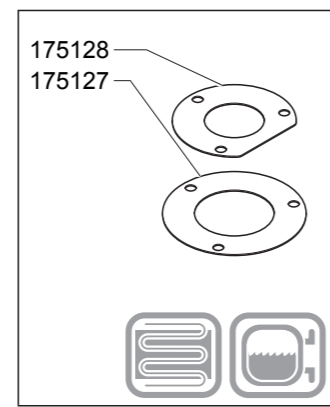
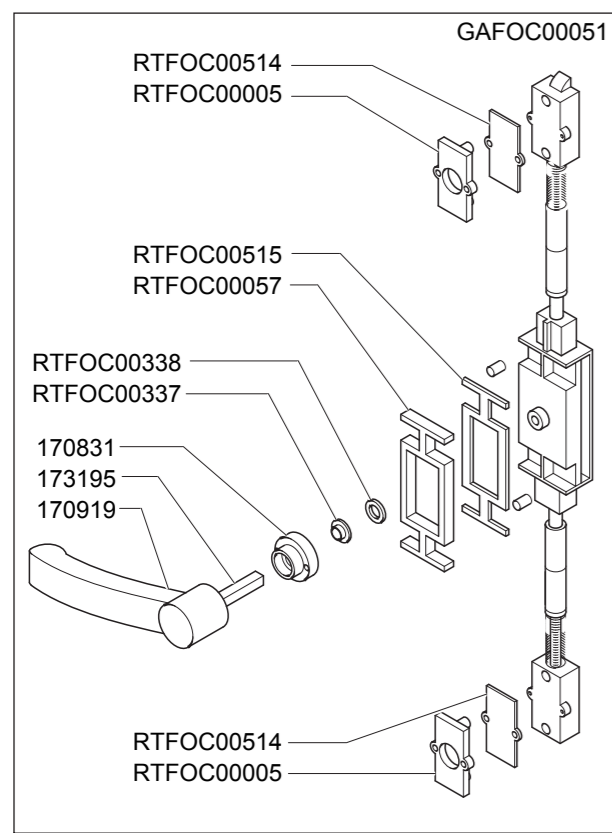

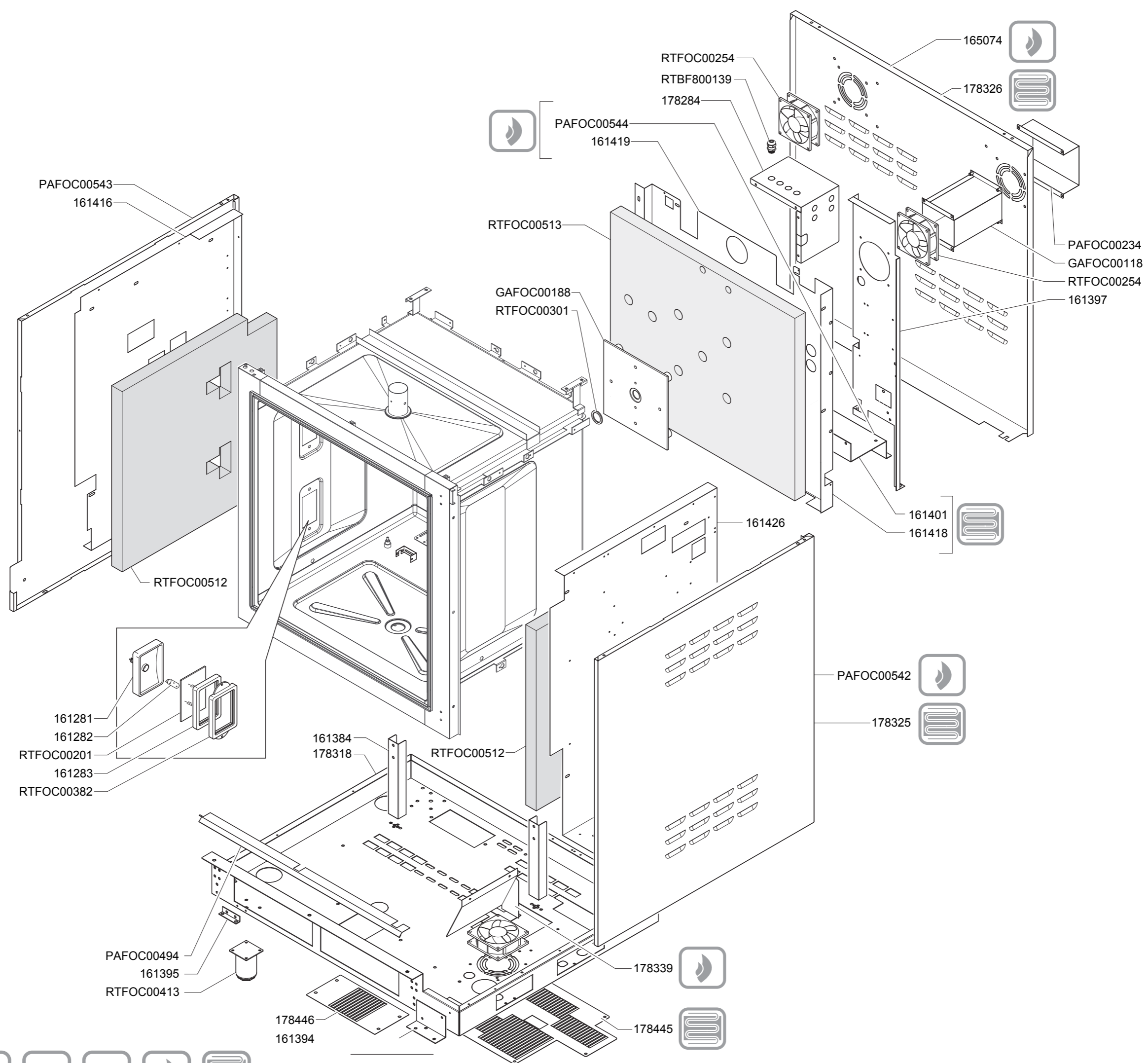

**DRIVE 110**

**TAV.2**

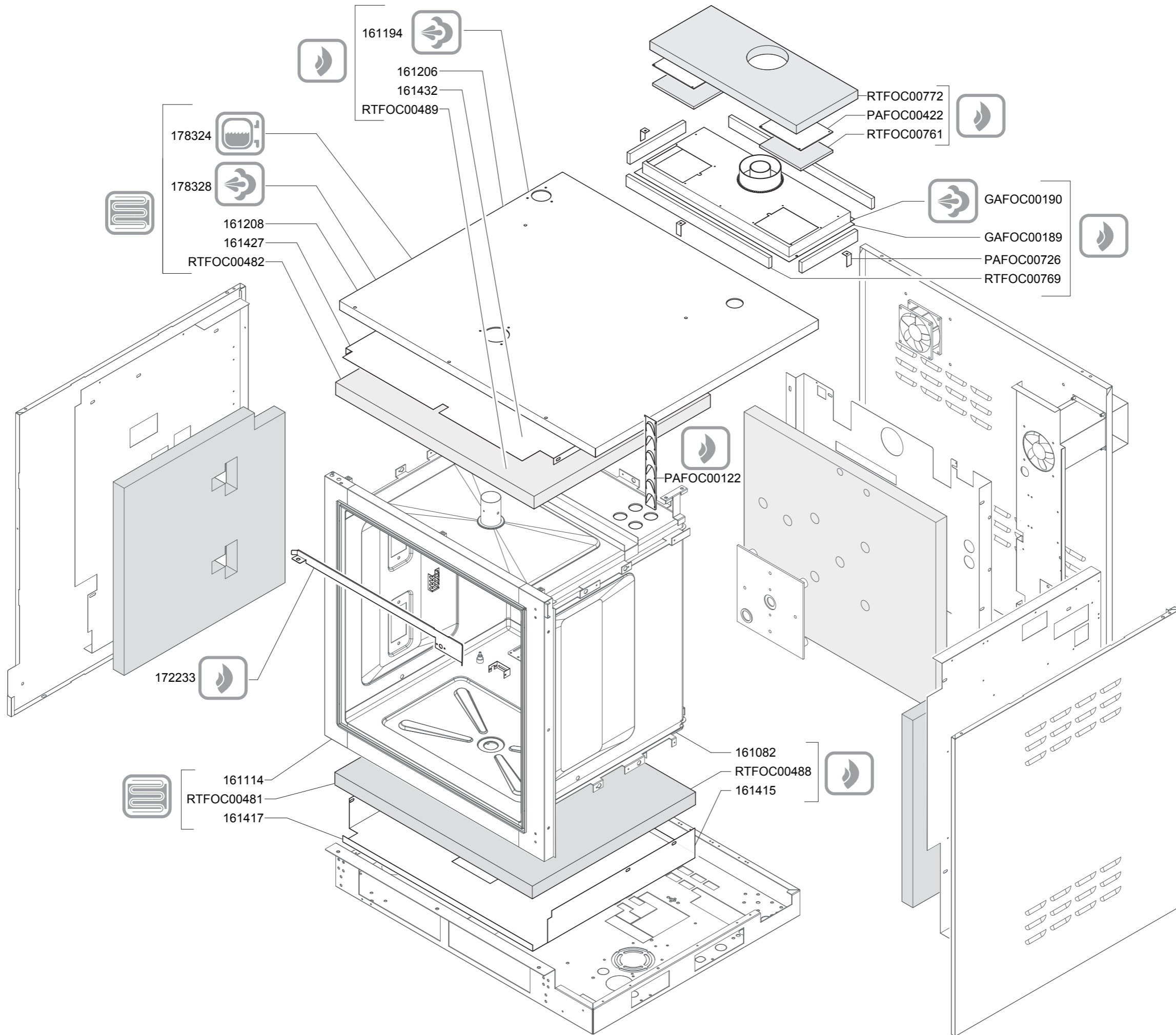

**DRIVE 110**

**TAV.2A**

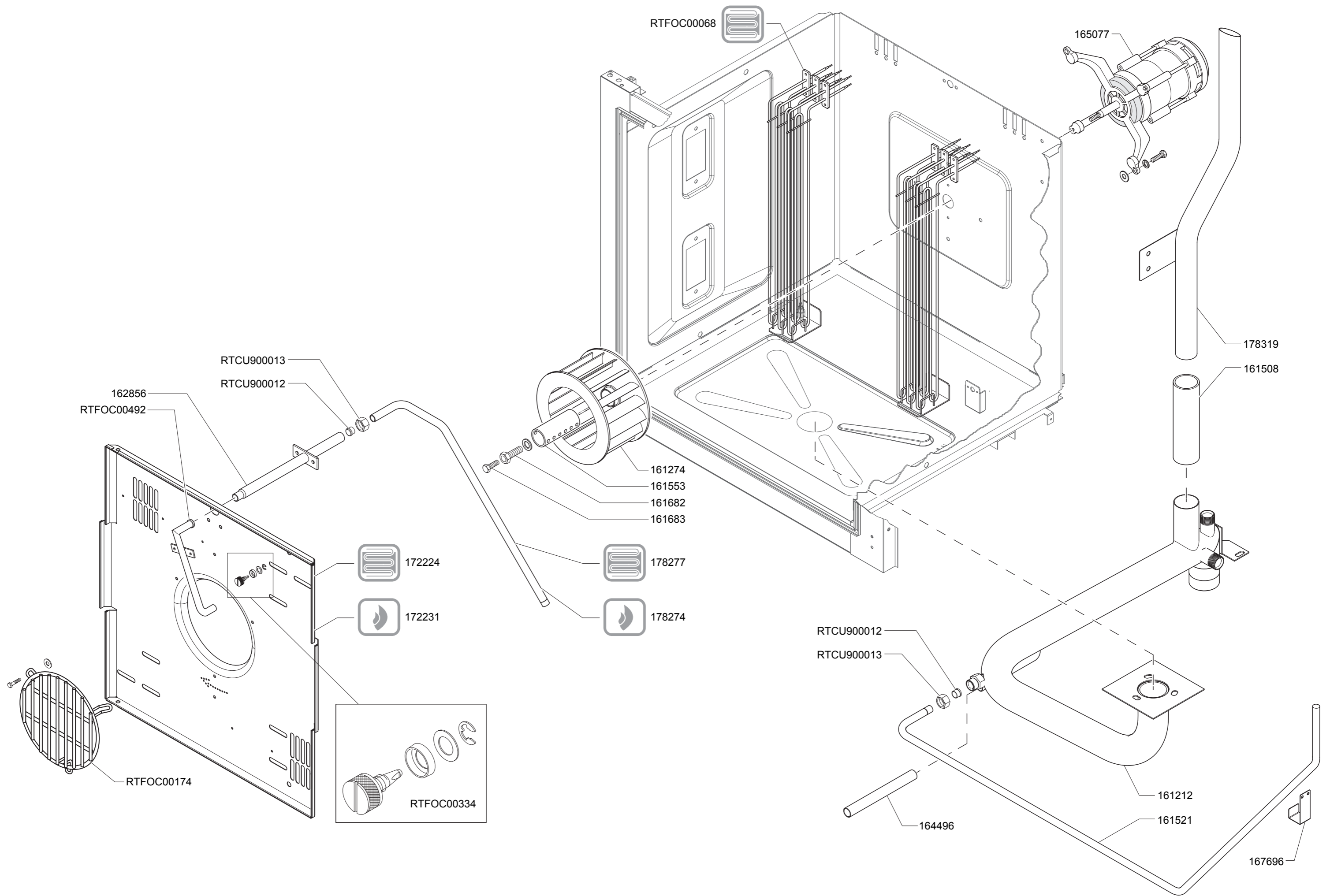

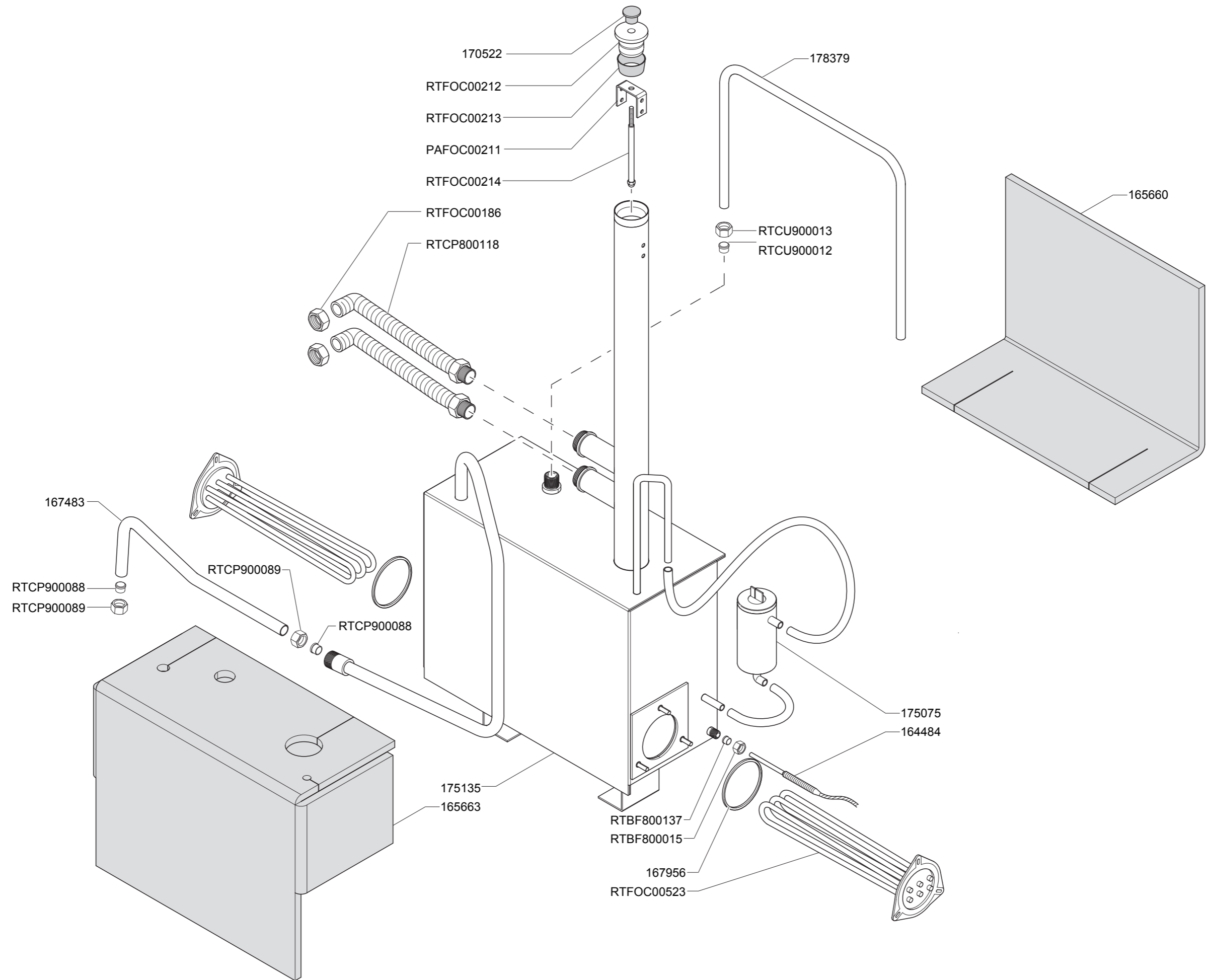

**DRIVE 110**

**TAV.4**

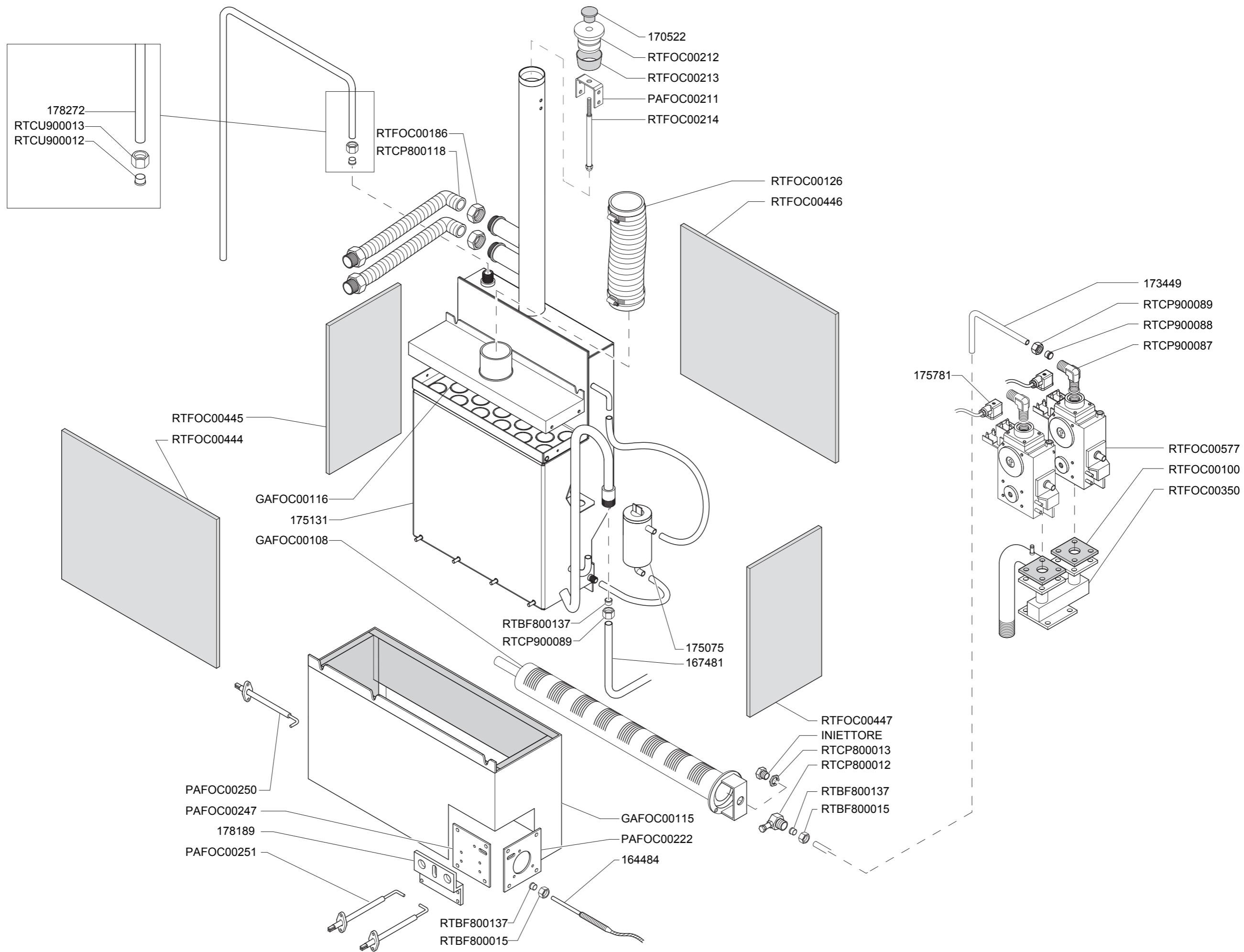

**DRIVE 110**

**TAV.5**

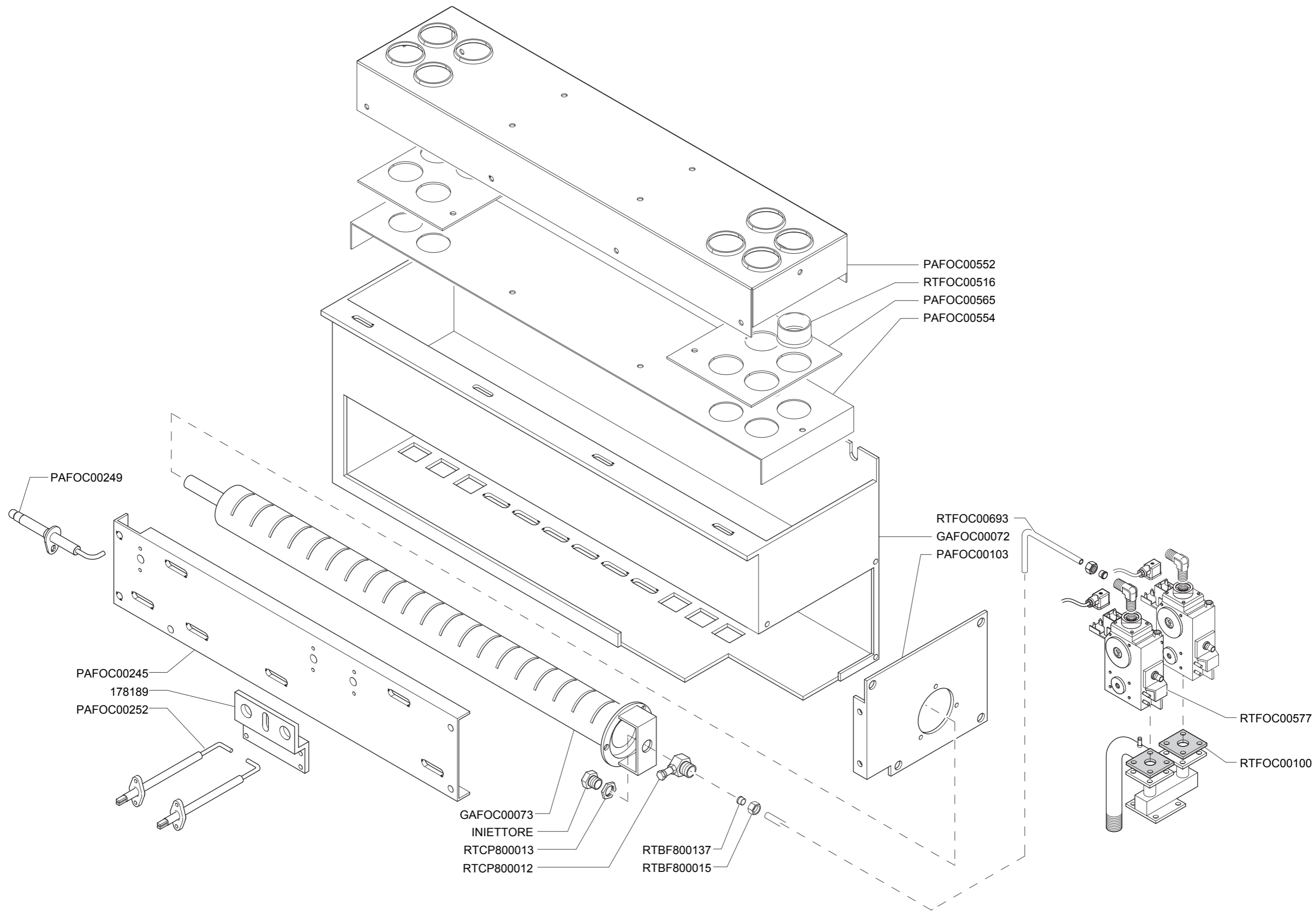

**DRIVE 110**

**TAV.5A**



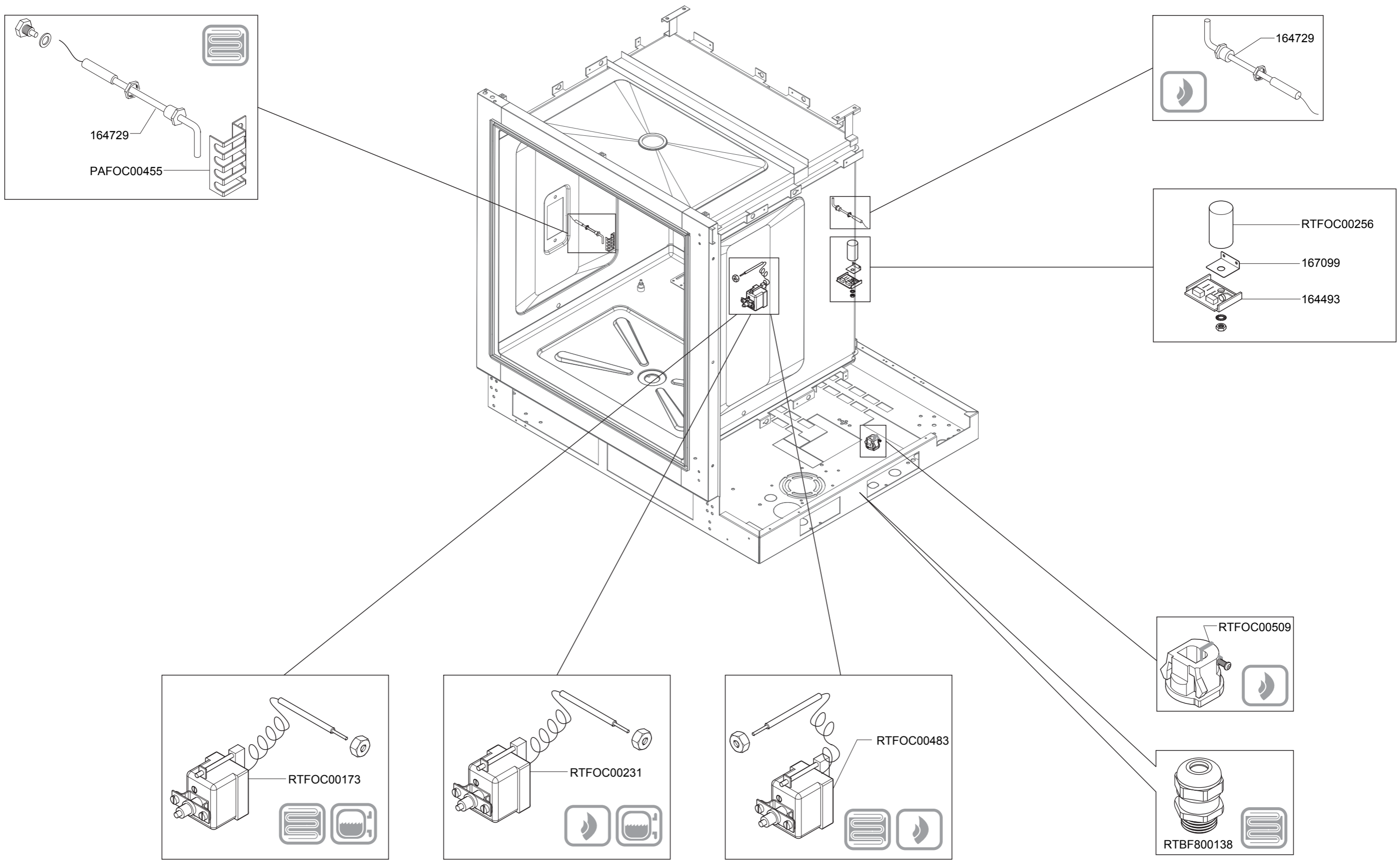

**DRIVE 110**

**TAV.6**

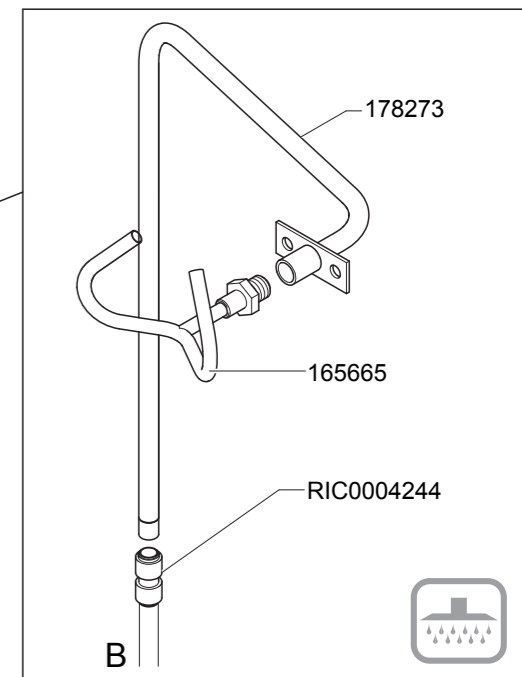
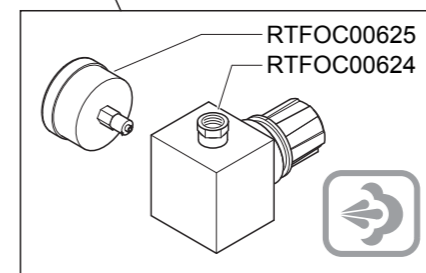
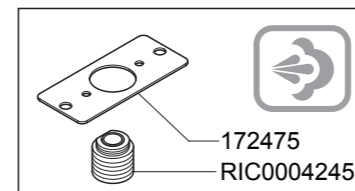
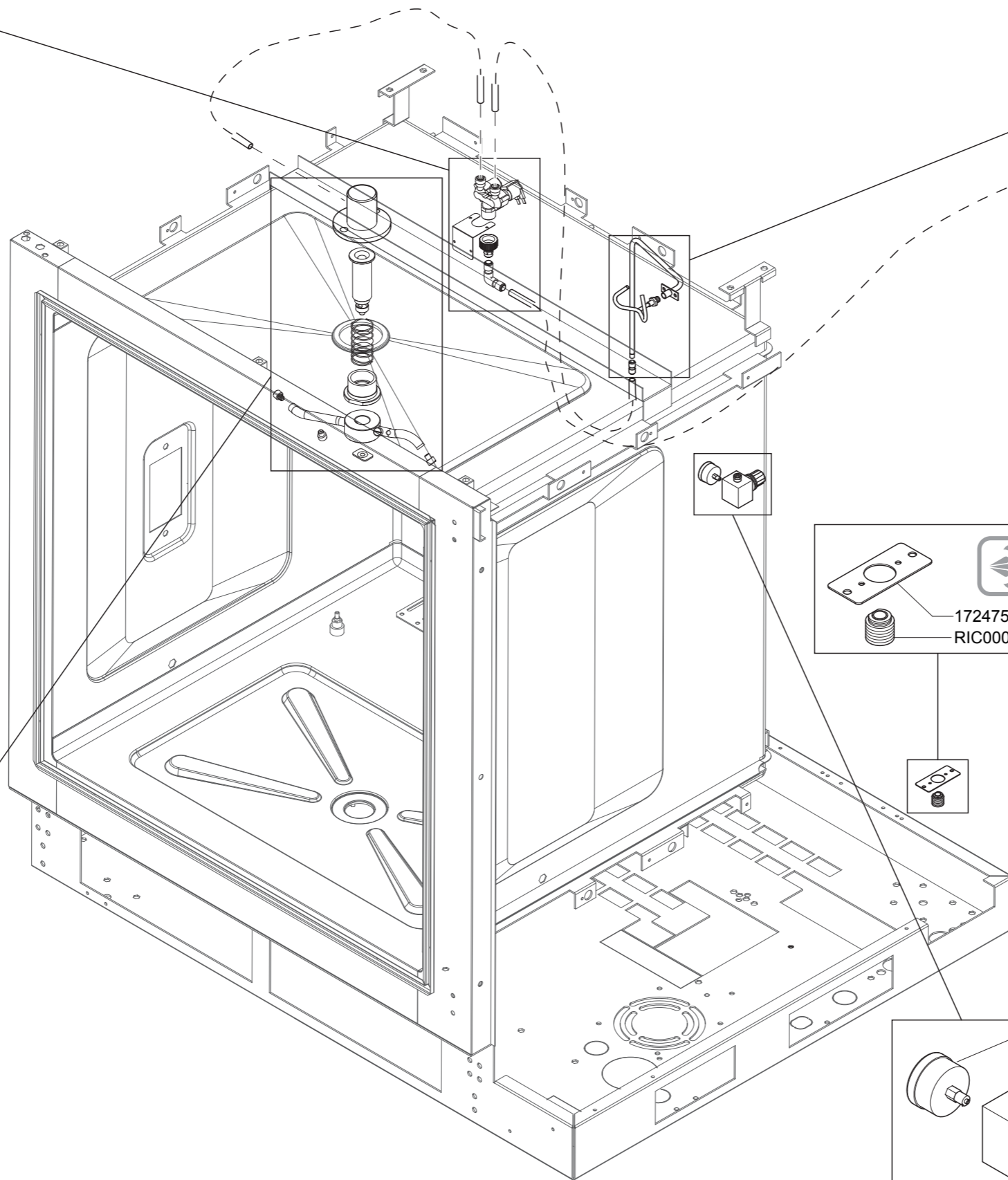
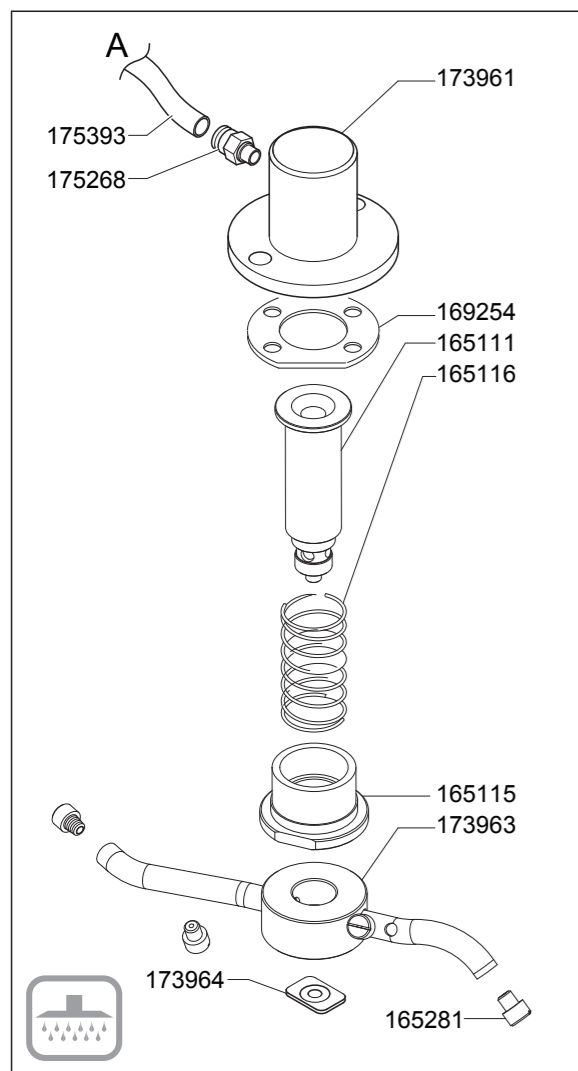
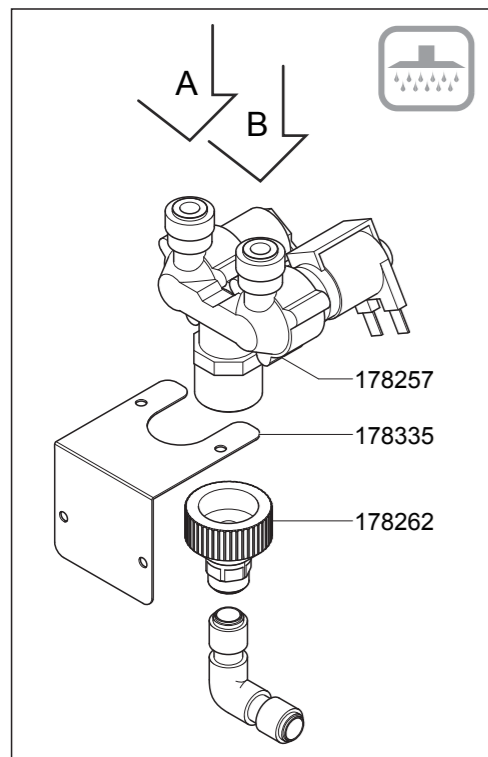

172657

RIC0003962

175352  
175350  
175352

172655  
175393

167137  
165285

165597



**DRIVE 110**

**TAV.6A**

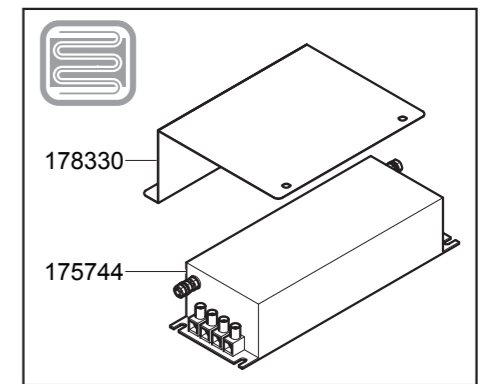
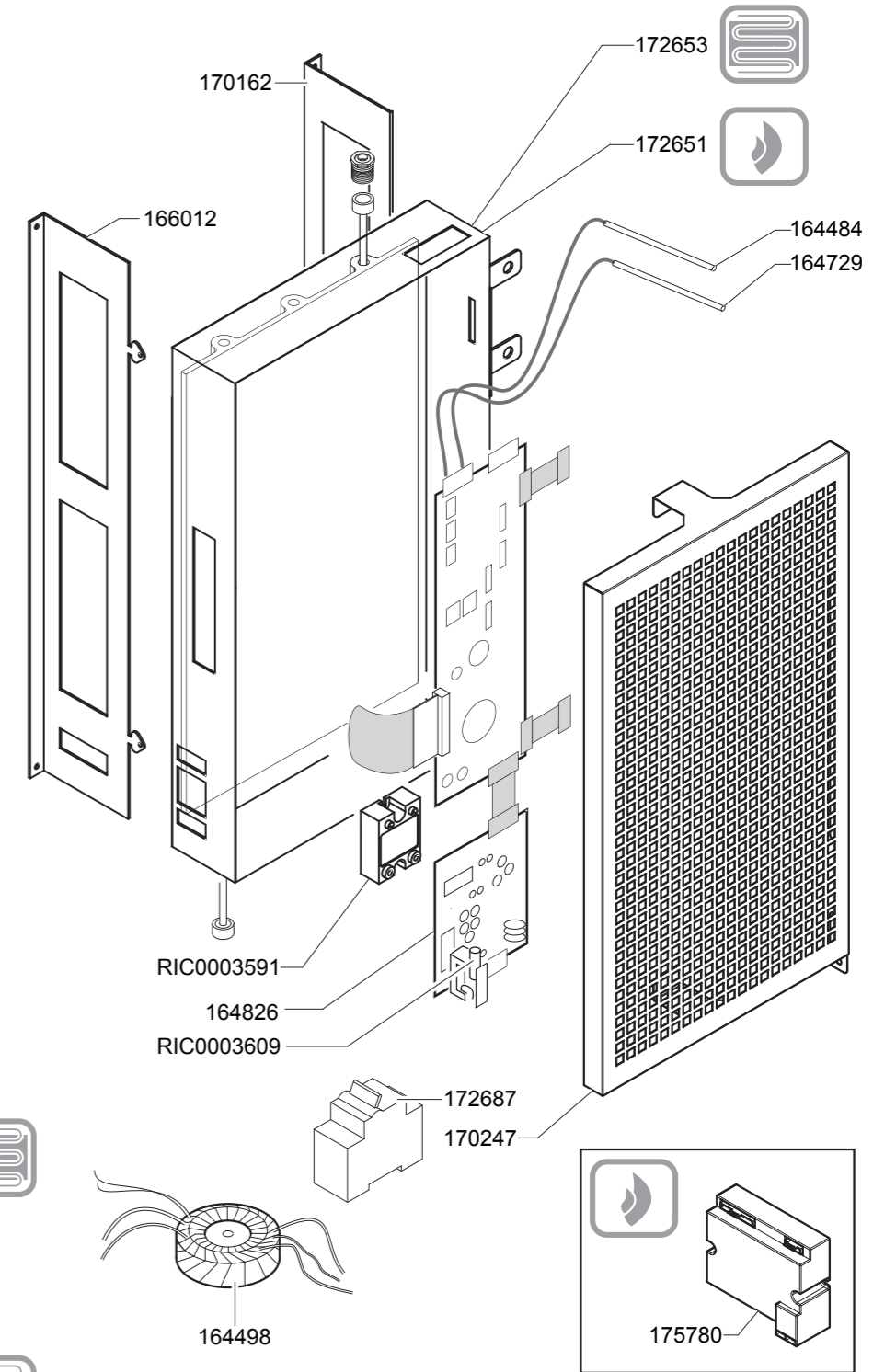
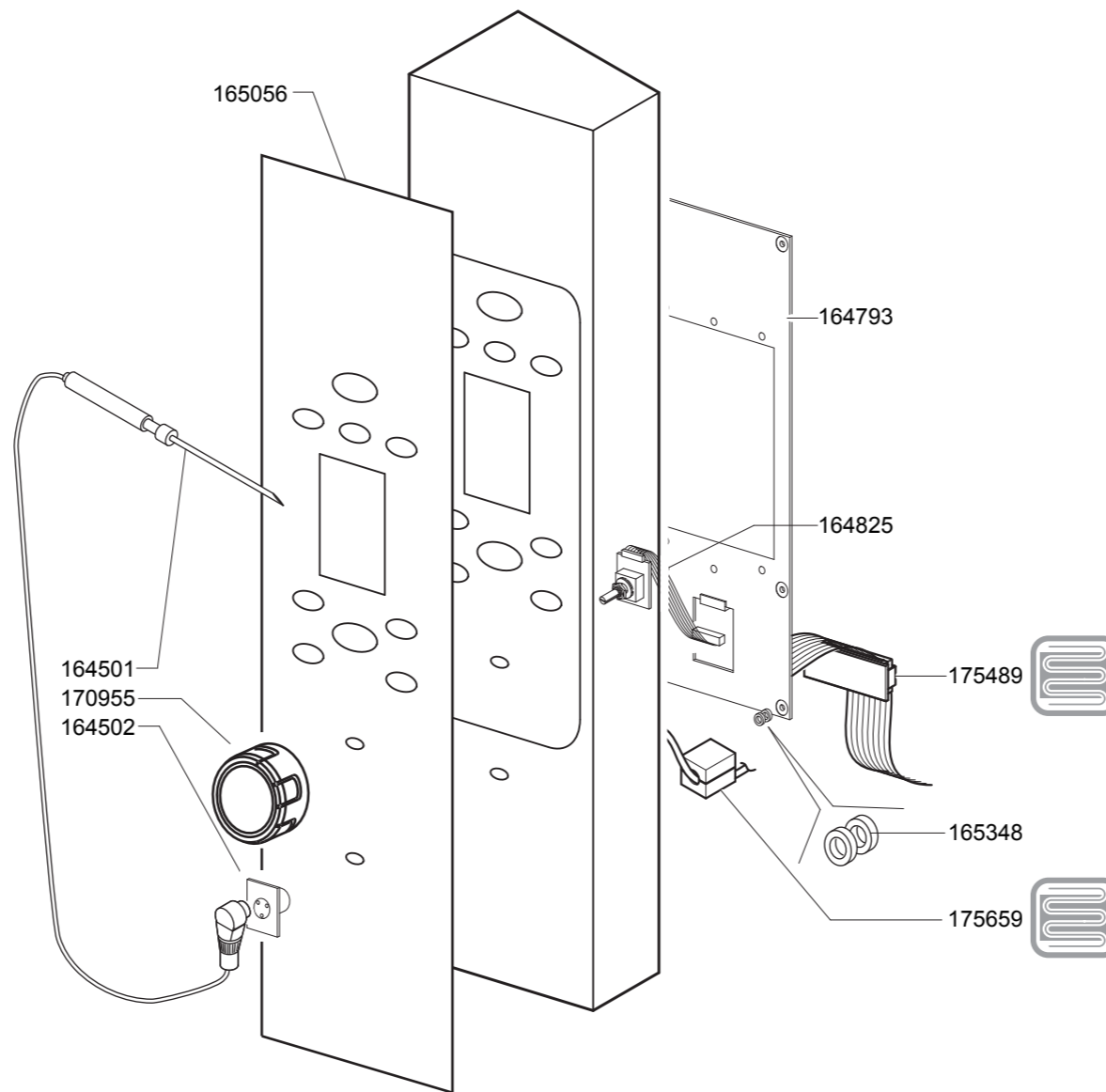
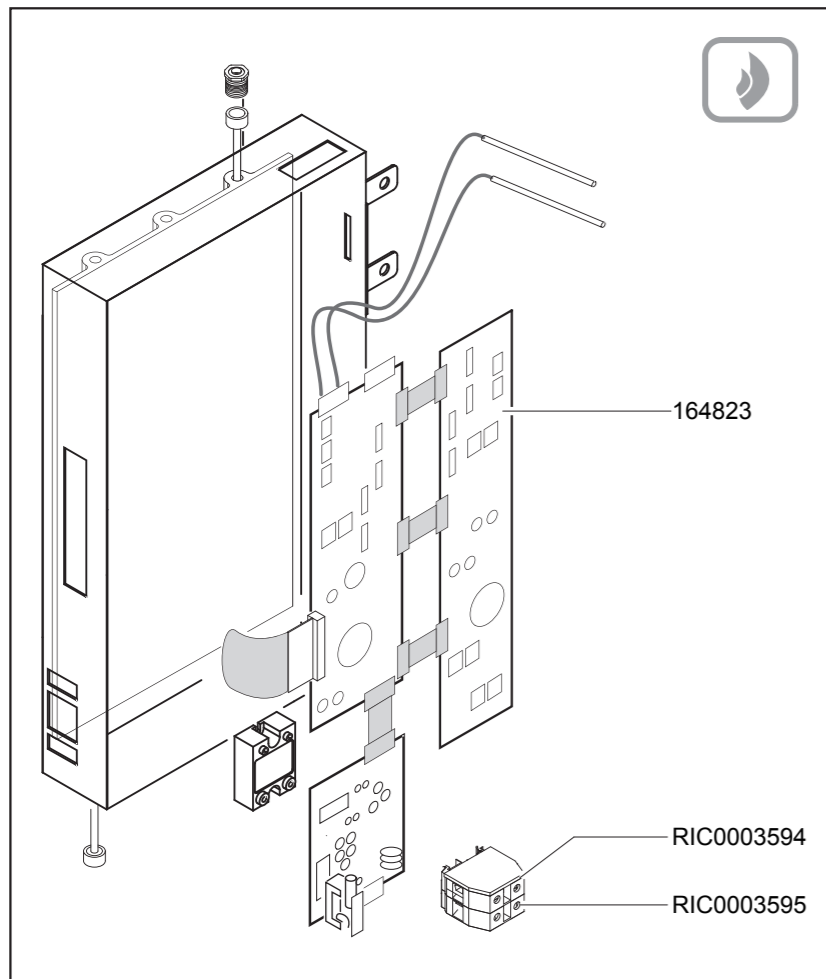
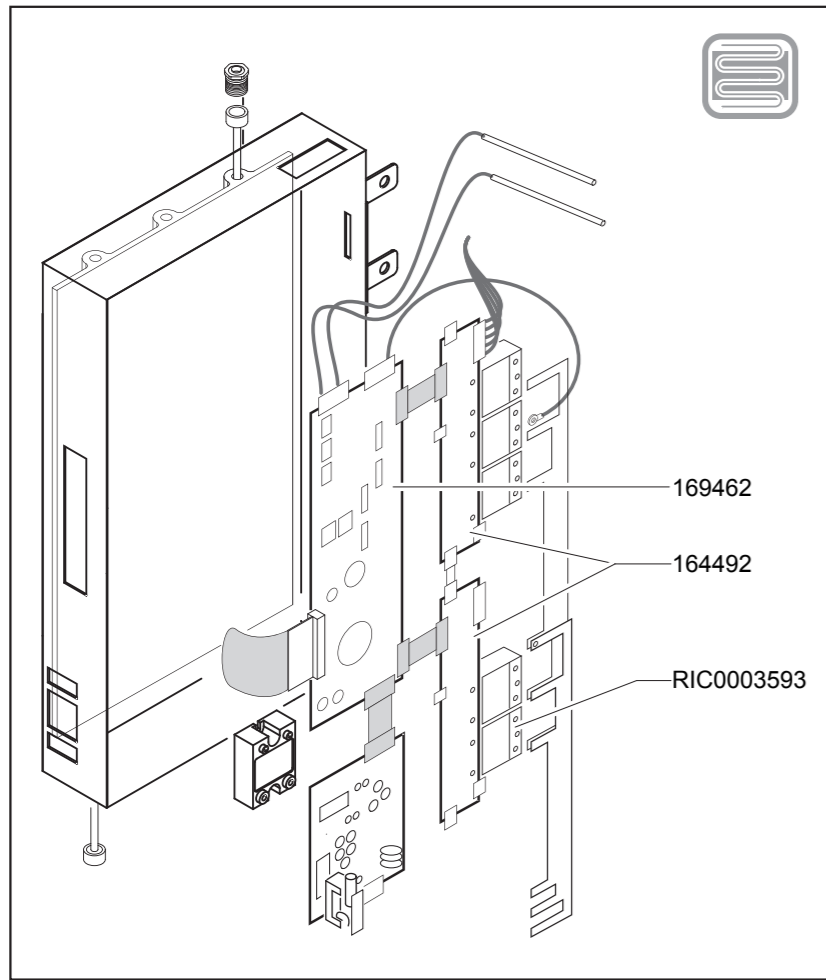

**DRIVE 110**

**TAV.7**

**SPARE PARTS - ERSATZTEILE - PIÈCES DE RECHANGE  
RECAMBIOS - PEÇAS SOBRESSALENTES - RICAMBI**

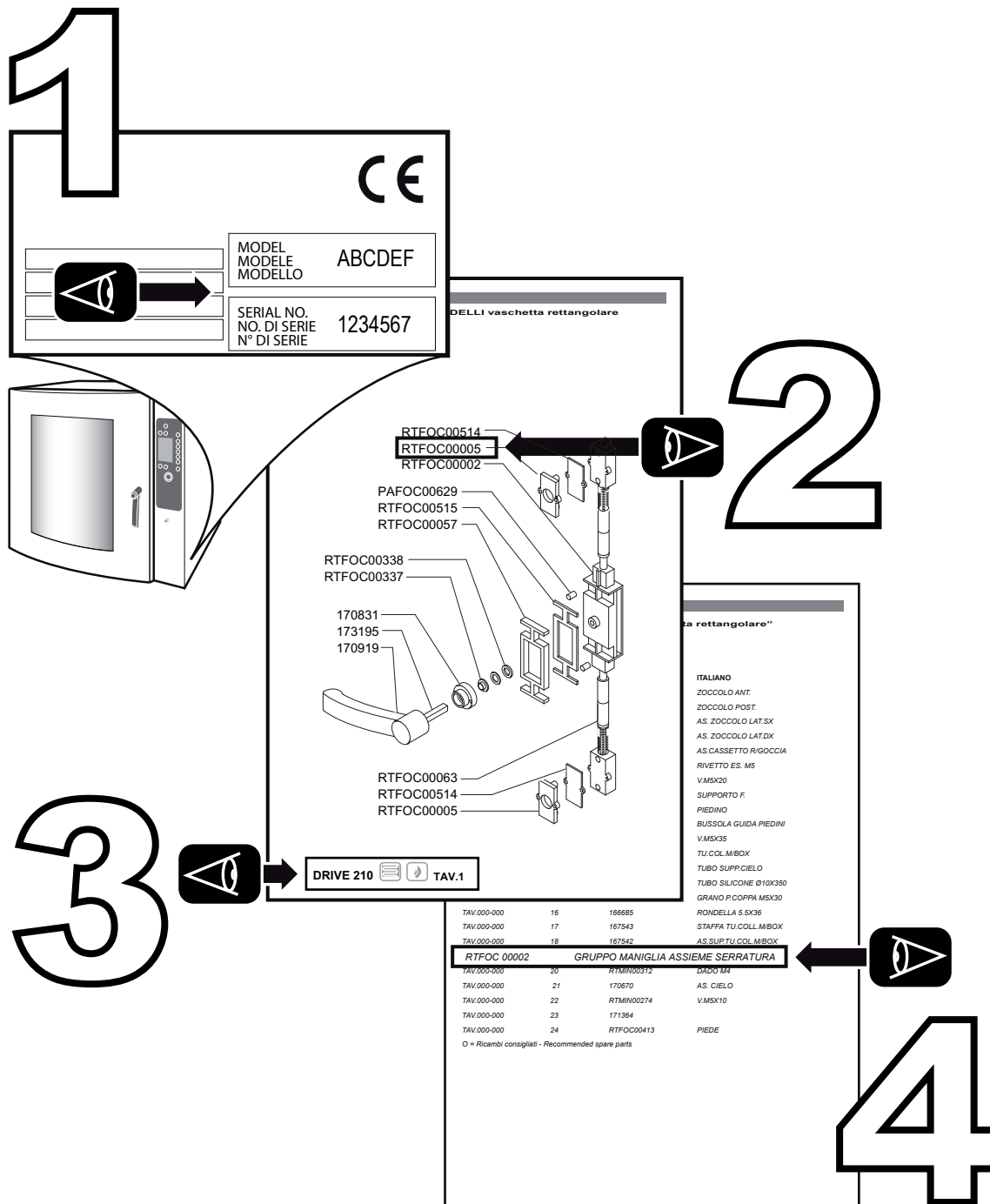

**In order to correctly request the spare part needed, the following data must be supplied:**

- 1) Model-Series
- 2) Position/Special code
- 3) Table number
- 4) Product code- Quantity needed

**Für eine korrekte Bestellung des gewünschten Ersatzteils müssen folgende Daten angegeben werden:**

- 1) Modell - Serie
- 2) Position/Teilenummer
- 3) Tafelnummer
- 4) Artikelnummer- gewünschte Menge

**Pour commander la pièce de rechange souhaitée, il est nécessaire de fournir les données suivantes:**

- 1) Modèle - Série
- 2) Position/Code du détail
- 3) Numéro du tableau
- 4) Code du produit - Quantité souhaitée

**Para solicitar correctamente la pieza de recambio deseada, es necesario facilitar los siguientes datos:**

- 1) Modelo-Serie
- 2) Posición/Código del componente
- 3) Número de la tabla
- 4) Código del producto - Cantidad deseada

**Para poder encomendar correctamente a peça sobressalente desejada, é necessário fornecer os dados a seguir:**

- 1) Modelo - Série
- 2) Posição/Código da parte
- 3) Número da tabela
- 4) Código do produto - Quantidade desejada

**Per poter richiedere correttamente il pezzo di ricambio desiderato, è necessario fornire i seguenti dati:**

- 1) Modello - Serie
- 2) Codice del particolare
- 3) Numero della tavola
- 4) Codice del prodotto - Quantità desiderata



COD.	IT	FR	GB	DE
161082	AS.CASSONE F.FGC100	ENSEMBLE CAISSON F.FGC200	CAVITY OVEN FGC200	KASTEN OFEN FGC200
161114	AS.CASSONE F.FEC100	ENSEMBLE CAISSON F.EL.	COOKING CHAMBER	KASTENGRUPPE ELEKTRO-BACKOFEN
161135	AS.CASSETTO SX.	BASSIN GAUCHE	TRAY LEFT	SCHUBLADE LINKS
161152	PERNO+GHIERA GUIDA MOLLA VETRO P.FV.	GROUPE BAGUE BLOCAGE VERRE	UNIT LUCKING GLASS NUT	GRUPPE GEFESTIGUNGSMUTTER GLAS
161161	AS.PORTA F.SX SERIE 100	PORTE FOUR GAUCHE SERIE 100	DOOR, OVEN LH SERIES 100	TÜR, OFEN LINKS REIHE 100
161166	AS.PROTEZ.SERR.P.F. SX S.100	PROTECTION SERR.P.F. GAUCHE S.100	LH OV.DOOR LOCK.SAFETY S.100	SCHUTZ, OF.TÜRSCHLOSS LINKS S.100
161169	CRISTALLO INT.P.F.SERIA 100	CRISTAL INT.P.F.SERIE 100	CRYSTALL GLASS, INS.FOR OV.SERIES 100	KRISTALLGLAS, INN.FÜR OF.REIHE 100
161172	CRISTALLO EST.P.F.SERIE 100	CRISTAL EXT.P.F.SERIE 100	CRYSTALL GLASS, OUT FOR OV.SERIES 100	KRISTALLGLAS, AUSS. FÜR OF.REIHE 100
161187	PERNO INF.CERN.VETRO P.FORNO	PIVOT INF.CHARN.VERRE PORTE FOUR	PIN, LOW.,GLASS HINGE FOR OVEN DOOR	ZAPFEN, UNTEN SCHARNIER FÜR OFENTÜR GLAS
161194	AS.COPERCHIO GAS DIRETTO	COUVERCLE EXT.	COVER EXT.	ABDECKUNG
161206	AS.COPERCHIO GAS	COUVERCLE EXT.	COVER EXT.	ABDECKUNG
161208	AS.COPERCHIO ELETTRICO	COUVERCLE EXT.	COVER EXT.	ABDECKUNG
161212	RAMPA SC.CONDENSE.INF.	RAMPE DU DÉCHARGEMENT CONDENSE	RAMP OUTLET COND.	DUNSTHAUBE
161257	DISTANZIALE GANCIO SER.P.FCV	CROCHET SERRURE	HOOK LOCK	HAKEN SCHLOSS
161273	AS.CERNIERA VETRO F.S.100/200	CHARNIERE VERRE F.S.100/200	HINGE, GLASS F.S.100/200	SCHARNIER, GLAS F.S.100/200
161274	GIRANTE VENT.10G	ROUE VENT.10G	IMPELLER, FAN 10G	LAUFRAD, LÜFTER 10G
161281	P/LAMPADA FCV 77737	PORTE-LAMPE FCV 77737	LAMP-HOLDER FCV 77737	LAMPENFASSUNG FCV 77737
<b>161282</b>	<b>LAMP.ALOG.FCV 20W 12VCC</b>	<b>LAMPE HALOGENE FCV 20W 12VCC</b>	<b>QUARTZ-IODINE LAMP FCV 20W 12VCC</b>	<b>HALOGENLAMPE FCV 20W 12VCC</b>
<b>161283</b>	<b>PROF.GUARNIZIONE CRUSC.FORNI</b>	<b>PROFIL JOINT PANN.FAÇ.FOURS</b>	<b>PROFILE, GASKET CONTROL PANEL OVENS</b>	<b>PROFIL, DICHTUNG OFENBEDIENTAFEL</b>
161384	SUP.CASS.FORNO FCV	SUPERIEUR CAISSON	UPPER PANEL	OBERERTAFEL
161387	CERN.INF.P.F.SX	CHARNIÈRE INFÉRIEUR GAUCHE PORTE DU FOUR	INGE PIN INFER.LEFT	MINDERWERTIGES SCHARNIER
161394	SUP.CRUSCOTTO FORNO SERIE 065	ÉGUERRE DE FIXAGE DU PANNEAU DE CONTRÔLE	BRACKET TO FIX THE CONTROL PANEL	STEUERTAFELBEFESTIGUNGSWINKEL
161395	SQ.FIS.PIEDINO FORNI S.060/100	ÉGUERRE DE FIXAGE DU PIED	BRACKET TO FIX THE FOOT	STEUERTAFELBEFEST FUSS
161397	PROTEZ.COMP.E.POST.AISI FEM109	PROTECTION THERMOSTAT FOUR	OVEN THERMOSTAT PROTECTION	THERMOSTATSCHUTZ
161401	SUP.BOYLER AISI FEM060	CHEMINÉE BOILER	CHIMNEY BOILER	KAMIN BOILER
161411	PROF.GUARN. CRUSCOTTO	JOINT	GASKET	DICHTUNG
161415	COPRILANA INF.FGMD107	PANNEAU COUVRE ISOLANT	INSULATING PANEL COVERING	ISOLIERMATERIALVERKLEIDUNG
161416	COPRILANA SX FEMD107	PANNEAU COUVRE ISOLANT GAUCHE	INSUL. PANEL COVERING	ISOLIERMATERIALVERKLEIDUNG
161417	COPRILANA INF.FEMD107/109	PANNEAU COUVRE ISOLANT	INSULATING PANEL COVERING	ISOLIERMATERIALVERKLEIDUNG
161418	COPRILANA POST.FEMD107	PANNEAU COUVRE ISOLANT POSTERIEUR	INSULATING PANEL COVER BACK	HINTERES COPRILANA
161419	COPRILANA POST.FGMD107	PANNEAU COUVRE ISOLANT POSTERIEUR	INSULATING PANEL COVER BACK	HINTERES COPRILANA
161426	COPRILANA DX FEMD107	PANNEAU COUVRE ISOLANT DROIT	INSULATING PANEL COVERING	ISOLIERMATERIALVERKLEIDUNG
161427	COPRILANA SUP.FEMD107	PANNEAU COUVRE ISOLANT SUPÉRIEUR	INSULATING PANEL COVER SUPERIOR	ISOLIERMATERIALVERKLEIDUNG
161432	COPRILANA SUP.FGMD107	PANNEAU COUVRE ISOLANT SUPÉRIEUR	INSULATING PANEL COVER	ISOLIERMATERIALVERKLEIDUNG
161477	GOMMINO PORTA FORNO	CAPSULE EN CAOUTCH. PORTE FOUR	RUBBER BUFFER, OVEN DOOR	GUMMIPUFFER, OFENTÜR

COD.	IT	FR	GB	DE
161508	TUBO GOMMA SC.COND.FCV.D.36X4,0 (MT.)	TUBE EN CAOUTCHAUC	RUBBER PIPE	ROHR GUMMI
161513	MOLLA GHIERA VETRO INT.P.FORNO	RESSORT BAGUE VERRE INT.PORTE FOUR	SPRING, INS.GLASS RING NUT OVEN DOOR	FEDER, GEWINDERING INN.GLAS OFENTÜR
161521	TU.AB.VAPORI FGM/FEM 107/110	TUYAU DÉTACHEMENT VAPEUR	PIPE STEAM	ROHR DAMPF
161553	NEBULIZZATORE FGC100	NÉBULISATEUR	DISTRIBUTOR	ZERSTÄUBER
161570	AS.PORTA F.DX SERIE 100	PORTE FOUR DROIT SERIE 100	DOOR, OVEN RH SERIES 100	TÜR, OFEN RECHT REIHE 100
161574	AS.CASSETTO DX S.060/100	BASSIN DROITE S.060/100	TRAY RIGHT S.060/100	SCHUBLADE RECHTS S.060/100
161581	AS.PROTEZ.SERR.P.F. DX S.100	PROTECTION SERR.P.F. DROIT S.100	RH OV.DOOR LOCK.SAFETY S.100	SCHUTZ, OF.TÜRSCHLOSS RECHT S.100
161682	VITE SX PER GIRANTE 10G 161274	VIS GAUCHE POUR ROUE 10G 161274	SCREW, LH FOR IMPELLER 10G 161274	SCHRAUBE, LINKS FÜR LAUFRAD 10G 161274
161683	VITE DX M6X55 TCEI INOX GIR.10G	VIS DROITE M6X55 TCEI INOX PIV.10G	SCREW RH M6X55 TCEI INOX, REV.10G	SCHRAUBE RECHTS M6X55 TCEI INOX, DREH.10G
162856	TU.UMIDIFICATORE INT.FEC100	HUMIDIFIER	HUMIDIFICATEUR	BEFEUCHTER
<b>164484</b>	<b>TERMOCOPPIA 6X100K</b>	<b>THERMOCOPPIA 6X100K</b>	<b>THERMOCOUPLE 6X100K</b>	<b>WAERMEPAAR 6X100K</b>
<b>164492</b>	<b>SCHEDA RELE</b>	<b>CARTE RELAIS FOUR ELECTRIQUE</b>	<b>RELAY BOARD</b>	<b>RELAISKARTE ELEKTRO-BACKOFEN</b>
164496	TU.AL.ACQ. D.10X16	TUBE DE CHARGEMENT DE L'EAU	PIPE WATERINLET	ROHR WASSERZUFLUSS
164498	TRASF.ROT.165VA+ROND.	TRANSF.165VA	TRANSF.165VA	TRANSF.165VA
164501	SONDA C/DIAM 4X100 K MBM00019	SONDE C/DIAM 4X100 K MBM00019	PROBE C/DIAM 4X100 K MBM00019	SONDE C/DIAM 4X100 K MBM00019
164502	CONNETTORE SONDA MBM00021	CONNECTEUR	CONNECTOR	VERBINDUNG
<b>164729</b>	<b>T/COPPIA 52 K MBM00017</b>	<b>THERMOCOUPLE 52 K MBM00017</b>	<b>THERMOCOUPLE 52 K MBM00017</b>	<b>THERMOELEMENT 52 K MBM00017</b>
164793	SCHEDA EL.COMANDI DGT.FEM110	FICHE EL.COMMANDES DGT.FEM110	CARD, EL.CONTROLS DGT.FEM110	PLATINE STEUER. DGT.FEM110
<b>164823</b>	<b>SCHEDA EL.</b>	<b>FICHE EL.</b>	<b>CARD, EL.</b>	<b>PLATINE</b>
<b>164825</b>	<b>SCHEDA EL.ENCODER F.FEM110</b>	<b>FICHE EL.ENCODER F.FEM110</b>	<b>CARD, EL.ENCODER F.FEM110</b>	<b>PLATINE ENCODER F.FEM110</b>
<b>164826</b>	<b>SCHEDA AL.</b>	<b>FICHE ALIMENT.</b>	<b>CARD, FEED.</b>	<b>KARTE, VERSORGUNG</b>
165056	MASCHER.CRUS.FEM610	MASQUE TABLEAU	COVER DASH BOARD	ABDECKUNGSTIRNBRETT
165074	POSTERIORE INOX	ARRIÈRE	POSTERIOUR	HINTEN
165077	MOTORE VENT.FGM110+COND.M80/4E/C1531	MOTEUR VENT.FGM110+COND.M80/4E/C1531	MOTOR, FAN FGM110+COND.M80/4E/C1531	MOTOR, LÜFTER FGM110+KOND.M80/4E/C1531
165111	ASSE ROTORE LAV.F.	ACHSE	WASHING DRIVE SHAFT	WASCHENDE ANTRIEBSACHSE
165115	BOCCOLA FIS.ASSE ROTORE LAV.F.	BUCHSE	BUSHING FIXING ROTOR	BUCHSEN-FESTLEGUNG-ROTOR
165116	MOLLA ROTORE LAV.	RESSORT ROTOR LAV.	SPRING, WASH.ROTOR	FEDER, SPÜL.ROTOR
165281	UGELLO LAVAGGIO D1.5	INJECTEUR LAVAGE D1.5	INJECTOR, WASH. D1.5	EINSPRITZER, SPÜL. D1.5
165285	TU.PESC.DET.LAV.D.4X6	TUYAU	DETERGENT TUBE	ROHR
<b>165348</b>	<b>DISTANZ.FRONT.SCH.EL.</b>	<b>ENTRTOISE</b>	<b>SPACER</b>	<b>DISTANZSTÜCK</b>
165597	FILTRO DI FONDO LAV.FORNO 9900106162	FILTRE	FILTER	FILTER
165660	IS.EST.BOYLER FEM110	PROFIL ISOLANT	INSULATING BAND	ISOLIERPROFIL
165663	IS.INT.BOYLER FEM110	PROFIL ISOLANT	INSULATING BAND	ISOLIERPROFIL
165665	EROGATORE ACQ.LAV.INT.F.FGM610	DISTRIBUTEUR EAU LAV.INT.F.FGM610	WATER DISPENSER OV.INS.WASH FGM610	WASSERSPENDER INN.SPÜL. FGM610
166012	SUPPORTO	SUPPORT	SUPPORT	HALTERUNG

COD.	IT	FR	GB	DE
167012	SQUADRETTA FISSAGGIO INNESTO RAPIDO	EQUERRE	PLATE	AUFSPANNWINKEL
167137	RACCORDO IN OTTONE	RACCORD	PIPE	FITTING
167481	TUBO SCARICO ACQUA BOILER GAS	TUBE DE DECHARGE DE L'EAU	WATER DISCHARGE PIPE	WASSERABLASSROHR
167483	TUBO SCARICO ACQUA BOILER ELETT	TUBE DE DECHARGE DE L'EAU	WATER DISCHARGE PIPE	WASSERABLASSROHR
167563	AS. CASSETTO SX INT. P.F.100	GROUPE BASSIN GAUCHE	UNIT DRAWER LEFT	ZUSAMMEN FACH
167631	AS.CASSETTO DX INT.PORTA F.FGMD107	INTERNE BASSIN DROITE F.FGMD107	INTERNAL TRAY RIGHT F.FGMD107	INTERNE SCHUBLADE RECHTS F.FGMD107
167696	SQ.SUP.TUBO AB.VAPORI FGM6/10	EGUERRE TUYAU DÉTACHEMENT VAPEUR	PIPE STEAM SUPPORT	ROHR DAMPF HALTERUNG
167728	SUP.MICRO PORTA FORNO 6-10G.	SUPPORT MICRO	BRACKET MICRO	UNTERSETZUNGSGETRIEBE
<b>167956</b>	<b>OR E50I7/E100I NBR 56,52X5,34 550601031</b>	<b>O-RING</b>	<b>O-RING</b>	<b>O-RING</b>
168119	SCHEDA EL. BIANCA (NO LAVAGGIO)	CARTE DE COMMANDE	ELECTRIC SCHEME	SCHALTPLAN
169254	GUARNIZ.DI RACC.TUBO ALIM.BRUC.	GARNITURE	GASKET	DICHTUNG
<b>169462</b>	<b>SCHEDA CPU 256K</b>	<b>SCHEDA</b>	<b>SCHEME</b>	<b>SCHALTPLAN</b>
170162	SUP.GRUPPO SCHEDA EL.	SUPPORT GROUPE CARTE	SUPPORT DISPLAY BOARD	TRÄGER KARTENGRUPPE
170247	PROTEZIONE GRUPPO IMPIANTI NEW	PROTECTION	PROTECTION	SCHUTZ
170522	MANOP.COND.FCV.NERA SWEET 242211-C1	BOUTON	KNOB	DREHGRIFF
170527	AS.CRUSCOTTO	PANNEAU DE CONTRÔLE	CONTROL PANEL	STIRNBRETT
<b>170831</b>	<b>BASETTA MANIGLIA F.MBM ZAMA CR.FINITA</b>	<b>EPAISSEUR POIGNÉE</b>	<b>HANDLE</b>	<b>HANDGRIFF</b>
<b>170919</b>	<b>MANIGLIA F.FCV/2 MBM NEW - RAL7031/20</b>	<b>POIGNÉE</b>	<b>HANDLE</b>	<b>HANDGRIFF</b>
170955	MANOP.COM.F.SERIE DRIVE	POIGNEE COMMUT.F.SERIE DRIVE	KNOB, COMM.F.SERIES DRIVE	DREHKNOPF, UMSCH.F.REIHE DRIVE
171945	GRIGLIA LAT.FCVM/10G INOX *NEW*	GRILLE LATÉRALE DU FOUR	OVEN LATERAL GRATE	OFENROST
172048	PERNO FINEC.P/TEGLIE LAT.10GN F.MBM	DOVILLE DE BUTÉE	LOCK BUSHING	FESTSTELLBUCHSE
172224	CONV.ARIA FEC100	CONVOYEUR AIR	AIR CONVEYOR	LUFTFÖRDERER
172231	CONV.ARIA FGC100	CONVOYEUR AIR	AIR CONVEYOR	LUFTFÖRDERER
172233	LAM.FISSA CONV.ARIA FGM110L	FIXE FICHE DE CONVOYEUR AIR	FIXED SHEET FOR AIR CONVEYOR	FESTEN BLATT FUR LUFTFORDERER
172646	GR.IMP.+C.FGMD610/FGMD110 2008	GROUPE CARTE	DISPLAY BOARD	KARTENGRUPPE
172648	GR.IMP.+C.FEMD610/FEMD110 2008	GROUPE CARTE	DISPLAY BOARD	KARTENGRUPPE
172651	GR.IMP.+C.FGM110 2008	GROUPE CARTE	DISPLAY BOARD	KARTENGRUPPE
172653	GR.IMP.+C.FEM110 2008	GROUPE CARTE	DISPLAY BOARD	KARTENGRUPPE
172655	POMPA LAVAGGIO	RESERVOIR LAVAGE	DETERGENT PUMP	SPÜLTANK
172657	CAB.IDRAULICO POMPA LAV.	CABLAGE	IDRAULIC WIRING HARNESS	VERKABELUNG
172687	MAGNETOTERMICO 230V	INTERRUPTEUR MAGNETIQUE	SWITCH	SCHALTER
<b>173195</b>	<b>RONDELLA OTTONE</b>	<b>RONDELLE</b>	<b>WASHER</b>	<b>SCHEIBE</b>
173449	TU.AL.BRUC.BOYLER FGM100	TUYAU D'ALIMENTATION DU BRÛLEUR	BURNER CHAMBER PIPE	ROHR KAMMER
173961	CALOTTA ROTORE LAVAGGIO	CALOTTE ROTOR LAV.	ROTOR COVER	ROTORKALOTTE
173963	ASS. ROTATIVO LAVAGGIO	MOYEU FIXATION BRAS	SUPPORT WASHING DRIVE	ARME-BEFESTIGUNGSNABE



COD.	IT	FR	GB	DE
173964	RONDELLA SPECIALE	RONDELLE	WASHER	SCHEIBE
175075	REGOLATORE LUNGO LIV.BOY.	RÉGULATEUR	REGULATOR	REGLER
175125	FLANGIA P/TENUTA TUBO DI.136	DRAINAGE SORTI DE BRIDE	EXITED FLANGE DRAINAGE	HERAUSGENOMMENE FLANSCH-ENTWÄSSERUNG
175127	FLANGIA P/TENUTA TUBO DI.58,5	DRAINAGE SORTI DE BRIDE	EXITED FLANGE DRAINAGE	HERAUSGENOMMENE FLANSCH-ENTWÄSSERUNG
175128	FLANGIA P/TENUTA TUBO DI.44	DRAINAGE SORTI DE BRIDE	EXITED FLANGE DRAINAGE	HERAUSGENOMMENE FLANSCH-ENTWÄSSERUNG
175131	BOYLER E.FGM110	BOILER	BOILER	BOILER
175135	BOYLER E.FEM110	BOILER	BOILER	BOILER
175138	FLANGIA P/TENUTA TUBO DI.166	DRAINAGE SORTI DE BRIDE	EXITED FLANGE DRAINAGE	HERAUSGENOMMENE FLANSCH-ENTWÄSSERUNG
175268	ATTACCO PER TUBO RILSAN 1511 8X1/8"	TUYAU DE COUPLAGE	CONNECTOR 8x1/8" RILSAN PIPE	SCHLAUCHGELENKE
175350	VALVOLA NON RITORNO F 1/4"-1/4"	VALVOLA	VALVE	VENTIL
175352	ATTACCO PER TUBO RILSAN 6510 8X1/4"	TUYAU DE COUPLAGE	CONNECTOR 8x1/4" RILSAN PIPE	SCHLAUCHGELENKE
175393	TUBO TEFLON TUBO 8X6 PTFE VERG.	TUYAU	TEFLON PIPE 8x6 PTFE COLOURLESS	TEFLONSCHLAUCH
175489	FERRITE PER FLAT CABLE	FERRITE	FERRITE	FERRIT
175659	FERRITE PER SONDA	FERRITE	FERRITE	FERRIT
175744	FILTRO EPCOS	FILTRE	FILTER	FILTER
175780	CENTRALINA ACC. FORNI	UNITÉ DE CONTRÔLE	CONTROL UNIT	ELEKTRONISCHE STEUERINHEIT
<b>175781</b>	<b>CAB.CORPO VALV.F.GAS</b>	<b>CÂBLE</b>	<b>CABLE</b>	<b>KABEL</b>
178189	SQ.FIS.CANDELETTE FORNI GAS	EGUERRE DE FIXAGE	BRACKET TO FIX	BEFESTIGUNGSWINKEL
178257	E/VALV.LAVAGGIO	SOL.VALVE	ELECTROV.	E/VENTIL
178262	RACC.DIR.3/4"F. + INN.RAP.TUBO Ø8	RACCORD	PIPE	FITTING
178263	INIET.UMIDIF.FCV D.1.5	INJECT., HUM.FCV D.1.5	INJECT.HUMIDIF.FCV D.1.5	EINSPR., BEFEUCHT.FCV D.1.5
178265	MOTORID. P34 1 CAMMA 230 VAC 1G/1+GIUN.	MOTOREDUCTEUR	GEARMOTOR	GETRIEBEMOTOR
178266	SUP.MOTORID.SCA.COND.FEM110	SUPPORT MOTOREDUCTEUR	BRACKET GEARMOTOR	UNTERSETZUNGSGETRIEBE
178272	TU.AL.ACQ.BOYLER FGM110	TUBE DE CHARGEMENT DE L'EAU	PIPE WATERINLET	ROHR WASSERZUFLUSS
178273	TU.AL.LAVAGGIO POST. FGM/FEM110L	TUYAU POST. LAVAGE FGM/FEM110L	HOSE, BACK WASHING FGM/FEM110L	SCHLAUCH FGM/FEM110L
178274	TU.AL.ACQUA UMIDIFIC. FGM110	HUMIDIFIER FGM110	HUMIDIFICATEUR FGM110	BEFEUCHTER FGM110
178275	TU.AL.ROTORE LAV.F.FEM/FGM110L	TUYAU REF.ROTOR LAV.F.FEM/FGM110L	PIPE, ROTOR FEED. WASH. F.FEM/FGM110L	ZULEITUNGSROHR, ROTOR SPÜL. F.FEM/FGM110L
178277	TU.AL.ACQUA UMIDIFIC. FEM110	HUMIDIFIER FEM110	HUMIDIFICATEUR FEM110	BEFEUCHTER FEM110
178284	LAM.PARASPRUZZI RESISTENZE FEM110	TÔLE DE PROTECTION	PROTECTIVE PLATE	SCHUTZBLECH
178318	AS.BASAM. F.SERIE 060/100	ENSEMBLE BASE	TOGETHER BASE	ZUSAMMEN UNTERSEITE
178319	RAMPA SCARICO CONDENSA SUP.	PANNEAU ISOLANT	INSULATING PANEL	ISOLIERENDE VERKLEIDUNG
178324	AS.COPERCHIO FEM110/107 -CE-	COUVERCLE EXT.	COVER EXT.	ABDECKUNG
178325	FIANCO DX FEM110/107 -CE-	CÔTÉ DROITE	SIDEPANEL RIGHT	SEITENTEIL RECHTS
178326	POSTERIORE INOX FEM110/107 -CE-	ARRIÈRE	POSTERIOUR	HINTEN
178328	AS.COPERCHIO FEMD110/107 -CE-	COUVERCLE EXT.	COVER EXT.	ABDECKUNG

COD.	IT	FR	GB	DE
178330	COPERTURA FILTRO	PROTECTION	PROTECTION	SCHUTZ
178335	SQUADR.FISS.ELETTROV.LAV.	EQUERRE	PLATE	AUFSPANNWINKEL
178336	ALBERO MOTORID.VALV.FARFALLA	ARBRE	SHAFT	WELLE
178339	PARATIA VENTILAZIONE	PROTECTION	PROTECTION	SCHUTZ
178379	TU.AL.ACQ.BOYLER FEM110	TUBE DE CHARGEMENT DE L'EAU	PIPE WATERINLET	ROHR WASSERZUFLUSS
178445	GRIGLIA PROT.SPACCO BRUC.FEM110	GRILLE DE PROTECTION	SHIELD GRID	SCHUTZGITTER
178446	GRIGLIA PROT.SPACCO DOCCIA FEM110	GRILLE DE PROTECTION	SHIELD GRID	SCHUTZGITTER
178923	ASTA TRAS.SCA.COND.FEM110	BARRE TRANS.VID.EAU DE COND.FEM110	ROD, COND.DRAIN FEM110	STAB, KOND.ABL. FEM110
178943	AS.BLOCCO PORTA SX	PORTE BLOC	DOOR BLOCK	TÜR BLOCK
178944	DIST.CERN.SUP.RETROFIT BLOCCO PORTA	ENTRETOISE	SPACER, HINGE - OVEN	ABSTANDSSTÜCK
178947	PIASTRA INF.BLOCCO ROTAZ.P.SX	PLAQUE	PLATE	PLATE
GAFOC00027	AS.C/FORO CASS.FCV/1	C/TROU TIROIR FCV/1	DRAWER HOLES FCV/1	LÖCHER, SCHUBFACH FCV/1
GAFOC00030	AS.CERN.SUP.SX P.F.FCV.	CHARNIERE SUP.GAUCHE P.F.FCV.	HINGE, UPPER LH	SCHARNIER, OBEN LINKS
<b>GAFOC00051</b>	<b>AS. SERRATURA P.F.</b>	<b>ENSEMBLE VERROUILLAGE P.F.</b>	<b>LOCKING MECHANISM</b>	<b>GRUPPE OFENTÜRSCHLOSS</b>
GAFOC00072	AS.CAMERA COMB.FGC100	CHAMBRE COMB.FGC100	COMB.CHAMB. FGC100	BRENNKAMM. FGC100
GAFOC00073	AS.BRUC.FGC100	BRÛL.FGC100	BURNER FGC100	BRENNER FGC100
GAFOC00108	AS.BRUC.BOY FGM	BRÛLEUR	BURNER	BRENNER
GAFOC00115	AS.CAMERA COMB.BOYLER FGM100	COMBUSTION CHAMBER	CHAMBRE DE COMBUSTION	BRENNKAMMER
GAFOC00116	AS.CAMINO BOYLER FGM101	CHEMINÉE BOILER	CHIMNEY BOILER	KAMIN BOILER
GAFOC00118	AS.CONV.CALORE FEM109	CONVOYER CHALEUR	HEAT CONVEYOR	WARMEVENTILATOR
GAFOC00188	AS.SUP.VENT.FEC100 ZINC.	VENT.FEC100 GALV.	SUPPORT, FAN FEC100 GALV.	HALTERUNG, GEBL. FEC100 VERZ.
GAFOC00189	AS.CAMINO INT.FGC100	ENSEMBLE CHEMINÉE	TOGETHER FIREPLACE	ZUSAMMEN KAMIN
GAFOC00190	AS.CAMINO INT.FGC100 DIRETTO	ENSEMBLE CHEMINÉE	TOGETHER FIREPLACE	ZUSAMMEN KAMIN
GAFOC00213	AS.CERN.SUP.DX P.F.FCV	CHARNIERE SUP.DROIT P.F.FCV.	HINGE, UPPER RH	SCHARNIER, OBEN RECHT
MPGOM03P00	TUBO GOMMA Ø 10X17 10ATM	LE CAOUTCHOUC DE TUBE	TUBE RUBBER	SCHLAUCH-GUMMI
PAFOC00103	SQ.FIS.BRUC.FGC060	ÉGUERRE FIXAGE BRÛLEUR	BRACKET TO FIX BURNER	BRENNERHALTEWINKEL
PAFOC00122	DEVIATORE FUMI FGC100	FUMÉE DE DÉRIVATEUR	SHUNTER SMOKE	RANGIERER-RAUCH
PAFOC00211	SQ. REGOL. VALVOLA PESO	SUPPORTE DE LA VALVE GAS	VALVE UNIT SUPPORT	GASVENTILHALTERUNG
PAFOC00222	SQ.FIS.BRUC.BOYLER FGM061	ÉGUERRE FIXAGE BRÛLEUR	BRACKET TO FIX BURNER	BRENNERHALTEWINKEL
PAFOC00234	PROTEZ.CONV.CALORE FEM109	LA CHALEUR DE PROTECTION	PROTECTION HEAT	SCHUTZ-HITZE
PAFOC00245	COPERCHIO CAM.COMB.FGC100	COUVERCLE	COVER	BECKENABDECKUNG
PAFOC00247	COPERCHIO ISP.CAND.BOY.FGM109	COUVERCLE	COVER	TOPFDECKEL
<b>PAFOC00249</b>	<b>CAND.RIL.BRU.FGM</b>	<b>BOUGIE D'ALLUM. DECL.BRÛL.FGM</b>	<b>SPARK PLUG, REL.BURN.FGM</b>	<b>KERZE, BRENN.FREIG.FGM</b>
<b>PAFOC00250</b>	<b>CAND.RIL.BRU.B.FGM109/95 15405</b>	<b>ELECTRODE DÉTECTION</b>	<b>SPARK PLUG DI RILEVAZ.</b>	<b>ZÜNDKERZE</b>
<b>PAFOC00251</b>	<b>CAND.ACC.BRU.B.FGM</b>	<b>BOUGIE D'ALLUMAGE BRÛL.B.FGM</b>	<b>SPARK PLUG, BURN.B.FGM</b>	<b>ZÜNDKERZE, BRENN.B.FGM</b>

COD.	IT	FR	GB	DE
<b>PAFOC00252</b>	<b>CAND.ACC.BRU.F.FGM</b>	<b>BOUGIE D'ALLUMAGE BRÛL.F.FGM</b>	<b>SPARK PLUG, BURN.F.FGM</b>	<b>ZÜNDKERZE, BRENN.F.FGM</b>
PAFOC00329	DISCO SCARICO COND.FEC200	DISQUE VIDANGE EAU DE COND.FEC200	DISC, COND. DRAIN FEC200	SCHEIBE, KOND.ABLASS FEC200
PAFOC00422	COPERCHIO ISP.CAMINO FGC100	CHEMINÉE DE COUVERTURE	COVER FIREPLACE	ABDECKUNGS-KAMIN
PAFOC00455	PROTEZ.BULBO TERM.FEMD065	EGUERRE DE FIXAGE	BRACKET TO FIX BULB	BEFESTIGUNGSWINKEL
PAFOC00494	TRA.A/GOCCIA SX FACC.FEC060/1	ENSEMBLE TIROIR INF.R/GOUTTE P.F.	CAVITY DRIP TRAY	GRUPPE UNTERES FACH
PAFOC00542	FIANCO DX FEC100	CÔTÉ DROITE	SIDEPANEL RIGHT	SEITENTEIL RECHTS
PAFOC00543	FIANCO SX FEC100	CÔTÉ GAUCHE	SIDEPANEL LEFT	SEITENTEIL LINKES
PAFOC00544	SUP.BOYLER FGM060/1	CHEMINÉE BOILER	CHIMNEY BOILER	KAMIN BOILER
PAFOC00552	PROTEZ.TU.SCAMBIATORE FGC100/1	ECHANGEUR DE PROTECTION	EXCHANGER PROTECTION	EXCHANGER SCHUTZ
PAFOC00554	DEFLETTORE BRUC.FGC100/1	CHICANE BURNER	BAFFLE PLATE	HINTERES STAUBLECH
PAFOC00562	SUP.MICRO SCA COND	SUPPORT MICRO	BRACKET MICRO	UNTERSETZUNGSGETRIEBE
PAFOC00565	FLANGIA FIS.TU.PROT.SCAMB.FCV2	BRIDE	FLANGE	FLANSCH
PAFOC00583	CERN.INF.P.F.DX FCV	CHARNIÈRE INFÉRIEUR DROIT PORTE DU FOUR	INGE PIN INFER.RIGHT	SCHARNIER UNTEN RECHT
PAFOC00680	DISCO INF.SCARICO COND.FEMD100	DISQUE INF.VIDANGE EAU DE COND.FEMD100	DISC, INF.SCARICO COND.FEMD100	SCHEIBE, UNT. KOND.ABLASS FEMD100
PAFOC00726	SQ.FIS.PAN.IS.CAM.INT.FCG6	EQ.FIX.PANNEAU IS.CHEMINEE INT.FCG6	BRACK., FIX.PAN.INS.CHIMNEY FCG6	BEF.WINKEL, ISOL.PLATTE INN.SCHORNSTEIN FCG6
<b>RIC0003591</b>	<b>RELAIS ST.MOT.25A 24-520VAC-SC76211031</b>	<b>RELAIS ST.MOT.25A 24-520VAC-SC</b>	<b>RELAY, ST.MOT.25A 24-520VAC-SC</b>	<b>*STATISCHES RELAIS, MOT.25A 24-520VAC-SC76211031</b>
<b>RIC0003593</b>	<b>RELE' STATICO 75A 400VAC</b>	<b>RELAIS</b>	<b>RELAY</b>	<b>RELAIS</b>
RIC0003594	MORSETTIERA	CONNECTION DES CABLES	TERMINAL BOARD	KLEMMBRETT
RIC0003595	MORSETTIERA	CONNECTION DES CABLES	TERMINAL BOARD	KLEMMBRETT
RIC0003609	FUSIBILE 10A RITARD. DRIVE T10AHPC	*FUSIBLE 10A RETARD. DRIVE T10AHPC	FUSE, 10A DELAY. DRIVE T10AHPC	*SICHERUNG, 10A TRÄGE, DRIVE T10AHPC
<b>RIC0003962</b>	<b>ELETTROVALVOLA</b>	<b>SOUPAPE</b>	<b>ELECTRIC VALVE</b>	<b>ELEKTROVENTIL</b>
RIC0004244	RAC.IDR. JG 8/10	RACCORD	PIPE COUPLING	FITTING
RIC0004245	RAC.IDR.GRIGIO 3/4BSP JG8+M20	RACCORD	PIPE COUPLING	FITTING
RIC0004308	SCHEDA EL. RELAIS F. GAS	CARTE RELAIS	SCHEME RELAY	SCHALTPLAN RELAIS
<b>RTBF800015</b>	<b>CALOTTA D.14 ART.181 GBR</b>	<b>ECROU LAITON D.14</b>	<b>NUT, Br.D.14</b>	<b>MUTTER, MESS. D.14</b>
<b>RTBF800137</b>	<b>BICONO D.14 ART.182 GBR</b>	<b>BICÔNE D.14</b>	<b>BICONE, D.14</b>	<b>ZWEIKEGEL D.14</b>
RTBF800138	F/CAVO PG21 53015050+D53019050C	ARRÊT DU CABLE	CHOCK	KABELDURCHGANG
RTBF800139	F/CAVO PG13	ARRÊT DU CABLE	CHOCK	KABELDURCHGANG
RTCP800012	SUPPORTO INIET.1/2"BRUC.GBR	SUPPORT INJECTEUR	SUPPORT INJECTOR	HALTERUNG EINSPRITZER
RTCP800013	DADO 1/2"ES.27X7 OT.UNI5589	ECROU 1/2"ES.27X7 OT.UNI5589	NUT 1/2"ES.27X7 OT.UNI5589	MUTTER 1/2"ES.27X7 OT.UNI5589
RTCP800118	TU.FLES+G.AL.RUB.VAP.MF3/4"245 008580	TUYAU	PIPE FLEXIBLE	ROHR FLEXIBEL
RTCP900087	NIPLES CP OT/M/1/2"XM20/D.14	NIPLES CP OT/M/1/2"XM20/D.14	NIPPLE CP OT/M/1/2"XM20/D.14	NIPPEL CP MESS./M/1/2"XM20/D.14
RTCP900088	BICONO D.14 CP	BICÔNE D.14 CP	BICONE, D.14 CP	ZWEIKEGEL D.14 CP
RTCP900089	CALOTTA OT.D.14 CP	ECROU LAITON D.14 CP	NUT, Br.D.14 CP+J7388	MUTTER, MESS. D.14 CP
RTCU900012	BICONO D.10	BICONE Ø10	BICONE, D.10	ZWEIKEGEL D.10

COD.	IT	FR	GB	DE
RTCU900013	CALOTTA D.10	ECROU LAITON D.10	NUT, Br.D.10	MUTTER, MESS. D.10
RTCU900018	BICONO D.6 PEL0905	BICONE Ø6	BICONE Ø6	ZWEIKEGEL Ø6
RTFOC00005	ZOCCOLO EST.SER.P.FCV.020945	SOCLE EXT.SERR.P. FCV.020945	SOCLE, OUT. PLINTH FCV.020945	SOCKEL, AUSS. SER.P.FCV.020945
RTFOC00009	GANCIO FISSO SER.P.FCV.010218	CROCHET FIXE SERRURE PORTE FCV.010218	HOOK, FIX, OVEN DOOR LOCK 010218	HAKEN, FEST OFENTÜRVERRIEG. 010218
RTFOC00020	CALOTTA UMIDIF.FCV.	ECROU	NUT	MUTTER
<b>RTFOC00035</b>	<b>MICROINT.FCV.NR 6K5</b>	<b>MINIRUPT.FCV.NR 6K5</b>	<b>MICROSWITCH NR 6K5</b>	<b>MIKROSCHALTER FCV.NR 6K5</b>
RTFOC00057	ZOCCOLO CENT.SER.P.FCV.020944	SOCLE, CENTR.PLINTH FCV.020944	SOCLE CENTR.SERR.P.FCV.020944	SOCKEL, ZENTR.SER.P.FCV.020944
<b>RTFOC00068</b>	<b>R.FEC100 2,5KW240 1GIK2.R853.002</b>	<b>RESISTANCE 2,5KW240</b>	<b>RESISTANCE 2,5KW240</b>	<b>WIDERSTAND 2,5KW240</b>
RTFOC00100	GUARNIZ.AS.RAMPA FGC060	JOINT TUYAU PRINCIPAL FGC060	GASKET, MAIN PIPE FGC060	DICHTUNG, RAMPE FGC060
RTFOC00126	TUBO FLESSIBILE	TUYAU	FLEXIBLE PIPE	ROHR
<b>RTFOC00173</b>	<b>T.L.FEM061 Tø120 5510522835</b>	<b>THERMOSTAT LIMITATEUR.</b>	<b>THERMOSTAT LIMIT.</b>	<b>TERMOSTAT</b>
RTFOC00174	GRIGLIA PROT.VENT.FCV10G.INOX	GRILLE PROT.VENT.FCV10G.INOX	GRID, OVEN PROT.10G.INOX	ROST, GEBL.SCHUTZ FCV10G.INOX
RTFOC00175	GRIGLIA F.FCV.1/1 INOX	GRILLE F.FCV.1/1 INOX	GRID, OVEN 1/1 INOX	ROST, OFEN 1/1 INOX
RTFOC00186	DADO 3/4"	ECROU3/4"	NUT 3/4"	MUTTER 3/4"
RTFOC00201	VETRO P/LAMPADA FCV.	VERRE PORTE-LAMPE FCV.	GLASS, LAMP-HOLDER FCV.	GLAS, LAMPENFASSUNG FCV.
RTFOC00212	VALVOLA PESO	VALVE	VALVE	VENTIL
RTFOC00213	GUARNIZIONE VALVOLA PESO	GARNITURE	GASKET	DICHTUNG
RTFOC00214	ASTA ATTACCO VALVOLA PESO	BARRE VALVE	ROD VALVE	STAB VENTIL
RTFOC00216	TU.FLES.PRES.BIANCO/75 0106300	TUYAU	PIPE FLEXIBLE	ROHR FLEXIBEL
<b>RTFOC00231</b>	<b>T.L.FGM101 Tø300 5519552040</b>	<b>THERMOSTAT LIMITATEUR.</b>	<b>THERMOSTAT LIMIT.</b>	<b>TERMOSTAT</b>
<b>RTFOC00254</b>	<b>VENT.CALORE FEM109</b>	<b>VENT.CHALEUR FEM109</b>	<b>FAN, HEAT. FEM109</b>	<b>LÜFTER, WÄRME FEM109</b>
RTFOC00256	CONDENSATORE FCVEM CRU26231943 0,12 MF	CONDENSATEUR FCVEM CRU26231943 0,12 MF	CONDENSER FCVEM CRU26231943 0,12 MF	KONDENSATOR FCVEM CRU26231943 0,12 MF
RTFOC00301	ANELLO TENUTA ALB.MOT.FGC060	BAGUE D'ETANCHEITE ARBRE MOT.FGC060	RING, SEAL FOR DRIV.SHAFT FGC060	DICHTUNGSRING, ANTRIEBSWELLE FGC060
RTFOC00334	AT.RAPIDO K1610/TA16/C16X	FIX.RAPIDE K1610/TA16/C16X	CONN., FAST K1610/TA16/C16X	SCHNELLEBESFESTIGUNG K1610/TA16/C16X
<b>RTFOC00337</b>	<b>ANELLO INT.GRADINO MAN.P.F.FCV</b>	<b>BAGUE INT.POUR POIGNEE PORTE FOUR FCV</b>	<b>RING, INS. FOR KNOB</b>	<b>RING, INN. FÜR DREHKNOPF</b>
<b>RTFOC00338</b>	<b>ANELLO EST.MAN.P.F.FCV.</b>	<b>BAGUE EXT.POIGNEE PORTE FOUR FCV.</b>	<b>RING, OUT.ADHESIVE FOR KNOB FCV.</b>	<b>RING, AUSS. DREHKNOPF FCV.</b>
RTFOC00350	RAMPA GAS	RAMPE DU GAZ	RAMP GAS	RAMPE GAS
RTFOC00382	CORNICE FIS.VETRO P/LAMP.FCV	CADRE FIX.VERRE PORTE-LAMPE FCV	FRAME, OV. LAMPHOLDER GLASS FCV	RAHMEN, BEF. GLAS LAMPENFASS. FCV
RTFOC00413	PIEDINO+T.FGC100	PIED	FOOT	FUSS
RTFOC00444	PANNELLO IS.ANT.BOYLER FCVM	PANNEAU ISOLANT	INSULATING PANEL	ISOLIERTAFEL
RTFOC00445	PANNELLO IS.SX BOYLER FCVM	PANNEAU ISOLANT	INSULATING PANEL	ISOLIERTAFEL
RTFOC00446	PANNELLO IS.POST.BOYLER FCVM	PANNEAU ISOLANT POSTERIEUR	BACK INSULATING PANEL	HINTERE ISOLIERTAFEL
RTFOC00447	PANNELLO IS.DX BOYLER FCVM	PANNEAU ISOLANT	INSULATING PANEL	ISOLIERTAFEL
RTFOC00481	PANNELLO IS.INF.FCE10	PANNEAU INFÉRIEUR	LOWER PANEL	UNTERE TAFEL
RTFOC00482	PANNELLO IS.SUP.FCE20	PANNEAU ISOLANT SUPERIEUR	UPPER INSULATING PANEL	OBERE ISOLIERTAFEL

COD.	IT	FR	GB	DE
<b>RTFOC00483</b>	<b>T.L.FCV/1T350 5510562800</b>	<b>THERMOSTAT LIMIT SW. FCV/1T350 5510562800</b>	<b>THERMOST.LIM.FCV/1T350 5510562800</b>	<b>ENDSCHALTER, THERMOSTAT FCV/1T350 5510562800</b>
RTFOC00488	PANNELLO IS.INF.FCG10	PANNEAU INFÉRIEUR	LOWER PANEL	UNTERE TAFEL
RTFOC00489	PANNELLO IS.SUP.FCG10	PANNEAU ISOLANT SUPERIEUR CAISSON	BODY INSULATING UPPER PANEL	OBERE ISOLIERTAFEL
RTFOC00492	TU.UMIDIFICATORE EST.FEC100	TUYAU HUMIDIFICATEUR EXT.FEC100	PIPE, HUMID., OUTS.FEC100	ROHR, BEFEUCHT., AUSS.FEC100
RTFOC00509	F/CAVO FGC060/1 PA107	CHAUMARD	CHOCK	KABELDURCHGANG
RTFOC00512	PANNELLO IS.DX-SX 100	PANNEAU ISOLANT	INSULATING PANEL	ISOLIERTAFEL
RTFOC00513	PANNELLO IS.POST.100	PANNEAU ISOLANT POSTÉRIEUR	BACK INSULATING PANEL	ISOLIERTAFEL
RTFOC00514	DISTANZ.INF/SUP SERR	ENTRETOISE .SERRURE FGC060/1	SPACER, LOCK.GC060/1	ABSTANDSSTÜCK, .VERRIEG.GC060/1
RTFOC00515	DISTANZ.CENT.SERR.FGC060/1	ENTRETOISE CENTR.SERRURE FGC060/1	SPACER, CENTR.LOCK.GC060/1	ABSTANDSSTÜCK, ZENTR.VERRIEG.GC060/1
RTFOC00516	TU.PROTEZ.SCAMB.FGC100/1	PROTECTION DE TUBE	TUBE PROTECTION	SCHLAUCH-SCHUTZ
<b>RTFOC00523</b>	<b>R.BOY.FEM.6KW230 1GEL7D201006</b>	<b>RESISTANCE 6KW230</b>	<b>RESISTANCE 6KW230</b>	<b>WIEDERSTAND 6KW230</b>
<b>RTFOC00577</b>	<b>CORPO V.FGM</b>	<b>CORPS SOUP.FGM</b>	<b>VALVE HOUS. HOUS., FGM</b>	<b>VENTILGEH. FGM</b>
<b>RTFOC00624</b>	<b>REGOLATORE PRES.FGMD MW5208001</b>	<b>REGULATEUR PRESSION</b>	<b>PRESSURE REGULATOR</b>	<b>DRUCKREGLER</b>
RTFOC00625	MANOMETRO FGMD WI8921180	MANOMÈTRE	MANOMETER	SICHERHEITSVENTIL
RTFOC00693	TU.AL.BRUC.FGC100	TUYAU D'ALIMENTATION DU BRÛLEUR	BURNER CHAMBER PIPE	ROHR KAMMER
<b>RTFOC00722</b>	<b>GUARNIZIONE PORTA</b>	<b>GUARNITUR POUR PORTE</b>	<b>DOOR GASKET</b>	<b>TÜRDICHTUNG</b>
RTFOC00761	PANNELLO IS.COP.ISPEZ.FGMD107	PANNEAU ISOLANT	INSULATING PANEL	ISOLIERTAFEL
RTFOC00769	PANNELLO IS.ANT.CAM.INT.FCG10	PANNEAU ISOLANT AVANT	FRONT INSULATING PANEL	VORDERE ISOLIERENDE VERKLEIDUNG
RTFOC00772	PANNELLO IS.SUP.CAM.INT.FCG10	PANNEAU ISOLANT AVANCÉ	ADVANCED INSULATING PANEL	VORGERÜCKTE ISOLIERENDE VERKLEIDUNG
RTMIN00114	DADO M6ES.CIECO INOX	ECROU M6ES.BORGNE INOX	NUT, M6ES.CAP NUT INOX	HUTMUTTER, M6ES. INOX

**RICAMBI CONSIGLIATI**

**= PIÈCES DE RECHANGE RECOMMANDÉES**

**= RECOMMENDED SPARE PARTS**

**= EMPFOHLENE ERSATZTEILE**