

NME950 & FME1200 SERVICE PARTS

This parts list contains the service parts and wiring diagrams for this model. Check the model number in question to be sure that it is applicable to this parts list.

Note that these machines have been manufactured in both 50 and 60 cycle.
60 Hz model numbers end in -3 or -32.
50 Hz model numbers end in -6.

TABLE OF CONTENTS

Cabinet	2
Air Cooled Refrigeration	3
Water Cooled Refrigeration.....	4
Water System	5
Gearmotor.....	6
NME Evaporator	7
FME Evaporator	8
Control Box.....	9
Wiring Diagrams.....	10

NME950 & FME1200 SERVICE PARTS

Cabinet Assembly

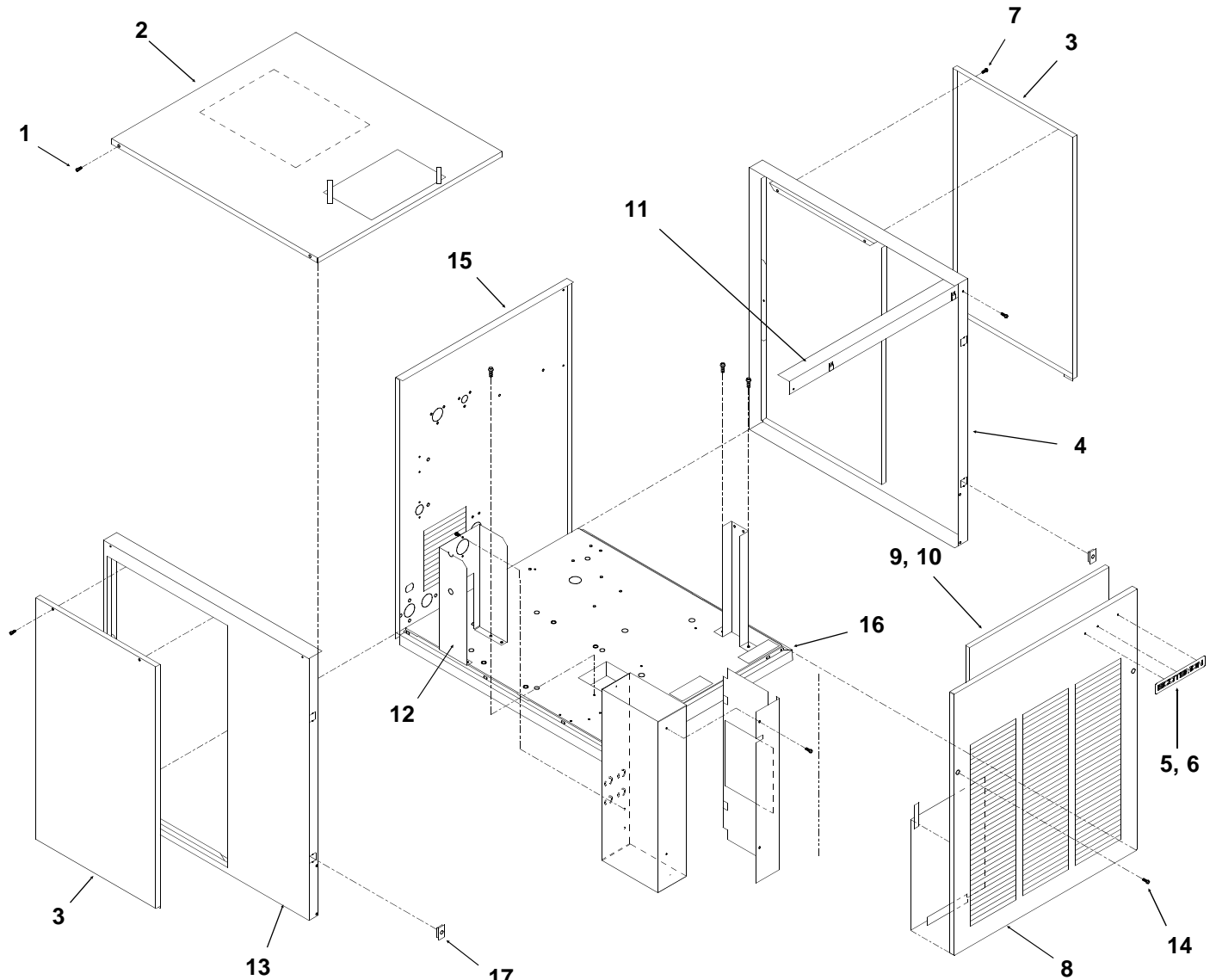

ITEM NUMBER	PART NUMBER	DESCRIPTION	ITEM NUMBER	PART NUMBER	DESCRIPTION
1	03-1531-01	Screw	9	02-2976-01	Filter Assembly
2	A33256-001	Top Panel, sandalwood	10	03-1660-01	Filter clip
	A33256-015	Top panel, gray	11	A34348-001	Ft. brace
	A33256-002	Top Panel, S.S.	12	A34039-001	Control Box Support
3	A34038-001	Service Panel, sandalwood	13	A32435-001	Left Side Panel, sandalwood
	A34038-015	Service panel, gray		A32435-015	Left side panel, gray
	A34038-002	Service Panel, S.S.		A32435-002	Left Side Panel, S.S.
4	A33292-001	Right Side Panel, s-wood	14	03-1419-22	Screw
	A33292-015	Right side panel, gray	15	Water Cooled only:	
	A33292-002	Right Side Panel, S.S.		A35924-001	Rear Panel, Painted
5	03-0271-00	Speed Clip		A35924-002	Rear panel, stainless
6	15-0711-01	Emblem, sandalwood		A35924-015	Rear panel, gray
	15-0808-03	Emblem, grey	16.	A35890-001	Base
7	03-1404-12	Screw	17	02-0836-00	Catch
8	A33255-001	Front Panel, sandalwood		15-0411-00	Strike (on front panel)
	A33255-015	Front panel, gray			
	A33255-002	Front Panel, S.S.			

NME950 & FME1200 SERVICE PARTS

Air Cooled Refrigeration

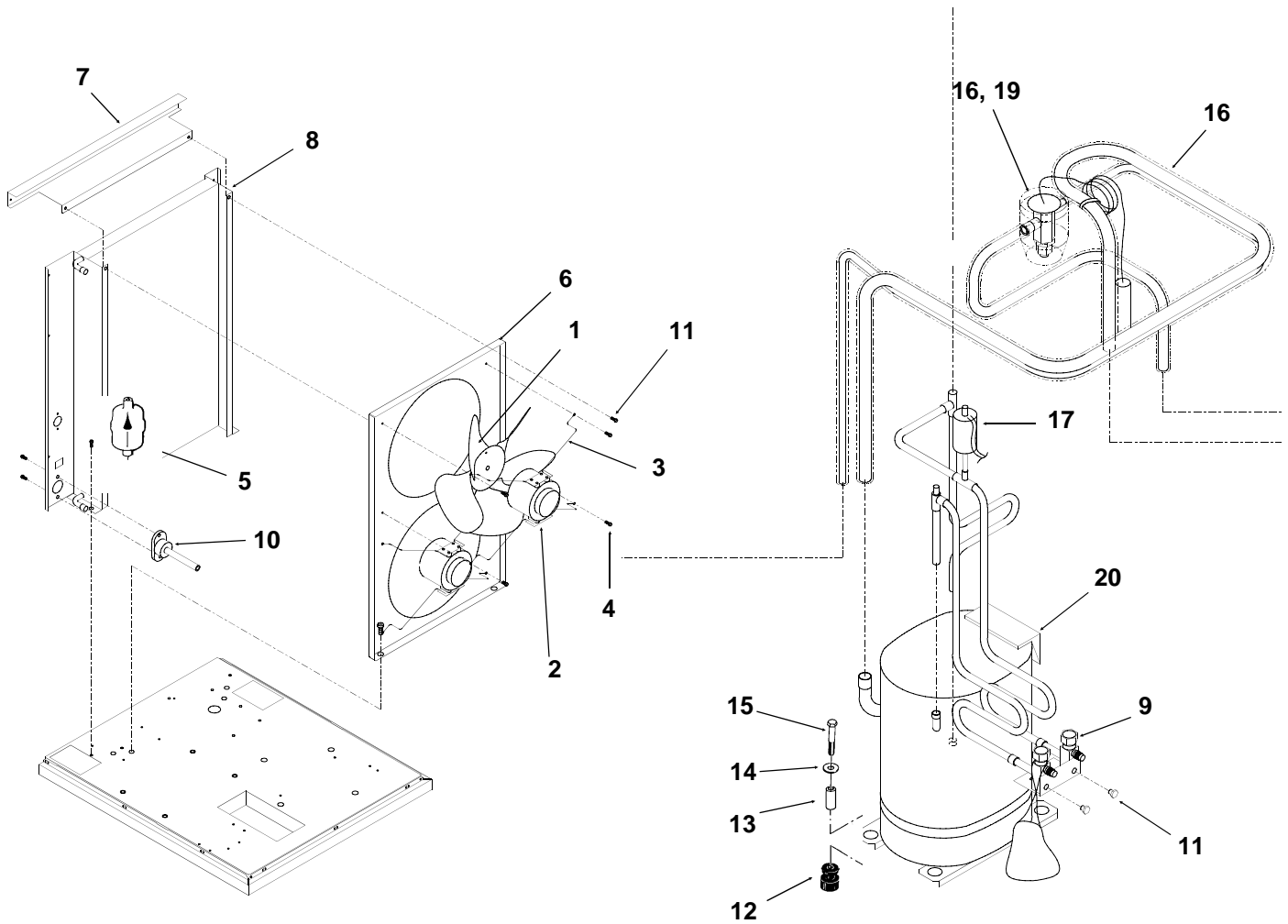

PART NUMBER	PART NUMBER	DESCRIPTION	ITEM NUMBER	PART NUMBER	DESCRIPTION
1	18-3815-01	Fan Blade	14	03-1407-07	Washer
2	12-1576-02	Fan Motor	15	03-1405-20	Cap Screw
3	02-2378-01	Fan Bracket	16	A36496-001	Suction Line
4	03-1404-12	Screw	17	11-0485-21	Hi Pressure Cut Out
5	02-3319-02	Dryer	18	A32961-020	Insulation Kit (3 piece)
6	A33231-001	Fan Shroud	19	11-0488-21	Thermo Expansion Valve
7	A35582-001	Fan shroud cover, painted	20	18-8768-22	Compressor 208-230/60/1
	A35582-002	Fan shroud cover, stainless			Overload for above is internal
8	18-8717-01	Condenser		18-8768-24	Compressor 200-230/60/3
9	16-0832-20	Access valve			Overload for above is internal
9a	16-0832-02	Stem cap		18-8772-26	Compressor 220-240/50/1
9b	16-0832-03	Core cap		18-8772-21	Overload for above
10	A34045-001	Drain casting			
11	03-1645-01	Screw			
12	18-2200-28	Grommet			
13	18-2300-27	Sleeve			

NME950-6B or FME1200-6B:		
21	11-0512-01	Low pressure cut out switch

NME950 & FME1200 SERVICE PARTS

Water Cooled Refrigeration

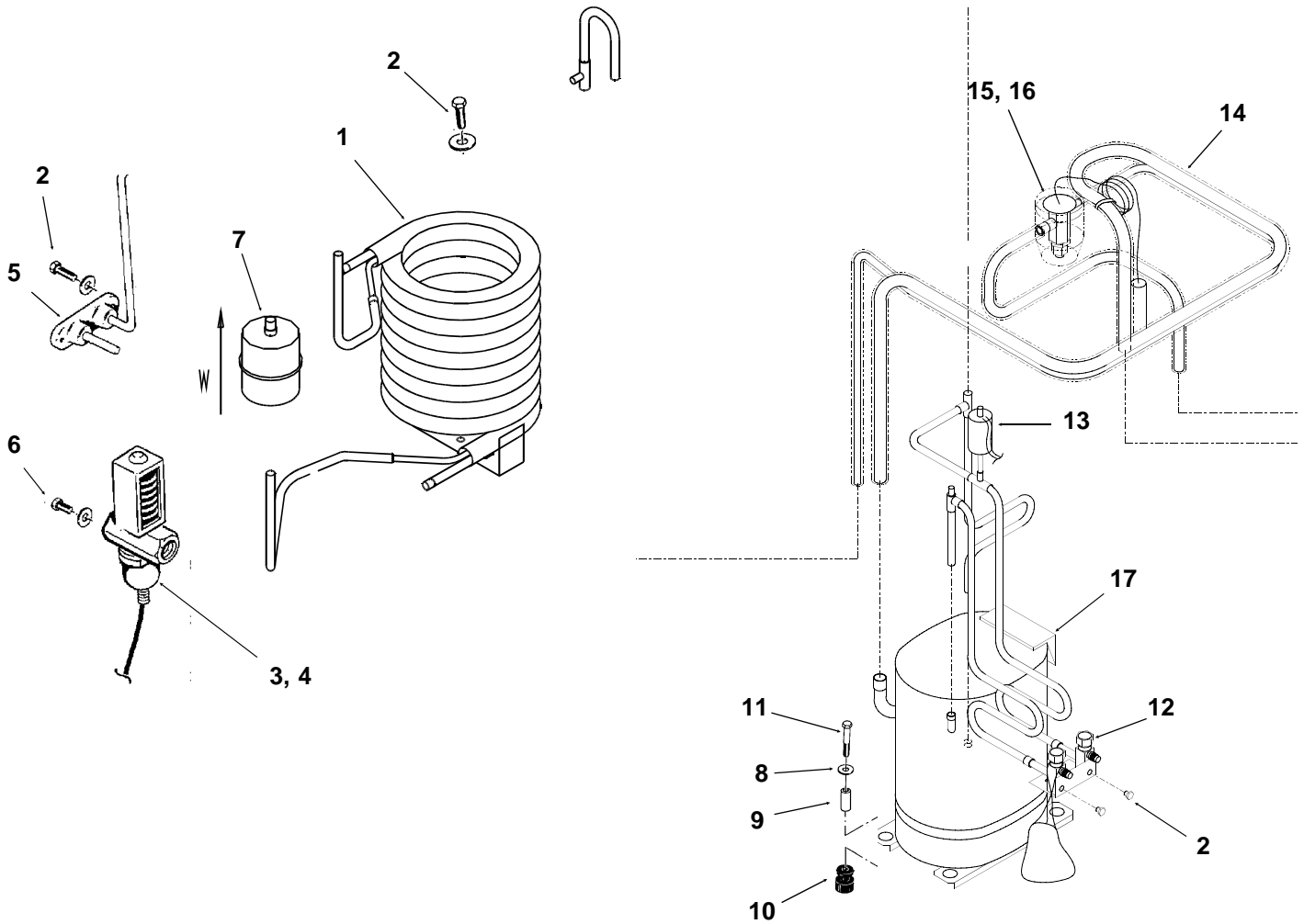

ITEM NUMBER	PART NUMBER	DESCRIPTION	ITEM NUMBER	PART NUMBER	DESCRIPTION
1	18-8718-21	Condenser	12	16-0832-20	Access Valve Complete
2	03-1645-01	Screw	12a	16-0832-02	Stem cap
3	11-0478-21	Water Reg. Valve	12b	16-0832-03	Core cap
4	16-0401-02	Elbow (not shown)	13	11-0485-21	Hi Pressure Cut Out
5	A34044-001	Drain Assembly	14	A36496-001	Suction Line
6	03-1403-14	Screw	15	A32961-020	Insulation Kit (3 piece)
7	02-3319-02	Dryer	16	11-0488-21	Thermo Expansion Valve
8	03-1407-07	Washer	17	18-8768-22	Compressor 208-230/60/1
9	18-2200-27	Sleeve			Overload for above is internal
10	18-2200-28	Grommet			18-8768-24 Compressor 200-230/60/3
11	03-1405-20	Screw			Overload for above is internal
					18-8772-26 Compressor 220-240/50/1
					18-8772-21 Overload for above
NME950-6B or FME1200-6B:					
			18	11-0512-01	Low pressure cut out switch

NME950 & FME1200 SERVICE PARTS

Water System

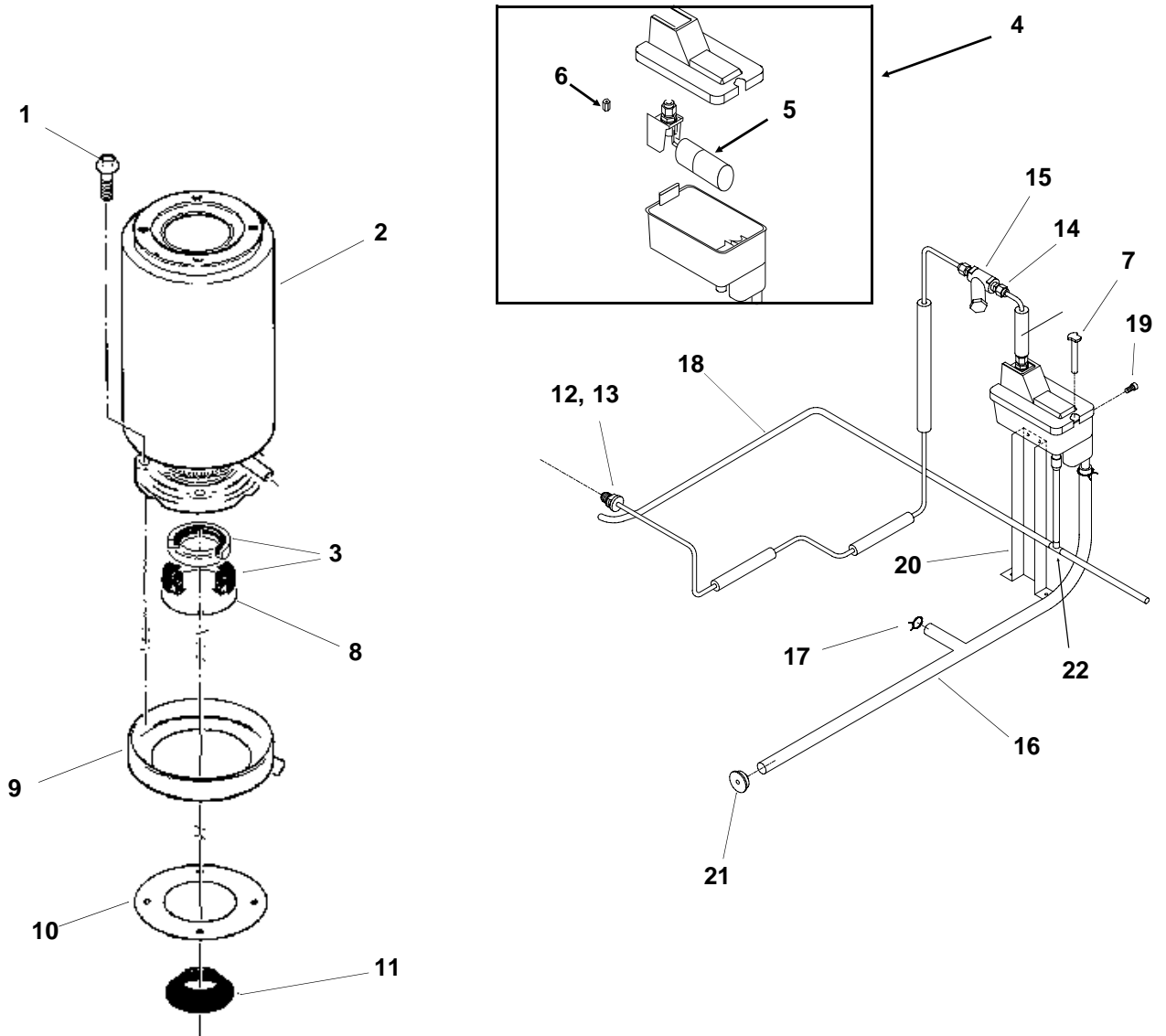

ITEM NUMBER	PART NUMBER	DESCRIPTION	ITEM NUMBER	PART NUMBER	DESCRIPTION
1	03-1420-03	Cap Screw	15	16-0162-00	Strainer
2	A32890-020	Evaporator	16	A36154-001	Evap. water inlet tube
3	02-0929-23	Water Seal	17	02-1338-00	Hose clamp
4	02-3266-20	Reservoir & valve	18	13-0079-03	Res. overflow hose
5	02-3266-21	Float valve	19	03-1639-03	Screw
6	02-3266-22	Plunger/seat	20	A36078-002	Reservoir bracket
7	A33101-022	Water Level Sensor	21	13-0840-01	Rubber cap
8	A32777-021	Retaining Ring for Seal	22	16-0670-02	Tee
9	A32050-001	Drip Pan			
10	13-0704-00	Gasket			
11	13-0868-01	Water Shed			
12	A27318-001	Water Inlet Fitting			
13	03-1394-01	Pal Nut			
14	16-0791-01	Coupling union			

NME950 & FME1200 SERVICE PARTS

Gearmotor

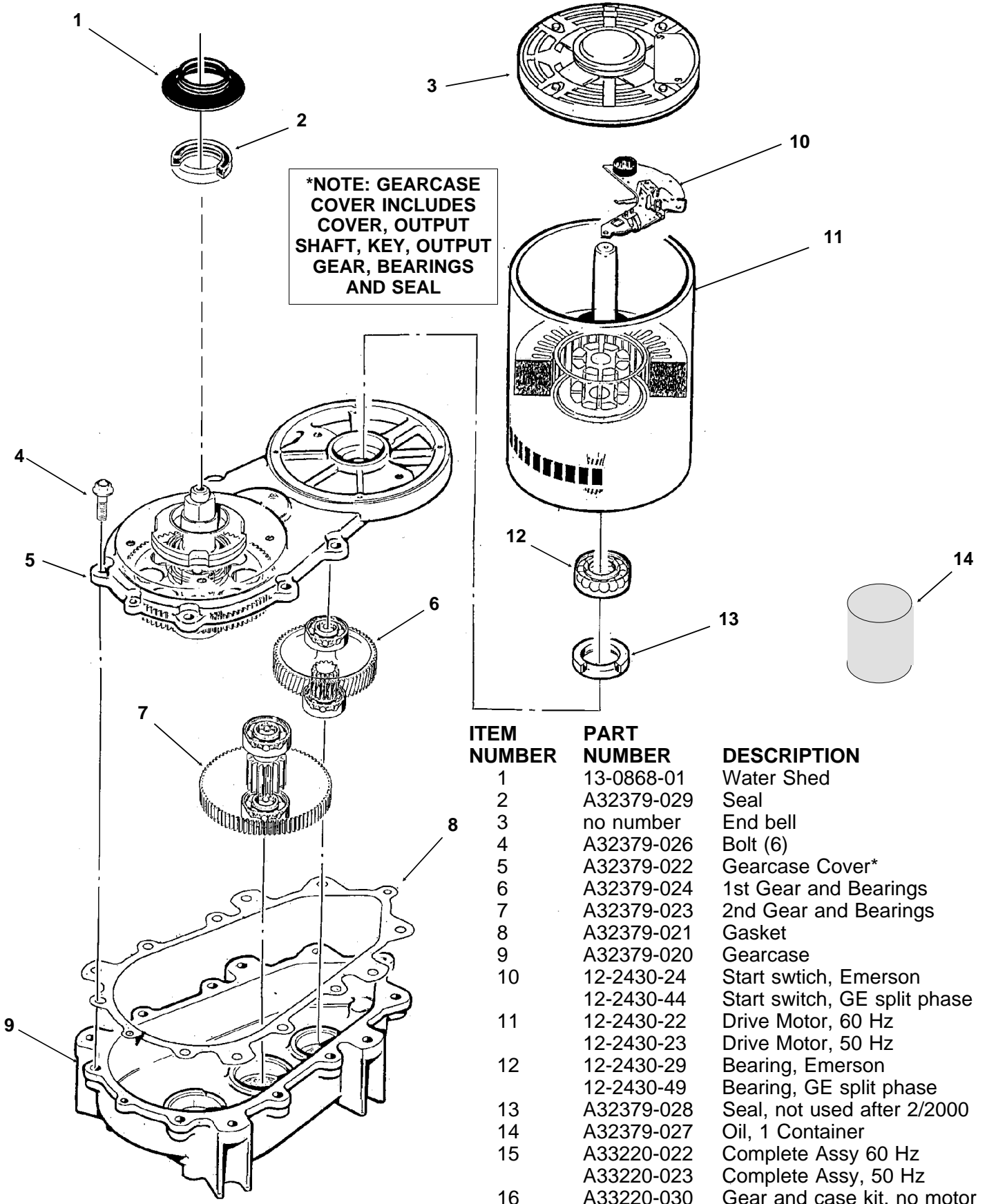

***NOTE: GEARCASE COVER INCLUDES COVER, OUTPUT SHAFT, KEY, OUTPUT GEAR, BEARINGS AND SEAL**

ITEM NUMBER	PART NUMBER	DESCRIPTION
1	13-0868-01	Water Shed
2	A32379-029	Seal
3	no number	End bell
4	A32379-026	Bolt (6)
5	A32379-022	Gearcase Cover*
6	A32379-024	1st Gear and Bearings
7	A32379-023	2nd Gear and Bearings
8	A32379-021	Gasket
9	A32379-020	Gearcase
10	12-2430-24	Start swtich, Emerson
	12-2430-44	Start switch, GE split phase
11	12-2430-22	Drive Motor, 60 Hz
	12-2430-23	Drive Motor, 50 Hz
12	12-2430-29	Bearing, Emerson
	12-2430-49	Bearing, GE split phase
13	A32379-028	Seal, not used after 2/2000
14	A32379-027	Oil, 1 Container
15	A33220-022	Complete Assy 60 Hz
	A33220-023	Complete Assy, 50 Hz
16	A33220-030	Gear and case kit, no motor

NME950 & FME1200 SERVICE PARTS

NME Evaporator

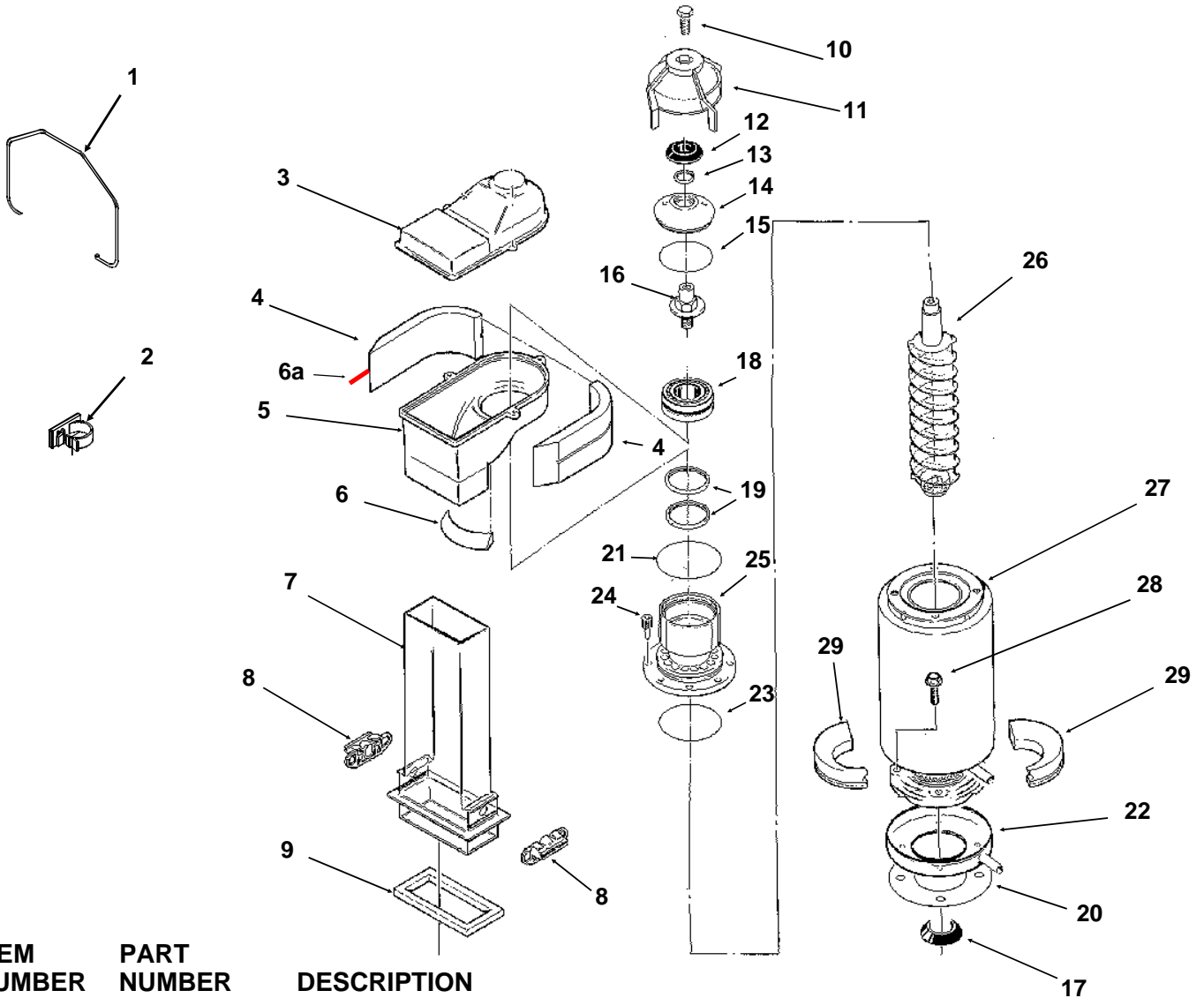

ITEM NUMBER	PART NUMBER	DESCRIPTION
1.	A34969-001	Bail clip
2.	02-3268-01	Drain tube holder
3.	02-2930-04	Ice Chute Cover
4.	A32963-001	Insulation Top (half)
5.	02-2926-01	Ice Chute Body
6.	A33102-001	Insulation Collar Inside
6a	A35419-020	Strap kit
7.	02-2929-04	Ice Chute Lower
8.	A37708-021	Bin Controls Assy. (set of 2)
9.	A32930-001	Chute Gasket
10.	03-1405-52	Hex Cap Screw
11.	02-3001-01	Ice Sweep
12.	13-0871-01	Water Shed
13.	02-2978-01	Lip Seal
14.	02-3128-20	Breaker Cover
15.	13-0617-52	O-Ring
16.	08-0660-01	Auger Stud & washer
17.	13-0868-01	Water Shed
18.	A34559-020	Bearing
19.	02-2977-01	Lip Seal
20.	13-0704-00	Drip Pan Gasket
21.	13-0617-54	O-Ring
22.	02-3837-01	Drip Pan
23.	13-0617-45	O-Ring
24.	03-1544-08	Soc. Head Screw
25.	A32900-020	Breaker (includes 18 & 19)
26.	A38071-022	Auger
27.	A32890-020	Evaporator
28.	03-1405-41	Cap Screw
29.	A32962-001	Insulation Bot. (half)

NME950 & FME1200 SERVICE PARTS

FME Evaporator

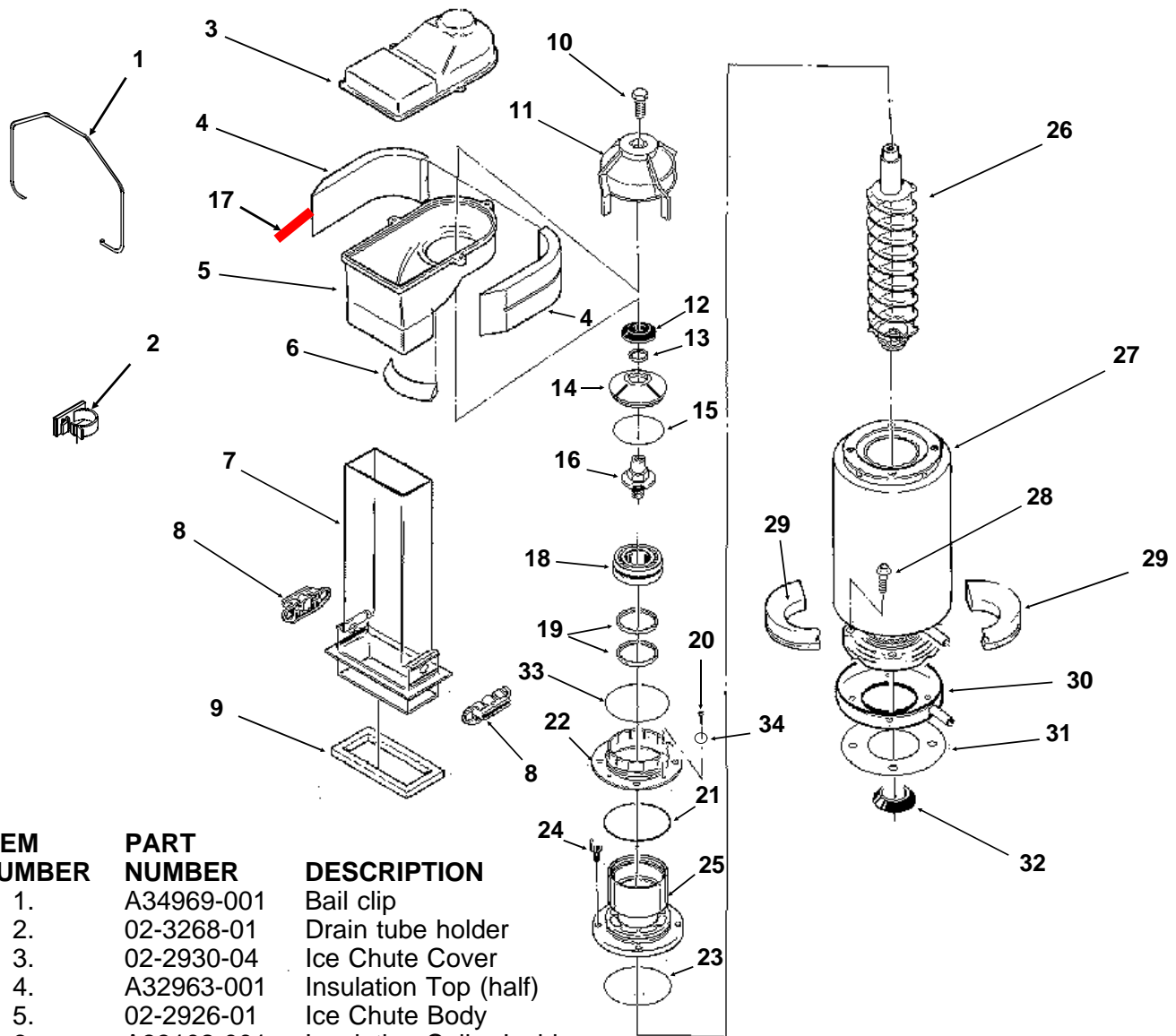

ITEM NUMBER	PART NUMBER	DESCRIPTION
1.	A34969-001	Bail clip
2.	02-3268-01	Drain tube holder
3.	02-2930-04	Ice Chute Cover
4.	A32963-001	Insulation Top (half)
5.	02-2926-01	Ice Chute Body
6.	A33102-001	Insulation Collar Inside
7.	02-2929-04	Ice Chute Lower
8.	A37708-021	Bin Controls Assy. (set of 2)
9.	A32930-001	Chute Gasket
10.	03-1405-52	Hex Cap Screw
11.	02-3001-01	Ice Sweep
12.	13-0871-01	Water Shed
13.	02-2978-01	Lip Seal
14.	02-3128-20	Breaker Cover
15.	13-0617-54	O-Ring
16.	08-0660-01	Auger Stud, thrust Washer
17.	A35419-020	Strap kit
18.	A34559-020	Bearing
19.	02-2977-01	Lip Seal
20.	03-1405-27	Screw
21.	13-0617-52	O-Ring
22.	02-2916-01	Slotted Collar
23.	13-0617-45	O-Ring
24.	03-1544-08	Soc. Head Screw
25.	A34505-020	Breaker (Divider) (includes 18 & 19)
26.	A38071-022	Auger
27.	A32890-020	Evaporator
28.	03-1405-41	Cap Screw
29.	A32962-001	Insulation Bot. (half)
30.	02-3837-01	Drip Pan
31.	13-0704-00	Drip Pan Gasket
32.	13-0868-01	Water Shed
33.	13-0617-49	O-Ring
34.	03-1408-36	Washer

NME950 & FME1200 SERVICE PARTS

Control Box

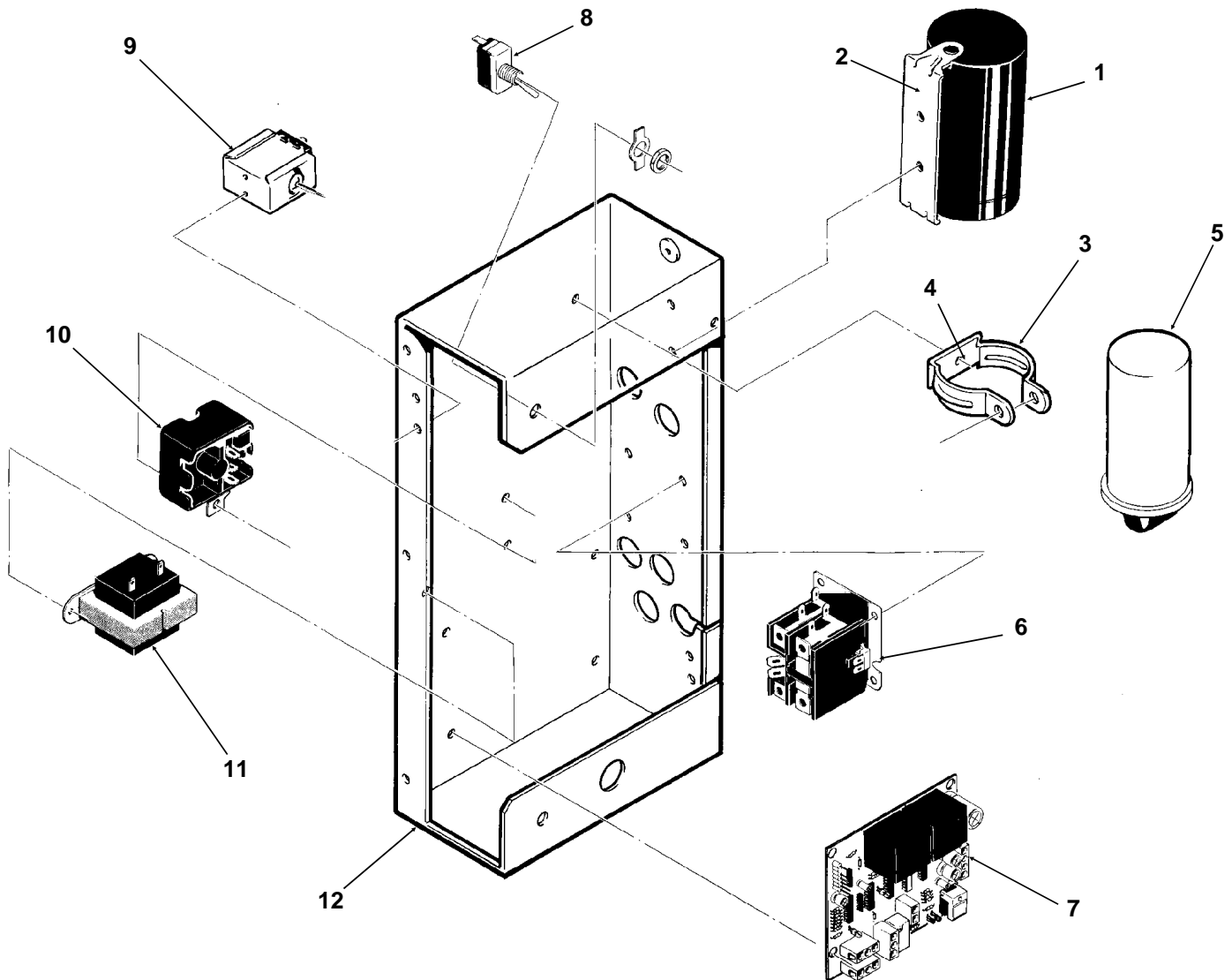

ITEM NUMBER	PART NUMBER	DESCRIPTION	ITEM NUMBER	PART NUMBER	DESCRIPTION
1	18-1901-54	Start Capacitor, 60 Hz	7	A37750-021	Circuit Board
	18-1901-53	Start Capacitor, 50 Hz	8.	12-0426-01	Master Switch
	18-4300-50	Start Capacitor Cap.	NME950-6B or FME1200-6B only:		
2.	18-2200-39	Start Capacitor Bracket		12-2637-01	Toggle Switch
	03-1638-04	Screw	9.	11-0447-20	Low Pressure Control
	03-1417-16	Lockwasher	10	18-1903-33	Potential Relay, 60 Hz
3.	A32872-001	Run Cap Bracket		18-1903-54	Potential relay, 50 Hz
	03-1652-02	Bolt	11.	12-2285-22	Transformer
	03-0255-04	Wing Nut	NME950-6B or FME1200-6B only:		
4.	03-1638-03	Screw		12-2639-01	Tranformer
5.	18-1902-45	Run capacitor, 60 Hz	12	no number	Control Box
	18-1902-53	Run capacitor, 50 Hz	NOT ILLUSTRATED		
6.	12-2469-02	Single Phase Contactor	13.	12-2340-01	4 Pin Plug Assy (Transformer to Circuit Board)
	12-0739-02	Three phase contactor	14.	A34055-001	Control Box Cover
			NME950-6B or FME1200-6B only:		
			15	12-2687-01	Fuse block
				12-2686-02	2A fuse

Note: Hz means Cycles, 50 Hz is 50 cycle, the model number ends in a -6 for 50 Hz models.

NME950 & FME1200 SERVICE PARTS

AIR AND WATER COOLED, 208-230/60/1

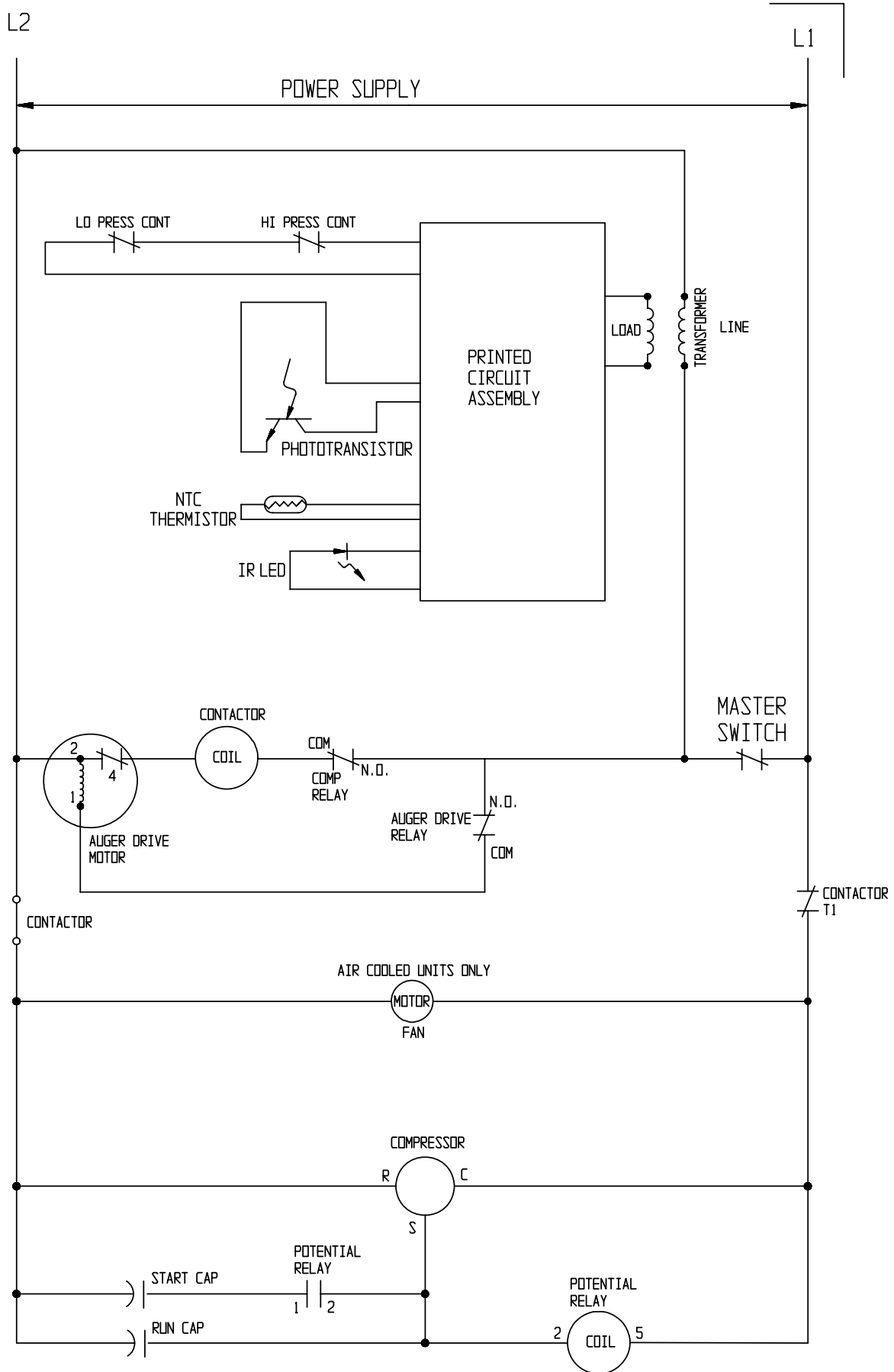

NME950 & FME1200 SERVICE PARTS

AIR AND WATER COOLED, 208-230/60/1

A36505-032

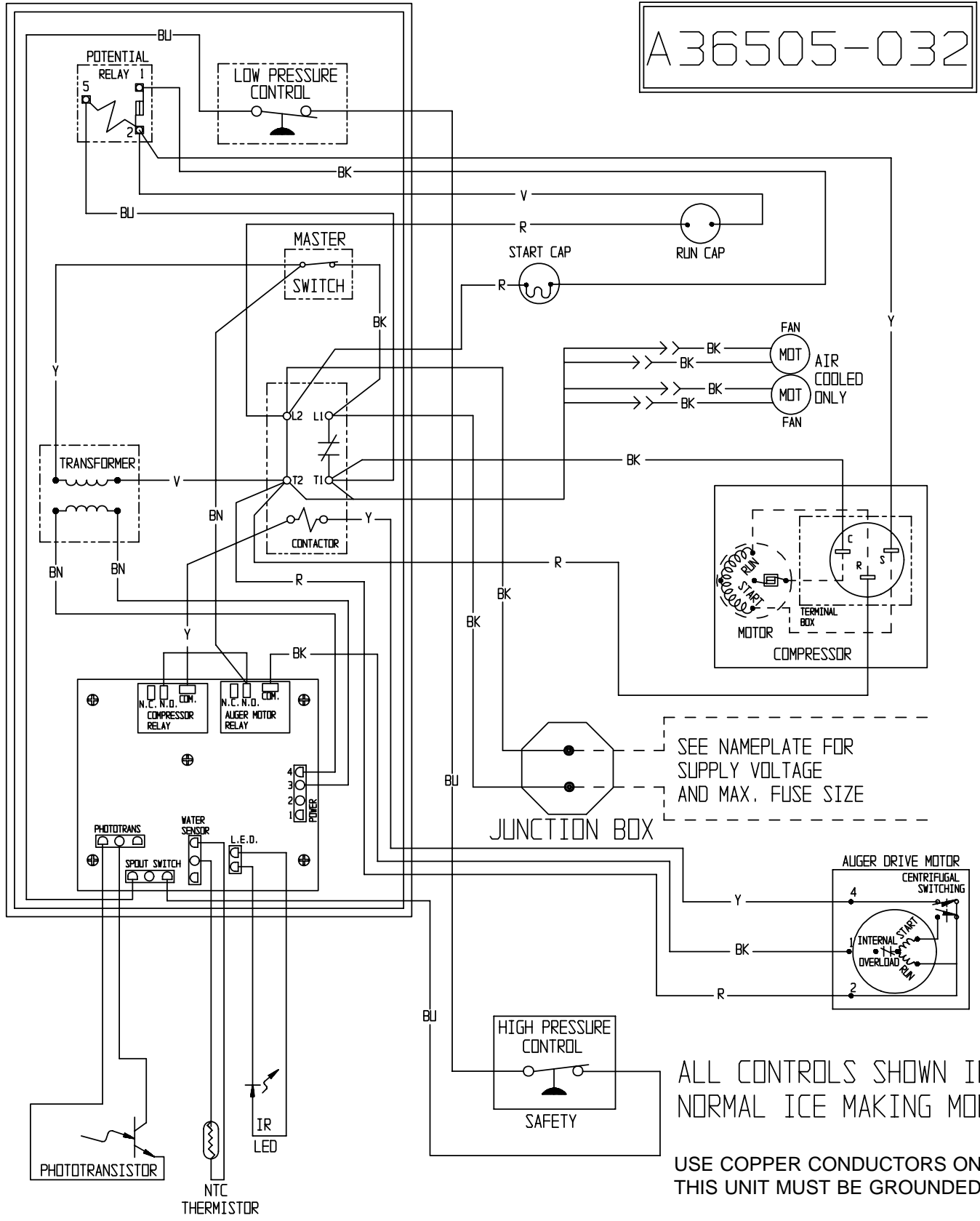

SEE NAMEPLATE FOR
SUPPLY VOLTAGE
AND MAX. FUSE SIZE

ALL CONTROLS SHOWN IN
NORMAL ICE MAKING MODE

USE COPPER CONDUCTORS ONLY
THIS UNIT MUST BE GROUNDED

NME950 & FME1200 SERVICE PARTS

AIR AND WATER COOLED, 208-230/60/3

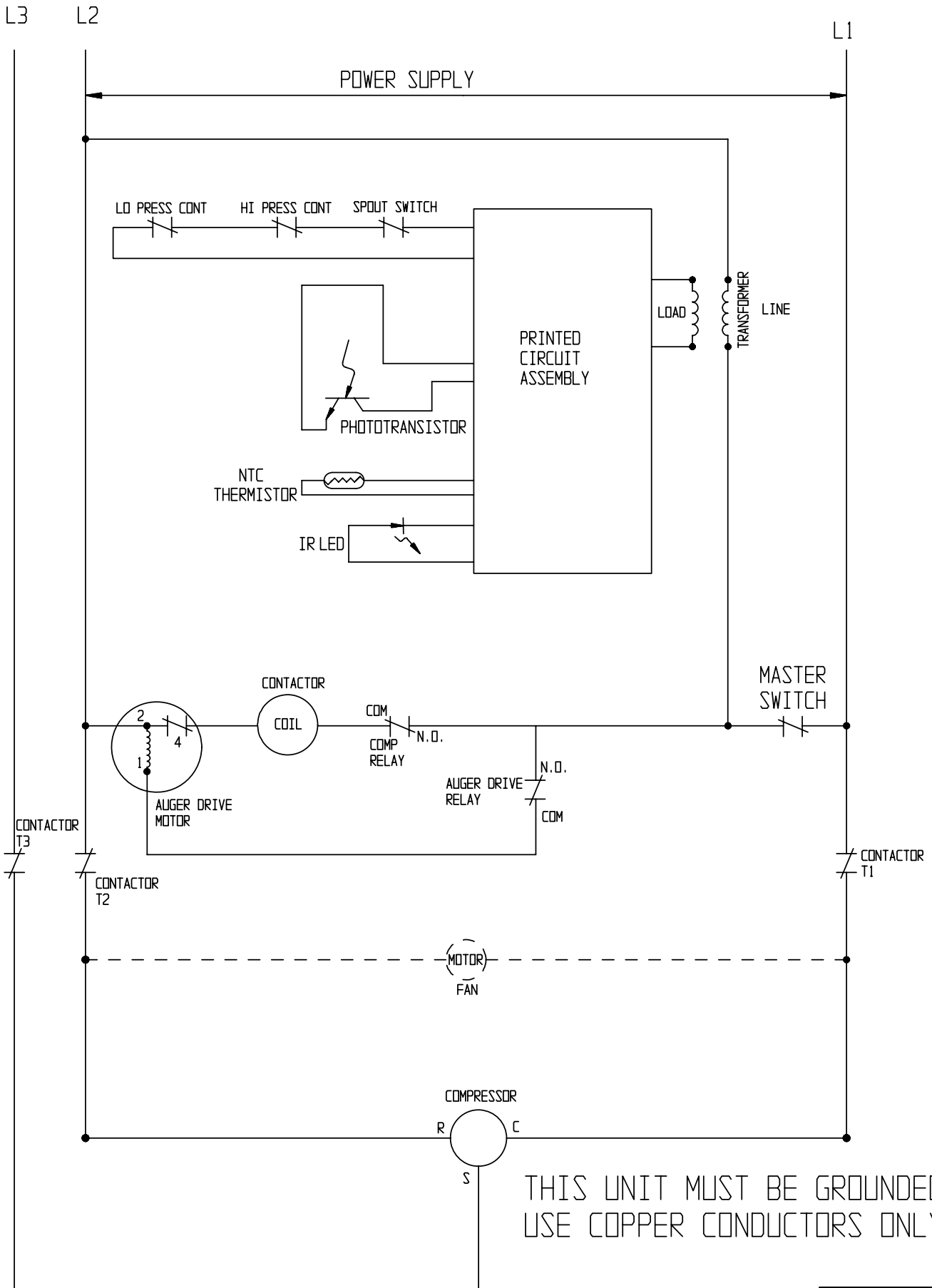

THIS UNIT MUST BE GROUNDED
USE COPPER CONDUCTORS ONLY

NME950 & FME1200 SERVICE PARTS

AIR AND WATER COOLED, 208-230/60/3

A36505-003

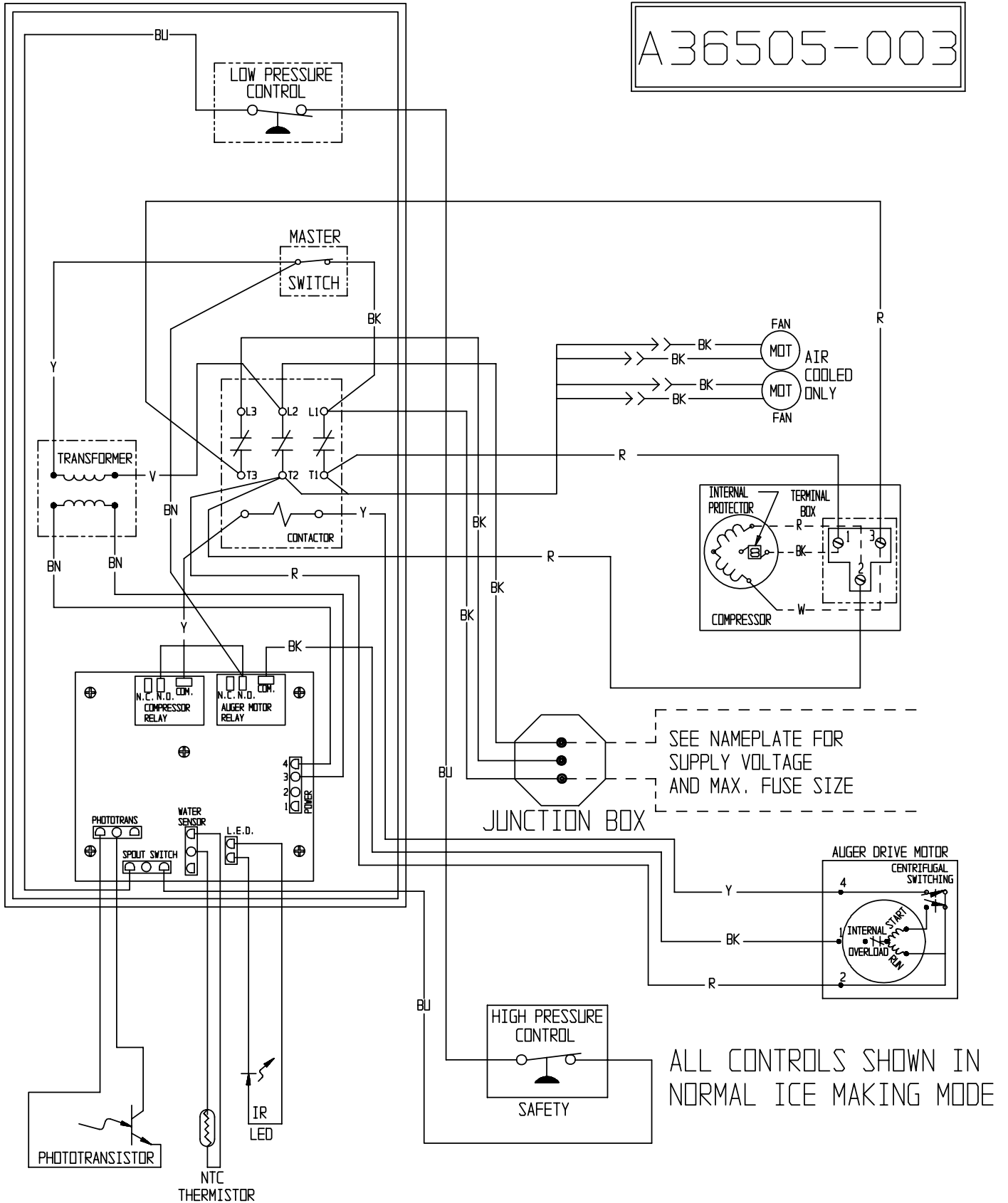

NME950 & FME1200 SERVICE PARTS

NME950 or FME1200 -6B

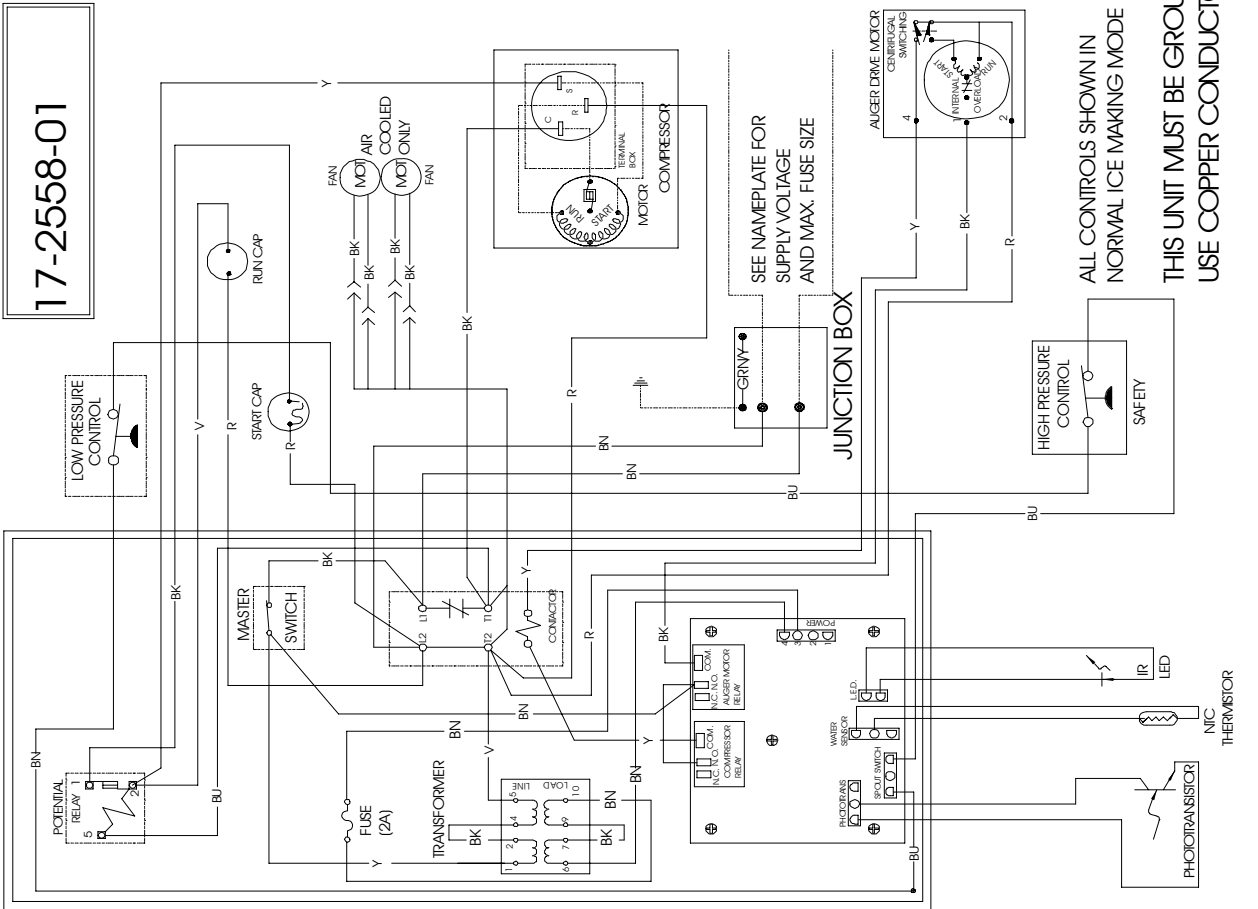
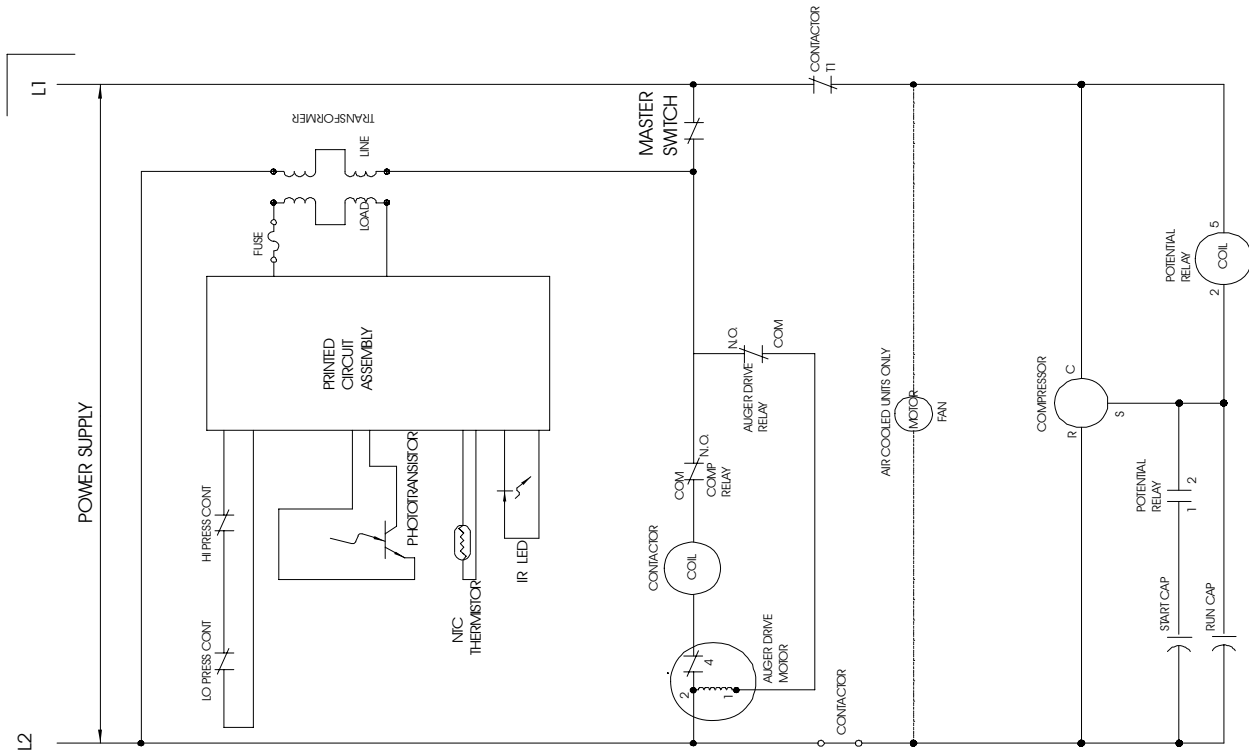

17-2558-01

SEE NAMEPLATE FOR
SUPPLY VOLTAGE
AND MAX. FUSE SIZE

JUNCTION BOX

ALL CONTROLS SHOWN IN
NORMAL ICE MAKING MODE

THIS UNIT MUST BE GROUNDED
USE COPPER CONDUCTORS ONLY